

规格书编号

SPEC NO : **HDDDB08NSBP4SP02**

# 产品规格书

# SPECIFICATION

CUSTOMER 客户: \_\_\_\_\_

PRODUCT 产品: \_\_\_\_\_ **SAW DUPLEXER** \_\_\_\_\_

MODEL NO 型号: \_\_\_\_\_ **HDDDB08NSB-P4** \_\_\_\_\_

MARKING 印字: \_\_\_\_\_ **HD C017** \_\_\_\_\_

PREPARED 编制: \_\_\_\_\_ **CHECKED 审核:** \_\_\_\_\_

APPROVED 批准: \_\_\_\_\_ **DATE 日期:** 2016-09-01

客户确认 CUSTOMER RECEIVED:		
审核 CHECKED	批准 APPROVED	日期 DATE

**无锡市好达电子有限公司**  
**Shoulder Electronics Limited**

Factory Address: NO. 115, Gaoyun Road, Binhu Economic & Technology Development Area, Wuxi, Jiangsu, China. Tel: 86-510-85629111  
Country of origin: China



### 1. Application

- Low-loss Saw duplexer for mobile telephone LTE and WCDMA Band8 systems
- Low insertion attenuation and low passband ripple.
- Usable passband 35MHz
- High isolation between Tx and Rx.
- Single ended to balanced transformation in Antenna - Rx path
- RoHS compatible

### 2. DIMENSION (PKG SIZE 2.0 x 1.6 x 0.6mm)

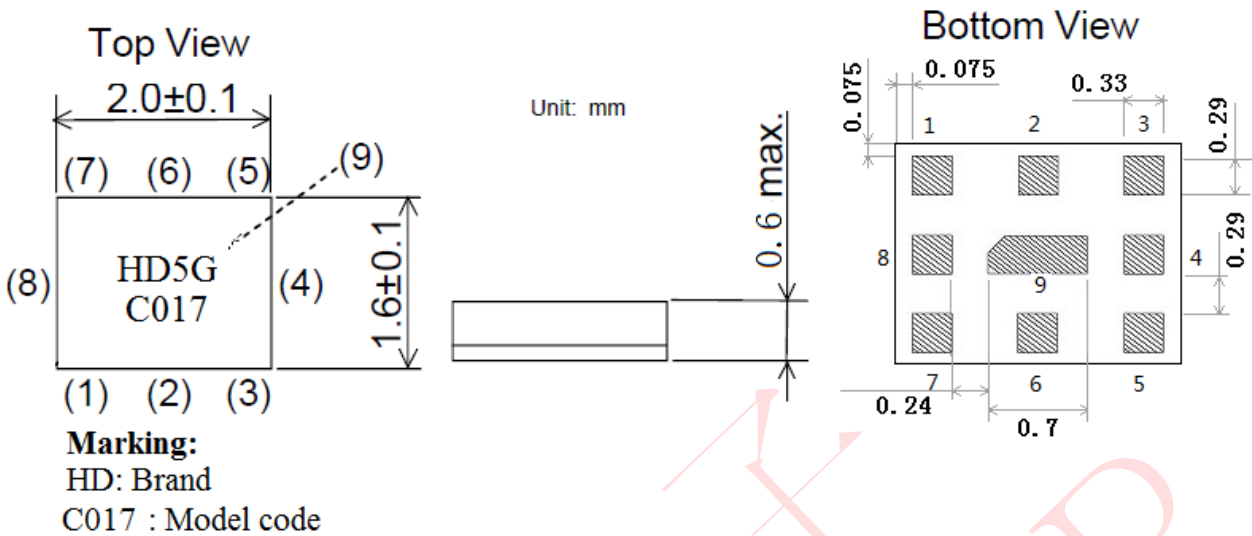

### 3. Pin Configuration

Pin No.	Pin name	Description
1	Rx	Receiver Pin (balanced)
2	GND	Ground Pin
3	Tx	Transmitter Pin
4	GND	Ground Pin
5	GND	Ground Pin
6	ANT	Antenna Pin
7	GND	Ground Pin
8	Rx	Receiver Pin (balanced)
9	GND	Ground Pin

### 4. Maximum Rating

Items	Conditions
Operation temperature rang	-30°C ~ +85°C
Storage temperature rang	-40°C ~ +85°C
ESD voltage	ESD(MM) : 50VDC
Sensitive discharge device	ESD(HBM) : 175VDC
DC Voltage VDC	3V (25+/-2 deg.C)
Moisture Sensitivity Level	MSL 2

**5. TEST CIRCUIT**

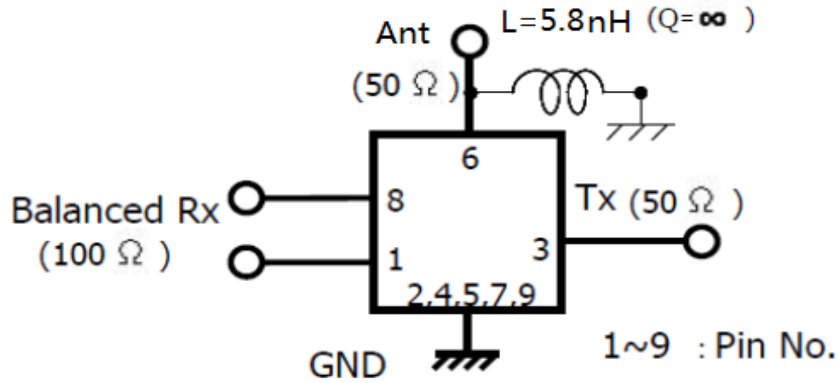

**6. ELECTRICAL SPECIFICATION**

**Table1. Electrical Specification**

Item		Condition (MHz)	Specification			Unit	
			Min	Typ	Max		
TX to ANT	Insertion loss	882.4~912.6	-	1.9	2.8	dB	
		880.4~914.6	-	2.4	3.5	dB	
	Pass band ripple	882.4~912.6	-	1.2	2.0	dB	
		VSWR	882.4~912.6	ANT	-	1.6	2.0
	Tx			-	1.6	2.0	-
	Input Power	882.4~912.6	+29dBm Ta=+50°C 5000h,CW			-	
	Absolute attenuation	927.4~957.6	40	50	-	dB	
		1565~1606	38	45	-	dB	
		1670~1880	30	40	-	dB	
		2110~2500	30	35	-	dB	
2620~3520		20	27	-	dB		
ANT to RX	Insertion loss	927.4~957.6	-	2.2	2.8	dB	
		925.4~959.6	-	2.3	3.5	dB	
	Pass band ripple	927.4~957.6	-	1.0	2.2	dB	
		VSWR	927.4~957.6	ANT	-	1.6	2.1
	Rx			-	1.7	2.1	-
	Absolute attenuation	882.4~912.6	45	53	-	dB	
		980~1045	10	28	-	dB	
		1045~2880	40	50	-	dB	
3700~4800		35	45	-	dB		

**Table2. Electrical Specification**

Item		Condition (MHz)	Specification			Unit	Remarks
			Min	Typ	Max		
TX to RX	Isolation	882.4~912.6	52	58	-	dB	
		927.4~957.6	48	54	-	dB	
Terminating Impedance		Tx port	50			Ohm	Single-ended
		Rx port	100			Ohm	Differential
		Ant port	50//5.8nH			Ohm	Single-ended
Operating Temperature			-20 to +85			oC	

**7. Typical frequency response**

**Tx to Ant**

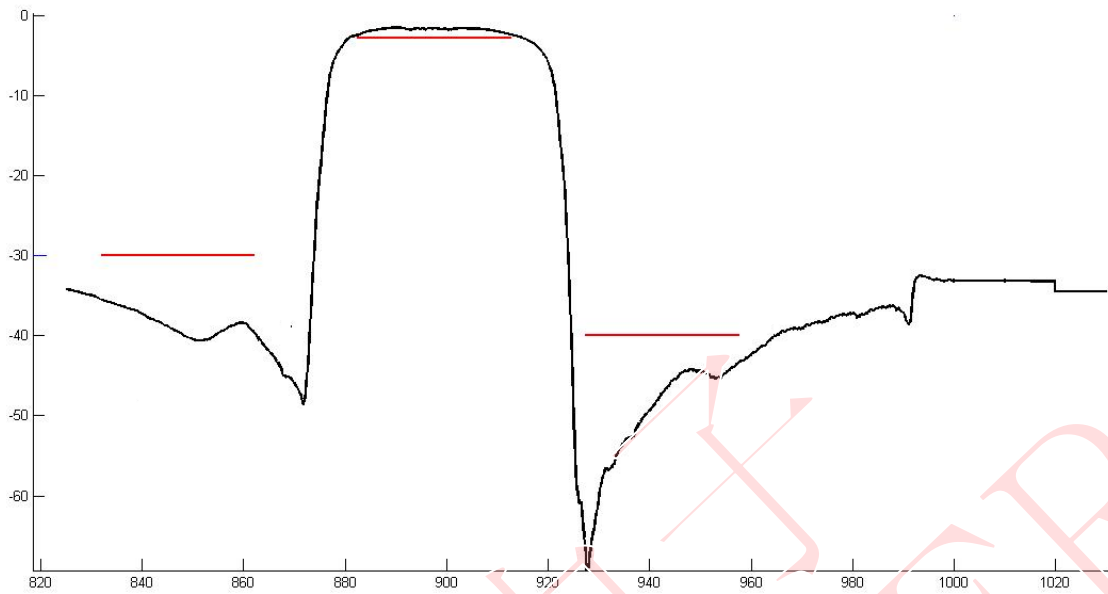

**Ant to Rx**

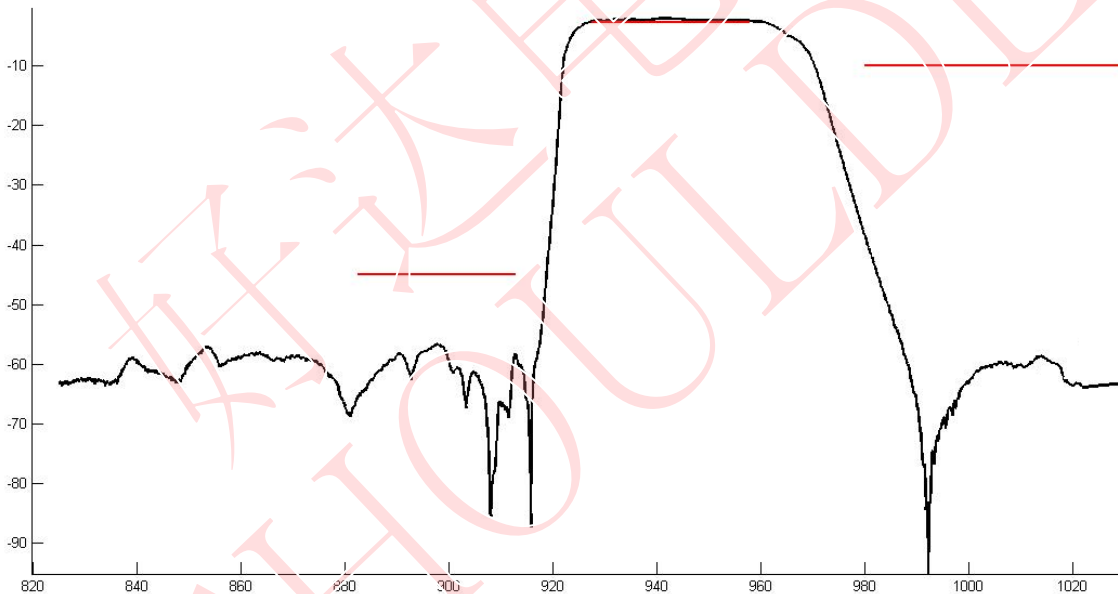

**Tx to Rx Isolation**

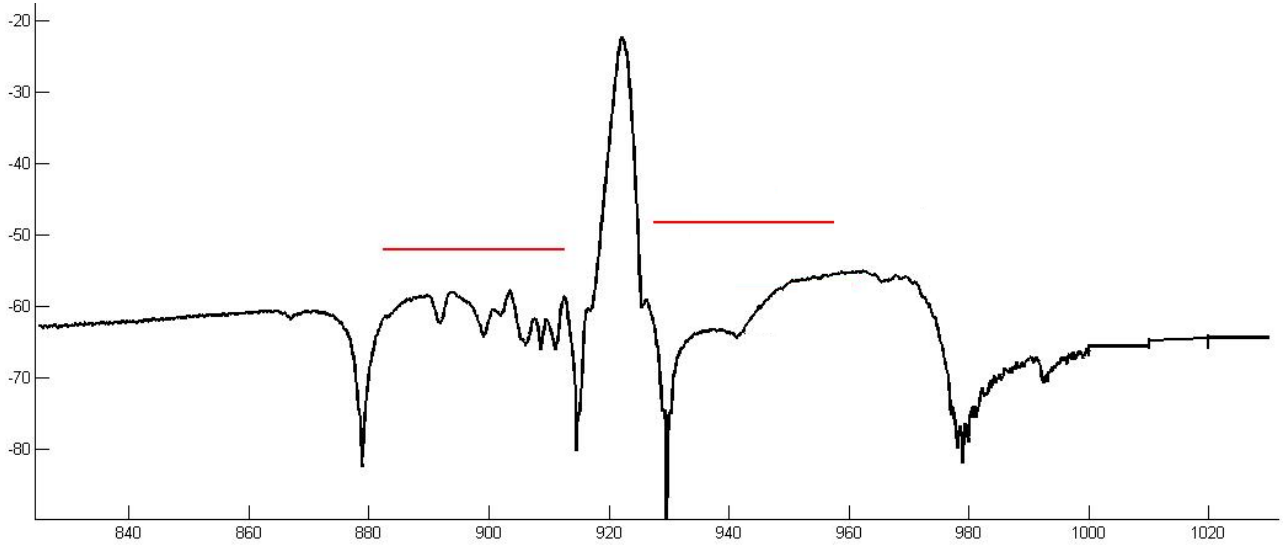

**8. ENVIRONMENTAL CHARACTERISTICS**

**8.1 High temperature exposure**

Subject the device to +85°C for 16 hours. Then release the filter into the room conditions for 24 hours prior to the measurement. It shall fulfill the specifications in 5.

**8.2 Low temperature exposure**

Subject the device to -40°C for 16 hours. Then release the device into the room conditions for 24 hours prior to the measurement. It shall fulfill the specifications in 5.

**8.3 Temperature cycling**

Subject the device to a low temperature of -40°C for 30 minutes. Following by a high temperature of +85°C for 30 Minutes. Then release the device into the room conditions for 24 hours prior to the measurement. It shall meet the specifications in 5.

**8.4 Resistance to solder heat**

- 1、immerge the solder bath at 260°C for 10 sec.
- 2、the iron at 370°C for 3 sec

**8.5 Solderability**

Subnerge the device terminals into the solder bath at 245°C ±5°C for 5s, More than 95% area of the soldering pad must be covered with new solder. It shall meet the specifications in 5.

**8.6 Reflow soldering**

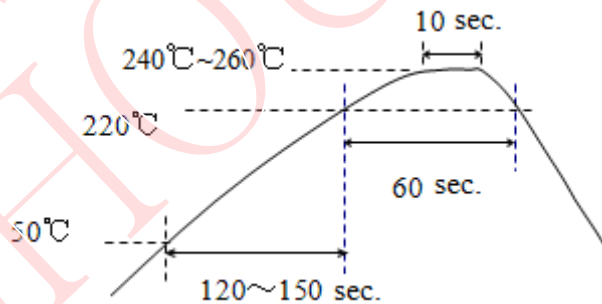

The specimen shall be passed through the reflow furnace with the condition shown in the above profile for 1 time.

The specimen shall be stored at standard atmospheric conditions for 1h, after which the measurement shall be made. Test board shall be 1.6 mm thick. Base material shall be glass fabric base epoxy resin.

#### 8.7 Mechanical shock

Drop the device randomly onto the concrete floor from the height of 1m 3 times. the device shall fulfill the specifications in 5.

#### 8.8 Vibration

Subject the device to the vibration for 1 hour each in x,y and z axes with the amplitude of 1.5 mm at 10 to 55 Hz. The device shall fulfill the specifications in 5.

## 9. REMARK

#### 9.1 Static voltage

Static voltage between signal load & ground may cause deterioration & destruction of the component. Please avoid static voltage.

#### 9.2 Ultrasonic cleaning

Ultrasonic vibration may cause deterioration & destruction of the component. Please avoid ultrasonic cleaning

#### 9.3 Soldering

Only pad component may be solded. Please avoid soldering another part of component.

## 10. Packing

#### 10.1 Dimensions

(1) Carrier Tape: Figure 1

(2) Reel: Figure 2

(3) The product shall be packed properly not to be damaged during transportation and storage.

#### 10.2 Reeling Quantity

10000 pcs/reel  $\phi$  257.5mm

#### 10.3 Taping Structure

(1) The tape shall be wound around the reel in the direction shown below.

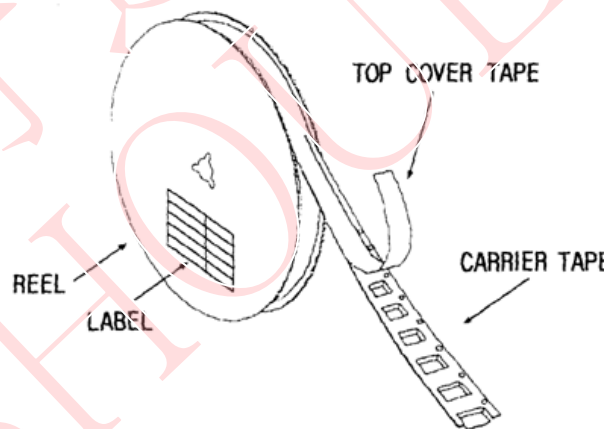

(2) Label

Device Name	
Marking	
User Product Name	
Quantity	
Lot No.	

(3) Leader part and vacant position specifications.

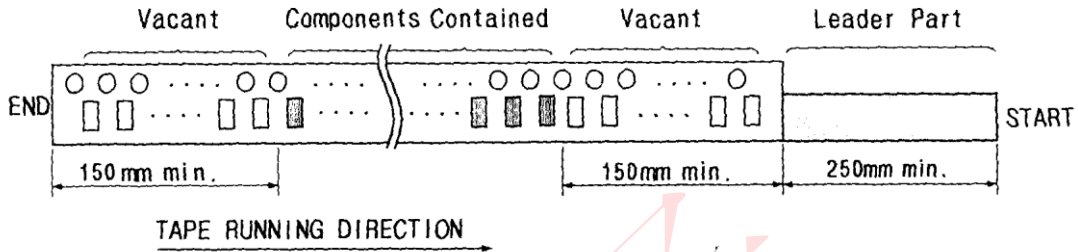

**11. TAPE SPECIFICATIONS**

11.1 Tensile Strength of Carrier Tape: 4.4N/mm width

11.2 Top Cover Tape Adhesion (See the below figure)

- (1) pull off angle: 0~15°
- (2) speed: 300mm/min.
- (3) force: 20~70g

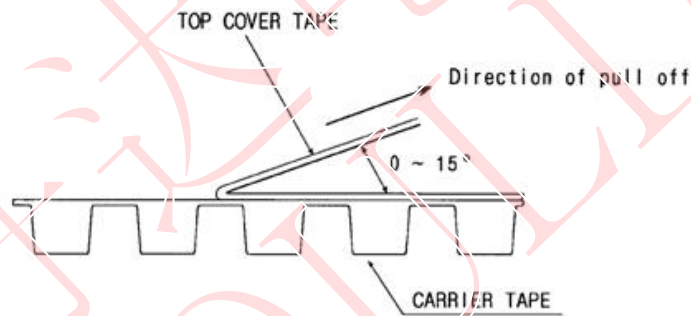

**[Figure 1] Carrier Tape Dimensions**

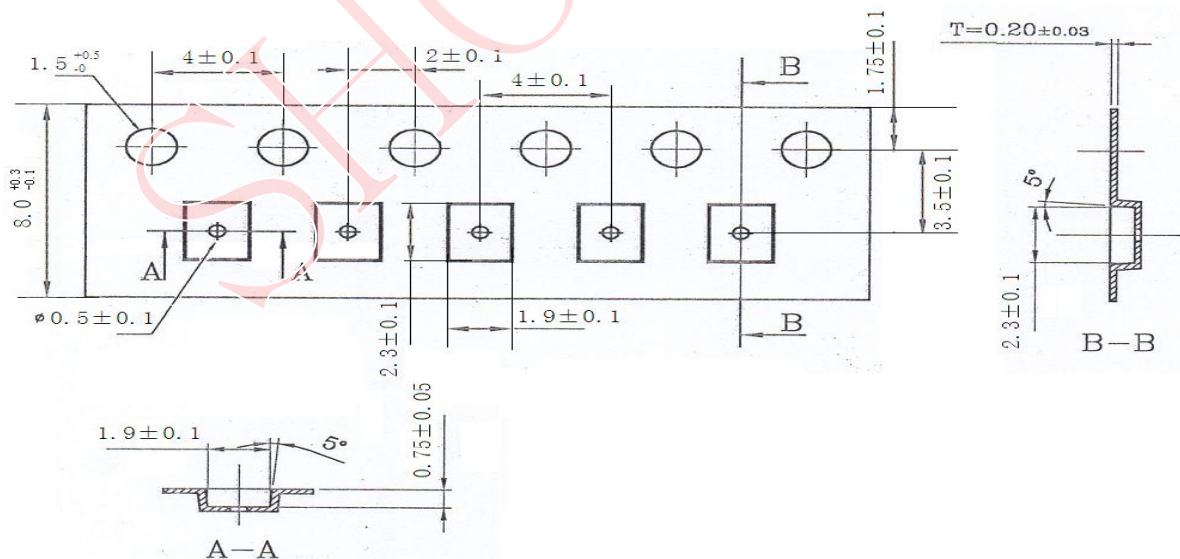



[Figure 2] 10000 pcs/reel  $\phi$  257.5mm

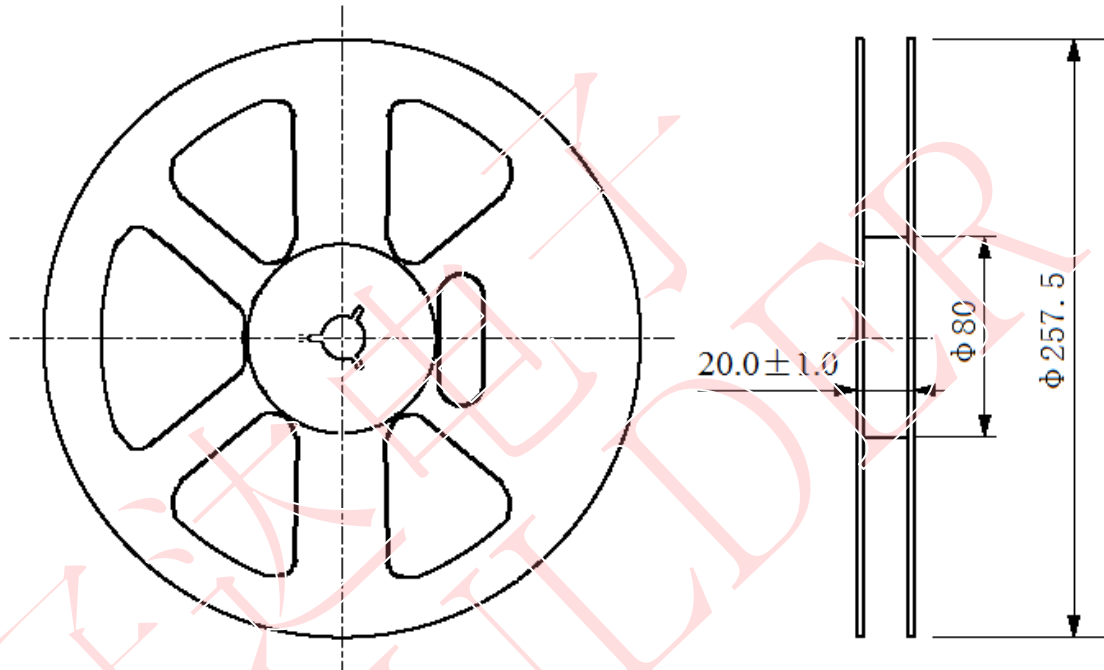

$\phi$  257.5 Reel Dimension

(in mm)

## X-ON Electronics

Largest Supplier of Electrical and Electronic Components

*Click to view similar products for [Signal Conditioning](#) category:*

*Click to view products by [SHOULDER Electronics](#) manufacturer:*

Other Similar products are found below :

[MAPDCC0004](#) [PD0409J5050S2HF](#) [880157](#) [HHS-109-PIN](#) [DC1417J5005AHF](#) [DC4859J5005AHF](#) [AFS14A30-2185.00-T3](#) [AFS14A35-1591.50-T3](#) [DS-323-PIN](#) [DSS-313-PIN](#) [B39321R801H210](#) [B39321R821H210](#) [B39921B4317P810](#) [1A0220-3](#) [2089-6207-00](#) [JP510S](#) [LFB212G45SG8C341](#) [LFB322G45SN1A504](#) [LFL182G45TC3B746](#) [SF2159E](#) [30057](#) [1P510S](#) [CER0813B](#) [3A325](#) [40287](#) [41180](#) [ATB3225-75032NCT](#) [B69842N5807A150](#) [BD0810N50100AHF](#) [BD2326L50200AHF](#) [BD2425J50200AHF](#) [HMC189AMS8TR](#) [C5060J5003AHF](#) [JHS-114-PIN](#) [JP503AS](#) [DC0710J5005AHF](#) [DC2327J5005AHF](#) [DC3338J5005AHF](#) [43020](#) [LFB2H2G60BB1C106](#) [LFL15869MTC1B787](#) [X3C19F1-20S](#) [XC3500P-20S](#) [10013-20](#) [SF2081E](#) [SF2194E](#) [SF2238E](#) [CDBLB455KCAX39-B0](#) [RF1353C](#) [PD0922J5050D2HF](#)