

N-沟道功率 MOS 管/ N-CHANNEL POWER MOSFET

SIF7N60F

- 特点: 热阻低 开关速度快 输入阻抗高 符合RoHS规范
- FEATURES: ■LOW THERMAL RESISTANCE ■FAST SWITCHING ■HIGH INPUT RESISTANCE
■RoHS COMPLIANT
- 应用: 电子镇流器 电子变压器 开关电源
- APPLICATION: ■ELECTRONIC BALLAST ■ELECTRONIC TRANSFORMER ■SWITCH MODE POWER SUPPLY

●最大额定值 (TC=25°C)

●Absolute Maximum Ratings (Tc=25°C)

TO-220/220FP(L)/262/263

参数 PARAMETER	符号 SYMBOL	额定值 VALUE	单位 UNIT
漏-源电压 Drain-source Voltage	V_{DS}	600	V
栅-源电压 gate-source Voltage	V_{GS}	±30	V
漏极电流 Continuous Drain Current TC=25°C	I_D	7.0	A
漏极电流 Continuous Drain Current TC=100°C	I_D	3.2	A
最大脉冲电流① Drain Current — Pulsed	I_{DM}	28	A
耗散功率 Power Dissipation	P_{tot}	TO-220:147	W
		TO-220FP:50	
		TO-262/263:147	
最高结温 Junction Temperature	T_J	150	°C
存储温度 Storage Temperature	T_{STG}	-55-150	°C
单脉冲雪崩能量② Single Pulse Avalanche Energy	E_{AS}	440	mJ

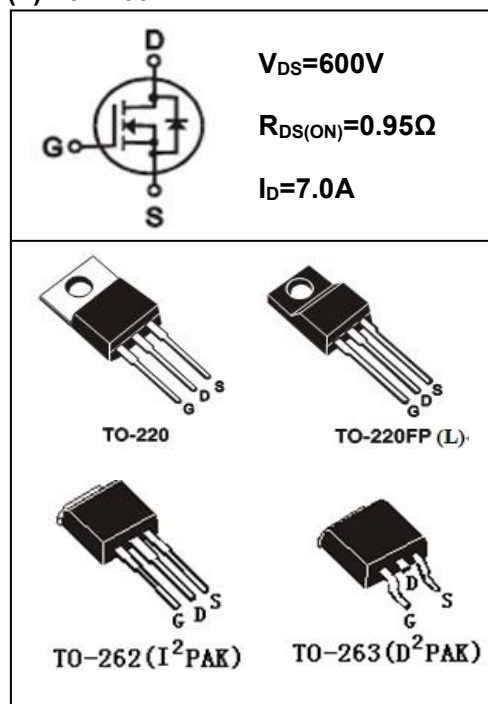

●电特性 (Tc=25°C)

●Electronic Characteristics (Tc=25°C)

参数 PARAMETER	符号 SYMBOL	测试条件 TEST CONDITION	最小值 MIN	典型值 TYP	最大值 MAX	单位 UNIT
漏-源击穿电压 Drain-source Breakdown Voltage	BV_{DSS}	$V_{GS}=0V, I_D=250\mu A$	600			V
击穿电压温度系数 Breakdown Voltage Temperature Coefficient	$\Delta BV_{DSS}/\Delta T_J$	$I_D=250\mu A$, Referenced to 25°C		0.65		V/°C
栅极开启电压 Gate Threshold Voltage	$V_{GS(TH)}$	$V_{GS}=V_{DS}, I_D=250\mu A$	2.0		4.0	V
漏-源漏电流 Drain-source Leakage Current	I_{DSS}	$V_{DS}=600V, V_{GS}=0V, T_J=25^\circ C$			1	μA
		$V_{DS}=480V, V_{GS}=0V, T_J=125^\circ C$			10	μA
跨导 Forward Transconductance	g_{fs}	$V_{DS}=15V, I_D=3.5A$ ③		5.0		S

●订单信息/ORDERING INFORMATION:

包装形式/PACKING	订货编码/ORDERING CODE	
	普通塑封料/ Normal Package Material	无卤塑封料/Halogen Free
TO-220 条管装/TUBE PACKING	SIF7N60F TO-220-TU	SIF7N60F TO-220-TU-HF
TO-220FP 条管装/TUBE PACKING	SIF7N60F TO-220FP-TU	SIF7N60F TO-220FP-TU-HF
TO-262 或 263 条管装/TUBE PACKING	SIF7N60F TO-262-TU 或 SIF7N60F TO-263-TU	SIF7N60F TO-262-TU-HF 或 SIF7N60F TO-263-TU-HF
TO-263 编带装/TAPE & REEL PACKING	SIF7N60F TO-263-TR	SIF7N60F TO-263-TR-HF

N-沟道功率 MOS 管/ N-CHANNEL POWER MOSFET

SIF7N60F

参数 PARAMETER	符号 SYMBOL	测试条件 TEST CONDITION	最小值 MIN	典型值 TYP	最大值 MAX	单位 UNIT
栅极漏电流 Gate-body Leakage Current ($V_{DS} = 0$)	I_{GSS}	$V_{GS} = \pm 30V$			± 100	nA
漏-源导通电阻 Static Drain-source On Resistance	$R_{DS(ON)}$	$V_{GS} = 10V, I_D = 3.5A$ ③		0.95	1.2	Ω
输入电容 Input Capacitance	C_{iss}	$V_{GS} = 0V, V_{DS} = 25V$ $F = 1.0MHz$		1050		pF
输出电容 Output Capacitance	C_{oss}			84		
反馈电容 Feedback Capacitance	C_{rss}			12		
关断延迟 Turn -Off Delay Time	$T_d(off)$	$V_{DD} = 300V, I_D = 7.0A$ $R_G = 25\Omega$ ③		50		ns
栅极电荷 Total Gate Charge	Q_g	$I_D = 7.0A, V_{DS} = 480V$ $V_{GS} = 10V$ ③		21		nC
栅源电荷 Gate-to-Source Charge	Q_{gs}			4.8		nC
栅漏电荷 Gate-to-Drain Charge	Q_{gd}			6.5		nC
二极管正向电流 Continuous Diode Forward Current	I_S				7.0	A
二极管正向压降 Diode Forward Voltage	V_{SD}	$T_j = 25^\circ C, I_S = 7.0A$ $V_{GS} = 0V$ ③			1.4	V
反向恢复时间 Reverse Recovery Time	t_{rr}	$T_j = 25^\circ C, I_f = 7.0A$ $di/dt = 100A/\mu s$ ③		365		ns
反向恢复电荷 Reverse Recovery Charge	Q_{rr}			3.4		μC

● 热特性

● Thermal Characteristics

参数 PARAMETER	符号 SYMBOL	最大值 MAX		单位 UNIT
		TO-220	TO-220FP	
热阻结-壳 Thermal Resistance Junction-case	R_{thJC}	0.85	2.50	$^\circ C/W$
热阻结-环境 Thermal Resistance Junction-ambient	R_{thJA}	62.5	62.5	$^\circ C/W$

注释(Notes):

① 脉冲宽度: 以最高节温为限制

Repetitive rating: Pulse width limited by maximum junction temperature

② 初始结温= $25^\circ C$, $V_{DD} = 50V$, $L = 18mH$, $R_G = 25\Omega$, $I_{AS} = 7.0A$

Starting $T_j = 25^\circ C$, $V_{DD} = 50V$, $L = 18mH$, $R_G = 25\Omega$, $I_{AS} = 7.0A$

③ 脉冲测试: 脉冲宽度 $\leq 300\mu s$, 占空比 $\leq 2\%$

Pulse Test : Pulse width $\leq 300\mu s$, Duty cycle $\leq 2\%$

N-沟道功率 MOS 管/ N-CHANNEL POWER MOSFET

SIF7N60F

● 特性曲线



图1 输出特性曲线, Tc=25°C

Fig1 Typical Output Characteristics, Tc=25°C

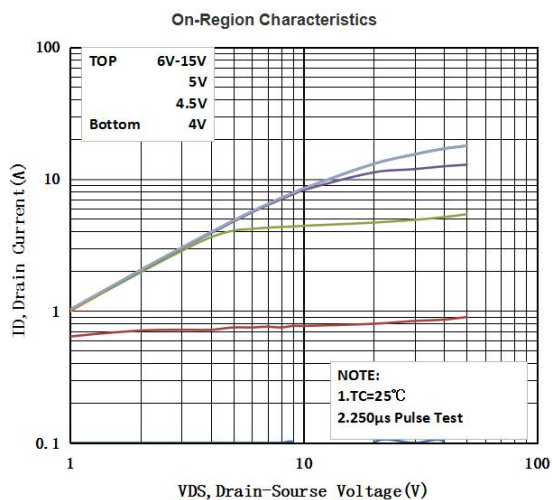

图2 导通电阻与漏极电流和栅极电压曲线

Fig2 On-Resistance Vs.Drain Current and Gate Voltage

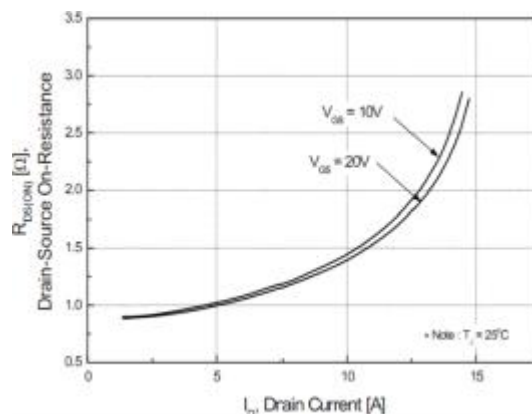

图3 导通电阻与温度曲线

Fig3 Normalized On-Resistance Vs.Temperature

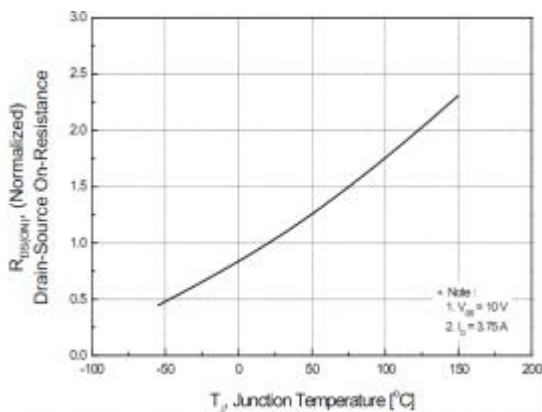

图4 二极管正向电压曲线

Fig4 Typical Source-Drain Diode Forward Voltage

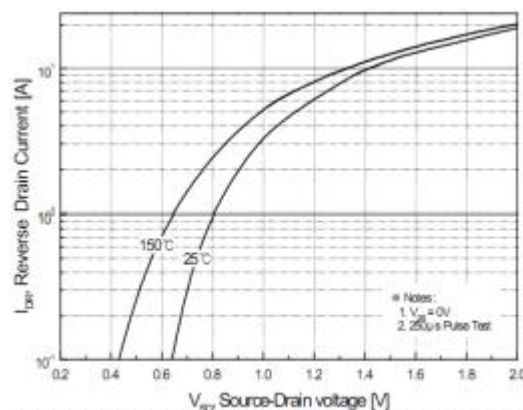

图5 最大漏极电流与壳温曲线

Fig5 Maximum Drain Current Vs.Case Temperature

N-沟道功率 MOS 管/ N-CHANNEL POWER MOSFET

SIF7N60F

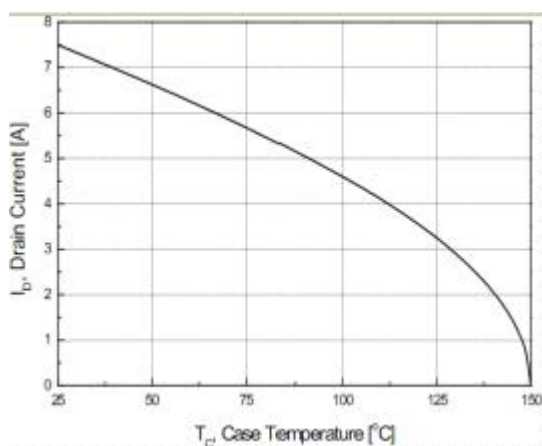
● 特性曲线



图 6-1 SIF7N60F(TO-220/262/263)
最大安全工作区曲线
Fig6-1 Maximum Safe Operating Area



图 6-2 SIF7N60F(TO-220FP)
最大安全工作区曲线
Fig6-2 Maximum Safe Operating Area

TO-220 封装机械尺寸 TO-220 MECHANICAL DATA

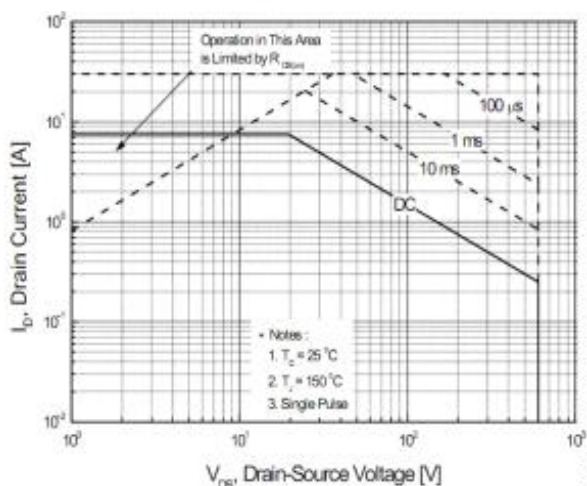
单位：毫米/UNIT: mm

符号 SYMBOL	最小值 min	典型值 nom	最大值 max	符号 SYMBOL	最小值 min	典型值 nom	最大值 max
A	4.00		4.80	E	9.90		10.70
B	1.20		1.50	e		2.54	
B1	1.00		1.40	F	1.10		1.45
b1	0.65		1.00	L	12.50		14.50
c	0.35		0.75	L1	3.00	3.50	4.00
D	15.00		16.50	Q	2.50		3.00
D1	5.90		6.90	Q1	2.00		3.00
				φP	3.60		3.90

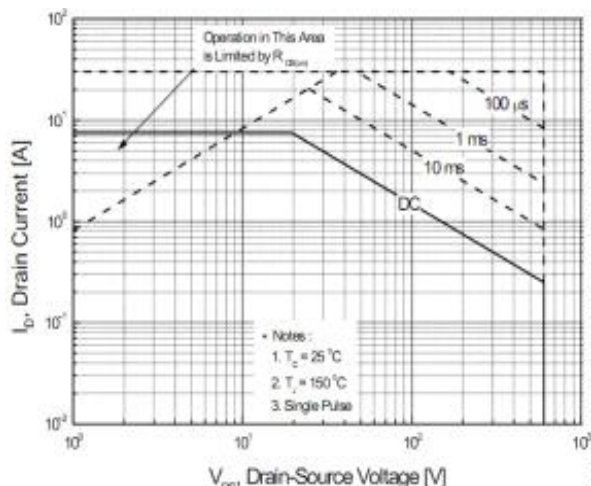
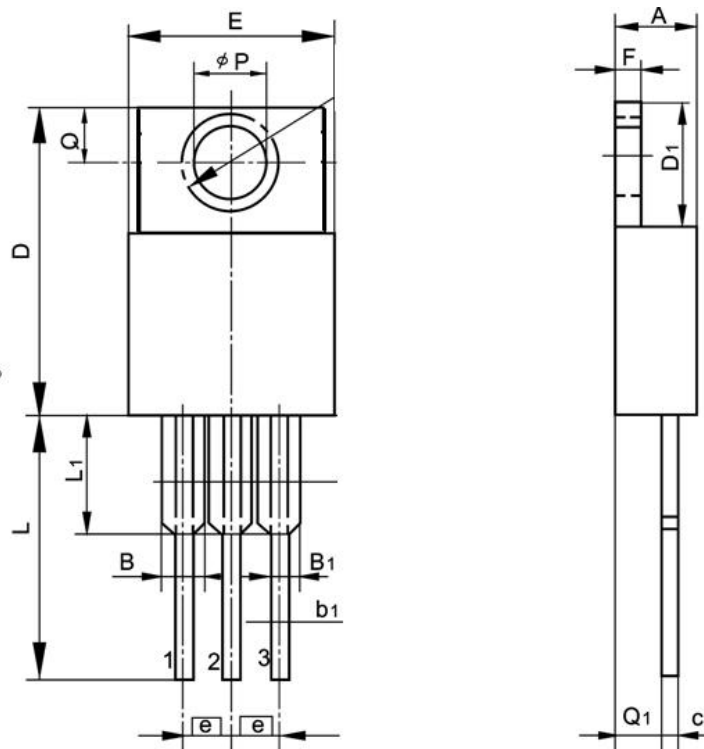

TO-220FP 封装机械尺寸 TO-220FP MECHANICAL DATA

单位:毫米/UNIT: mm

符号 SYMBOL	最小值 min	典型值 nom	最大值 max	符号 SYMBOL	最小值 min	典型值 nom	最大值 max
A	4.40		4.95	E	9.60		10.30
A ₁	2.30		2.90	e		2.54	
b	0.70		0.90	L	12.40		14.00
b ₁	1.18		1.45	L₂	2.30		2.60
c	0.40		0.70	L ₃	3.00		4.00
D	14.50		17.00	øp	3.00		3.50
D1	6.10		9.00	Q	2.30		2.80

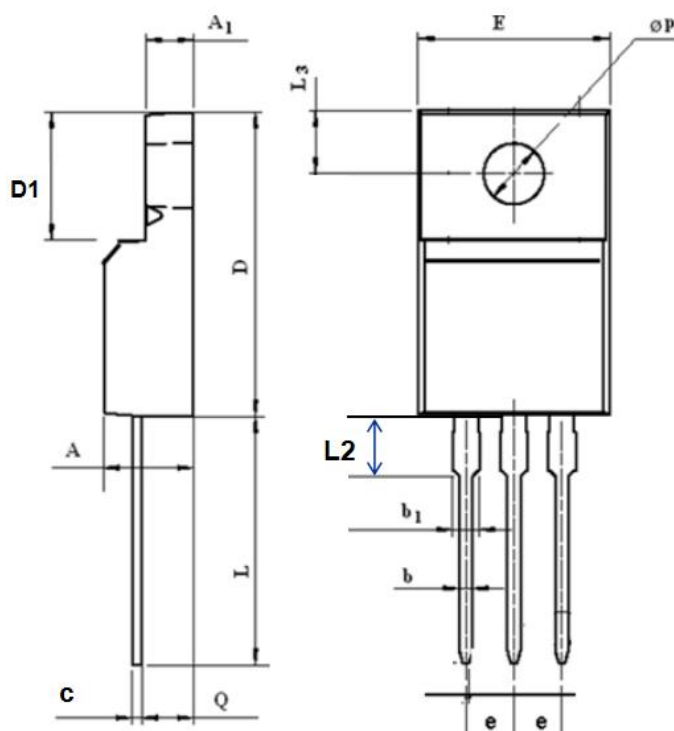

TO-220FPL 封装机械尺寸 TO-220FPL MECHANICAL DATA

单位:毫米/UNIT: mm

符号 SYMBOL	最小值 min	典型值 nom	最大值 max	符号 SYMBOL	最小值 min	典型值 nom	最大值 max
A	9.90		10.36	a	1.08		1.48
B	15.40		16.40	a1	0.70		0.90
B1	3.05		3.55	E	2.34		2.75
C	4.40		5.00	C1	2.25		2.85
c	0.40		0.60	C2	2.45		3.05
b	12.40		13.50	R	2.90		3.35
b1	2.60		3.60				L

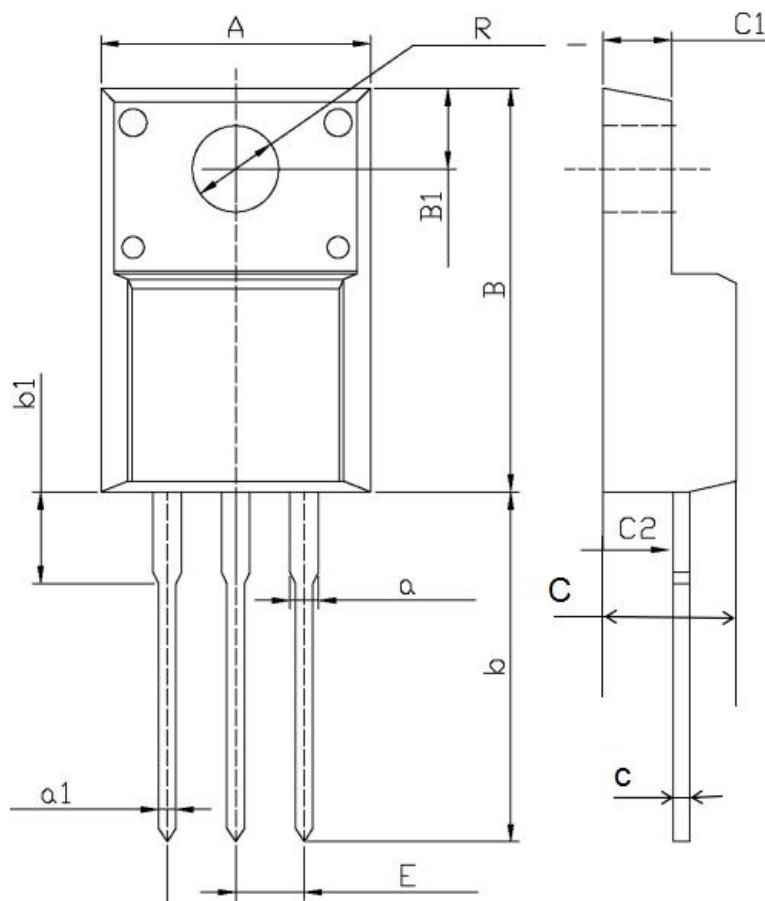

TO-262 封装机械尺寸 TO-262 MECHANICAL DATA

单位：毫米/UNIT: mm

符号 SYMBOL	最小值 min	典型值 nom	最大值 max	符号 SYMBOL	最小值 min	典型值 nom	最大值 max
A	3.80		4.80	e		2.54	
A1	2.00		2.80	e1			5.30
b	0.60		1.00	E	9.90		10.70
b1	1.20		1.40	L	12.50		14.50
c	0.40		0.70	L1	0.80	1.00	1.20
c2	1.10		1.40	L2			1.50
D			9.60				

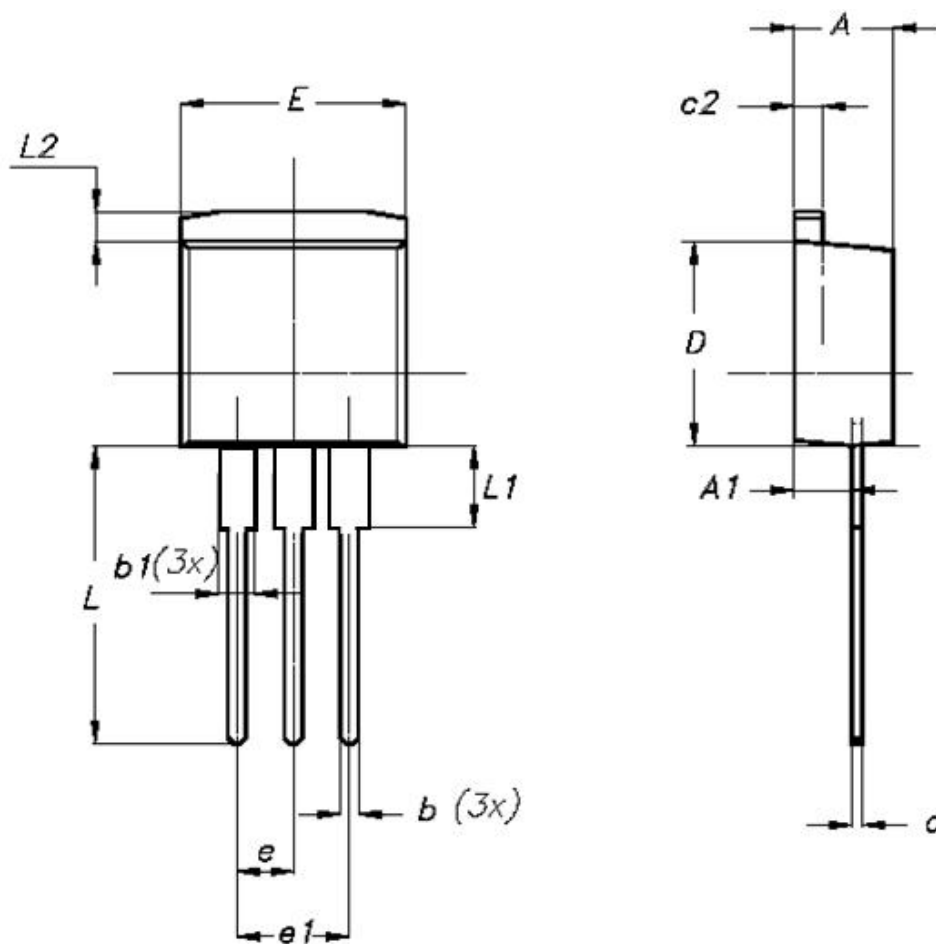

TO-263 封装机械尺寸

TO-263(D2PAK) MECHANICAL DATA

单位：毫米/UNIT: mm

符号 SYMBOL	最小值 min	典型值 nom	最大值 max	符号 SYMBOL	最小值 min	典型值 nom	最大值 max
A	4.42		4.72	E	8.99		9.29
B	1.22		1.32	e1	2.44		2.64
b	0.76		0.86	e2	4.98		5.18
b1	1.22		1.32	L1	15.19		15.79
b2	0.33		0.43	L2	2.29		2.79
C	1.22		1.32	L3	1.30		1.75
D	9.95		10.25				

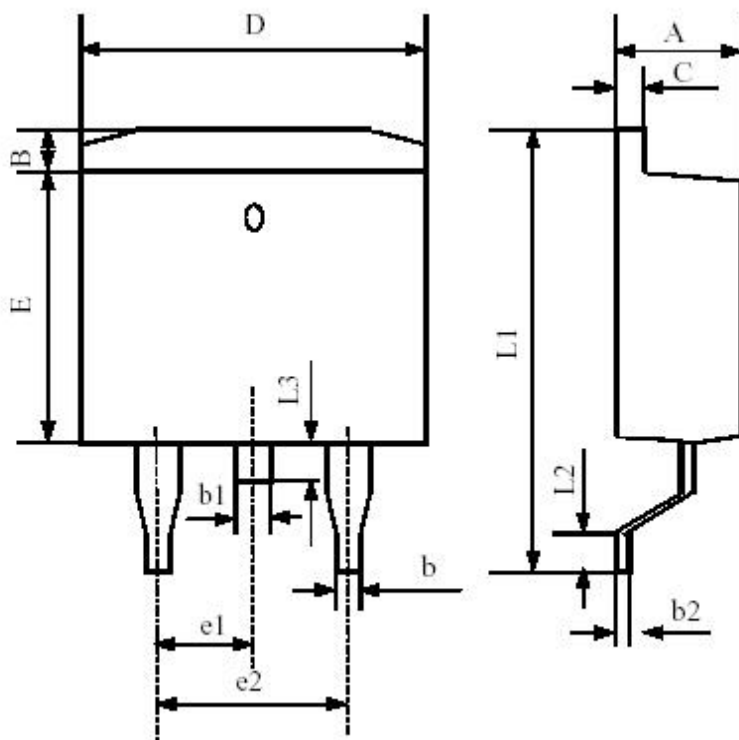

X-ON Electronics

Largest Supplier of Electrical and Electronic Components

Click to view similar products for [MOSFET](#) category:

Click to view products by [SI](#) manufacturer:

Other Similar products are found below :

[614233C](#) [648584F](#) [IRFD120](#) [IRFF430](#) [JANTX2N5237](#) [2N7000](#) [FCA20N60_F109](#) [FDZ595PZ](#) [AOD464](#) [2SK2267\(Q\)](#) [2SK2545\(Q,T\)](#)
[405094E](#) [423220D](#) [MIC4420CM-TR](#) [VN1206L](#) [614234A](#) [715780A](#) [SSM6J414TU,LF\(T](#) [751625C](#) [PSMN4R2-30MLD](#)
[TK31J60W5,S1VQ\(O](#) [2SK2614\(TE16L1,Q\)](#) [DMN1017UCP3-7](#) [EFC2J004NUZTDG](#) [FCAB21350L1](#) [P85W28HP2F-7071](#) [DMN1053UCP4-7](#)
[NTE2384](#) [NTE2969](#) [NTE6400A](#) [DMN2080UCB4-7](#) [DMN61D9UWQ-13](#) [US6M2GTR](#) [DMN31D5UDJ-7](#) [SSM6P54TU,LF](#) [DMP22D4UFO-](#)
[7B](#) [IPS60R3K4CEAKMA1](#) [DMN1006UCA6-7](#) [DMN16M9UCA6-7](#) [STF5N65M6](#) [STU5N65M6](#) [C3M0021120D](#) [DMN13M9UCA6-7](#)
[BSS340NWH6327XTSA1](#) [MCM3400A-TP](#) [DMTH10H4M6SPS-13](#) [IRF40SC240ARMA1](#) [IPS60R1K0PFD7SAKMA1](#)
[IPS60R360PFD7SAKMA1](#) [IPS60R600PFD7SAKMA1](#)