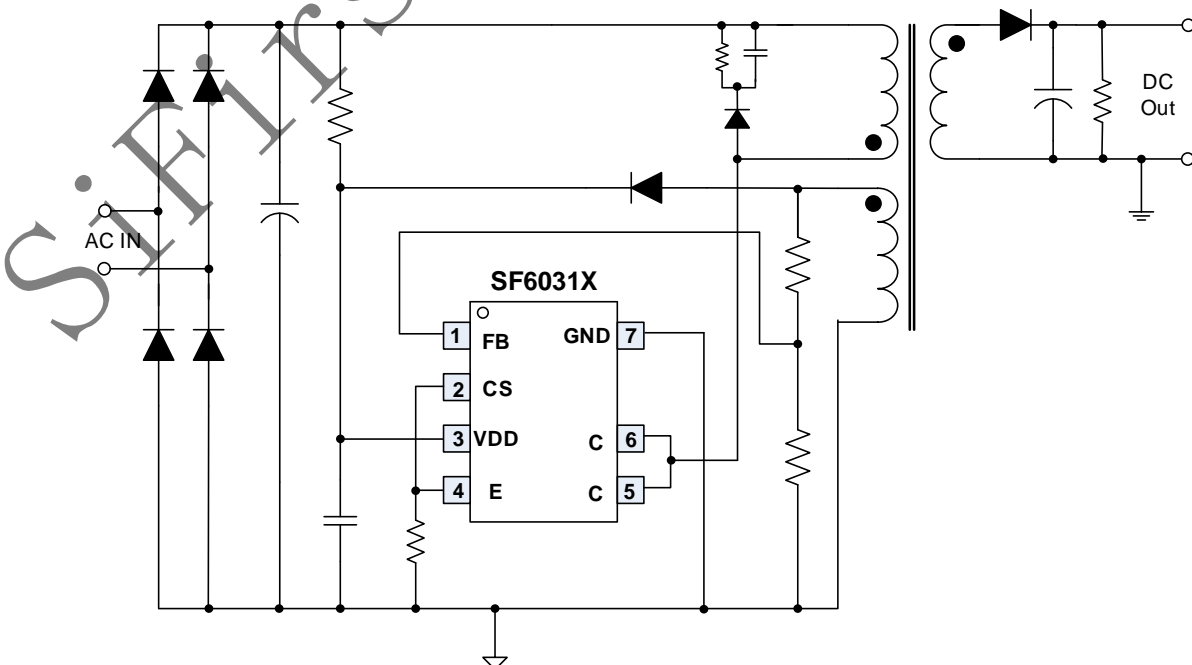

NC-Cap/super-QR/PSR-II™ CV/CC Power Switch
FEATURES

- ◆ Built-in High Voltage Power BJT
- ◆ Proprietary NC-Cap/super-QR/PSR-II™ (Quasi-Resonant & Primary Side Regulation) Control:
 - ±4% CC and CV Precision
 - Proprietary “Audio Noise Cancellation” Control
 - Built-in “Fast Dynamic Response” Control to Meet USB Charge Requirements
 - Proprietary “Zero-Output Startup” Control
 - Proprietary “Smart Output Short Protection” without External Compensation/Filtering Capacitor Needed
 - Max. 50V Output for AC/DC LED Lighting
- ◆ Direct Drive of Low Cost BJT
- ◆ Proprietary Cable Drop Compensation
- ◆ Multi Mode Control
- ◆ Frequency Jitter for Better EMI
- ◆ Dynamic Base Drive for High Efficiency
- ◆ Wide VDD Operating Range
- ◆ 10.8V UVLO Hysteresis Window
- ◆ Cycle-by-Cycle Current Limiting
- ◆ Leading Edge Blanking (LEB)
- ◆ Built-in Soft Start, Pin Floating Protection
- ◆ VDD UVLO, OVP, VOUT OVP, OLP, SCP

APPLICATIONS

- ◆ Battery chargers
- ◆ Replaces linear transformer and RCC SMPS
- ◆ Small power adapter
- ◆ AC/DC LED lighting

TYPICAL APPLICATION

GENERAL DESCRIPTION

SF6031X is a high precision, highly integrated DCM (Discontinuous Conduction Mode) Primary Side Regulation (PSR) power switch for offline small power converter applications. It has built-in power BJT, which can further lower system cost.

SF6031X has built-in proprietary **NC-Cap/super-QR/PSR-II™** control for CV control, which eliminates external compensation or filtering capacitor. It has built-in cable drop compensation function, which can provide excellent CV performance. The IC uses Multi Mode Control to improve efficiency and reliability and to decrease audio noise energy @ light loadings.

SF6031X integrates proprietary “**Audio Noise Cancellation**” control for audio noise free operation. The IC has built-in “**Fast Dynamic Response**” control to meet USB Charge requirements. SF6031X also integrates proprietary “**Zero-Output Startup**” control to achieve startup when output is near zero voltage. The IC has proprietary “**Smart Output Short Protection**”, which can protect the system with large leakage inductance when output is short circuit.

SF6031X integrates functions and protections of FB Short Protection, Under Voltage Lockout (UVLO), VDD Over Voltage Protection (VDD OVP), VOUT Over Voltage Protection (VOUT OVP), Output Over Load Protection (OLP), Output Short Circuit Protection (SCP), Soft Start, Cycle-by-cycle Current Limiting (OCP), Pin Floating Protection, VDD Clamping.

SF6031X is available SOP7 packages.

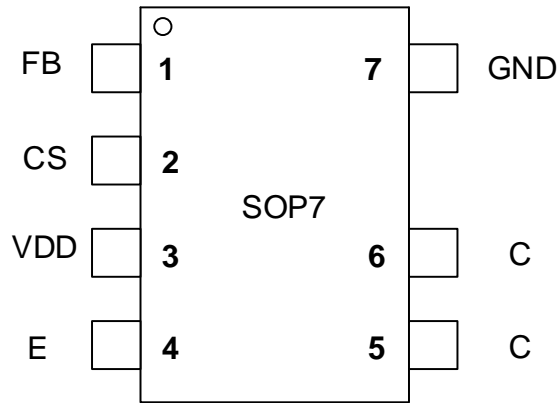
Pin Configuration

Ordering Information

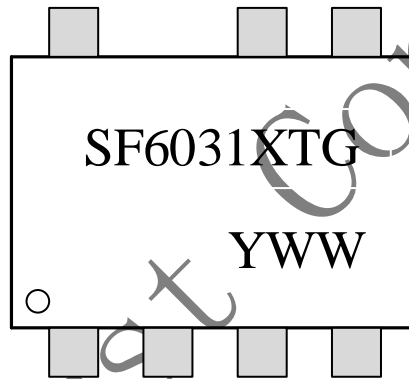
Part Number	Top Mark	BJT	Package		Tape & Reel
SF6031ATGT	SF6031ATG	0.5A	SOP7	Green	Yes
SF6031BTGT	SF6031BTG	0.8A	SOP7	Green	Yes
SF6031CTGT	SF6031CTG	1.0A	SOP7	Green	Yes
SF6031DTGT	SF6031DTG	1.5A	SOP7	Green	Yes
SF6031ETGT	SF6031ETG	1.8A	SOP7	Green	Yes
SF6031FTGT	SF6031FTG	2.0A	SOP7	Green	Yes

Marking Information

X: BJT code

- A: 0.5A
- B: 0.8A
- C: 1.0A
- D: 1.5A
- E: 1.8A
- F: 2.0A

YWW: Year&Week code

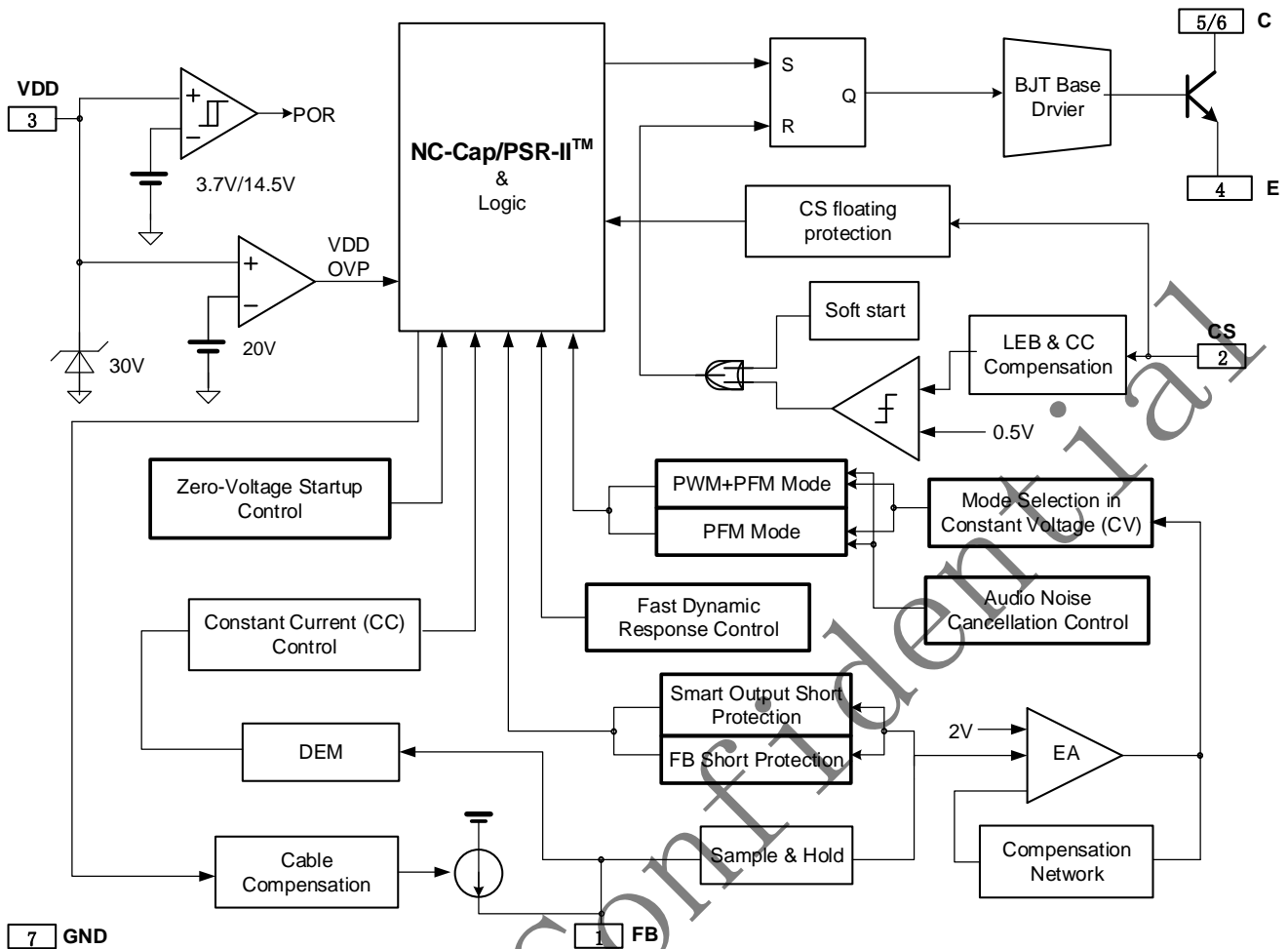
Block Diagram

Pin Description

Pin Num	Pin Name	I/O	Description
1	FB	I	System feedback pin. This control input regulates both the output voltage in CV mode and output current in CC mode based on the flyback voltage of the auxiliary winding.
2	CS	I	Current sense pin.
3	VDD	P	IC power supply pin.
4	E	P	High voltage power BJT emitter pin.
5-6	C	P	High voltage power BJT collector pin.
7	GND	P	Ground

Recommended Operation Conditions (Note 1)

Parameter	Value	Unit
Supply Voltage, VDD	7 to 16	V
Operating Ambient Temperature	-40 to 85	°C
Maximum Switching Frequency	70K	Hz

Absolute Maximum Ratings (Note 2)

Parameter	Value	Unit
VDD DC Supply Voltage	22	V
VDD DC Clamp Current	10	mA
CS voltage range	-0.3 to 7	V
FB voltage range	-0.7 to 7	V
Collector to Emitter Voltage	850	V
Package Thermal Resistance (SOP-7)	θ_{JA}	120 °C/W
	θ_{JC}	60 °C/W
Maximum Junction Temperature	150	°C
Operating Temperature Range	-40 to 85	°C
Storage Temperature Range	-65 to 150	°C
Lead Temperature (Soldering, 10sec.)	260	°C
ESD Capability, HBM (Human Body Model)	3	kV
ESD Capability, MM (Machine Model)	250	V

ELECTRICAL CHARACTERISTICS

 (T_A = 25°C, VDD=14V, if not otherwise noted)

Symbol	Parameter	Test Conditions	Min	Typ	Max	Unit
Supply Voltage (VDD) Section						
I_Startup	VDD Start up Current	VDD = UVLO(OFF)-1V		1	3	uA
I_VDD_Op	Operation Current	VDD=14V		0.8	1.5	mA
UVLO(OFF)	VDD Under Voltage Lockout Exit (Startup)		13.5	14.5	15.5	V
UVLO(ON)	VDD Under Voltage Lockout Enter		3.4	3.7	4	V
VDD_OVP	VDD Over Voltage Protection trigger		18	20	22	V
T_Softstart	Soft Start Time			2		mSec
Feedback Input Section(FB Pin)						
V_FB_EA_Ref	Internal Error Amplifier(EA) reference input		1.98	2.0	2.02	V
V_FB_DEM	Demagnetization comparator threshold			25		mV
T_min_OFF	Minimum OFF time			2		uSec
T_max_OFF	Maximum OFF time			3.3		mSec
V_FB_Short	Output Short Circuit Threshold			1.2		V
T_FB_Short	Output Short Circuit Debounce Time			65		mSec
V_FB_OVP	Output Over Voltage Protection Threshold			2.8		V
T _{CC} /T _{DEM}	Ratio between switching period in CC mode and demagnetization time			2		
I _{Cable_max}	Max Cable compensation current			60		uA
Current Sense Input Section (CS Pin)						
T_blanking	CS Leading Edge Blanking Time			500		nSec
V _{th_OC_max}	Max. Current limiting threshold		490	500	510	mV
T _{D_OC}	Over Current Detection and Control Delay			100		nSec

Power BJT Section							
BV _{CEO}	6031A	Collector-emitter breakdown voltage	I _C =1mA	450			V
	6031B		I _C =10mA	480			
	6031C		I _C =10mA	480			
	6031D		I _C =10mA	450			
	6031E		I _C =10mA	450			
	6031F		I _C =10mA	450			
BV _{CBO}	6031A	Collector-base breakdown voltage	I _C =1mA	750			V
	6031B		I _C =1mA	800			
	6031C		I _C =1mA	850			
	6031D		I _C =1mA	800			
	6031E		I _C =1mA	800			
	6031F		I _C =1mA	800			
BV _{EBO}	6031A	Emitter-base breakdown voltage	I _E =1mA	11			V
	6031B		I _E =1mA	9			
	6031C		I _E =1mA	11			
	6031D		I _E =1mA	9			
	6031E		I _E =1mA	9			
	6031F		I _E =1mA	9			
V _{CE(sat)}	6031A	Collector-emitter saturation voltage	I _C =100mA, I _B =20mA			0.6	V
	6031B		I _C =50mA, I _B =10mA			0.5	
	6031C		I _C =100mA, I _B =20mA			0.5	
			I _C =500mA, I _B =100mA			0.8	
	6031D		I _C =0.5A, I _B =0.1A			0.25	
			I _C =1.5A, I _B =0.5A			0.75	
	6031E		I _C =1.0A, I _B =0.2A			0.4	
	6031F		I _C =1.0A, I _B =0.2A			0.4	
H _{fe}	6031A	DC current gain	V _{CE} =20V, I _C =20mA	20		30	
	6031B		V _{CE} =5V, I _C =100mA	20		30	
	6031C		V _{CE} =5V, I _C =100mA	20		30	
	6031D		V _{CE} =5V, I _C =0.2A	15		20	
	6031E		V _{CE} =6.5V, I _C =0.2A	20		30	
	6031F		V _{CE} =5V, I _C =1.0A	15		25	

Note 1. Stresses beyond those listed under "Absolute Maximum Ratings" may cause permanent damage to the device. These are stress ratings only, and functional operation of the device at these or any other conditions beyond those indicated in the operational sections of the specifications is not implied. Exposure to absolute maximum rating conditions for extended periods may affect device reliability.

Note 2. The device is not guaranteed to function outside its operating conditions.

OPERATION DESCRIPTION

SF6031X is a high performance, highly integrated DCM (Discontinuous Conduction Mode) Primary Side Regulation (PSR) power switch. The built-in high precision CV/CC control makes it very suitable for offline small power converter applications.

◆ PSR Technology Introduction

Assuming the system works in DCM mode, the power transfer function is given by

$$P = \frac{\eta}{2} \times L_m \times I_{pk}^2 \times f_s = V_o \times I_o \quad (\text{Eq.1})$$

In the equation above, P is output power, Vo and Io are system output voltage and current respectively, η is system power transfer efficiency, Lm is transformer primary inductance, fs is system switching frequency, Ipk is primary peak current in a switching cycle. The following figure illustrates the waveform in a switching cycle.

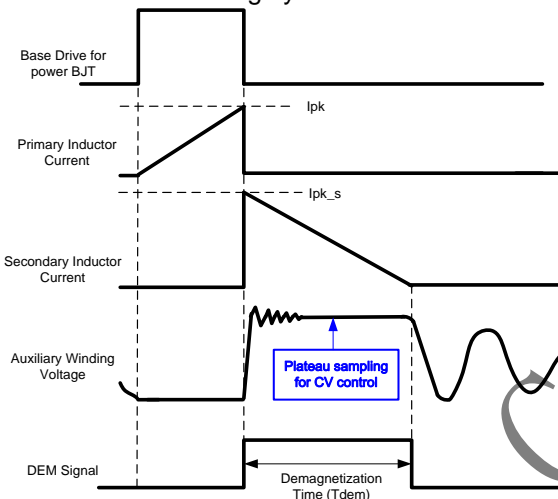

Fig.1

In the figure shown above, the IC generates a demagnetization signal (DEM) in each switching cycle through auxiliary winding. Tdem is demagnetization time for CV/CC control. In DCM mode, Tdem can be expressed as;

$$\frac{V_o}{L_m} \times T_{dem} = \frac{N_s}{N_p} \times I_{pk} \quad (\text{Eq.2})$$

In Eq.2, Np and Ns are primary and secondary winding turns respectively.

Combined with Eq.1 and Eq. 2, the average output current can be expressed as:

$$I_o = \frac{\eta}{2} \times I_{pk} \times \frac{N_p}{N_s} \times f_s \times T_{dem} \quad (\text{Eq.3})$$

CC (Constant Current) Control Scheme

From Eq.3, it can be easily seen that there are two ways to implement CC control: one is PFM (Pulse Frequency Modulation), the control scheme is to keep Ipk to be constant, let the product of Ts and Tdem (fs*Tdem) to be a constant. In this way, Io will be a value independent to the variation of Vo,

Lm, and line input voltage. Another realization method is PWM duty control, the control scheme is to keep fs to be constant, let the product of Tdem and Ipk (Tdem*Ipk) to be a constant, in another words, by modulating system duty cycle to realize a constant Io independent to the variation of Vo, Lm and line voltages.

SF6031X adopts PFM for CC control, the product of Ts and Tdem is given by

$$f_s \times T_{dem} = 0.5 \quad (\text{Eq.4})$$

CV (Constant Voltage) Control Scheme

CV control should sample the plateau of auxiliary winding voltage in flyback phase, as shown in Fig.1 The CV control has many implementations, for example, PWM, or PFM, or a combination of both one. In SF6031X, the CV control adopts proprietary multi mode control, as mention below.

The output voltage can be sensed via the auxiliary winding. During MOSFET turn-off time, the energy stored in the primary winding is transferred to the secondary side. The auxiliary voltage reflects the output voltage as shown in Fig.1 and it is given by

$$V_{aux} = \frac{N_{aux}}{N_s} \times (V_o + \Delta V) \quad (\text{Eq.5})$$

Where ΔV indicates the voltage drop of the output diode.

As shown in Fig.2, via a resistor divider connected between the auxiliary winding and FB (pin 1), the auxiliary voltage is sampled at the middle of the demagnetization and it is hold until the next sampling. The sampled voltage is compared with reference voltage (typical 2.0V) and the difference is amplified. The error amplifier output reflects the load condition and controls the switching off time to regulate the output voltage, thus constant output voltage can be achieved.

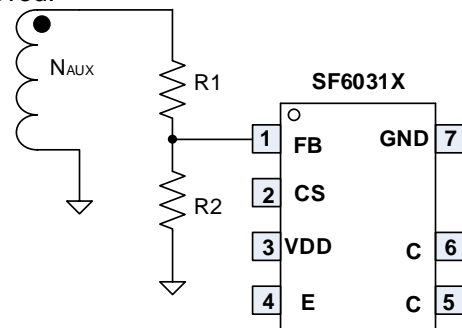

Fig.2

◆ Startup Current / Startup Control / Operating Current

Startup current of SF6031X is designed to be very low (typically 1uA) so that VDD could be charged up above UVLO(OFF) threshold level and device starts up quickly. The operating current in SF6031X is as small as 0.8mA (typical). The small operating current results in higher efficiency and reduces the VDD hold-up capacitance requirement.

◆ **NC-Cap/PSR-II™ Introduction**

● **±4% Precision CV/CC Performance**

SF6031X can achieve less than ±4% variation of CC/CV precision due to the built-in CV accuracy improvement and CC line and load compensation, as shown in Fig.3.

● **Proprietary “Audio Noise Cancellation” Control**

SF6031X has a proprietary “Audio Noise Cancellation” control, which can achieve audio noise free operation in the whole loading range.

● **Built-in Fast Dynamic Response Control to Meet USB Charge Requirements**

In SF6031X, a fast dynamic response control is integrated to improve system dynamic response performance, thus the charger system can meet the USB charge requirements.

● **Smart Output Short Protection**

The output short circuit protection of conventional PSR system is based on the coupling between auxiliary winding and secondary winding. When output is short, the auxiliary winding cannot provide enough energy to the IC any more. In this way, the system will enter into auto-recovery mode protection. However, the IC may be wrongly supplied if the leakage inductance of the primary winding is large enough.

In SF6031X, if output short circuit occurs, the IC will detect the situation and enter into auto-recovery mode protection.

● **Proprietary Zero-Output Startup Control**

Conventional PSR system may suffer startup failure when output voltage is near zero voltage, which means that there is a gap between OCP (CC point in PSR CV/CC system) and full loading. Larger OCP gap causes larger system cost.

In SF6031X, a proprietary “Zero-Output Startup Control” is adopted to achieve successful startup @ $V_{out} \approx 0V$, as shown in Fig.3.

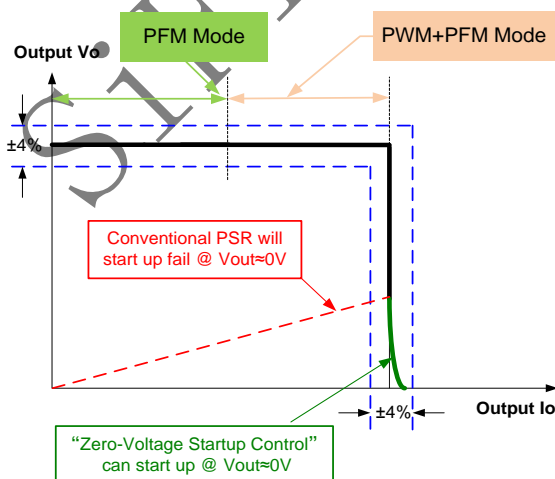

Fig.3

● **No External Compensation/Filtering Capacitor Needed**

SF6031X uses a proprietary control to eliminate external compensation capacitor, which can simplify system design and lower system cost.

● **Maximum 50V Output for LED Lighting**

SF6031X can support maximum 50V output, which can be used in AC/DC LED lighting.

◆ **Proprietary Cable Drop Compensation**

SF6031X has a proprietary built-in cable voltage drop compensation block which can provide a constant output voltage at the end of the cable over the entire load range in CV mode.

◆ **Multi Mode PSR Control for High Reliability , High Efficiency**

Conventional pure PFM controlled PSR system may suffer transformer saturation issue when heavy loading. In SF6031X, a proprietary multi mode control is adopted to suppress this issue, as shown in Fig.3. Around the full load, the system operates in PWM+PFM mode, which improve the system reliability. Under normal to light load conditions, the IC operates in PFM mode to achieve excellent regulation and high efficiency.

◆ **Soft Start**

SF6031X features an internal 2ms (typical) soft start that slowly increases the threshold of cycle-by-cycle current limiting comparator during startup sequence. Every startup process is followed by a soft start activation.

◆ **Leading Edge Blanking (LEB)**

Each time the power BJT is switched on, a turn-on spike occurs across the sensing resistor. To avoid premature termination of the switching pulse, an internal leading edge blanking circuit is built in. During this blanking period (500ns, typical), the cycle-by-cycle current limiting comparator is disabled and cannot switch off the base driver.

◆ **Minimum and Maximum OFF Time**

In SF6031X, a minimum OFF time (typically 2us) is implemented to suppress ringing when BASE drive is pull off. The maximum OFF time in SF6031X is typically 3.3ms, which provides a large range for frequency reduction. In this way, low standby power can be achieved.

◆ **Pin Floating Protection**

In SF6031X, if pin floating situation occurs, the IC is designed to have no damage to system.

◆ **Built-in Load and AC Line CC Compensation**

In conventional PSR system, the output CC (Constant Current) point can vary with output and AC line voltage. In SF6031X the IC has built-in

blocks to compensate the variation, as shown in Fig4. The IC can adjust CC point based on sensed output voltage and PFM duty. In this way, CC accuracy can be improved.

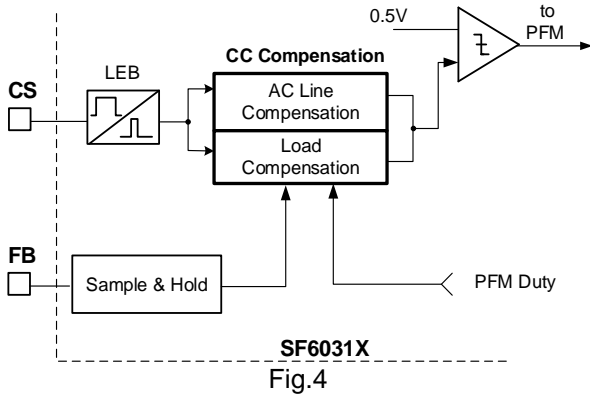

◆ Auto Recovery Mode Protection

As shown in Fig.5, once a fault condition is detected, switching will stop. This will cause VDD to fall because no power is delivered from the auxiliary winding. When VDD falls to UVLO(on) (typical 3.7V), the protection is reset and the operating current reduces to the startup current, which causes VDD to rise. However, if the fault still exists, the system will experience the above mentioned process. If the fault has gone, the system resumes normal operation. In this manner, the auto restart can alternatively enable and disable the switching until the fault condition is disappeared.

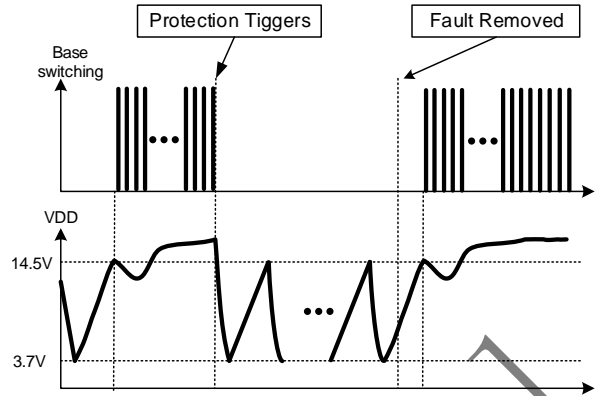

Fig.5

◆ VDD Over Voltage Protection

VDD OVP is implemented in SF6031X and it is a protection of auto-recovery mode. If VDD is higher than 20V (TYP), VDD OVP protection will be triggered and the switch is turned off until VDD is lower than UVLO(on) (typical 3.7V).

◆ VOUT Over Voltage Protection

If FB voltage during the sampling time is higher than OVP voltage (typical 2.8V), the counter will start to work. VOUT OVP protection will be triggered when the counter is counted to 3 continuously, and the switch is turned off until VDD is lower than UVLO(on) (typical 3.7V).

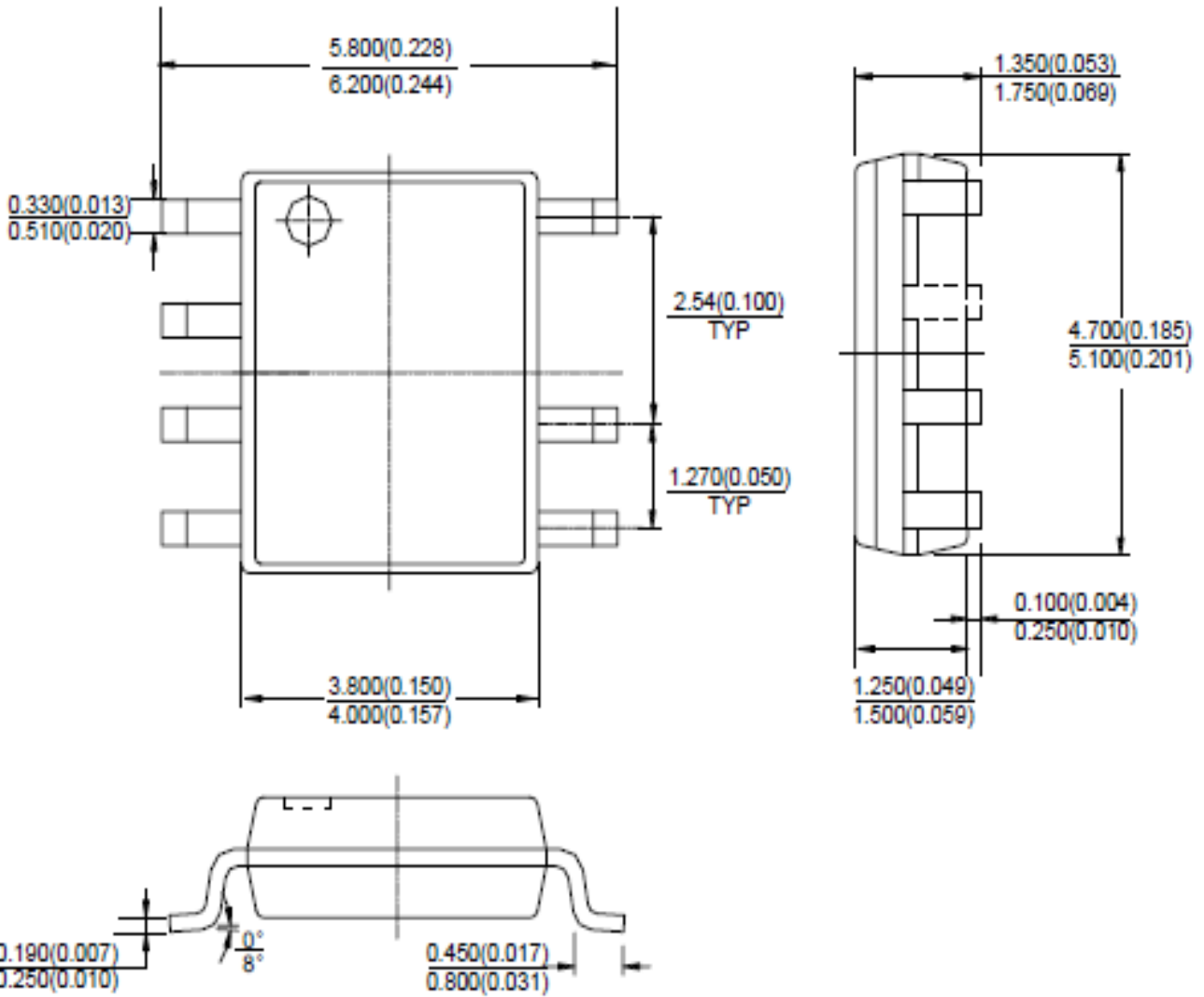
PACKAGE MECHANICAL DATA
SOIC-7
Unit: mm(inch)

Note: Eject hole, oriented hole and mold mark is optional.

IMPORTANT NOTICE

SiFirst Technology Nanhai, Ltd (SiFirst) reserves the right to make corrections, modifications, enhancements, improvements and other changes to its products and services at any time and to discontinue any product or service without notice. Customers should obtain the latest relevant information before placing orders and should verify that such information is current and complete.

SiFirst warrants performance of its hardware products to the specifications applicable at the time of sale in accordance with SiFirst's standard warranty. Testing and other quality control techniques are used to the extent SiFirst deems necessary to support this warranty. Except where mandated by government requirements, testing of all parameters of each product is not necessarily performed.

SiFirst assumes no liability for application assistance or customer product design. Customers are responsible for their products and applications using SiFirst's components. To minimize the risks associated with customer products and applications, customers should provide adequate design and operating safeguards.

Reproduction of SiFirst's information in SiFirst's data books or data sheets is permissible only if reproduction is without alteration and is accompanied by all associated warranties, conditions, limitations, and notices. Reproduction of this information with alteration is an unfair and deceptive business practice. SiFirst is not responsible or liable for such altered documentation. Information of third parties may be subject to additional restrictions.

Resale of SiFirst's products or services with statements different from or beyond the parameters stated by SiFirst for that product or service voids all express and any implied warranties for the associated SiFirst's product or service and is an unfair and deceptive business practice. SiFirst is not responsible or liable for any such statements.

SiFirst's products are neither designed nor intended for use in military applications. SiFirst will not be held liable for any damages or claims resulting from the use of its products in military applications.

SiFirst's products are not designed to be used as components in devices intended to support or sustain human life. SiFirst will not be held liable for any damages or claims resulting from the use of its products in medical applications.

X-ON Electronics

Largest Supplier of Electrical and Electronic Components

Click to view similar products for [Power Switch ICs - Power Distribution](#) category:

Click to view products by [Sifirst](#) manufacturer:

Other Similar products are found below :

[NCP45520IMNTWG-L](#) [TCK111G,LF\(S](#) [FSDM0365RNB](#) [FPF1018](#) [DS1222](#) [TCK2065G,LF](#) [SZNCP3712ASNT3G](#) [TLE7244SL](#) [MIC2033-05BYMT-T5](#) [MIC2033-12AYMT-T5](#) [MIC2033-05BYM6-T5](#) [SLG5NT1437VTR](#) [SZNCP3712ASNT1G](#) [DML1008LDS-7](#) [KTS1640QGDV-TR](#) [KTS1641QGDV-TR](#) [TS13011-QFNR](#) [TLE7240SLXUMA4](#) [NCV459MNWTBG](#) [NCP4545IMNTWG-L](#) [NCV8412ASTT1G](#) [NCV8412ASTT3G](#) [FPF2260ATMX](#) [SLG59M1557VTR](#) [BD2222G-GTR](#) [NCP45780IMN24RTWG](#) [NCP45540IMNTWG-L](#) [MC10XS6200EK](#) [MC10XS6225EK](#) [MC25XS6300EK](#) [MC33882PEP](#) [MC10XS6325EK](#) [TPS2021IDRQ1](#) [TPS2103D](#) [TPS22954DQCR](#) [TPS22958NDGKR](#) [TPS22958NDGNR](#) [TPS22959DNYT](#) [TPS22994RUKR](#) [TPS2561AQDRCRQ1](#) [MIC2005-0.5YML-TR](#) [MIC2098-1YMT-TR](#) [MIC2098-2YMT-TR](#) [MIC94062YMT TR](#) [MIC94064YMT-TR](#) [MIC94065YC6-TR](#) [MP6231DN-LF](#) [MP62551DGT-LF-P](#) [BTS117](#) [BTS500151TADATMA2](#)