



## Ultra-small 17 mΩ 2.5 A Load Switch with Discharge

### General Description

The SLG59M1448V is a 17 mΩ 2.5 A single-channel load switch that is able to switch 0.9 to 5 V power rails. The product is packaged in an ultra-small 1.0 x 1.6 mm package.

### Features

- 1.0 x 1.6 x 0.55 mm STDFN 8L package (2 fused pins for drain and 2 fused pins for source)
- Logic level ON pin capable of supporting 0.85 V CMOS Logic
- User selectable ramp rate with external capacitor
- 17 mΩ RDS<sub>ON</sub> while supporting 2.5 A
- Discharges load when off
- Two Over Current Protection Modes
  - Short Circuit Current Limit
  - Active Current Limit
- Over Temperature Protection
- Pb-Free / Halogen-Free / RoHS compliant
- Operating Temperature: -40 °C to 85°C
- Operating Voltage: 2.5 V to 5.5 V

### Pin Configuration

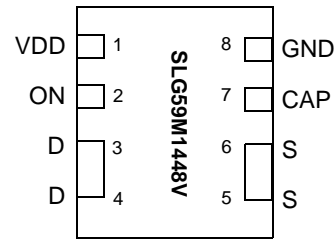

**8-pin STDFN  
(Top View)**

### Applications

- Notebook Power Rail Switching
- Tablet Power Rail Switching
- Smartphone Power Rail Switching

### Block Diagram

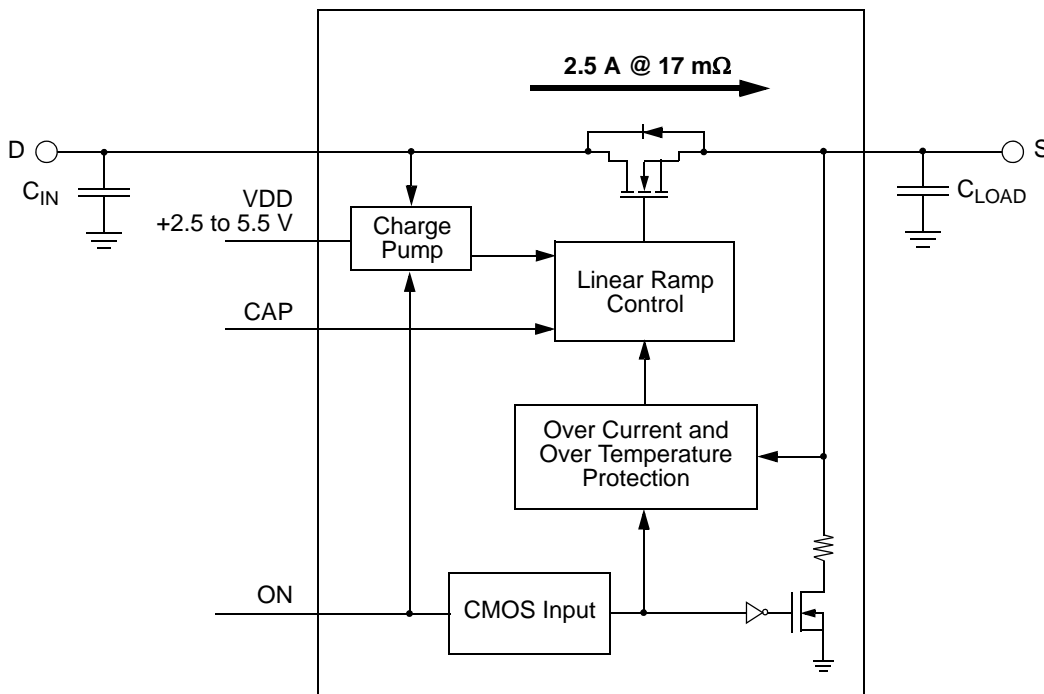



### Pin Description

Pin #	Pin Name	Type	Pin Description
1	VDD	PWR	VDD power for load switch control (2.5 V to 5.5 V)
2	ON	Input	Turns MOSFET ON (4 M $\Omega$ pull down resistor) CMOS input with VIL < 0.3 V, VIH > 0.85 V
3	D	MOSFET	Drain of Power MOSFET (fused with pin 4)
4	D	MOSFET	Drain of Power MOSFET (fused with pin 3)
5	S	MOSFET	Source of Power MOSFET (fused with pin 6)
6	S	MOSFET	Source of Power MOSFET (fused with pin 5)
7	CAP	Input	Capacitor for controlling power rail ramp rate
8	GND	GND	Ground

### Ordering Information

Part Number	Type	Production Flow
SLG59M1448V	STDFN 8L	Industrial, -40 °C to 85 °C
SLG59M1448VTR	STDFN 8L (Tape and Reel)	Industrial, -40 °C to 85 °C



## Absolute Maximum Ratings

Parameter	Description	Conditions	Min.	Typ.	Max.	Unit
V <sub>DD</sub>	Power Supply		--	--	7	V
T <sub>S</sub>	Storage Temperature		-65	--	150	°C
ESD <sub>HBM</sub>	ESD Protection	Human Body Model	8000	--	--	V
MSL	Moisture Sensitivity Level		1			
W <sub>DIS</sub>	Package Power Dissipation		--	--	0.4	W
MOSFET I <sub>DS</sub> <sub>PK</sub>	Peak Current from Drain to Source	For no more than 1 ms with 1% duty cycle	--	--	3.5	A

Note: Stresses greater than those listed under "Absolute Maximum Ratings" may cause permanent damage to the device. This is a stress rating only and functional operation of the device at these or any other conditions above those indicated in the operational sections of this specification is not implied. Exposure to absolute maximum rating conditions for extended periods may affect reliability.

## Electrical Characteristics

T<sub>A</sub> = -40 °C to 85 °C (unless otherwise stated)

Parameter	Description	Conditions	Min.	Typ.	Max.	Unit
V <sub>DD</sub>	Power Supply Voltage	-40 °C to 85 °C	2.5	--	5.5	V
I <sub>DD</sub>	Power Supply Current (PIN 1)	when OFF	--	--	1	μA
		when ON, No C <sub>LOAD</sub>	--	70	100	μA
R <sub>DS</sub> <sub>ON</sub>	Static Drain to Source ON Resistance	T <sub>A</sub> 25°C @ 100 mA	--	17	19	mΩ
		T <sub>A</sub> 70°C @ 100 mA	--	18.5	20	mΩ
		T <sub>A</sub> 85°C @ 100 mA	--	22	24	mΩ
I <sub>DS</sub>	Operating Current	V <sub>D</sub> = 1.0 V to 5.5 V	--	--	2.5	A
V <sub>D</sub>	Drain Voltage		0.9	--	V <sub>DD</sub>	V
T <sub>ON</sub> <sub>Delay</sub>	ON pin Delay Time	50% ON to Ramp Begin	0	300	500	μs
T <sub>Total</sub> <sub>ON</sub>	Total Turn On Time	50% ON to 90% V <sub>S</sub>	Configurable <sup>1</sup>			ms
		Example: CAP (PIN 7) = 4 nF, V <sub>DD</sub> = V <sub>D</sub> = 5 V, C <sub>LOAD</sub> = 10 μF, I <sub>DS</sub> = 100 mA	--	1.96	--	ms
T <sub>SLEW</sub> <sub>RATE</sub>	Slew Rate	10% V <sub>S</sub> to 90% V <sub>S</sub>	Configurable <sup>1</sup>			V/ms
		Example: CAP (PIN 7) = 4 nF, V <sub>DD</sub> = V <sub>D</sub> = 5 V, C <sub>LOAD</sub> = 10 μF, I <sub>DS</sub> = 100 mA	--	3.0	--	V/ms
C <sub>LOAD</sub>	Output Load Capacitance	C <sub>LOAD</sub> connected from V <sub>S</sub> to GND	--	--	500	μF
R <sub>DIS</sub>	Discharge Resistance		100	150	300	Ω
ON_V <sub>IH</sub>	High Input Voltage on ON pin		0.85	--	V <sub>DD</sub>	V
ON_V <sub>IL</sub>	Low Input Voltage on ON pin		-0.3	0	0.3	V
I <sub>LIMIT</sub>	Active Current Limit	MOSFET will automatically limit current when V <sub>S</sub> > 250 mV	--	3.7	--	A
	Short Circuit Current Limit	MOSFET will automatically limit current when V <sub>S</sub> < 250 mV	--	0.9	--	A
THERM <sub>ON</sub>	Thermal shutoff turn-on temperature		--	125	--	°C
THERM <sub>OFF</sub>	Thermal shutoff turn-off temperature		--	100	--	°C
THERM <sub>TIME</sub>	Thermal shutoff time		--	--	1	ms
T <sub>OFF</sub> <sub>Delay</sub>	OFF Delay Time	50% ON to V <sub>S</sub> Fall, V <sub>DD</sub> = V <sub>D</sub> = 5 V	--	8	--	μs



### Electrical Characteristics (continued)

T<sub>A</sub> = -40 °C to 85 °C (unless otherwise stated)

Parameter	Description	Conditions	Min.	Typ.	Max.	Unit
T <sub>FALL</sub>	V <sub>S</sub> Fall Time	90% V <sub>S</sub> to 10% V <sub>S</sub> , V <sub>DD</sub> = V <sub>D</sub> = 5 V	--	3.8	--	μs

Notes:

1. Refer to table for configuration details.



## SLG59M1448V Power-Up/Power-Down Sequence Considerations

To ensure glitch-free power-up under all conditions, apply  $V_{DD}$  first, followed by  $V_D$  after  $V_{DD}$  exceeds 1 V. Then allow  $V_D$  to reach 90% of its max value before toggling the ON pin from Low-to-High. Likewise, power-down in reverse order.

If  $V_{DD}$  and  $V_D$  need to be powered up simultaneously, glitching can be minimized by having a suitable load capacitor. A 10  $\mu$ F  $C_{LOAD}$  will prevent glitches for rise times of  $V_{DD}$  and  $V_D$  less than 2 ms.

If the ON pin is toggled HIGH before  $V_{DD}$  and  $V_D$  have reached their steady-state values, the IPS timing parameters may differ from datasheet specifications.

The slew rate of output  $V_S$  follows a linear ramp set by a capacitor connected to the CAP pin. A larger capacitor value at the CAP pin produces a slower ramp, reducing inrush current from capacitive loads.

## SLG59M1448V Current Limiting

The SLG59M1448V has two modes of current limiting, differentiated by the output (Source pin) voltage.

### 1. Standard Current Limiting Mode (with Thermal Protection)

When  $V(S) > 250$  mV, the output current is initially limited to the Active Current Limit specification given in the Electrical Characteristics table. The current limiting circuit is very fast and responds within a few micro-seconds to sudden loads. When overload is sensed, the current limiting circuit increases the FET resistance to keep the current from exceeding the Active Current Limit.

However, if an overload condition persists, the die temperature rise due to the increased FET resistance while at maximum current can activate Thermal Protection. If the die temperature exceeds the  $THERM_{ON}$  specification, the FET is shut completely OFF, allowing the die to cool. When the die cools to the  $THERM_{OFF}$  temperature, the FET is allowed to turn back on. This process may repeat as long as the overload condition is present.

### 2. Short Circuit Current Limiting Mode (with Thermal Protection)

When  $V(S) < 250$  mV (which is the case with a hard short, such as a solder bridge on the power rail), the current is limited to approximately 500 mA. Thermal Protection is also present, but since the Short Circuit Current Limit is much lower than Standard Current Limit, activation may only occur at higher ambient temperatures.

For more information on Silego GreenFET3 integrated power switch features, please visit our [Application Notes](#) page at our website and see [App Note "AN-1068 GreenFET3 Integrated Power Switch Basics"](#).



**T<sub>Total\_ON</sub> vs. CAP @ V<sub>DD</sub> = 3.3 V**

SLG59M1448V T<sub>Total\_ON</sub>: ON (50%) - V<sub>S</sub> (90%)  
V<sub>DD</sub> = 3.3 V, T<sub>A</sub> = 25 °C. C<sub>LOAD</sub> = 10 μF, I<sub>DS</sub> = 100 mA

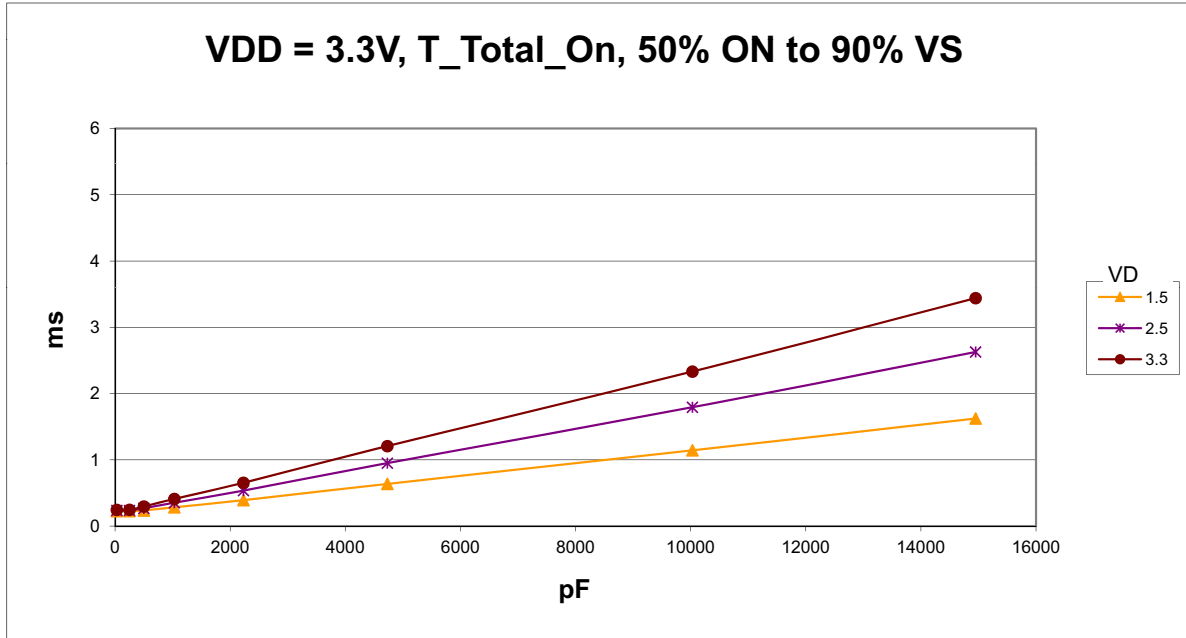

**T<sub>Total\_ON</sub> vs. CAP @ V<sub>DD</sub> = 5.0 V**

SLG59M1448V T<sub>Total\_ON</sub>: ON (50%) - V<sub>S</sub> (90%)  
V<sub>DD</sub> = 5.0 V, T<sub>A</sub> = 25 °C. C<sub>LOAD</sub> = 10 μF, I<sub>DS</sub> = 100 mA

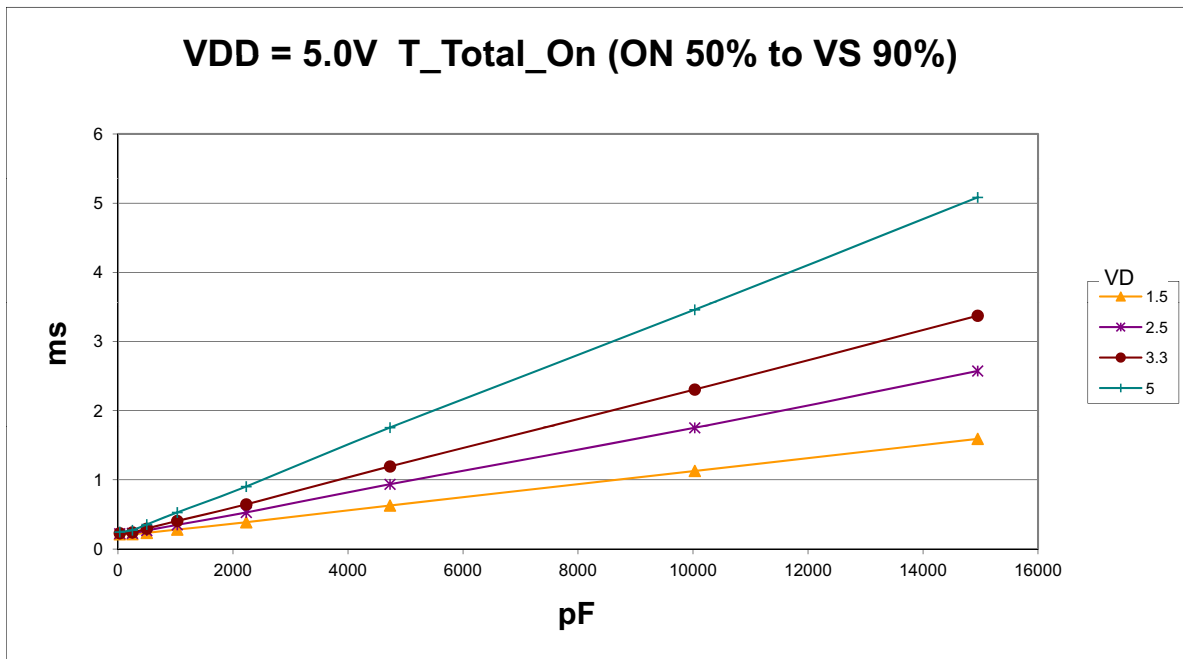



### $T_{SLEW}$ vs. CAP @ $V_{DD} = 3.3$ V

SLG59M1448V  $T_{SLEW}$ :  $V_S$  (10%) -  $V_S$  (90%)  
 $V_{DD} = 3.3$  V,  $T_A = 25$  °C.  $C_{LOAD} = 10$   $\mu$ F,  $I_{DS} = 100$  mA



### $T_{SLEW}$ vs. CAP @ $V_{DD} = 5.0$ V

SLG59M1448V  $T_{SLEW}$ :  $V_S$  (10%) -  $V_S$  (90%)  
 $V_{DD} = 5.0$  V,  $T_A = 25$  °C.  $C_{LOAD} = 10$   $\mu$ F,  $I_{DS} = 100$  mA

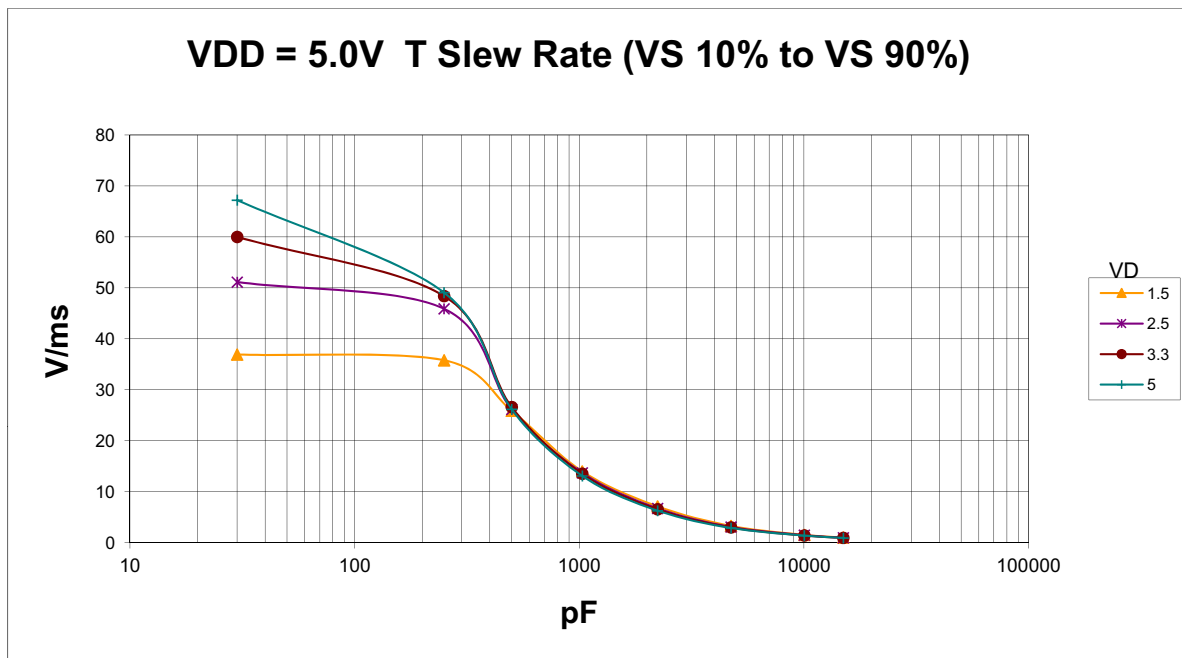



### $T_{Total\_ON}$ , $T_{ON\_Delay}$ and Slew Rate Measurement

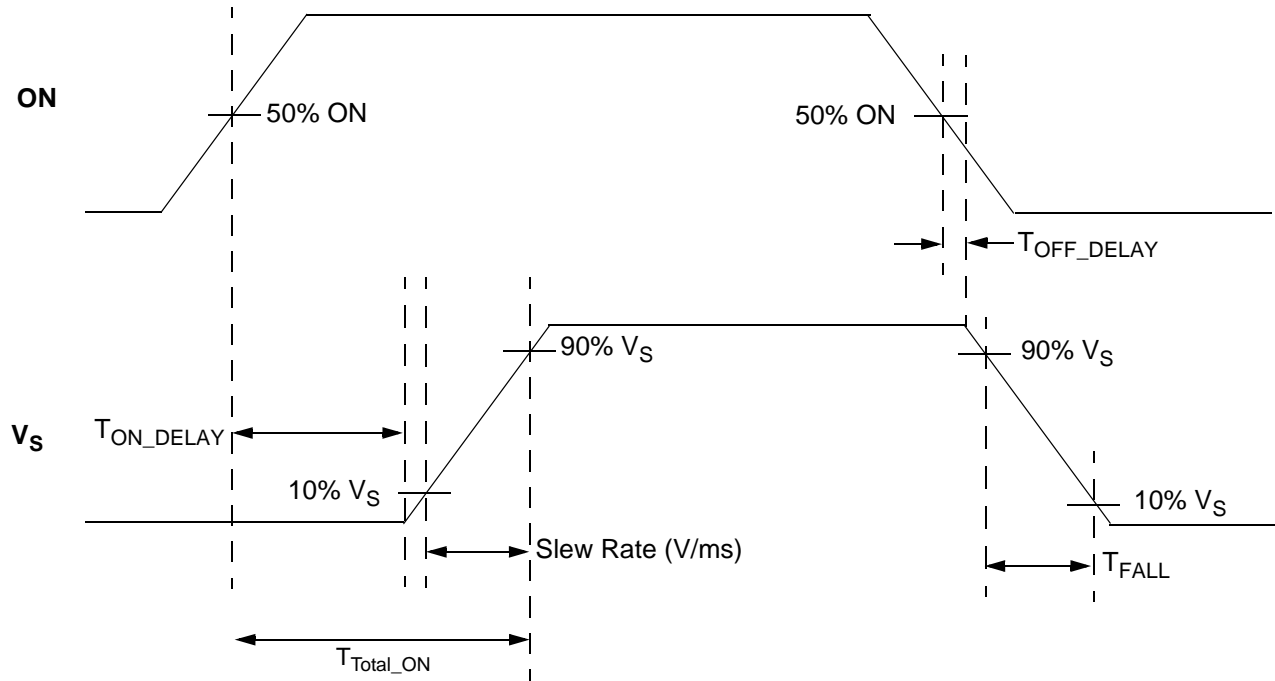





---

Package Top Marking System Definition

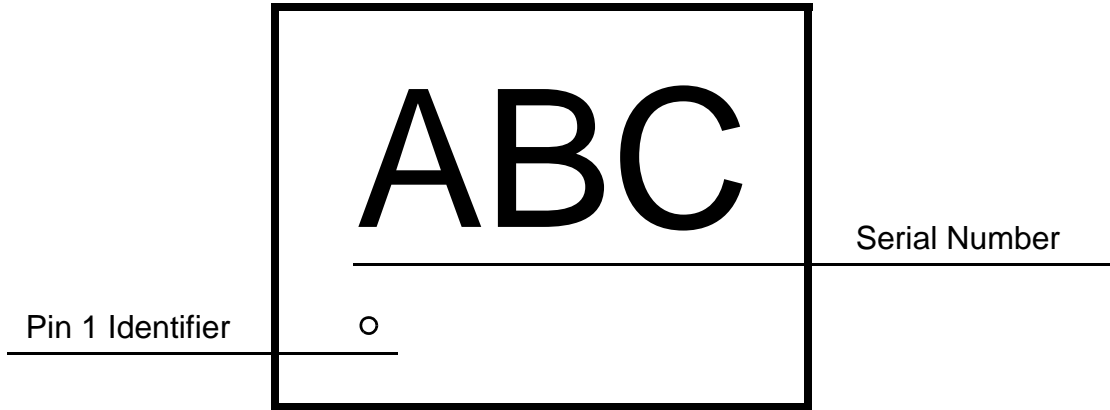



### Package Drawing and Dimensions

8 Lead STDFN Package 1.0 x 1.6 mm (Fused Lead)

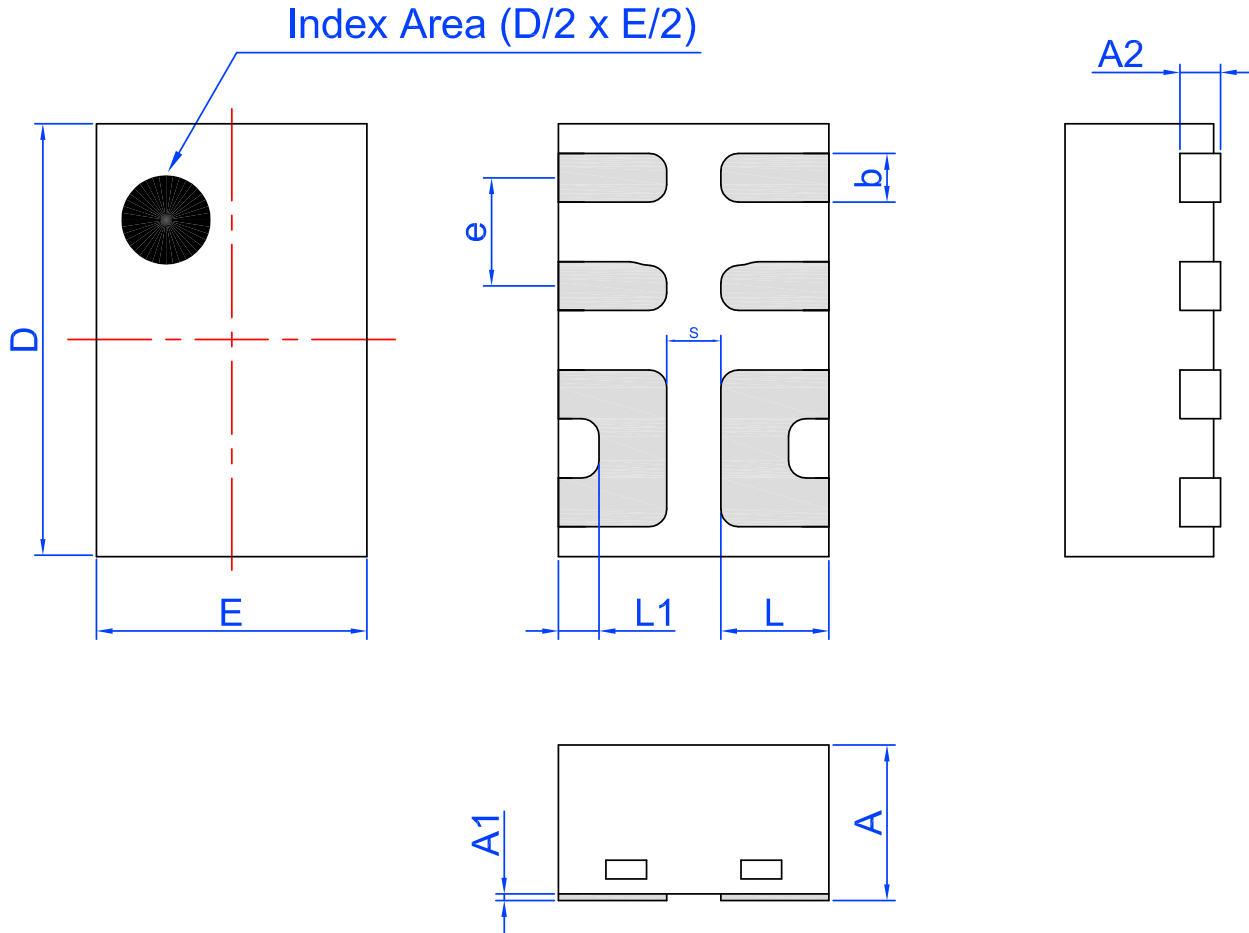

Unit: mm

Symbol	Min	Nom.	Max	Symbol	Min	Nom.	Max
A	0.50	0.55	0.60	D	1.55	1.60	1.65
A1	0.005	-	0.060	E	0.95	1.00	1.05
A2	0.10	0.15	0.20	L	0.35	0.40	0.45
b	0.13	0.18	0.23	L1	0.10	0.15	0.20
e	0.40 BSC			S	0.2 REF		



**Tape and Reel Specifications**

Package Type	# of Pins	Nominal Package Size [mm]	Max Units		Reel & Hub Size [mm]	Leader (min)		Trailer (min)		Tape Width [mm]	Part Pitch [mm]
			per Reel	per Box		Pockets	Length [mm]	Pockets	Length [mm]		
STDFN 8L 1x1.6mm 0.4P FC Green	8	1.0 x 1.6 x 0.55	3,000	3,000	178 / 60	100	400	100	400	8	4

**Carrier Tape Drawing and Dimensions**

Package Type	Pocket BTM Length	Pocket BTM Width	Pocket Depth	Index Hole Pitch	Pocket Pitch	Index Hole Diameter	Index Hole to Tape Edge	Index Hole to Pocket Center	Tape Width
	A0	B0	K0	P0	P1	D0	E	F	W
STDFN 8L 1x1.6mm 0.4P FC Green	1.12	1.72	0.7	4	4	1.55	1.75	3.5	8

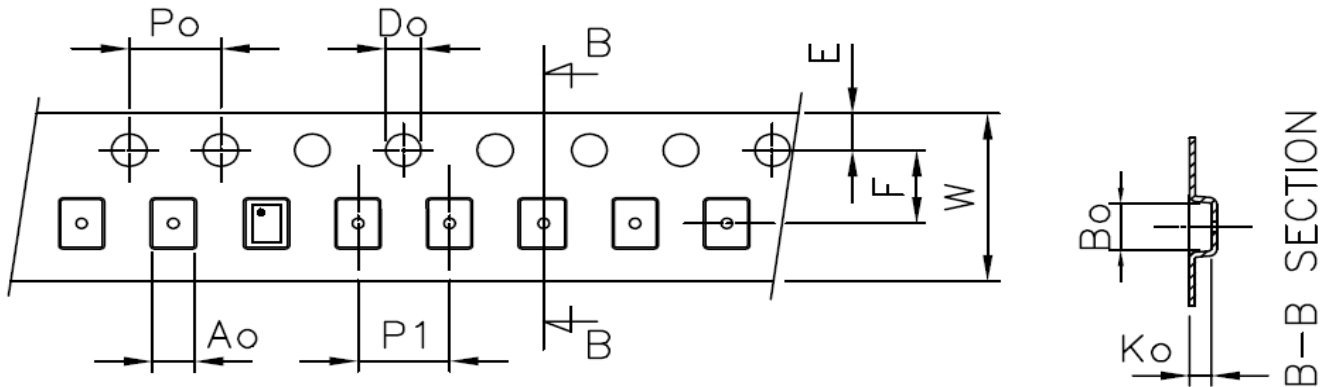

**Recommended Reflow Soldering Profile**

Please see IPC/JEDEC J-STD-020: latest revision for reflow profile based on package volume of 0.88 mm<sup>3</sup> (nominal). More information can be found at [www.jedec.org](http://www.jedec.org).



---

### Revision History

Date	Version	Change
8/31/2016	1.06	Updated Power up/down Sequencing Considerations
5/10/2016	1.05	Updated Power up/down Sequence section Updated Parameter names for clarity

## X-ON Electronics

Largest Supplier of Electrical and Electronic Components

*Click to view similar products for [Power Switch ICs - Power Distribution](#) category:*

*Click to view products by [Silego](#) manufacturer:*

Other Similar products are found below :

[TCK111G,LF\(S\)](#) [FPF1018](#) [DS1222](#) [TCK2065G,LF](#) [SZNCP3712ASNT3G](#) [MIC2033-05BYMT-T5](#) [MIC2033-12AYMT-T5](#) [MIC2033-05BYM6-T5](#) [SLG5NT1437VTR](#) [SZNCP3712ASNT1G](#) [NCV330MUTBG](#) [DML1008LDS-7](#) [KTS1670EDA-TR](#) [KTS1640QGDV-TR](#) [KTS1641QGDV-TR](#) [NCV459MNWTBG](#) [FPF2260ATMX](#) [U6513A](#) [U6119S](#) [NCP45780IMN24RTWG](#) [MAX14919ATP+](#) [MC33882PEP](#) [TPS2021HDRQ1](#) [TPS2104DBVR](#) [MIC2098-1YMT-TR](#) [MIC94062YMT TR](#) [MP6231DN-LF](#) [MIC2075-2YM](#) [MIC2095-2YMT-TR](#) [MIC94068YML-TR](#) [SIP32461DB-T2-GE1](#) [NCP335FCT2G](#) [FPF2701MX](#) [TCK105G,LF\(S\)](#) [AP2151DSG-13](#) [MIC94094YC6-TR](#) [MIC94064YC6-TR](#) [MIC2505-1YM](#) [MIC94042YFL-TR](#) [MIC94041YFL-TR](#) [MIC2005-1.2YM6-TR](#) [TPS2032QDRQ1](#) [SIP32510DT-T1-GE3](#) [NCP333FCT2G](#) [NCP331SNT1G](#) [TPS2092DR](#) [TPS2063DR](#) [TPS2042P](#) [MIC2008YML-TR](#) [MIC2040-1YMM](#)