



## 30 mΩ, 2.0 A Nanopower Mobile Integrated Power Switch with Discharge

### General Description

The SLG59M1460V is a 30 mΩ 2.0 A single-channel load switch that is able to switch 0.85 to 3.3 V power rails. The product is packaged in an ultra-small 1.0 x 1.6 mm package.

### Features

- 1.0 x 1.6 x 0.55 mm STDFN 8L package (2 fused pins for drain and 2 fused pins for source)
- Logic level ON pin capable of supporting 0.85 V CMOS Logic
- Discharged Load when off
- Fast Turn On time
- Low RDS<sub>ON</sub> while supporting 2.0 A
- Pb-Free / Halogen-Free / RoHS compliant
- Operating Temperature: -20 °C to 70°C
- Operating Voltage: 2.5 V to 5.25 V

### Pin Configuration

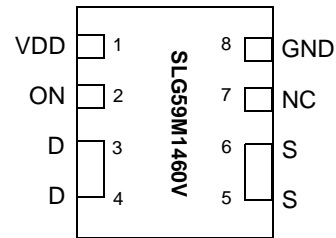

**8-pin STDFN**  
(Top View)

### Applications

- Watch Power Rail Switching
- Tablet Power Rail Switching
- Smartphone Power Rail Switching

### Block Diagram

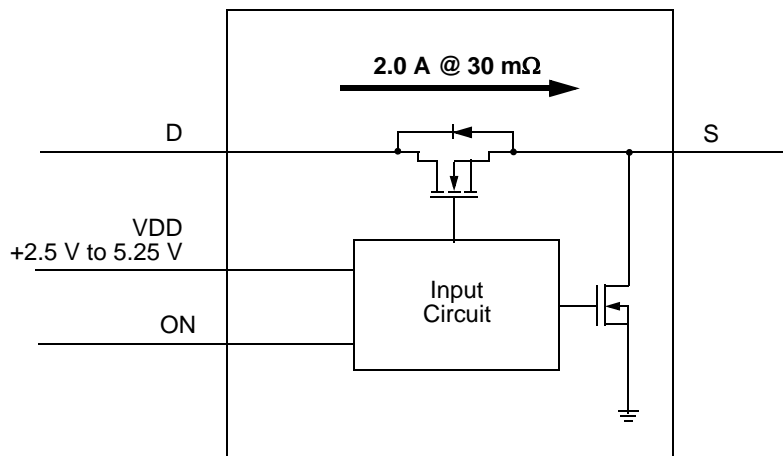



### Pin Description

Pin #	Pin Name	Type	Pin Description
1	VDD	PWR	VDD power for load switch control (2.5 V to 5.25 V)
2	ON	Input	Turns MOSFET ON (4 M $\Omega$ pull down resistor) CMOS input with VIL < 0.3 V, VIH > 0.85 V
3	D	MOSFET	Drain of Power MOSFET (fused with pin 4)
4	D	MOSFET	Drain of Power MOSFET (fused with pin 3)
5	S	MOSFET	Source of Power MOSFET (fused with pin 6)
6	S	MOSFET	Source of Power MOSFET (fused with pin 5)
7	NC	NC	No Connect. Must leave this pin floating. Do not connect to VDD or GND
8	GND	GND	Ground

### Ordering Information

Part Number	Type	Production Flow
SLG59M1460V	STDFN 8L	Commercial, -20 °C to 70 °C
SLG59M1460VTR	STDFN 8L (Tape and Reel)	Commercial, -20 °C to 70 °C

### SLG59M1460V RDS<sub>ON</sub>

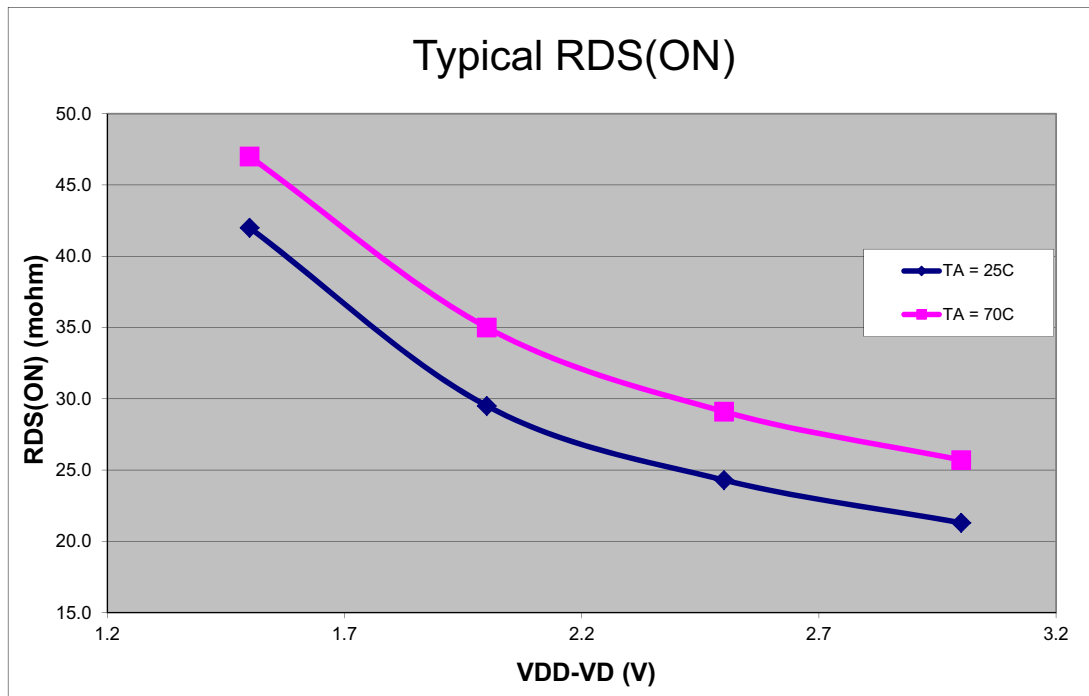



## Absolute Maximum Ratings

Parameter	Description	Conditions	Min.	Typ.	Max.	Unit
$V_{DD}$	Power Supply		--	--	7	V
$T_S$	Storage Temperature		-65	--	150	°C
$ESD_{HBM}$	ESD Protection	Human Body Model	2000	--	--	V
$W_{DIS}$	Package Power Dissipation		--	--	0.4	W
MOSFET $IDS_{PK}$	Peak Current from Drain to Source	For no more than 1 ms with 1% duty cycle	--	--	3.5	A

Note: Stresses greater than those listed under "Absolute Maximum Ratings" may cause permanent damage to the device. This is a stress rating only and functional operation of the device at these or any other conditions above those indicated in the operational sections of this specification is not implied. Exposure to absolute maximum rating conditions for extended periods may affect reliability.

## Electrical Characteristics

$T_A = -20$  to  $70$  °C (unless otherwise stated)

Parameter	Description	Conditions	Min.	Typ.	Max.	Unit
$V_{DD}$	Power Supply Voltage	-20 to 70°C	2.5	--	5.25	V
$I_{DD}$	Power Supply Current (PIN 1)	when OFF	--	30	100	nA
		when ON, No load	--	150	300	nA
$RDS_{ON}$	Static Drain to Source ON Resistance	$T_A$ 25°C @ 100 mA, $V_{DD} - V_D = 1.5$ V	--	42.0	46.0	mΩ
		$T_A$ 25°C @ 100 mA, $V_{DD} - V_D = 2.0$ V	--	29.5	35.0	mΩ
		$T_A$ 25°C @ 100 mA, $V_{DD} - V_D = 2.5$ V	--	24.3	30.0	mΩ
		$T_A$ 25°C @ 100 mA, $V_{DD} - V_D = 3.0$ V	--	21.3	25.0	mΩ
$RDS_{ON}$	Static Drain to Source ON Resistance	$T_A$ 70°C @ 100 mA, $V_{DD} - V_D = 1.5$ V	--	47.0	50.0	mΩ
		$T_A$ 70°C @ 100 mA, $V_{DD} - V_D = 2.0$ V	--	35.0	38.0	mΩ
		$T_A$ 70°C @ 100 mA, $V_{DD} - V_D = 2.5$ V	--	29.1	32.0	mΩ
		$T_A$ 70°C @ 100 mA, $V_{DD} - V_D = 3.0$ V	--	25.7	29.0	mΩ
$IDS$	Operating Current	$V_D = 1.0$ V to 3.3 V	--	--	2.0	A
$V_D$	Drain Voltage		0.85	--	$V_{DD} - 1.5$	V
$T_{Total\_ON}$	Total Turn On Time	50% ON to 90% $V_S$ , $V_{DD} = 2.5$ V, $V_D = 1.0$ V, 10 μF Load, $IDS = 100$ mA	--	64	75	μs
		50% ON to 90% $V_S$ , $V_{DD} = 5.25$ V, $V_D = 1.0$ V, 10 μF Load, $IDS = 100$ mA	--	28	40	μs
$T_{SLEWRATE}$	Slew Rate	10% $V_S$ to 90% $V_S$ , $V_{DD} = 2.5$ V, $V_D = 1.0$ V, 10 μF Load, $IDS = 100$ mA	--	23	25	V/ms
		10% $V_S$ to 90% $V_S$ , $V_{DD} = 5.25$ V, $V_D = 1.0$ V, 10 μF Load, $IDS = 100$ mA	--	64	70	V/ms
$CAP_{SOURCE}$	Source Cap	Source to GND	--	--	10	μF
$R_{DIS}$	Discharge Resistance		100	150	300	Ω
ON_ $V_{IH}$	High Input Voltage on ON pin		0.85	--	$V_{DD}$	V
ON_ $V_{IL}$	Low Input Voltage on ON pin		-0.3	0	0.3	V
$T_{OFF\_Delay}$	OFF Delay Time	50% ON to $V_S$ Fall, $V_{DD} = 2.5$ V, $V_D = 1.0$ V, 0.1 μF Load, 10 Ω	--	36	45	μs
$T_{FALL}$	$V_S$ Fall Time	90% $V_S$ to 10% $V_S$ , $V_{DD} = 2.5$ V, $V_D = 1.0$ V, 0.1 μF Load, 10 Ω	--	42	--	μs



$T_{Total\_ON}$ ,  $T_{ON\_Delay}$  and Slew Rate Measurement

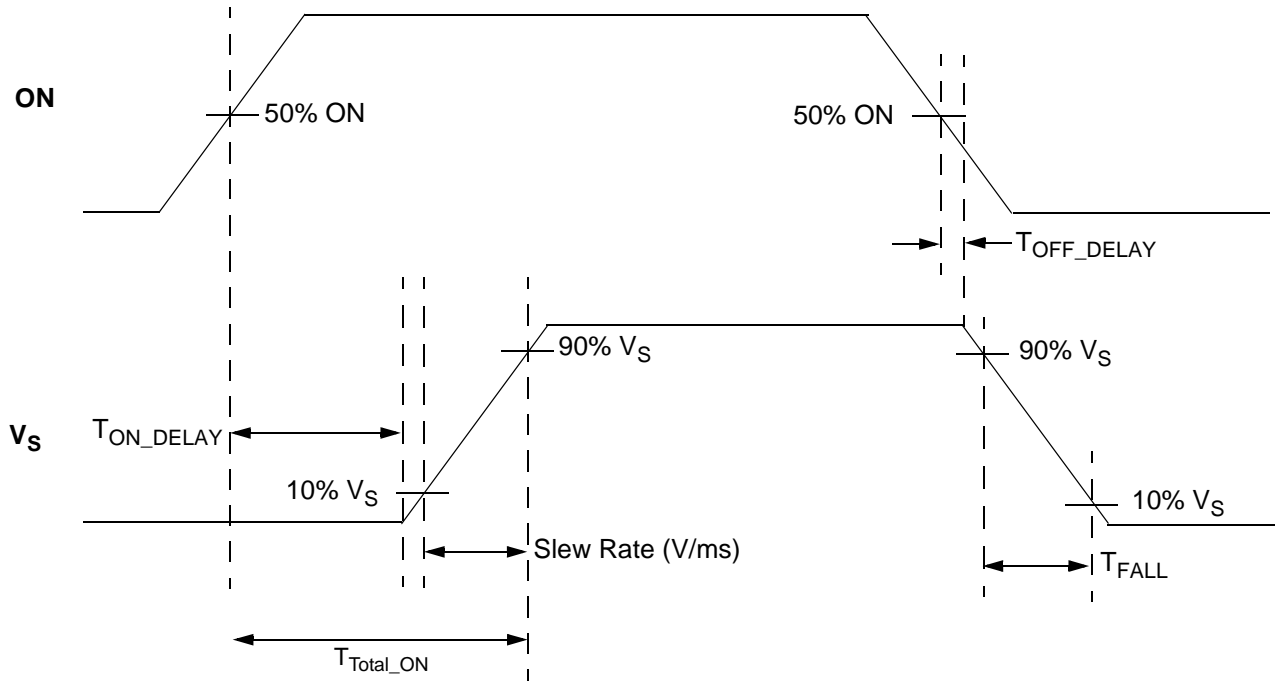



---

Package Top Marking System Definition

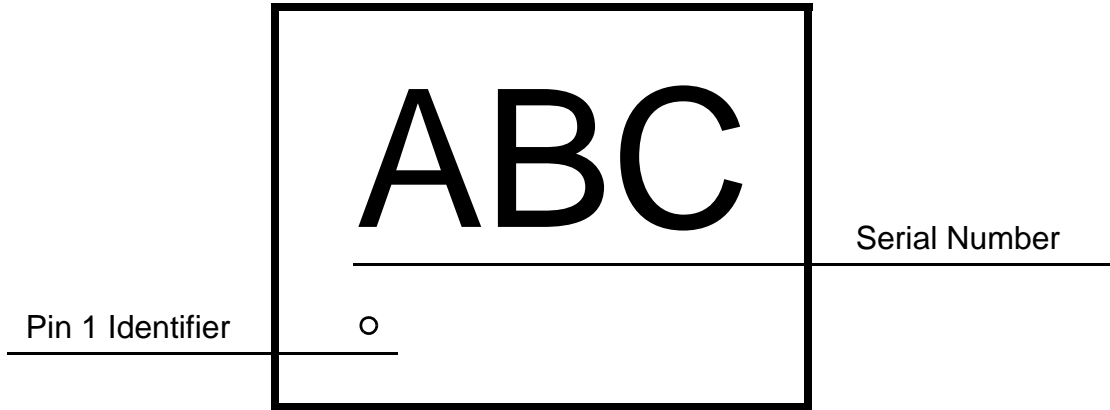



### Package Drawing and Dimensions

8 Lead STDFN Package 1.0 x 1.6 mm (Fused Lead)

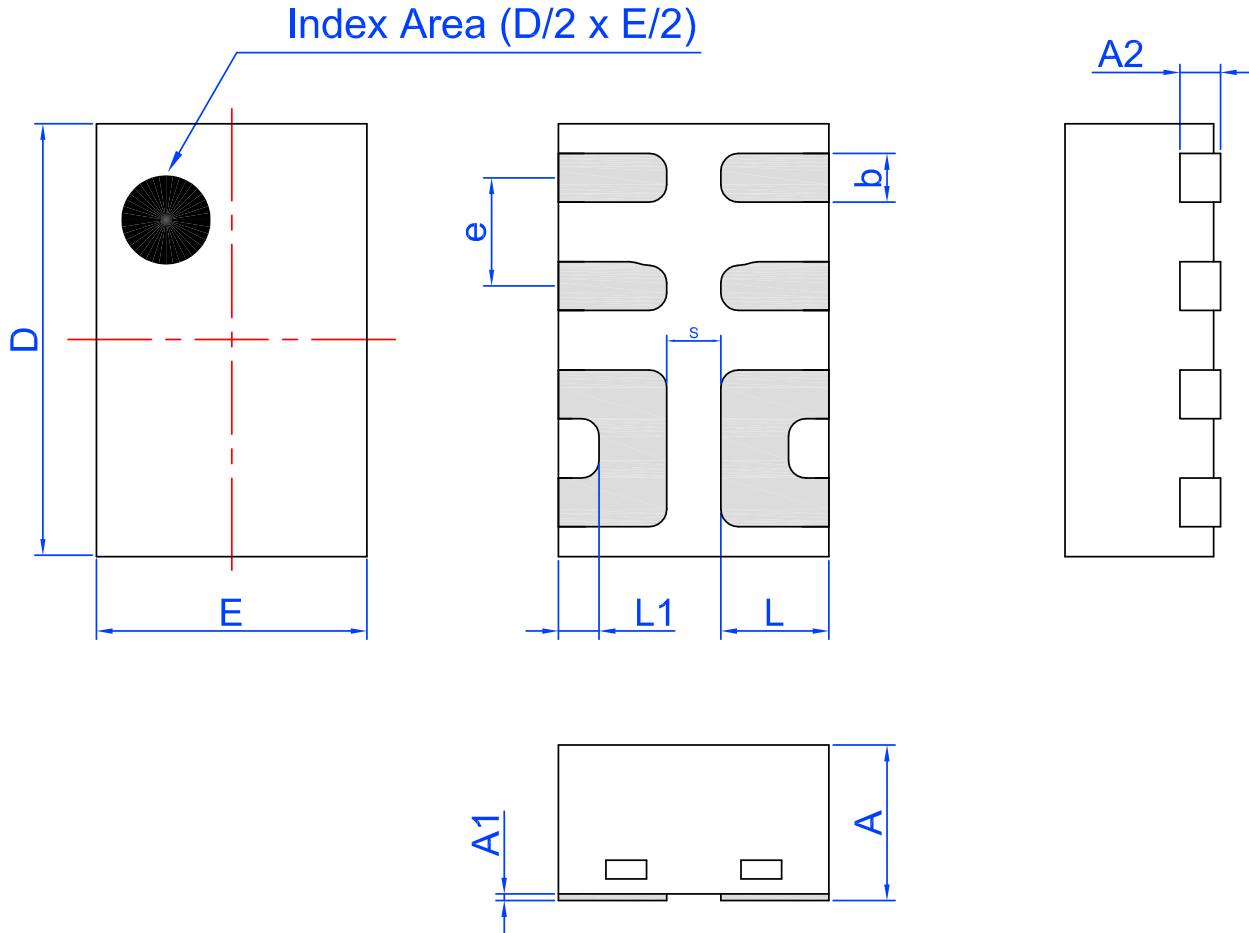

Unit: mm

Symbol	Min	Nom.	Max	Symbol	Min	Nom.	Max
A	0.50	0.55	0.60	D	1.55	1.60	1.65
A1	0.005	-	0.060	E	0.95	1.00	1.05
A2	0.10	0.15	0.20	L	0.35	0.40	0.45
b	0.13	0.18	0.23	L1	0.10	0.15	0.20
e	0.40 BSC			S	0.2 REF		



**Tape and Reel Specifications**

Package Type	# of Pins	Nominal Package Size [mm]	Max Units		Reel & Hub Size [mm]	Leader (min)		Trailer (min)		Tape Width [mm]	Part Pitch [mm]
			per Reel	per Box		Pockets	Length [mm]	Pockets	Length [mm]		
STDFN 8L 1x1.6mm 0.4P FC Green	8	1.0 x 1.6 x 0.55	3,000	3,000	178 / 60	100	400	100	400	8	4

**Carrier Tape Drawing and Dimensions**

Package Type	Pocket BTM Length	Pocket BTM Width	Pocket Depth	Index Hole Pitch	Pocket Pitch	Index Hole Diameter	Index Hole to Tape Edge	Index Hole to Pocket Center	Tape Width
	A0	B0	K0	P0	P1	D0	E	F	W
STDFN 8L 1x1.6mm 0.4P FC Green	1.12	1.72	0.7	4	4	1.55	1.75	3.5	8

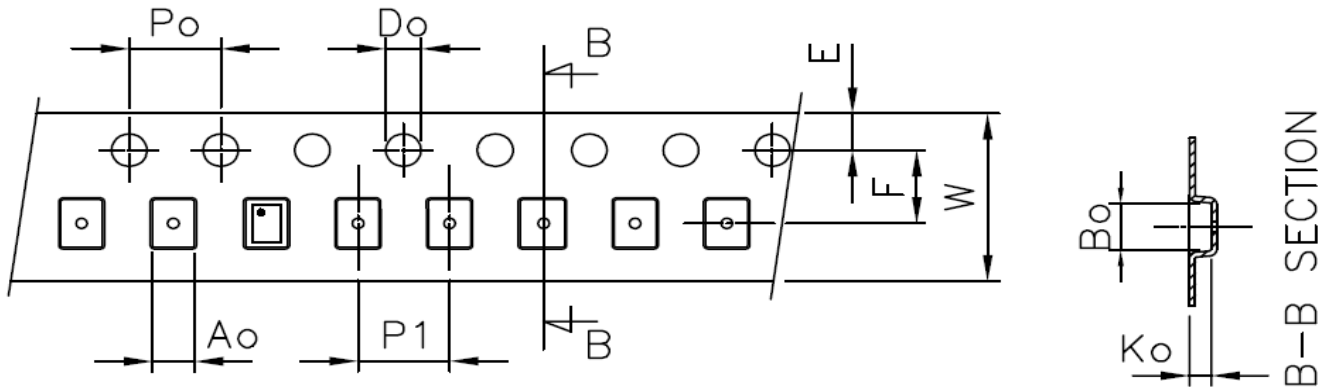

**Recommended Reflow Soldering Profile**

Please see IPC/JEDEC J-STD-020: latest revision for reflow profile based on package volume of 0.88 mm<sup>3</sup> (nominal). More information can be found at [www.jedec.org](http://www.jedec.org).



---

**Revision History**

Date	Version	Change
11/5/2015	1.01	Updated VD min to 0.85 V
9/14/2015	1.00	Production Release



## X-ON Electronics

Largest Supplier of Electrical and Electronic Components

*Click to view similar products for [Power Switch ICs - Power Distribution](#) category:*

*Click to view products by [Silego](#) manufacturer:*

Other Similar products are found below :

[TCK111G,LF\(S\)](#) [FPF1018](#) [DS1222](#) [TCK2065G,LF](#) [SZNCP3712ASNT3G](#) [MIC2033-05BYMT-T5](#) [MIC2033-12AYMT-T5](#) [MIC2033-05BYM6-T5](#) [SLG5NT1437VTR](#) [SZNCP3712ASNT1G](#) [DML1008LDS-7](#) [KTS1670EDA-TR](#) [KTS1640QGDV-TR](#) [KTS1641QGDV-TR](#) [NCV459MNWTBG](#) [FPF2260ATMX](#) [U6513A](#) [U6119S](#) [MIC2012YM-TR](#) [MAX14919ATP+](#) [MC33882PEP](#) [TPS2021IDRQ1](#) [TPS2104DBVR](#) [MIC2098-1YMT-TR](#) [MIC94062YMT TR](#) [MP6231DN-LF](#) [MIC2075-2YM](#) [MIC2095-2YMT-TR](#) [MIC94068YML-TR](#) [SIP32461DB-T2-GE1](#) [NCP335FCT2G](#) [TCK105G,LF\(S\)](#) [AP2151DSG-13](#) [MIC94094YC6-TR](#) [MIC94064YC6-TR](#) [MIC2505-1YM](#) [MIC94305YMT-TR](#) [MIC94081YFT-TR](#) [MIC94042YFL-TR](#) [MIC94041YFL-TR](#) [MIC2005-1.2YM6-TR](#) [TPS2032QDRQ1](#) [SIP32510DT-T1-GE3](#) [NCP333FCT2G](#) [NCP331SNT1G](#) [TPS2092DR](#) [TPS2063DR](#) [TPS2042P](#) [MIC2008YML-TR](#) [MIC2040-1YMM](#)