



SILEGO

Ultra-small 2-Channel 45 mΩ/2 A Power Switch with Reverse-Current Blocking

SLG59M1638V

General Description

The SLG59M1638V is a dual-channel, 45 mΩ PMOS power switch designed to switch 1.5 to 5 V power rails up to 2A in each channel. When either channel is enabled, reverse-current protection will quickly open the switch in the event of a reverse-voltage condition is detected (a $V_{OUT} > V_{IN} + 50$ mV condition opens the switch). In the event that the channel's V_{IN} voltage is too low, the power switch also contains an internal UVLO threshold monitor to keep or to turn the switch OFF. For fast load turnoff when either switch is disabled ($ONx = \text{HIGH-to-LOW}$), each channel has its own fast discharge transistor that connects an internal 150 Ω $R_{DS(ON)}$ transistor to ground. Each power switch is independently controlled via its own low-voltage compatible CMOS input.

Designed to operate over a -40°C to 85°C range, the SLG59M1638V is available in a RoHS-compliant, ultra-small 1.6 x 1.0 mm STDFN package.

Features

- Integrated 2-Channel PMOS Power Switch
- 2 A Maximum Continuous Switch Current per Channel
- Low $R_{DS(ON)}$:
 - 45 mΩ at $V_{IN} = 5$ V
 - 60 mΩ at $V_{IN} = 2.5$ V
 - 80 mΩ at $V_{IN} = 1.5$ V
- Operating Voltage: 1.5 V to 5.5 V
- Reverse-current/voltage Protection
- Fast Output Discharge
- Low-voltage CMOS Logic Compatible Switch Control
- Operating temperature range: -40°C to 85°C
- Pb-Free / Halogen-Free / RoHS compliant packaging

Pin Configuration

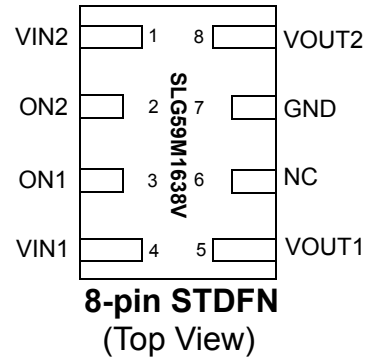

Applications

- Power-Rail Switching:
 - Notebook/Laptop/Tablet PCs
 - Smartphones/Wireless Handsets
 - High-definition Digital Cameras
 - Set-top Boxes
- Point of Sales Pins
- GPS Navigation Devices

Block Diagram

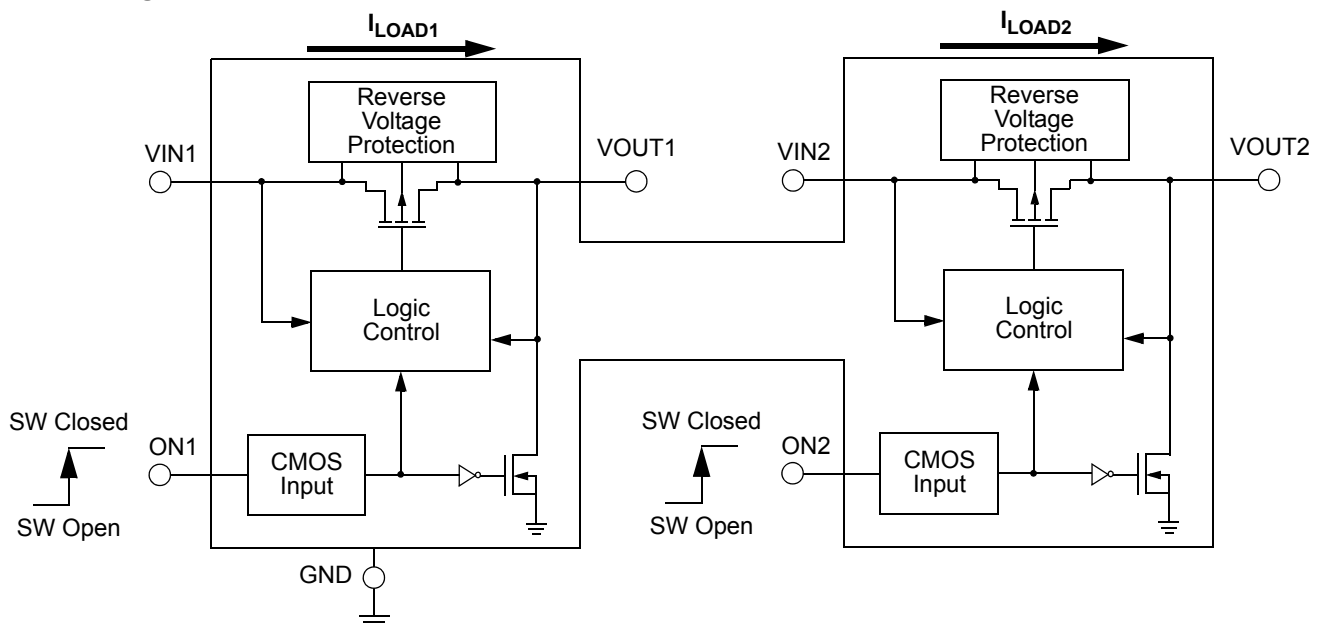



Pin Description

Pin #	Pin Name	Type	Pin Description
1	VIN2	MOSFET	Input and source terminal of MOSFET #2. Bypass the VIN2 pin to GND with a 1 μ F (or larger), low-ESR capacitor.
2	ON2	Input	ON2 turns Channel 2 MOSFET ON and is a low logic-level CMOS input with $V_{IL} < 0.3$ V and $V_{IH} > 1$ V. As the ON2 input circuit does not have an internal pull-down resistor, connect ON2 pin directly to a GPIO controller – do not allow this pin to be open circuited.
3	ON1	Input	ON1 turns Channel 1 MOSFET ON and is a low-logic level CMOS input with $V_{IL} < 0.3$ V and $V_{IH} > 1$ V. As the ON1 input circuit does not have an internal pull-down resistor, connect ON1 pin directly to a GPIO controller – do not allow this pin to be open circuited.
4	VIN1	MOSFET	Input and source terminal of MOSFET #1. Bypass the VIN1 pin to GND with a 1 μ F (or larger), low-ESR capacitor.
5	VOUT1	MOSFET	Output and drain terminal of MOSFET #1.
6	NC	No Connect	No connection. Do not make connection to any other pin - leave Pin 6 as an open circuit.
7	GND	GND	Ground connection. Connect this pin to system analog or power ground plane.
8	VOUT2	MOSFET	Output and drain terminal of MOSFET #2.

Ordering Information

Part Number	Type	Production Flow
SLG59M1638V	STDFN	Industrial, -40 °C to 85 °C
SLG59M1638VTR	STDFN (Tape and Reel)	Industrial, -40 °C to 85 °C



Absolute Maximum Ratings

Parameter	Description	Conditions	Min.	Typ.	Max.	Unit
V_{IN}	Power Supply		0.3	--	6	V
T_S	Storage Temperature		-65	--	150	°C
ESD _{HBM}	ESD Protection	Human Body Model	2000	--	--	V
ESD _{CDM}	ESD Protection	Charged Device Model	1000	--	--	V
MSL	Moisture Sensitivity Level		1			
θ_{JA}	Thermal Resistance	1.0 x 1.6 mm 8L STDFN	--	82	--	°C/W
$T_{J,MAX}$	Maximum Junction Temperature		--	150	--	°C
MOSFET IDS _{CONT}	Continuous Current from VIN to VOUT	Each channel, $T_J < 150^\circ\text{C}$	--	--	2	A
MOSFET IDS _{PK}	Peak Current from Drain to Source	Maximum pulsed switch current, pulse width < 1 ms, 1% duty cycle	--	--	2.5	A

Note: Stresses greater than those listed under "Absolute Maximum Ratings" may cause permanent damage to the device. This is a stress rating only and functional operation of the device at these or any other conditions above those indicated in the operational sections of this specification is not implied. Exposure to absolute maximum rating conditions for extended periods may affect reliability.

Electrical Characteristics

$1.5\text{V} \leq V_{IN[1,2]} \leq 5.5\text{V}$; $C_{IN} = 1\mu\text{F}$, $T_A = -40^\circ\text{C}$ to 85°C , unless otherwise noted.

Typical values are at $T_A = 25^\circ\text{C}$ (unless otherwise stated)

Parameter	Description	Conditions	Min.	Typ.	Max.	Unit
$V_{IN[1,2]}$	Switch Input Voltage		1.5	--	5.5	V
$V_{IN(UVLO)}$	V_{IN} Undervoltage Lockout Threshold	$V_{IN} \uparrow$, $V_{ON} = 0\text{V}$, $I_{OUT} = -100\text{mA}$	--	--	1.2	V
		$V_{IN} \downarrow$, $V_{ON} = 0\text{V}$, $R_{LOAD} = 10\Omega$	0.5	--	--	V
I_{IN}	Quiescent Supply Current, Both Channels	$V_{IN} = 5.25\text{V}$, $V_{ON} = V_{IN}$, $I_{OUT} = 0\text{mA}$	--	3.5	5.3	μA
		$V_{IN} = 1.5\text{V}$, $V_{ON} = V_{IN}$, $I_{OUT} = 0\text{mA}$	--	2.5	4	μA
$I_{IN(OFF)}$	OFF Mode Supply Current, Both Channels	$V_{IN} = 5.25\text{V}$, $V_{ON} = \text{LOW}$, $R_{LOAD} = 1\text{M}\Omega$	--	1	2	μA
		$V_{IN} = 1.5\text{V}$, $V_{ON} = \text{LOW}$, $R_{LOAD} = 1\text{M}\Omega$	--	0.4	1	μA
RDS _{ON}	Static Drain to Source ON Resistance	$T_A = 25^\circ\text{C}$, $V_{IN} = 5.0\text{V}$, $I_{LOAD} = -200\text{mA}$	--	45	55	m Ω
		$T_A = 25^\circ\text{C}$, $V_{IN} = 2.5\text{V}$, $I_{LOAD} = -200\text{mA}$	--	60	72	m Ω
		$T_A = 25^\circ\text{C}$, $V_{IN} = 1.5\text{V}$, $I_{LOAD} = -200\text{mA}$	--	80	96	m Ω
$V_{REVERSE}$	Reverse-current Voltage Threshold		--	50	--	mV
$I_{REVERSE}$	Reverse-current Leakage Current after Reverse Current Event	$V_{OUT} - V_{IN} > V_{REVERSE}$; $T_A = 25^\circ\text{C}$	--	0.6	--	μA
$V_{ON[1,2]}$	ON Pin Voltage Range		0	--	V_{IN}	V
$I_{ON(Leakage)}$	ON Pin Leakage Current	$1.4\text{V} \leq V_{ON} \leq 5.25\text{V}$ or $V_{ON} = \text{GND}$	--	--	1	μA
ON_ V_{IH}	ON Pin Input High Voltage		1	--	V_{DD}	V
ON_ V_{IL}	ON Pin Input Low Voltage		-0.3	0	0.3	V
ON _{HYS}	ON Hysteresis		--	60	--	mV



Electrical Characteristics (continued)

1.5V ≤ V_{IN[1,2]} ≤ 5.5V; C_{IN} = 1μF, T_A = -40 °C to 85 °C, unless otherwise noted.
 Typical values are at T_A = 25°C (unless otherwise stated)

Parameter	Description	Conditions	Min.	Typ.	Max.	Unit
RDSCHRG	Output Discharge Resistance	V _{IN} = 5 V, V _{OUT} = 0.4 V	0.1	0.15	0.2	kΩ
		V _{IN} = 1.5 V, V _{OUT} = 0.4 V	0.6	1	1.4	kΩ
T _{REV}	Reverse-current Detect Response Delay	V _{IN} = 5 V	--	10	--	μs
T _{REARM}	Reverse Detect Rearm Time		--	200	--	μs
T _{ON_Delay}	ON[1,2] Delay Time	50% ON to 50% V _{OUTx} ↑; T _A = 25°C, V _{INx} = 5 V; R _{LOAD} = 10 Ω, C _{LOAD} = 0.1 μF	145	210	315	μs
		50% V _{IN} to 50% V _{OUTx} ↑; T _A = 25°C, V _{INx} = 1.5 V; R _{LOAD} = 10 Ω, C _{LOAD} = 0.1 μF	125	180	270	μs
T _{VOUT(R)}	V _{OUT} [1,2] Rise Time	10% to 90% V _{OUTx} ↑; T _A = 25°C, V _{INx} = 5 V; R _{LOAD} = 10 Ω, C _{LOAD} = 0.1 μF	100	145	196	μs
		10% to 90% V _{OUTx} ↑; T _A = 25°C, V _{INx} = 1.5 V; R _{LOAD} = 10 Ω, C _{LOAD} = 0.1 μF	50	73	100	μs
T _{VOUT(F)}	V _{OUT} [1,2] Fall Time	90% to 10% V _{OUTx} ↓; T _A = 25°C, V _{INx} = 5 V; R _{LOAD} = 10 Ω, C _{LOAD} = 0.1 μF	--	--	6	μs
		90% to 10% V _{OUTx} ↓; T _A = 25°C, V _{INx} = 1.5 V; R _{LOAD} = 10 Ω, C _{LOAD} = 0.1 μF	--	--	6	μs
T _{OFF_Delay}	OFF Delay Time	50% ON to 50% V _{OUT} ↓; T _A = 25°C, V _{IN} = 5V; R _{LOAD} = 10Ω, C _{LOAD} = 0.1μF	--	3.1	5.5	μs
		50% ON to 50% V _{OUT} ↓; T _A = 25°C, V _{IN} = 1.5 V; R _{LOAD} = 10 Ω, C _{LOAD} = 0.1 μF	--	4.8	6.5	μs

T_{Total_ON}, T_{ON_Delay} and Slew Rate Measurement

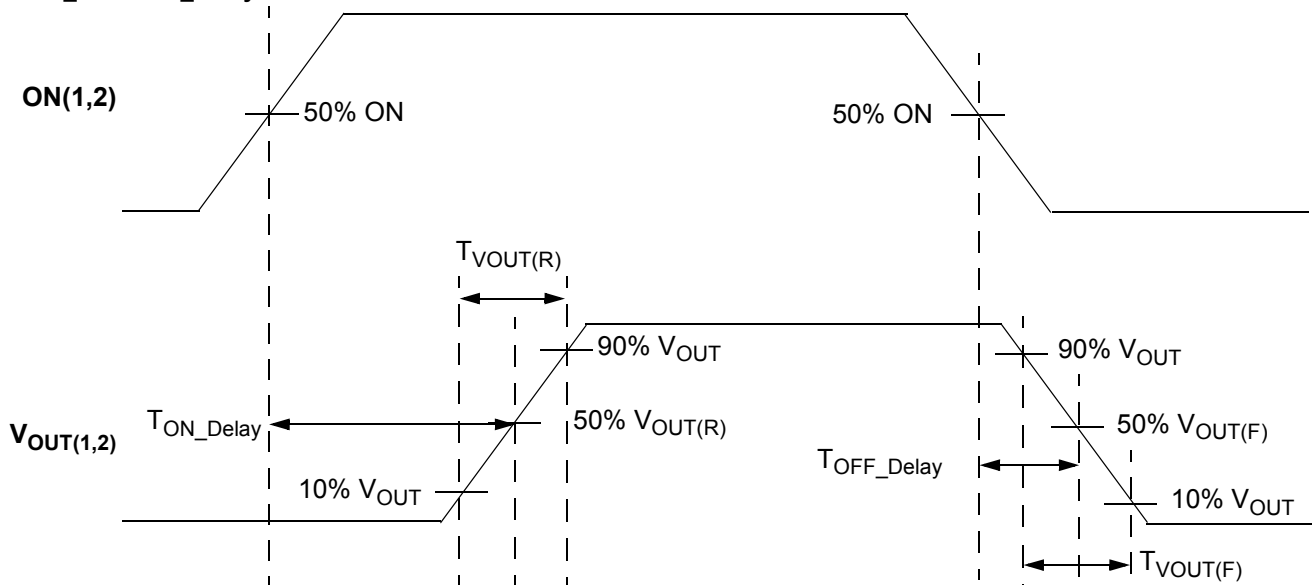



RDS_{ON} vs. V_{IN[1,2]} and Temperature

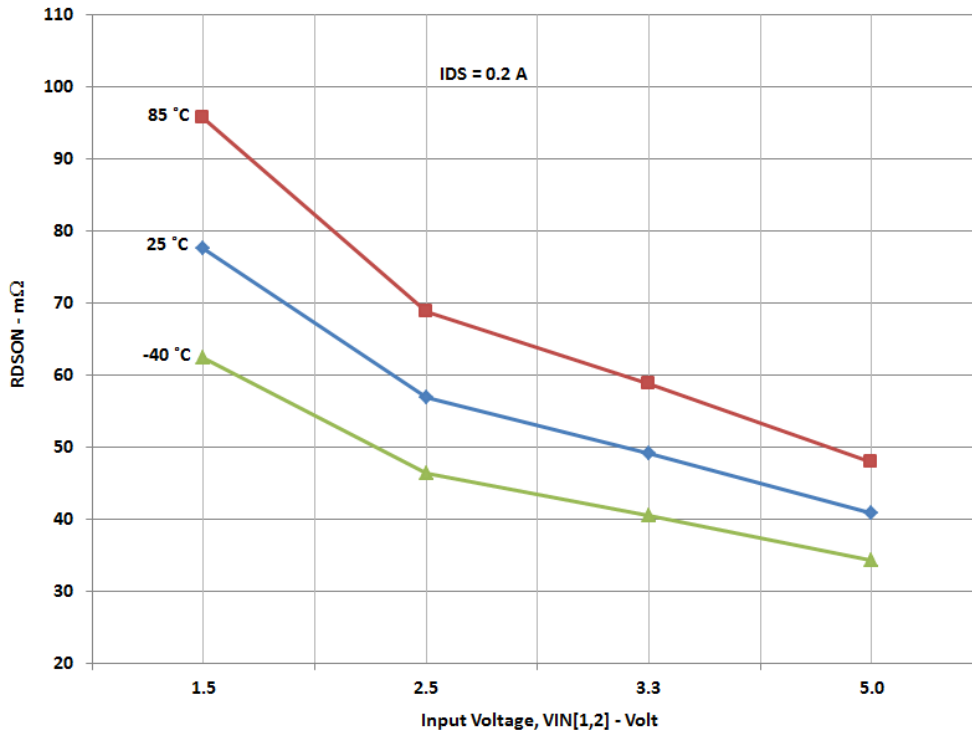

RDS_{ON} vs. Temperature and V_{IN[1,2]}

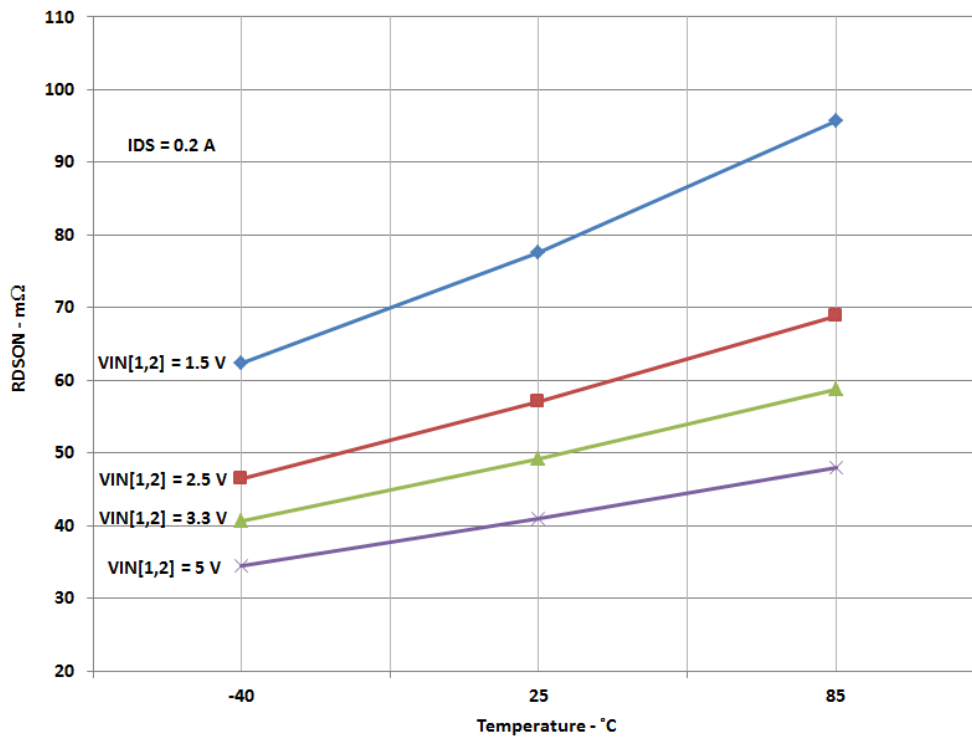



V_{IN[1,2]} Inrush Current Details

When either channel of the SLG59M1638V is enabled with ON[1,2] ↑, the power switch closes to charge the V_{OUT[1,2]} output capacitor to V_{IN[1,2]}. The charging current drawn from V_{IN[1,2]} is commonly referred to as “VIN inrush current” and can cause the input power source to collapse if the VIN inrush current is too high.

Since the V_{OUT[1,2]} rise time of the SLG59M1638V is fixed, V_{IN[1,2]} inrush current is then a function of the output capacitance at V_{OUT[1,2]}. The expression relating V_{IN[1,2]} inrush current, the SLG59M1638V V_{OUT[1,2]} rise time, and C_{LOAD[1,2]} is:

$$V_{IN[1,2]} \text{ Inrush Current} = C_{LOAD[1,2]} \times \frac{\Delta V_{OUT[1,2]}}{V_{OUT[1,2]} \text{ Rise Time}}$$

where in this expression Δ V_{OUT[1,2]} is equivalent to 0.8 x V_{IN[1,2]} if the initial SLG59M1638V’s output voltages are zero.

In the table below are examples of V_{IN[1,2]} inrush currents assuming zero initial charge on C_{LOAD[1,2]} as a function of V_{IN[1,2]}.

V _{IN[1,2]}	V _{OUT[1,2]} Rise Time	C _{LOAD[1,2]}	Inrush Current
1.5 V	73 μs	0.1 μF	1.6 mA
5 V	145 μs	0.1 μF	2.8 mA

Since the relationship is linear and if C_{LOAD[1,2]} were increased to 1 μF, then the V_{IN[1,2]} inrush currents would be 10x higher in either example. If a large C_{LOAD[1,2]} capacitor is required in the application and depending upon the strength of the input power source, it may very well be necessary to increase the C_{IN}-to-C_{LOAD} ratio to minimize V_{IN[1,2]} droop during turn-on.

For other V_{OUT[1,2]} rise time options, please contact Silego for additional information.

Power Dissipation

The junction temperature of the SLG59M1638V depends on factors such as board layout, ambient temperature, external air flow over the package, load current, and the RDS_{ON}-generated voltage drop across each power MOSFET. While the primary contributor to the increase in the junction temperature of the SLG59M1638V is the power dissipation of its power MOSFETs, its power dissipation and the junction temperature in nominal operating mode can be calculated using the following equations:

$$PD_{TOTAL} = (RDS_{ON1} \times I_{DS1}^2) + (RDS_{ON2} \times I_{DS2}^2)$$

where:

PD_{TOTAL} = Total package power dissipation, in Watts (W)

RDS_{ON[1,2]} = Channel 1 and Channel 2 Power MOSFET ON resistance, in Ohms (Ω), respectively

I_{DS[1,2]} = Channel 1 and Channel 2 Output current, in Amps (A), respectively

and

$$T_J = PD_{TOTAL} \times \theta_{JA} + T_A$$

where:

T_J = Die junction temperature, in Celsius degrees (°C)

θ_{JA} = Package thermal resistance, in Celsius degrees per Watt (°C/W) – highly dependent on pcb layout

T_A = Ambient temperature, in Celsius degrees (°C)



Power Dissipation (continued)

In nominal operating mode, the SLG59M1638V's power dissipation can also be calculated by taking into account the voltage drop across each switch ($V_{INx}-V_{OUTx}$) and the magnitude of that channel's output current (I_{DSx}):

$$PD_{TOTAL} = [(V_{IN1}-V_{OUT1}) \times I_{DS1}] + [(V_{IN2}-V_{OUT2}) \times I_{DS2}] \text{ or}$$

$$PD_{TOTAL} = [(V_{IN1} - (R_{LOAD1} \times I_{DS1})) \times I_{OUT1}] + [(V_{IN2} - (R_{LOAD2} \times I_{DS2})) \times I_{DS2}]$$

where:

PD_{TOTAL} = Total package power dissipation, in Watts (W)

$V_{IN[1,2]}$ = Channel 1 and Channel 2 Input Voltage, in Volts (V), respectively

$R_{LOAD[1,2]}$ = Channel 1 and Channel 2 Output Load Resistance, in Ohms (Ω), respectively

$I_{DS[1,2]}$ = Channel 1 and Channel 2 output current, in Amps (A), respectively

$V_{OUT[1,2]}$ = Channel 1 and Channel 2 output voltage, or $R_{LOAD[1,2]} \times I_{OUT[1,2]}$, respectively

Power Dissipation Derating Curve

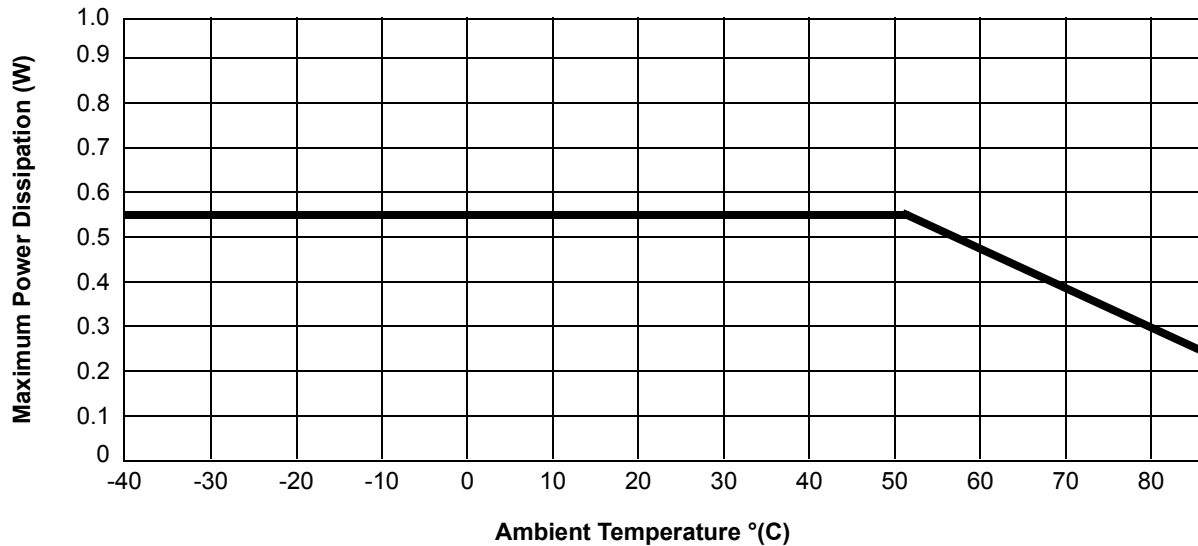

Note: Each V_{IN} , V_{OUT} = 1 in² 1.2 oz. copper on FR4



SLG59M1638V Layout Suggestion

 Exposed Pad
(PKG face down)

 Recommended Land Pattern
(PKG face down)

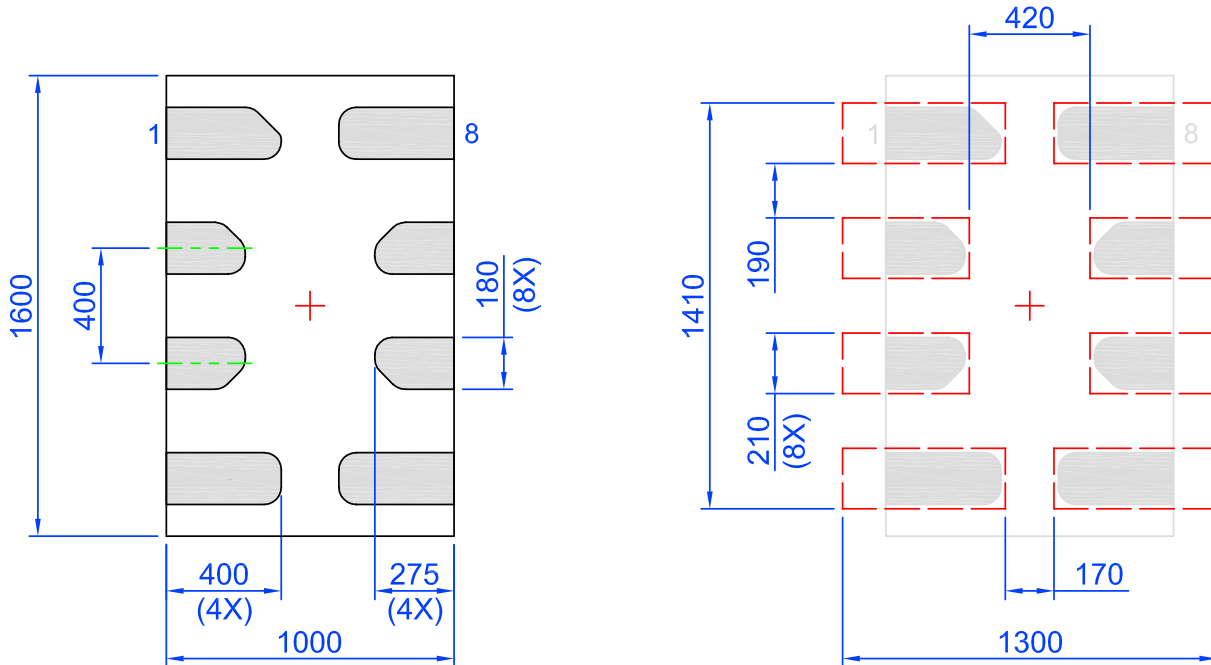

Note: All dimensions shown in micrometers (μm)

Package Top Marking System Definition

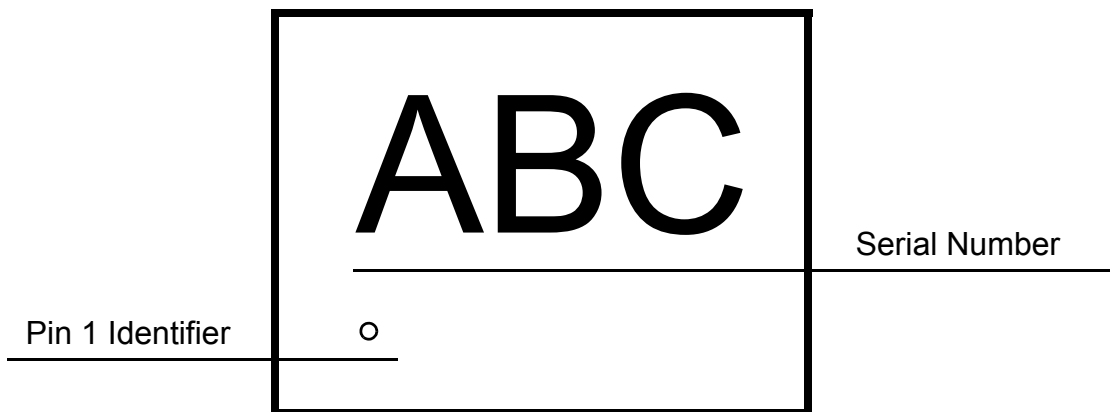

ABC - 3 alphanumeric Part Serial Number
where A, B, or C can be A-Z and 0-9



Package Drawing and Dimensions

8 Lead STDFN Package 1.0 x 1.6 mm

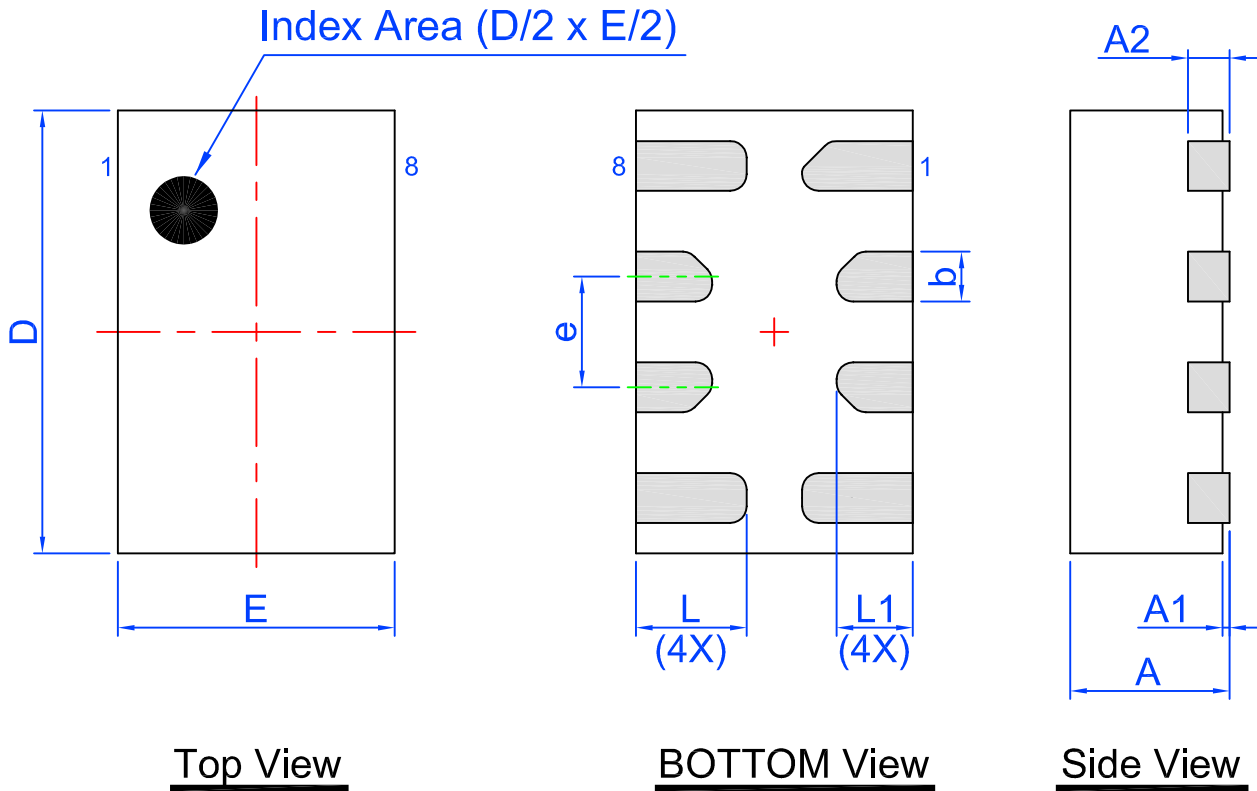

Unit: mm

Symbol	Min	Nom.	Max	Symbol	Min	Nom.	Max
A	0.50	0.55	0.60	D	1.55	1.60	1.65
A1	0.005	-	0.050	E	0.95	1.00	1.05
A2	0.10	0.15	0.20	L	0.35	0.40	0.45
b	0.13	0.18	0.23	L1	0.225	0.275	0.325
e	0.40 BSC						



Revision History

Date	Version	Change
8/28/2017	1.02	Updated Inrush Current Details Fixed typos
4/13/2017	1.01	Fixed Reverse Voltage Detection equation
2/23/2017	1.00	Production Release

X-ON Electronics

Largest Supplier of Electrical and Electronic Components

Click to view similar products for [Power Switch ICs - Power Distribution](#) category:

Click to view products by [Silego](#) manufacturer:

Other Similar products are found below :

[TCK111G,LF\(S\)](#) [FPF1018](#) [DS1222](#) [TCK2065G,LF](#) [SZNCP3712ASNT3G](#) [MIC2033-05BYMT-T5](#) [MIC2033-12AYMT-T5](#) [MIC2033-05BYM6-T5](#) [SLG5NT1437VTR](#) [SZNCP3712ASNT1G](#) [NCV330MUTBG](#) [DML1008LDS-7](#) [KTS1670EDA-TR](#) [KTS1640QGDV-TR](#) [KTS1641QGDV-TR](#) [NCV459MNWTBG](#) [FPF2260ATMX](#) [U6513A](#) [U6119S](#) [NCP45780IMN24RTWG](#) [MAX14919ATP+](#) [MC33882PEP](#) [TPS2021HDRQ1](#) [TPS2104DBVR](#) [MIC2098-1YMT-TR](#) [MIC94062YMT TR](#) [MP6231DN-LF](#) [MIC2075-2YM](#) [MIC2095-2YMT-TR](#) [MIC94068YML-TR](#) [SIP32461DB-T2-GE1](#) [NCP335FCT2G](#) [FPF2701MX](#) [TCK105G,LF\(S\)](#) [AP2151DSG-13](#) [MIC94094YC6-TR](#) [MIC94064YC6-TR](#) [MIC2505-1YM](#) [MIC94042YFL-TR](#) [MIC94041YFL-TR](#) [MIC2005-1.2YM6-TR](#) [TPS2032QDRQ1](#) [SIP32510DT-T1-GE3](#) [NCP333FCT2G](#) [NCP331SNT1G](#) [TPS2092DR](#) [TPS2063DR](#) [TPS2042P](#) [MIC2008YML-TR](#) [MIC2040-1YMM](#)