



## An Ultra-small 1.6 mm<sup>2</sup>, 17 mΩ, 2.5 A, 125°C-Rated Internally-protected Integrated Power Switch with Discharge

### General Description

The SLG59M1658V is a high performance 17 mΩ, 2.5 A single-channel nFET integrated power switch which can operate with a 2.5 V to 5.5 V V<sub>DD</sub> supply to switch power rails from as low as 0.9 V up to the supply voltage. The SLG59M1658V incorporates two-level overload current protection, thermal shutdown protection, fast output voltage discharge, and in-rush current control which can easily be adjusted by a small external capacitor.

Using a proprietary MOSFET design, the SLG59M1658V achieves a stable 17 mΩ RDS<sub>ON</sub> across a wide input voltage range. In addition, the SLG59M1658V's package also exhibits low thermal resistance for high-current operation using Silego's proprietary CuFET technology.

Fully specified over the -40 °C to 125 °C temperature range, the SLG59M1658V is packaged in a space-efficient, low thermal resistance, RoHS-compliant 1.0 mm x 1.6 mm STDFN package.

### Features

- 1.0 x 1.6 x 0.55 mm STDFN 8L package (2 fused pins for drain and 2 fused pins for source)
- Logic level ON pin capable of supporting 0.85 V CMOS Logic
- User selectable ramp rate with external capacitor
- 17 mΩ RDS<sub>ON</sub> while supporting 2.5 A
- Discharges load when off
- Two Over Current Protection Modes
  - Short Circuit Current Limit
  - Active Current Limit
- Over Temperature Protection
- Pb-Free / Halogen-Free / RoHS compliant
- Operating Temperature: -40 °C to 125°C
- Operating Voltage: 2.5 V to 5.5 V

### Pin Configuration

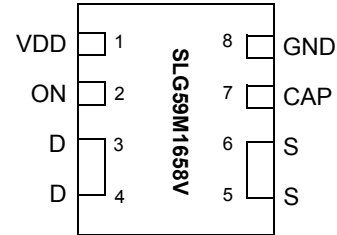

8-pin STDFN (Top View)

### Applications

- Notebook Power Rail Switching
- Tablet Power Rail Switching
- Smartphone Power Rail Switching

### Block Diagram

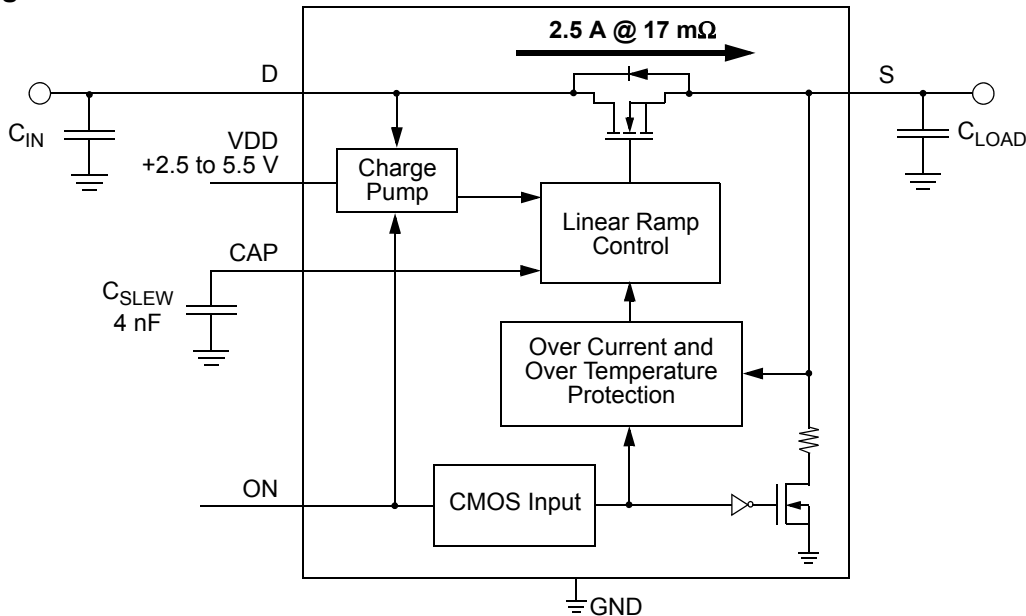



### Pin Description

Pin #	Pin Name	Type	Pin Description
1	VDD	PWR	With an internal 1.8 V UVLO threshold, VDD supplies the power for the operation of the power switch and internal control circuitry. Bypass the VDD pin to GND with a 0.1 $\mu$ F (or larger) capacitor.
2	ON	Input	A low-to-high transition on this pin initiates the operation of the SLG59M1658V's state machine. ON is a CMOS input with $V_{IL} < 0.25$ V and $V_{IH} > 0.85$ V thresholds. While there is an internal pull-down circuit to GND ( $\sim 4$ M $\Omega$ ), connect this pin directly to a general-purpose output (GPO) of a microcontroller, an application processor, or a system controller. Do not allow this pin to be open-circuited.
3, 4	D	MOSFET	Drain terminal connection of the n-channel MOSFET (2 pins fused for $V_D$ ). Connect at least a low-ESR 0.1 $\mu$ F capacitor from this pin to ground. Capacitors used at $V_D$ should be rated at 10 V or higher.
5, 6	S	MOSFET	Source terminal connection of the n-channel MOSFET (2 pins fused for $V_S$ ). Connect a low-ESR capacitor from this pin to ground and consult the Electrical Characteristics table for recommended $C_{LOAD}$ range. Capacitors used at $V_S$ should be rated at 10 V or higher.
7	CAP	Input	A low-ESR, stable dielectric, ceramic surface-mount capacitor connected from CAP pin to GND sets the $V_S$ slew rate and overall turn-on time of the SLG59M1658V. For best performance $C_{SLEW}$ value should be $\geq 1.5$ nF and voltage level should be rated at 10 V or higher.
8	GND	GND	Ground connection. Connect this pin to system analog or power ground plane.

### Ordering Information

Part Number	Type	Production Flow
SLG59M1658V	STDFN 8L	Extended Industrial, -40 °C to 125 °C
SLG59M1658VTR	STDFN 8L (Tape and Reel)	Extended Industrial, -40 °C to 125 °C



## Absolute Maximum Ratings

Parameter	Description	Conditions	Min.	Typ.	Max.	Unit
V <sub>DD</sub>	Power Supply		--	--	7	V
V <sub>D</sub> to GND	Power Switch Input Voltage to GND		-0.3	--	7	V
V <sub>S</sub> to GND	Power Switch Output Voltage to GND		-0.3	--	V <sub>D</sub>	V
ON and CAP to GND	ON and CAP Pin Voltages to GND		-0.3	--	7	V
T <sub>S</sub>	Storage Temperature		-65	--	150	°C
ESD <sub>HBM</sub>	ESD Protection	Human Body Model	2000	--	--	V
ESD <sub>CDM</sub>	ESD Protection	Charged Device Model	1000	--	--	V
MSL	Moisture Sensitivity Level		1			
θ <sub>JA</sub>	Thermal Resistance	1.0 x 1.6 mm, 8L STDFN; Determined using 1 in <sup>2</sup> , 1 oz. copper pads under each VD and VS terminals and FR4 pcb material	--	74	--	°C/W
W <sub>DIS</sub>	Package Power Dissipation		--	--	0.4	W
MOSFET IDS	Max Continuous Switch Current		--	--	2.5	A
MOSFET IDS <sub>PK</sub>	Peak Current from Drain to Source	For no more than 1 ms with 1% duty cycle	--	--	3.5	A

Note: Stresses greater than those listed under "Absolute Maximum Ratings" may cause permanent damage to the device. This is a stress rating only and functional operation of the device at these or any other conditions above those indicated in the operational sections of this specification is not implied. Exposure to absolute maximum rating conditions for extended periods may affect reliability.

## Electrical Characteristics

T<sub>A</sub> = -40 to 125 °C (unless otherwise stated)

Parameter	Description	Conditions	Min.	Typ.	Max.	Unit
V <sub>DD</sub>	Power Supply Voltage	-40 to 125°C	2.5	--	5.5	V
V <sub>DD_UVLO</sub>	V <sub>DD</sub> Undervoltage Lockout Threshold	V <sub>DD</sub> ↑	--	1.8	--	V
I <sub>DD</sub>	Power Supply Current (PIN 1)	when OFF; T <sub>A</sub> = 70 °C; V <sub>S</sub> = 0 V; V <sub>D</sub> = V <sub>DD</sub> = 5.5 V	--	--	1	μA
		when OFF; T <sub>A</sub> = 85 °C; V <sub>S</sub> = 0 V; V <sub>D</sub> = V <sub>DD</sub> = 5.5 V	--	--	1	μA
		when OFF; T <sub>A</sub> = 125 °C; V <sub>S</sub> = 0 V; V <sub>D</sub> = V <sub>DD</sub> = 5.5 V	--	--	1	μA
		when ON, no Load	--	75	100	μA
RDS <sub>ON</sub>	Static Drain to Source ON Resistance	T <sub>A</sub> 25°C @ 100 mA	--	17	20.4	mΩ
		T <sub>A</sub> 85°C @ 100 mA	--	20.5	24	mΩ
		T <sub>A</sub> 125°C @ 100 mA	--	24	28.8	mΩ
V <sub>D</sub>	Drain Voltage		0.9	--	V <sub>DD</sub>	V
I <sub>FET_OFF</sub>	MOSFET OFF Leakage Current	V <sub>D</sub> = V <sub>DD</sub> = 5.5 V; V <sub>S</sub> = 0 V; ON = 0 V; T <sub>A</sub> = 70°C	--	--	1	μA
		V <sub>D</sub> = V <sub>DD</sub> = 5.5 V; V <sub>S</sub> = 0 V; ON = 0 V; T <sub>A</sub> = 85°C	--	--	1	μA
		V <sub>D</sub> = V <sub>DD</sub> = 5.5 V; V <sub>S</sub> = 0 V; ON = 0 V; T <sub>A</sub> = 125°C	--	--	5	μA



### Electrical Characteristics (continued)

T<sub>A</sub> = -40 to 125 °C (unless otherwise stated)

Parameter	Description	Conditions	Min.	Typ.	Max.	Unit
T <sub>ON_Delay</sub>	ON pin Delay Time	50% ON to Ramp Begin	--	200	--	μs
V <sub>S(SR)</sub>	Slew Rate	10% V <sub>S</sub> to 90% V <sub>S</sub>	Configurable <sup>1</sup>			V/ms
		Example: C <sub>SLEW</sub> (PIN 7) = 4 nF, V <sub>DD</sub> = V <sub>D</sub> = 5 V, C <sub>LOAD</sub> = 10 μF, R <sub>LOAD</sub> = 20 Ω	--	3.3	--	V/ms
T <sub>Total_ON</sub>	Total Turn On Time	50% ON to 90% V <sub>S</sub>	Configurable <sup>1</sup>			ms
		Example: C <sub>SLEW</sub> (PIN 7) = 4 nF, V <sub>DD</sub> = V <sub>D</sub> = 5 V, C <sub>LOAD</sub> = 10 μF, R <sub>LOAD</sub> = 20 Ω	--	1.50	--	ms
T <sub>OFF_Delay</sub>	OFF Delay Time	50% ON to V <sub>S</sub> Fall Start, V <sub>DD</sub> = V <sub>D</sub> = 5 V, no C <sub>LOAD</sub> , R <sub>LOAD</sub> = 20 Ω	--	8	--	μs
T <sub>FALL</sub>	V <sub>S</sub> Fall Time	90% V <sub>S</sub> to 10% V <sub>S</sub> , V <sub>DD</sub> = V <sub>D</sub> = 5 V, no C <sub>LOAD</sub> , R <sub>LOAD</sub> = 20 Ω	--	3.3	--	μs
C <sub>LOAD</sub>	Output Load Capacitance	C <sub>LOAD</sub> connected from V <sub>S</sub> to GND	--	--	500	μF
R <sub>DIS</sub>	Discharge Resistance		100	200	300	Ω
ON_V <sub>IH</sub>	High Input Voltage on ON pin		0.85	--	V <sub>DD</sub>	V
ON_V <sub>IL</sub>	Low Input Voltage on ON pin		-0.3	0	0.25	V
I <sub>LIMIT</sub>	Active Current Limit (I <sub>ACL</sub> )	MOSFET will automatically limit current when V <sub>S</sub> > 250 mV	--	4.5	--	A
	Short Circuit Current Limit (I <sub>SCL</sub> )	MOSFET will automatically limit current when V <sub>S</sub> < 250 mV	--	0.5	--	A
THERM <sub>ON</sub>	Thermal shutoff turn-on temperature		--	150	--	°C
THERM <sub>OFF</sub>	Thermal shutoff turn-off temperature		--	130	--	°C
THERM <sub>TIME</sub>	Thermal shutoff time		--	--	1	ms

Notes:

1. Refer to table for configuration details.



### $T_{Total\_ON}$ , $T_{ON\_Delay}$ and Slew Rate Measurement

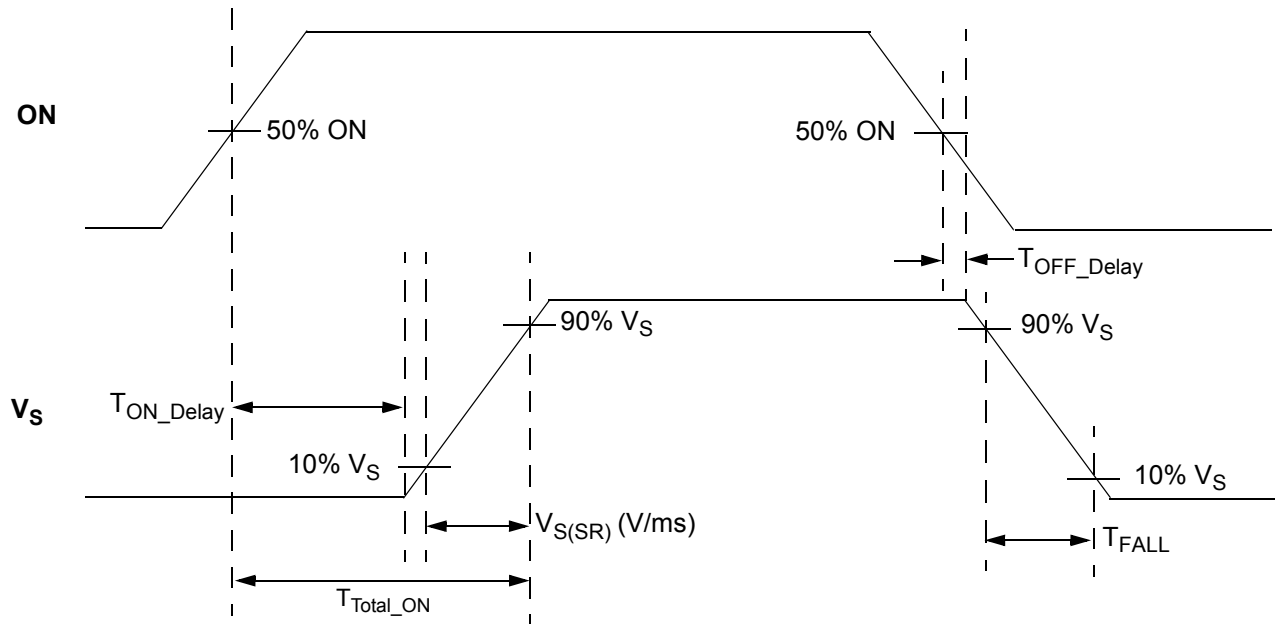

Note: Rise and Fall times of the ON signal are 100 ns



### Typical Performance Characteristics

#### RDS<sub>ON</sub> vs. V<sub>DD</sub>, and Temperature

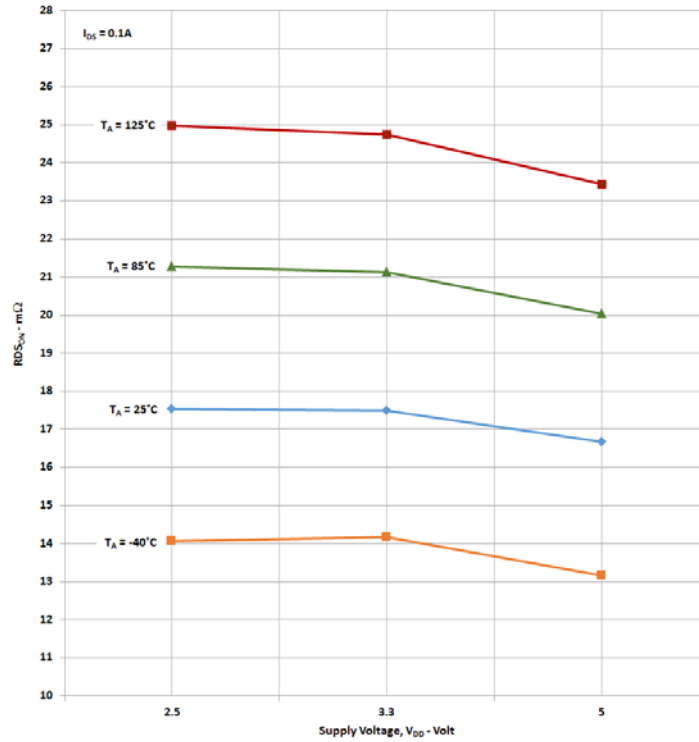

#### RDS<sub>ON</sub> vs. V<sub>D</sub> and V<sub>DD</sub>

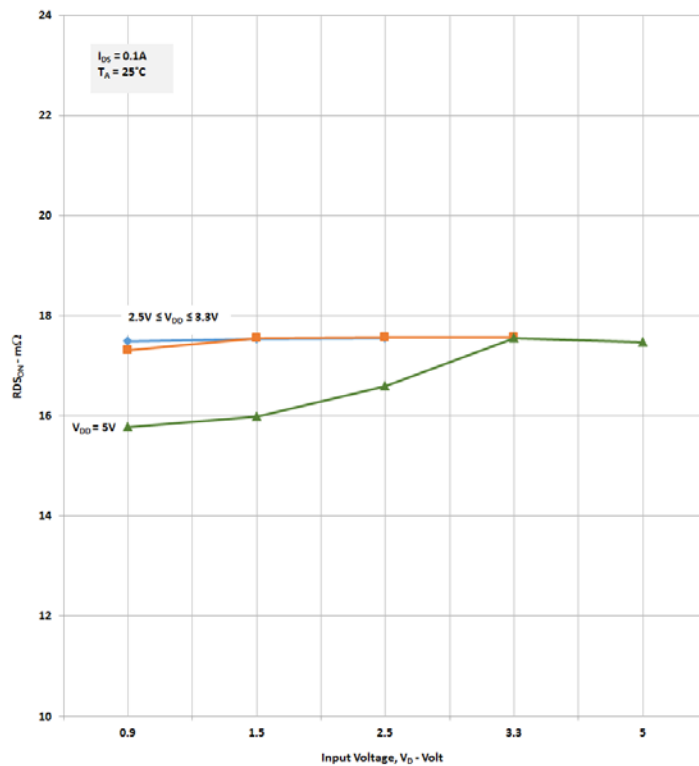



### $V_{S(SR)}$ vs. Temperature, $V_D$ , $V_{DD}$ , and $C_{SLEW}$

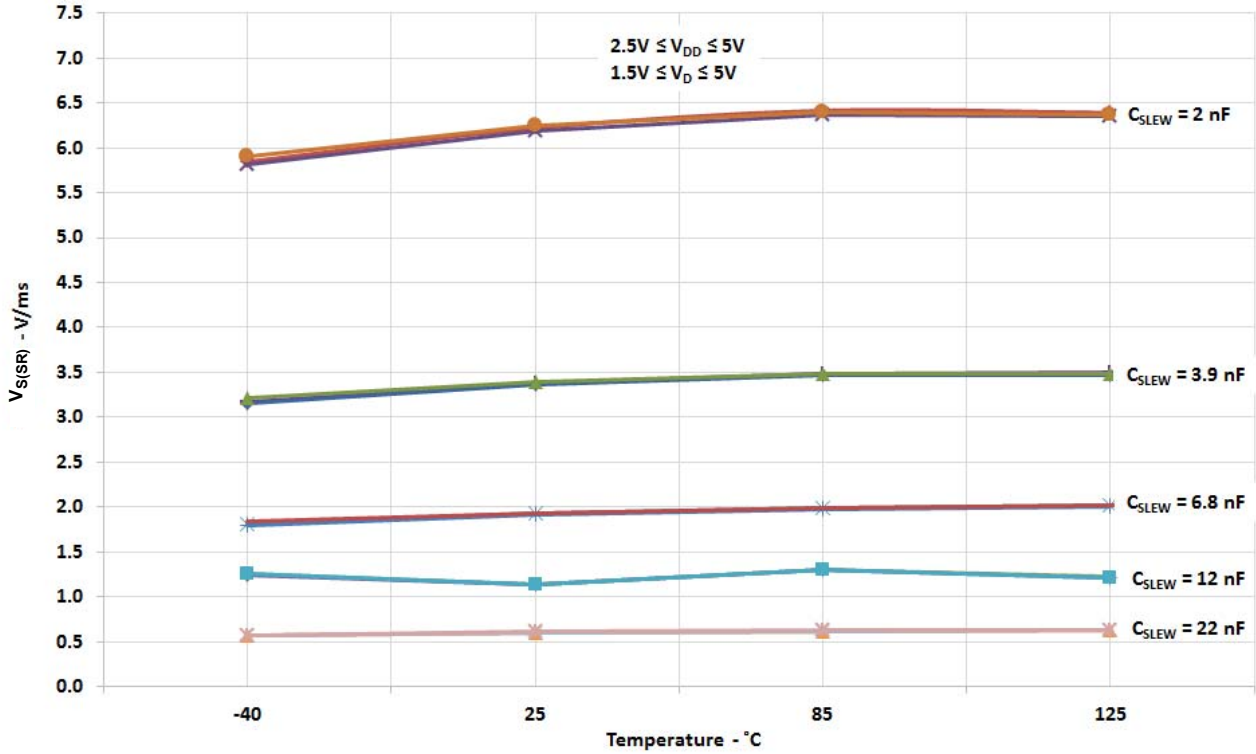

### $T_{Total\ ON}$ vs. $C_{SLEW}$ , $V_D$ , $V_{DD}$ , and Temperature

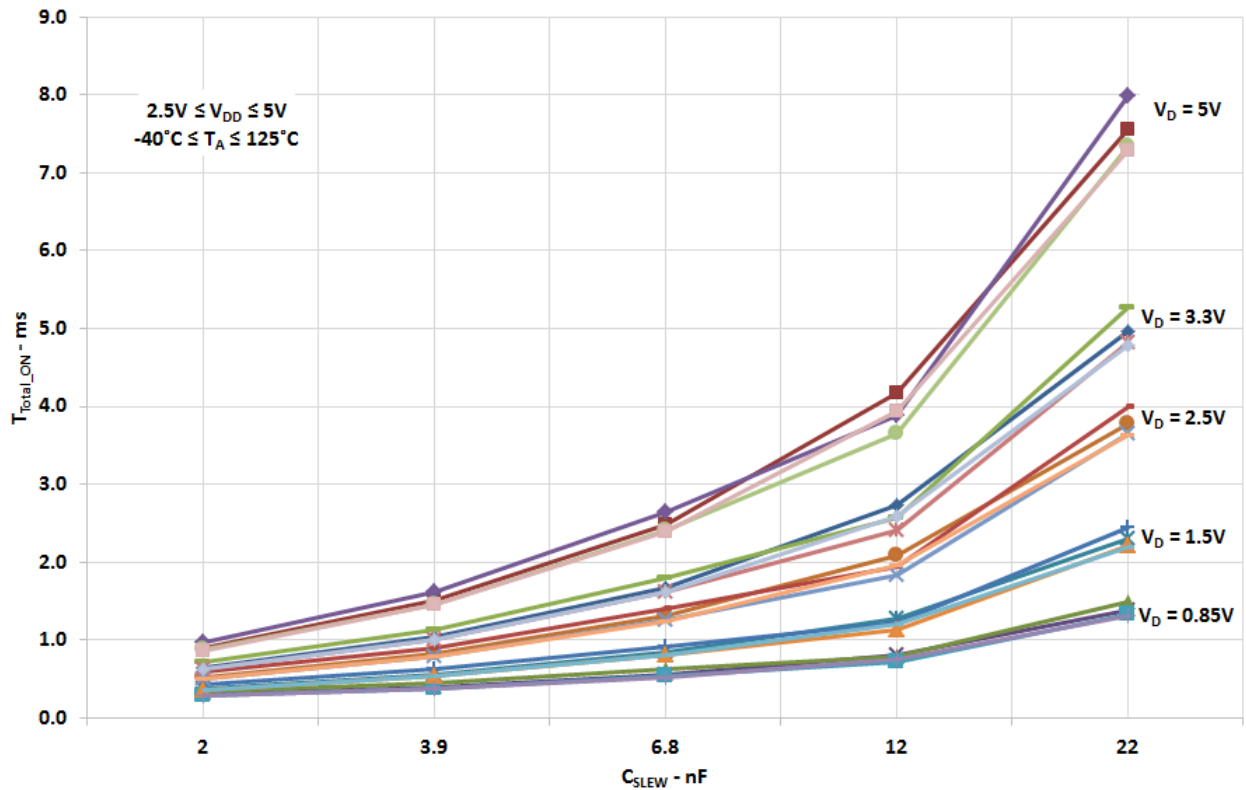



## Typical Operation Waveforms

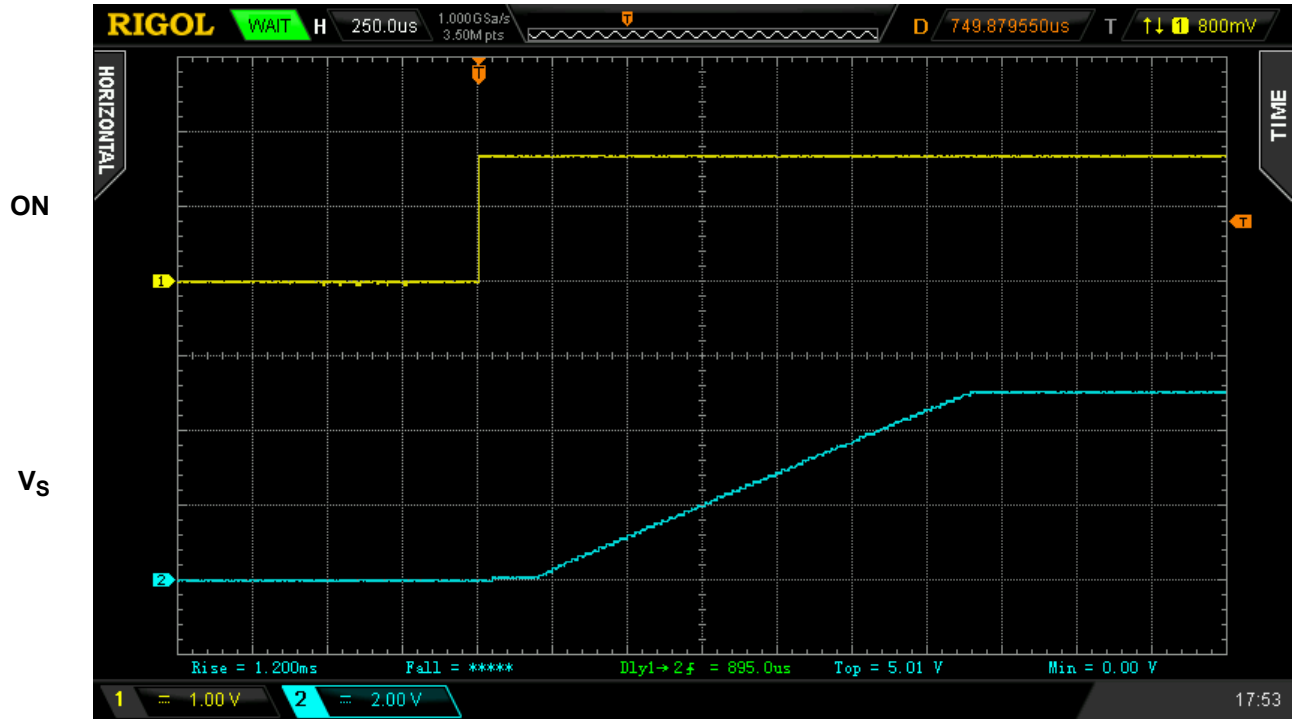

Figure 1. Typical Turn ON operation waveform for  $V_{DD} = V_D = 5\text{ V}$ ,  $C_{SLEW} = 4\text{ nF}$ ,  $C_{LOAD} = 10\text{ }\mu\text{F}$ ,  $R_{LOAD} = 20\text{ }\Omega$

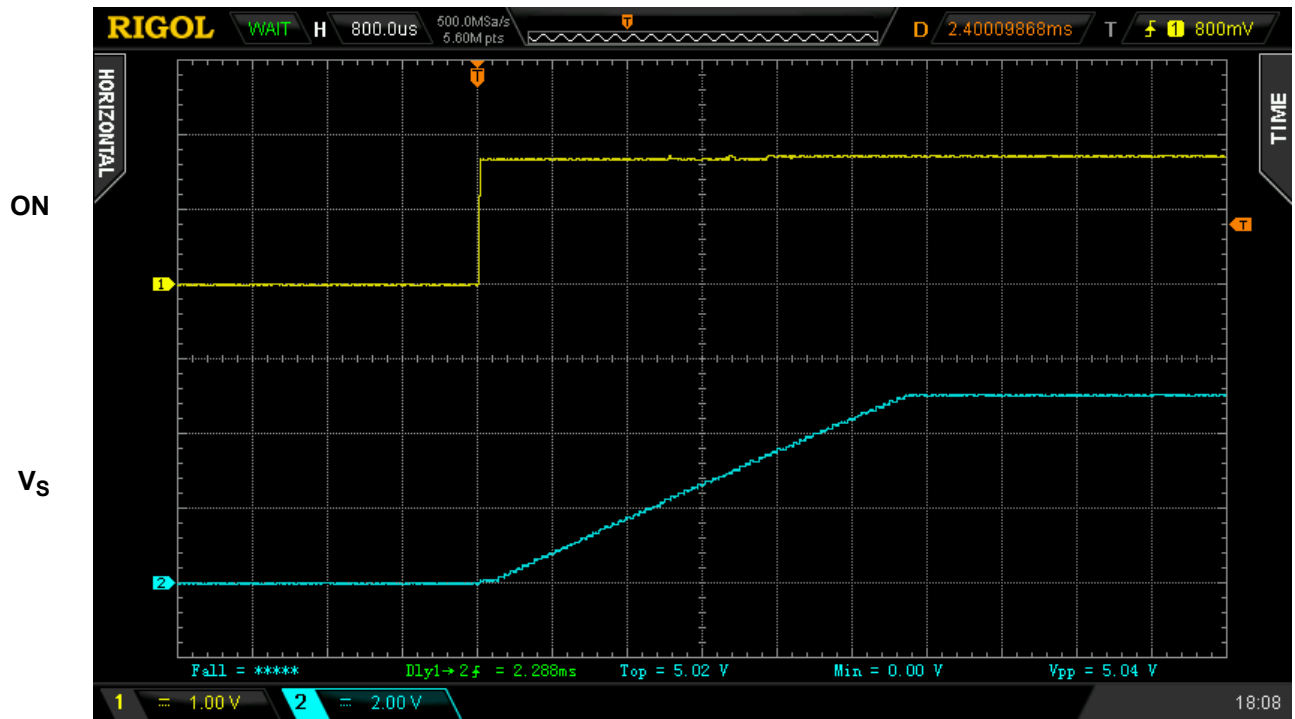
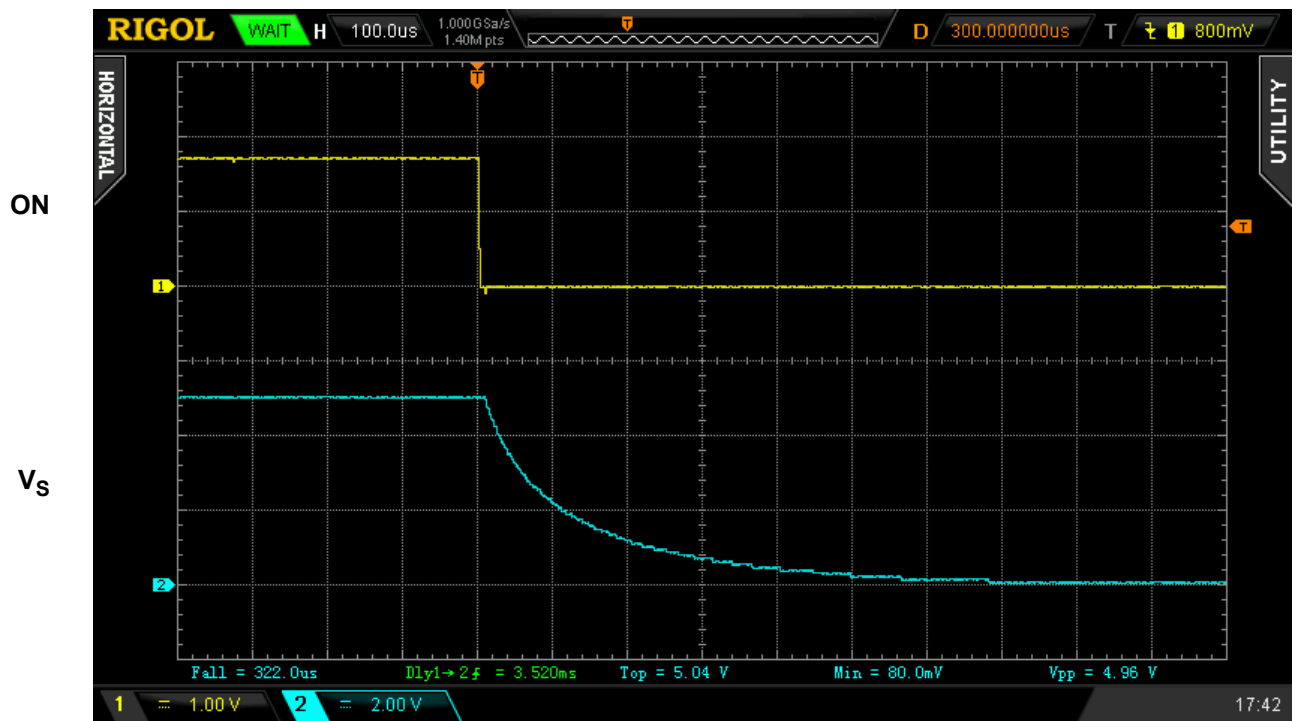
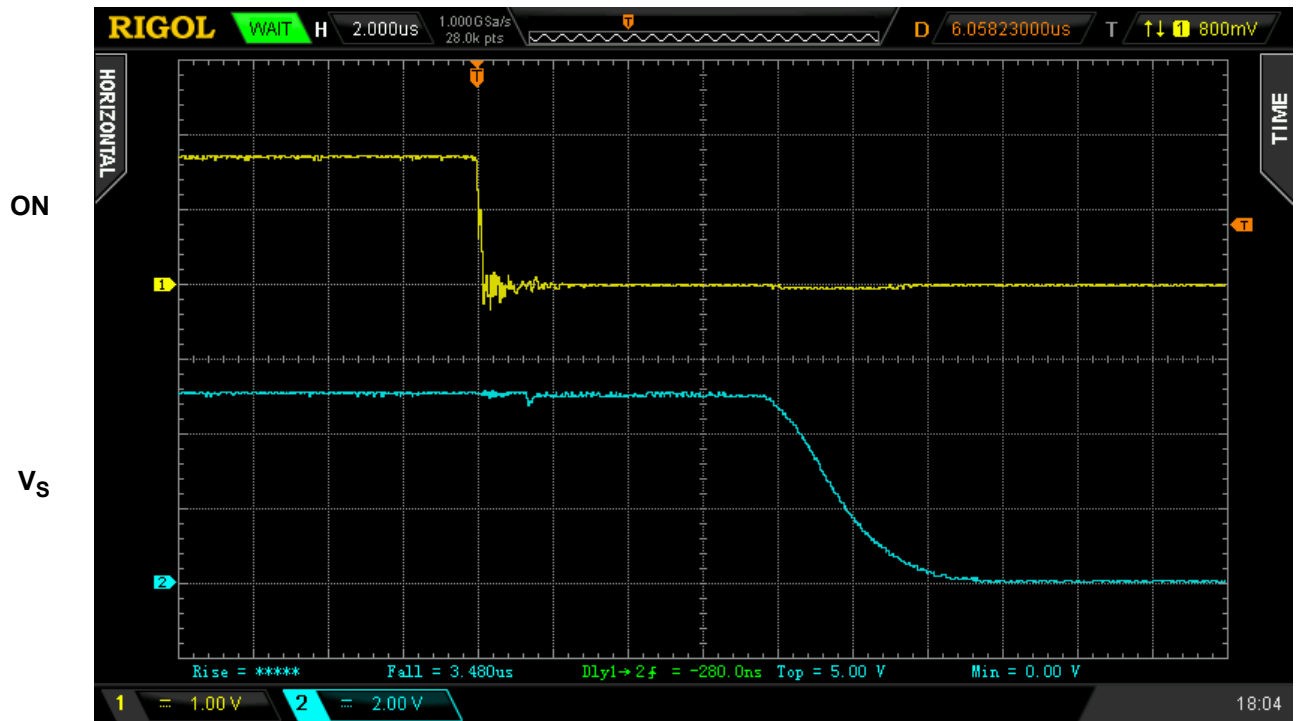

Figure 2. Typical Turn ON operation waveform for  $V_{DD} = V_D = 5\text{ V}$ ,  $C_{SLEW} = 12\text{ nF}$ ,  $C_{LOAD} = 10\text{ }\mu\text{F}$ ,  $R_{LOAD} = 20\text{ }\Omega$







## SLG59M1658V Power-Up/Power-Down Sequence Considerations

To ensure glitch-free power-up under all conditions, apply  $V_{DD}$  first, followed by  $V_D$  after  $V_{DD}$  exceeds 1 V. Then allow  $V_D$  to reach 90% of its max value before toggling the ON pin from Low-to-High. Likewise, power-down in reverse order.

If  $V_{DD}$  and  $V_D$  need to be powered up simultaneously, glitching can be minimized by having a suitable load capacitor. A 10  $\mu$ F  $C_{LOAD}$  will prevent glitches for rise times of  $V_{DD}$  and  $V_D$  less than 2 ms.

If the ON pin is toggled HIGH before  $V_{DD}$  and  $V_D$  have reached their steady-state values, the IPS timing parameters may differ from datasheet specifications.

The slew rate of output  $V_S$  follows a linear ramp set by a capacitor connected to the CAP pin. A larger capacitor value at the CAP pin produces a slower ramp, reducing inrush current from capacitive loads.

## SLG59M1658V Current Limiting

The SLG59M1658V has two modes of current limiting, differentiated by the output (Source pin) voltage.

### 1. Standard Current Limiting Mode (with Thermal Protection)

When  $V(S) > 250$  mV, the output current is initially limited to the Active Current Limit specification given in the Electrical Characteristics table. The current limiting circuit is very fast and responds within a few micro-seconds to sudden loads. When overload is sensed, the current limiting circuit increases the FET resistance to keep the current from exceeding the Active Current Limit.

However, if an overload condition persists, the die temperature rise due to the increased FET resistance while at maximum current can activate Thermal Protection. If the die temperature exceeds the  $THERM_{ON}$  specification, the FET is shut completely OFF, allowing the die to cool. When the die cools to the  $THERM_{OFF}$  temperature, the FET is allowed to turn back on. This process may repeat as long as the overload condition is present.

### 2. Short Circuit Current Limiting Mode (with Thermal Protection)

When  $V(S) < 250$  mV (which is the case with a hard short, such as a solder bridge on the power rail), the current is limited to approximately 500 mA. Thermal Protection is also present, but since the Short Circuit Current Limit is much lower than Standard Current Limit, activation may only occur at higher ambient temperatures.

For more information on Silego GreenFET3 integrated power switch features, please visit our [Application Notes](#) page at our website and see [App Note "AN-1068 GreenFET3 Integrated Power Switch Basics"](#).



Package Top Marking System Definition

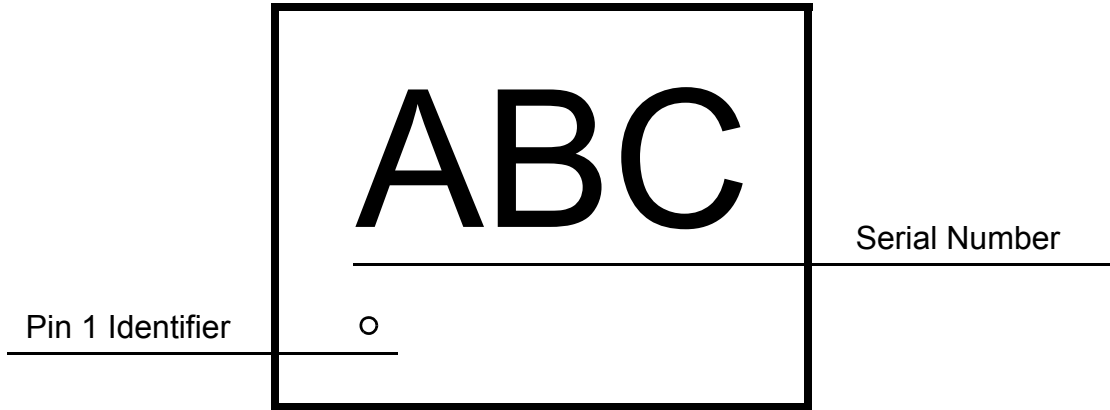

ABC - Part Serial Number Field  
each A, B, and C character can be A-Z and 0-9



### Package Drawing and Dimensions

8 Lead STDFN Package 1.0 x 1.6 mm (Fused Lead)

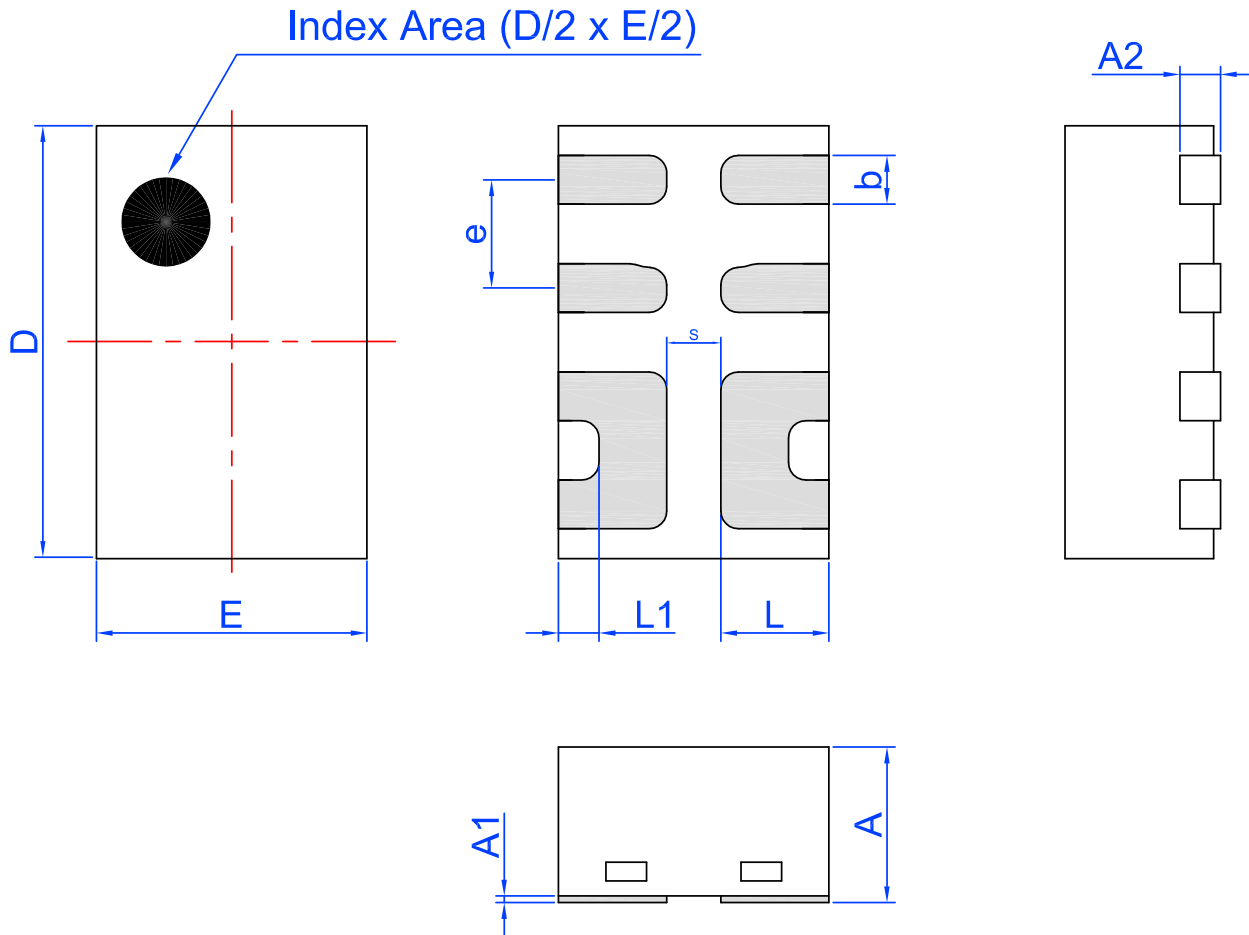

Unit: mm

Symbol	Min	Nom.	Max	Symbol	Min	Nom.	Max
A	0.50	0.55	0.60	D	1.55	1.60	1.65
A1	0.005	-	0.060	E	0.95	1.00	1.05
A2	0.10	0.15	0.20	L	0.35	0.40	0.45
b	0.13	0.18	0.23	L1	0.10	0.15	0.20
e	0.40 BSC			S	0.2 REF		



**Tape and Reel Specifications**

Package Type	# of Pins	Nominal Package Size [mm]	Max Units		Reel & Hub Size [mm]	Leader (min)		Trailer (min)		Tape Width [mm]	Part Pitch [mm]
			per Reel	per Box		Pockets	Length [mm]	Pockets	Length [mm]		
STDFN 8L 1x1.6mm 0.4P FC Green	8	1.0 x 1.6 x 0.55	3,000	3,000	178 / 60	100	400	100	400	8	4

**Carrier Tape Drawing and Dimensions**

Package Type	Pocket BTM Length	Pocket BTM Width	Pocket Depth	Index Hole Pitch	Pocket Pitch	Index Hole Diameter	Index Hole to Tape Edge	Index Hole to Pocket Center	Tape Width
	A0	B0	K0	P0	P1	D0	E	F	W
STDFN 8L 1x1.6mm 0.4P FC Green	1.12	1.72	0.7	4	4	1.55	1.75	3.5	8

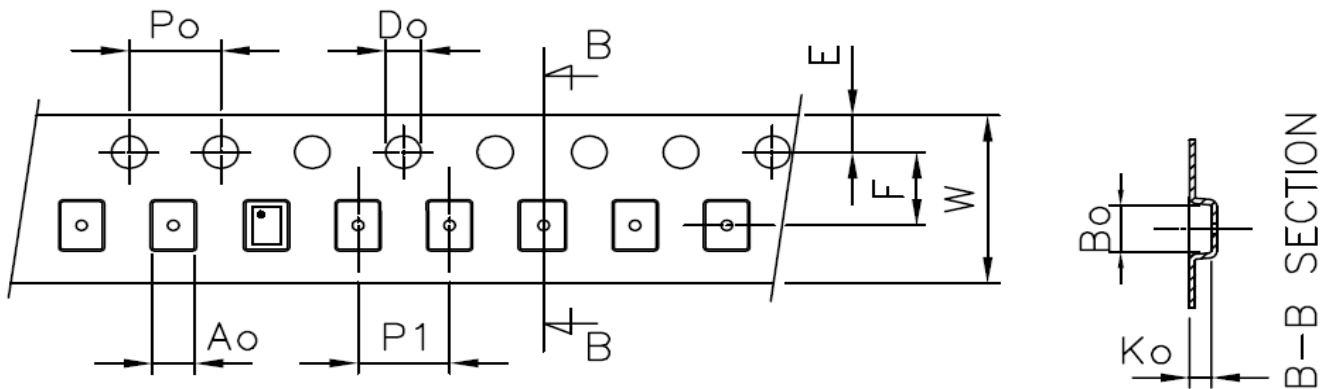

**Recommended Reflow Soldering Profile**

Please see IPC/JEDEC J-STD-020: latest revision for reflow profile based on package volume of 0.88 mm<sup>3</sup> (nominal). More information can be found at [www.jedec.org](http://www.jedec.org).



---

**Revision History**

Date	Version	Change
2/23/2017	1.00	Production Release

## X-ON Electronics

Largest Supplier of Electrical and Electronic Components

*Click to view similar products for [Power Switch ICs - Power Distribution](#) category:*

*Click to view products by [Silego](#) manufacturer:*

Other Similar products are found below :

[TCK111G,LF\(S\)](#) [FPF1018](#) [DS1222](#) [TCK2065G,LF](#) [SZNCP3712ASNT3G](#) [MIC2033-05BYMT-T5](#) [MIC2033-12AYMT-T5](#) [MIC2033-05BYM6-T5](#) [SLG5NT1437VTR](#) [SZNCP3712ASNT1G](#) [DML1008LDS-7](#) [KTS1670EDA-TR](#) [KTS1640QGDV-TR](#) [KTS1641QGDV-TR](#) [NCV459MNWTBG](#) [FPF2260ATMX](#) [U6513A](#) [U6119S](#) [MIC2012YM-TR](#) [MAX14919ATP+](#) [MC33882PEP](#) [TPS2021IDRQ1](#) [TPS2104DBVR](#) [MIC2098-1YMT-TR](#) [MIC94062YMT TR](#) [MP6231DN-LF](#) [MIC2075-2YM](#) [MIC2095-2YMT-TR](#) [MIC94068YML-TR](#) [SIP32461DB-T2-GE1](#) [NCP335FCT2G](#) [TCK105G,LF\(S\)](#) [AP2151DSG-13](#) [MIC94094YC6-TR](#) [MIC94064YC6-TR](#) [MIC2505-1YM](#) [MIC94305YMT-TR](#) [MIC94081YFT-TR](#) [MIC94042YFL-TR](#) [MIC94041YFL-TR](#) [MIC2005-1.2YM6-TR](#) [TPS2032QDRQ1](#) [SIP32510DT-T1-GE3](#) [NCP333FCT2G](#) [NCP331SNT1G](#) [TPS2092DR](#) [TPS2063DR](#) [TPS2042P](#) [MIC2008YML-TR](#) [MIC2040-1YMM](#)