



## Ultra-small 40 mΩ 1.0 A GreenFET 3 Load Switch with Discharge

### General Description

The SLG5NT1464V is designed for load switching applications. The part comes with one 40 mΩ 1.0 A rated MOSFET controlled by a single ON control pin. The MOSFET's ramp rate is adjustable depending on the input current level of the ON pin.

The product is packaged in an ultra-small 1.0 x 1.0 mm package.

### Features

- One 40 mΩ 1.0 A MOSFET
- One integrated VGS Charge Pump
- User selectable ramp rate with external resistor
- Integrated Discharge Resistor
- Over Temperature Protection
- Pb-Free / Halogen-Free / RoHS compliant
- STDFN 4L, 1.0 x 1.0 x 0.55 mm

### Pin Configuration

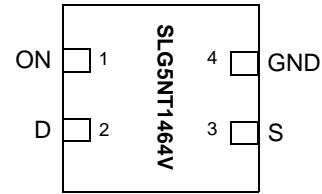

**4-pin STDFN**  
(Top View)

### Block Diagram

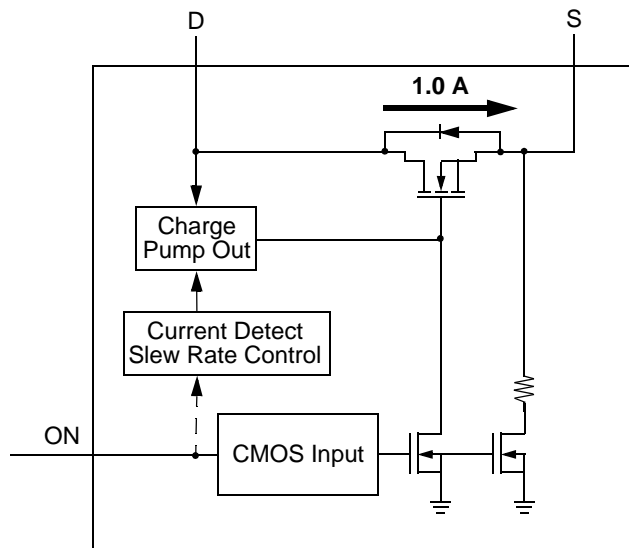



## Pin Description

Pin #	Pin Name	Type	Pin Description
1	ON	Input	Turns on MOSFET. Configurable slew rate control depending on input current.
2	D	MOSFET	Drain of Power MOSFET
3	S	MOSFET	Source of Power MOSFET
4	GND	GND	Ground

## Ordering Information

Part Number	Type	Production Flow
SLG5NT1464V	STDFN 4L	Extended Commercial, -20 °C to 70 °C
SLG5NT1464VTR	STDFN 4L (Tape and Reel)	Extended Commercial, -20 °C to 70 °C

## Application Diagram

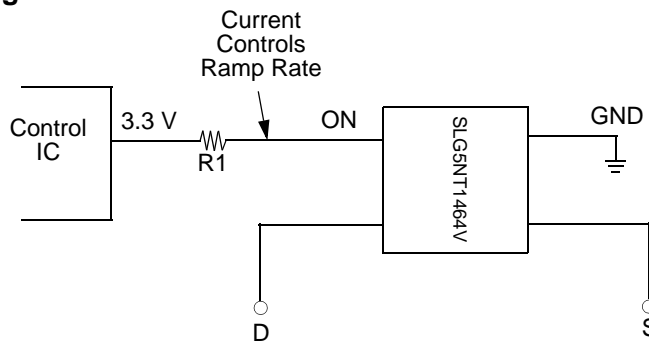

## Adjustable Ramp Rate vs. ON Pin Current (5.5 V, 25 °C)

I <sub>ON</sub>	T <sub>SLEW</sub> (typ)
20 μA	0.56 V/ms
50 μA	1.34 V/ms
100 μA	2.53 V/ms
150 μA	3.71 V/ms
200 μA	4.68 V/ms
250 μA	5.63 V/ms

## Adjustable Slew Rate (ON Pin 2)

SLG5NT1464V has a built in configurable slew control feature. The configurable slew control uses current detection method on Pin 2. When ON voltage rise above ON\_VIH\_INI (1.2 V typical), the slew control circuit will measure the current flowing into Pin 2. Based on the current flowing into pin 2, different slew rates will be selected by the internal control circuit. See I<sub>ON</sub> vs. T<sub>slew</sub> table on page 2. The slew rate is configurable by selecting a different R1 resistor value as shown on application diagram on page 2. Calculating the R1 value depends on both the desired slew rate, and the VOH level of the device driving the ON Pin 2.

$$ON\_Current = (GPIO\_VOH - ON\_VREF (1.05 V typical)) / R1$$



## Absolute Maximum Ratings

Parameter	Description	Conditions	Min.	Typ.	Max.	Unit
$V_D$	Power Supply		--	--	6	V
$T_S$	Storage Temperature		-65	--	150	°C
$ESD_{HBM}$	ESD Protection	Human Body Model	2000	--	--	V
$W_{DIS}$	Package Power Dissipation		--	--	0.5	W
MOSFET $IDS_{PK}$	Peak Current from Drain to Source	For no more than 1 ms with 1% duty cycle	--	--	1.5	A

Note: Stresses greater than those listed under "Absolute Maximum Ratings" may cause permanent damage to the device. This is a stress rating only and functional operation of the device at these or any other conditions above those indicated in the operational sections of this specification is not implied. Exposure to absolute maximum rating conditions for extended periods may affect reliability.

## Electrical Characteristics

$T_A = -20$  to  $70$  °C (unless otherwise stated)

Parameter	Description	Conditions	Min.	Typ.	Max.	Unit
$V_D$	Power Supply Voltage	-20 to 70°C	2.5	--	5.5	V
$I_{DD}$	Power Supply Current (PIN 2)	when OFF	--	0.1	1	μA
		when ON, No load	--	18	30	μA
$R_{DS_{ON}}$	Static Drain to Source ON Resistance	$T_A$ 25°C MOSFET	--	40	50	mΩ
		$T_A$ 70°C MOSFET	--	50	55	mΩ
$IDS$	Operating Current	$V_D = 2.5$ V to 5.5 V	--	--	1.0	A
$T_{Delay\_ON}$	ON pin Delay Time	50% ON to Ramp Begin Input Current (PIN 1) = 20 μA, $V_D = 5$ V, Source_Cap = 10 μF, $R_L = 20$ Ω	0	2.4	4.0	ms
$T_{Total\_ON}$	Total Turn On Time	50% ON to 90% $V_S$	Configurable <sup>1</sup>			ms
		Example: Input Current (PIN 1) = 20 μA, $V_D = 5$ V, Source_Cap = 10 μF, $R_L = 20$ Ω	--	11.7	--	ms
$T_{SLEWRATE}$	Slew Rate	10% $V_S$ to 90% $V_S$	Configurable <sup>1</sup>			V/ms
		Example: Input Current (PIN 1) = 20 μA, $V_D = 5$ V, Source_Cap = 10 μF, $R_L = 20$ Ω	--	0.56	--	V/ms
$R_{DIS}$	Discharge Resistance		100	150	300	Ω
$ON\_V_{REF}$	ON Pin Reference Voltage <sup>2</sup>		0.99	1.05	1.10	V
$ON\_V_{IH\_INI}$	Initial Turn On Voltage	Internal Charge Pump ON	1.2	--	$V_{DD}$	V
$ON\_V_{IL}$	Low Input Voltage on ON pin	Internal Charge Pump OFF	-0.3	0	0.3	V
$ON\_R$	Input Impedance on ON pin		100	--	--	MΩ
$THERM_{ON}$	Thermal shutoff turn-on temperature		--	120	--	°C
$THERM_{OFF}$	Thermal shutoff turn-off temperature		--	100	--	°C
$THERM_{TIME}$	Thermal shutoff time		--	--	1	ms
$T_{Delay\_OFF}$	OFF Delay Time	50% ON to $V_S$ Fall, $V_D = 5$ V, $R_L = 20$ Ω	--	6.5	20	μs
$T_{FALL}$	$V_S$ Fall Time	90% $V_S$ to 10% $V_S$ , $V_D = 5$ V, $R_L = 20$ Ω	--	1.2	2	μs

Notes:  
1. Refer to table for configuration details.  
2. Voltage before ON pin resistor needs to be higher than 1.2 V to generate required  $I_{ON}$



### Slew Rate vs. ON Current

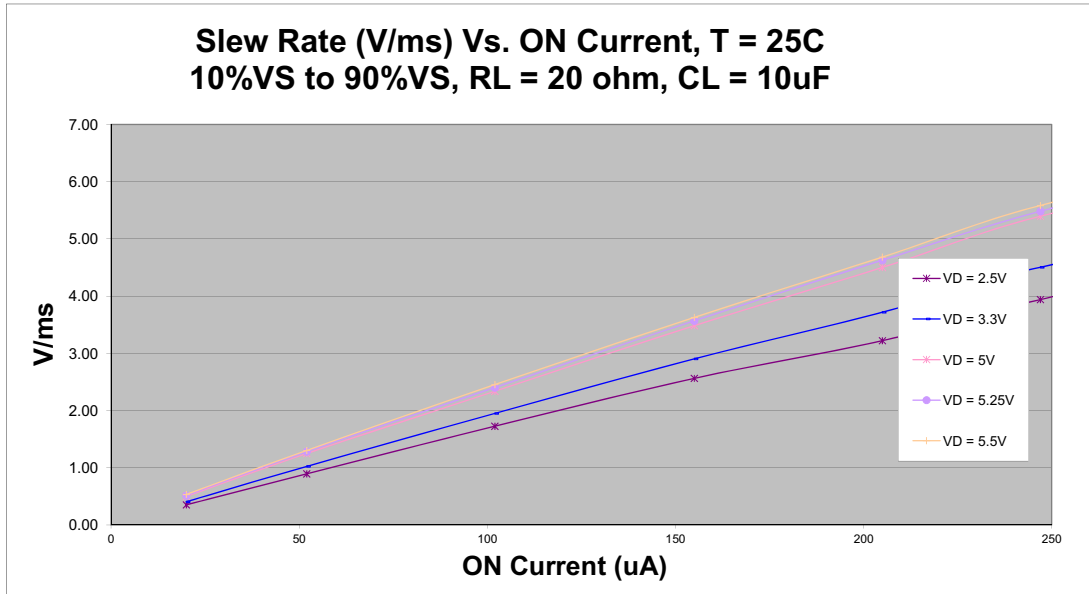

### T<sub>Total\_ON</sub> vs. On Current

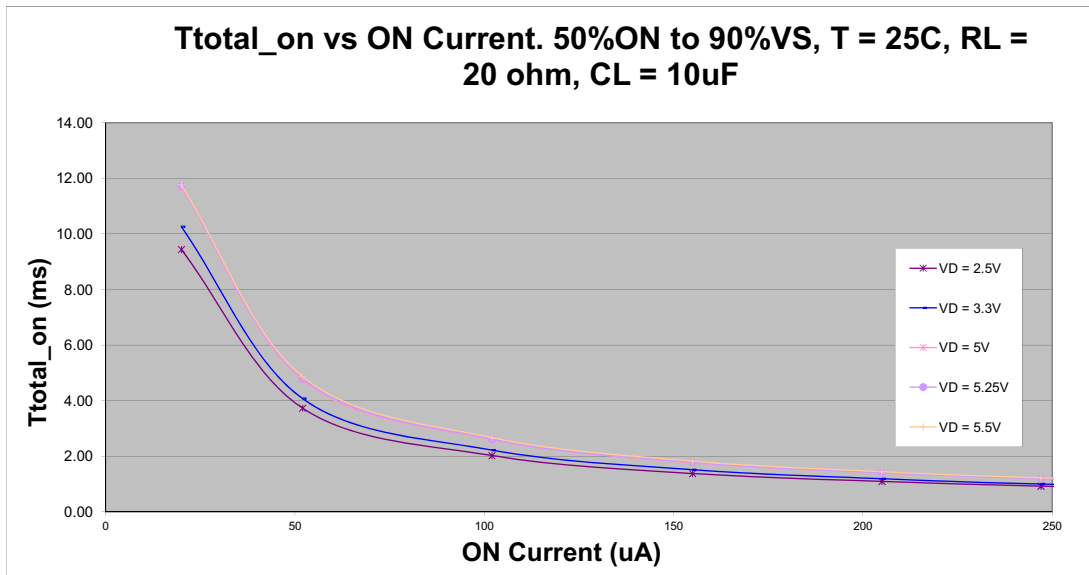



### $T_{Total\_ON}$ , $T_{ON\_Delay}$ and Slew Rate Measurement

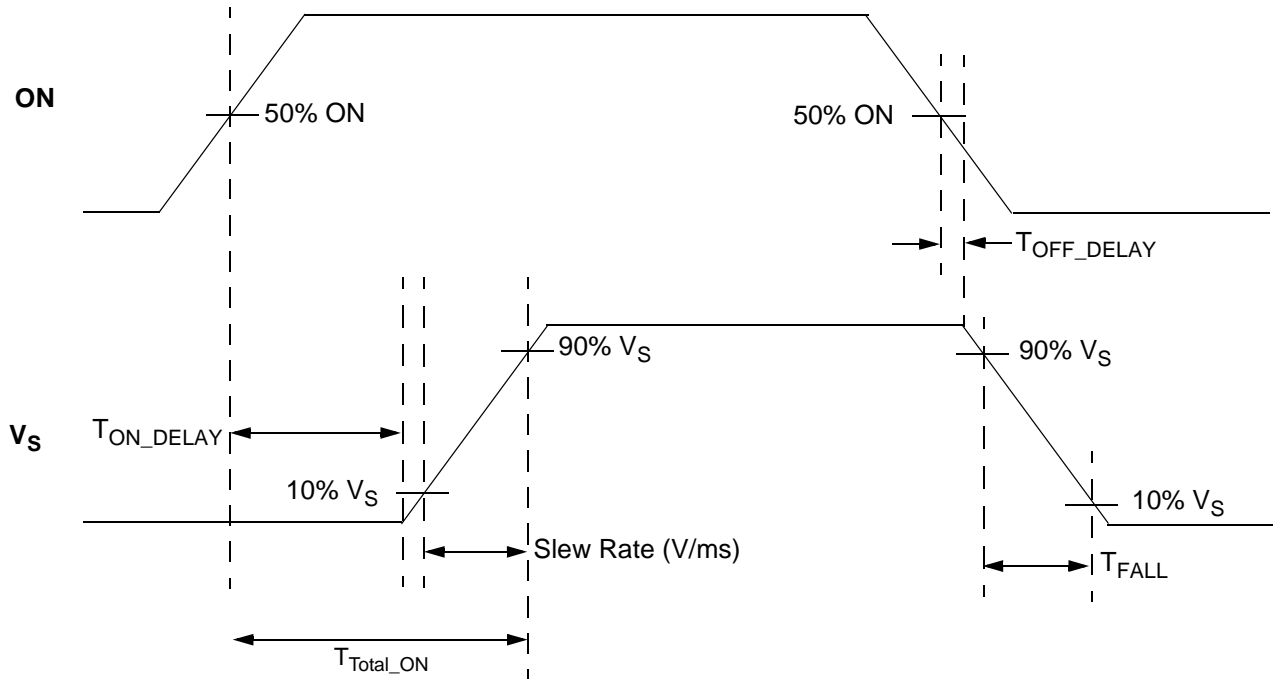

### SLG5NT1464V Layout Suggestion

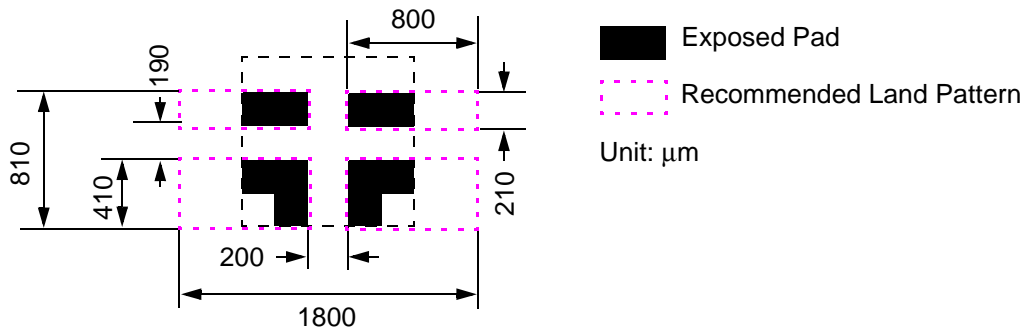



Package Top Marking System Definition

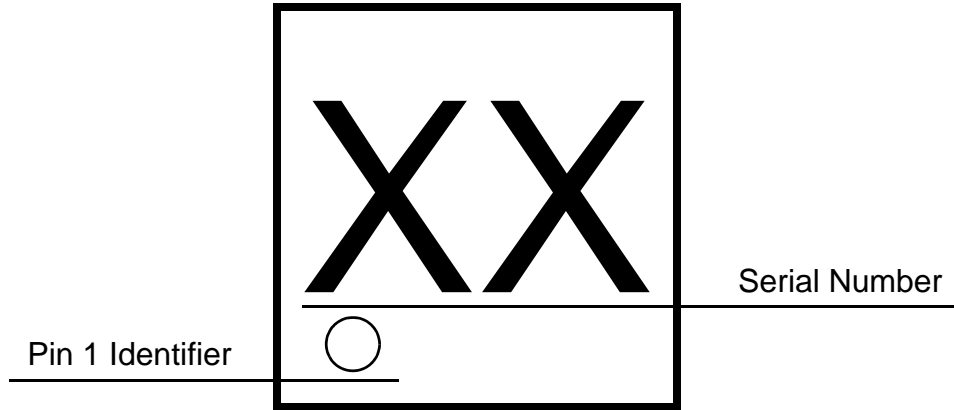



### Package Drawing and Dimensions

4 Lead STDFN Package 1.0 x 1.0 mm

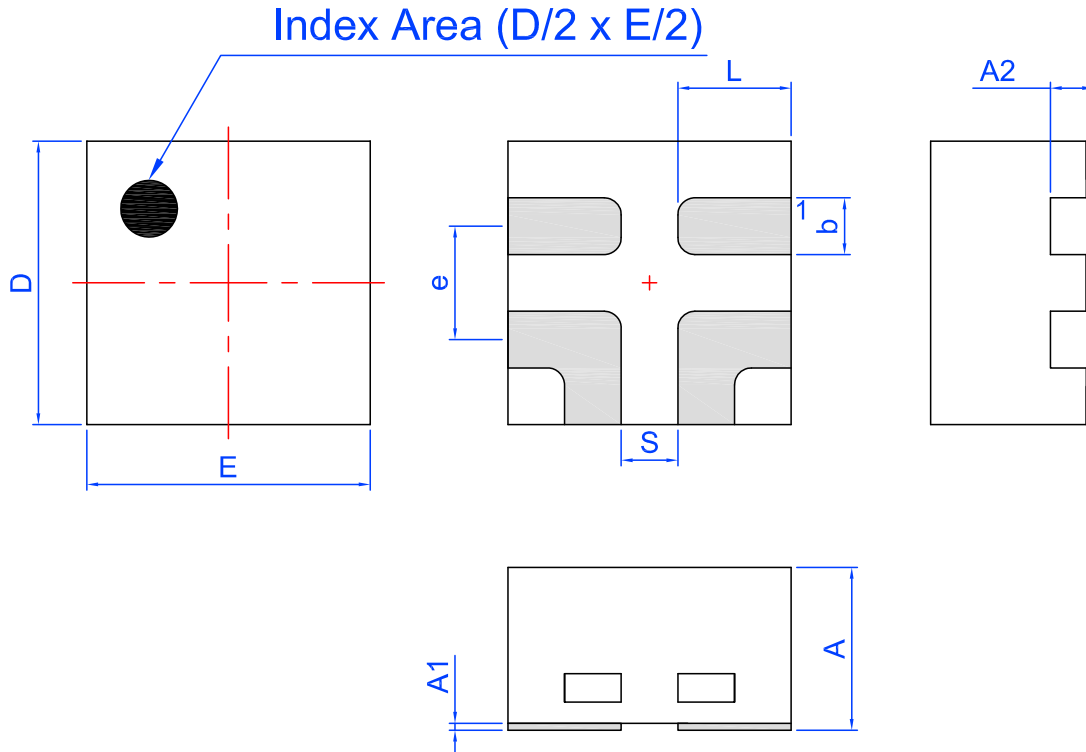

Unit: mm

Symbol	Min	Nom.	Max	Symbol	Min	Nom.	Max
A	0.50	0.55	0.60	D	0.95	1.00	1.05
A1	0.005	-	0.060	E	0.95	1.00	1.05
A2	0.10	0.15	0.20	L	0.35	0.40	0.45
b	0.15	0.20	0.25	S	0.2 REF		
e	0.40 BSC						



**Tape and Reel Specifications**

Package Type	# of Pins	Nominal Package Size [mm]	Max Units		Reel & Hub Size [mm]	Leader (min)		Trailer (min)		Tape Width [mm]	Part Pitch [mm]
			per Reel	per Box		Pockets	Length [mm]	Pockets	Length [mm]		
STDFN 4L Green	4	1.0 x 1.0 x 0.55	8000	8000	178 / 60	200	400	200	400	8	2

**Carrier Tape Drawing and Dimensions**

Package Type	Pocket BTM Length	Pocket BTM Width	Pocket Depth	Index Hole Pitch	Pocket Pitch	Index Hole Diameter	Index Hole to Tape Edge	Index Hole to Pocket Center	Tape Width
	A0	B0	K0	P0	P1	D0	E	F	W
STDFN 4L Green	1.16	1.16	0.63	4	2	1.5	1.75	3.5	8

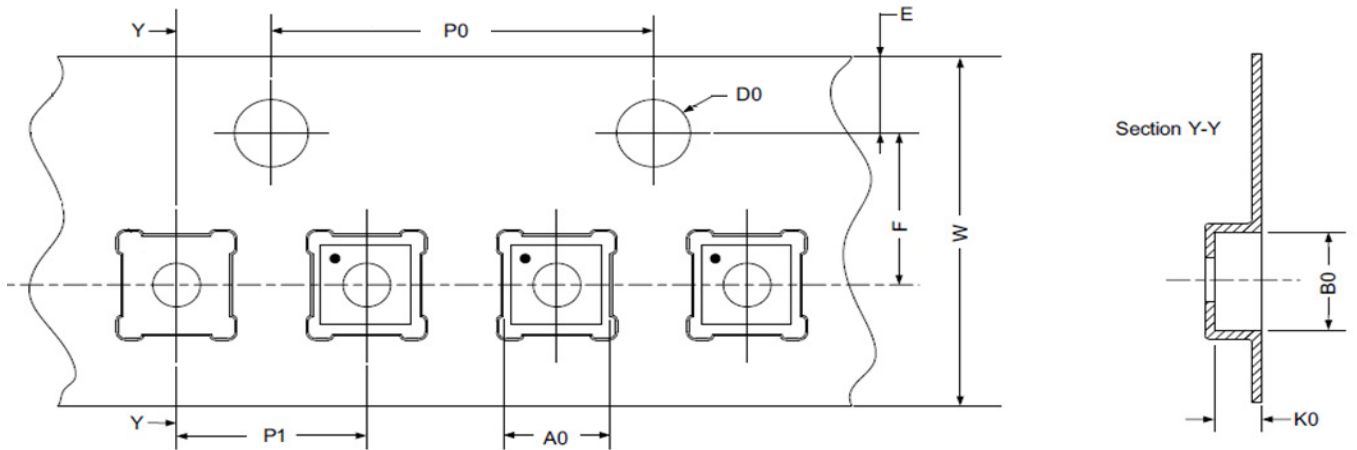

Refer to EIA-481 specification

**Recommended Reflow Soldering Profile**

Please see IPC/JEDEC J-STD-020: latest revision for reflow profile based on package volume of 0.55 mm<sup>3</sup> (nominal). More information can be found at [www.jedec.org](http://www.jedec.org).



## X-ON Electronics

Largest Supplier of Electrical and Electronic Components

*Click to view similar products for [Power Switch ICs - Power Distribution](#) category:*

*Click to view products by [Silego](#) manufacturer:*

Other Similar products are found below :

[TCK111G,LF\(S\)](#) [FPF1018](#) [DS1222](#) [TCK2065G,LF](#) [SZNCP3712ASNT3G](#) [MIC2033-05BYMT-T5](#) [MIC2033-12AYMT-T5](#) [MIC2033-05BYM6-T5](#) [SLG5NT1437VTR](#) [SZNCP3712ASNT1G](#) [NCV330MUTBG](#) [DML1008LDS-7](#) [KTS1670EDA-TR](#) [KTS1640QGDV-TR](#) [KTS1641QGDV-TR](#) [NCV459MNWTBG](#) [FPF2260ATMX](#) [U6513A](#) [U6119S](#) [NCP45780IMN24RTWG](#) [MAX14919ATP+](#) [MC33882PEP](#) [TPS2021HDRQ1](#) [TPS2104DBVR](#) [MIC2098-1YMT-TR](#) [MIC94062YMT TR](#) [MP6231DN-LF](#) [MIC2075-2YM](#) [MIC2095-2YMT-TR](#) [MIC94068YML-TR](#) [SIP32461DB-T2-GE1](#) [NCP335FCT2G](#) [FPF2701MX](#) [TCK105G,LF\(S\)](#) [AP2151DSG-13](#) [MIC94094YC6-TR](#) [MIC94064YC6-TR](#) [MIC2505-1YM](#) [MIC94042YFL-TR](#) [MIC94041YFL-TR](#) [MIC2005-1.2YM6-TR](#) [TPS2032QDRQ1](#) [SIP32510DT-T1-GE3](#) [NCP333FCT2G](#) [NCP331SNT1G](#) [TPS2092DR](#) [TPS2063DR](#) [TPS2042P](#) [MIC2008YML-TR](#) [MIC2040-1YMM](#)