



General Description

Silego SLG7NT128V is a low power and small form device. The SoC is housed in a 2mm x 2mm TDFN package which is optimal for using with small devices.

Features

- Low Power Consumption
- 3.3V Supply
- Pb-Free / RoHS Compliant
- Halogen-Free
- TDFN-8 Package

Pin Configuration

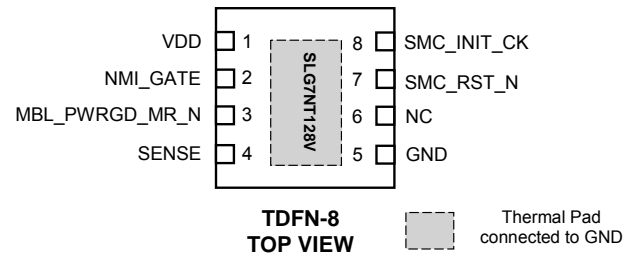

Output Summary

- 2 Outputs – Open Drain



Pin Configuration

Pin #	Pin Name	Type	Pin Description
1	VDD	Power	3.3V Supply Voltage
2	NMI_GATE	Input	Digital Input
3	MBL_PWRGD_MR_N	Input	Digital Input
4	SENSE	Input	Analog input
5	GND	GND	Ground
6	NC	--	Connect to GND or keep floating
7	SMC_RST_N	Output	Open Drain
8	SMC_INIT_CK	Output	Open Drain
Exposed Bottom Pad	GND	GND	Ground

Ordering Options & Configuration

Part Number	Package Type
SLG7NT128V	V = TDFN-8
SLG7NT128VTR	VTR = TDFN-8 – Tape and Reel (3k units)



Absolute Maximum Ratings

Parameter	Min.	Max.	Unit
V _{DD} to GND	-0.3	4.6	V
Voltage at input pins	-0.3	4.6	V
Current at input pin	-1.0	1.0	mA
Storage temperature range	-65	150	°C
Junction temperature	--	150	°C

Electrical Characteristics

Symbol	Parameter	Condition / Note	Min	Typ	Max	Unit
V _{DD}	Supply Voltage		3.0	3.3	3.6	V
I _Q	Quiescent Current	Static Inputs and Outputs	--	30	--	μA
T _A	Operating temperature		-40	25	85	°C
V _{AIR}	Analog Input Voltage Range		0	--	2.2	V
V _{IH}	HIGH-Level Input Voltage	Logic Input	1.8	--	3.3	V
I _{IH}	HIGH-Level Input Leakage Current	Logic Input Pins; VIN=3.3V	-100	--	100	nA
I _{IL}	LOW-Level Input Leakage Current	Logic Input Pins; VIN=0V	-100	--	100	nA
V _{IL}	LOW-Level Input Voltage	Logic Input	-0.3	--	0.8	V
V _{OL}	LOW-Level Output Voltage	Open Drain Logic Level Outputs	0	--	0.4	V
I _{OH}	Low-Level Output Current	Open Drain	--	20	--	mA
V _{REF}	Reference voltage	Analog Comparator 0	--	400	--	mV
V _{HYST}	Analog Comparator hysteresis	Analog Comparator 0	--	50	--	mV
R _{PULL UP}	Internal Pull Up Resistance	Pull up on PIN7 and PIN8	80	100	120	kΩ
T _{StUp}	Start Up Time		--	7	--	ms



Description

This is a special oscillator with supervisor system. Three inputs are used to control the oscillator. PIN4 controls the voltage supply of the chip. If supply voltage decreases to 2.8V, the chip disables the oscillator and sets SMC_INICK to LOW. When voltage > 2.8V is detected on the SENSE pin, SMC_RST_N is set to HIGH with 20 ms delay and enables the oscillator. MBL_PWRGD_MR_N is used for manual reset of SMC_RST_N. Use NMI_GATE to disable the oscillator.

Typical Application Circuit

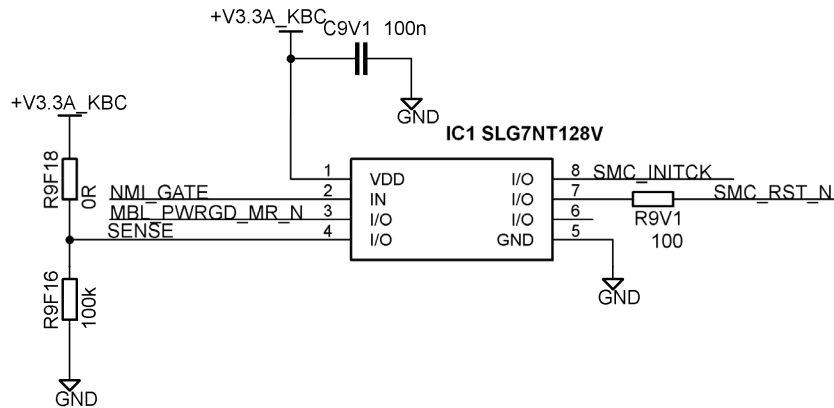

Timing Diagrams

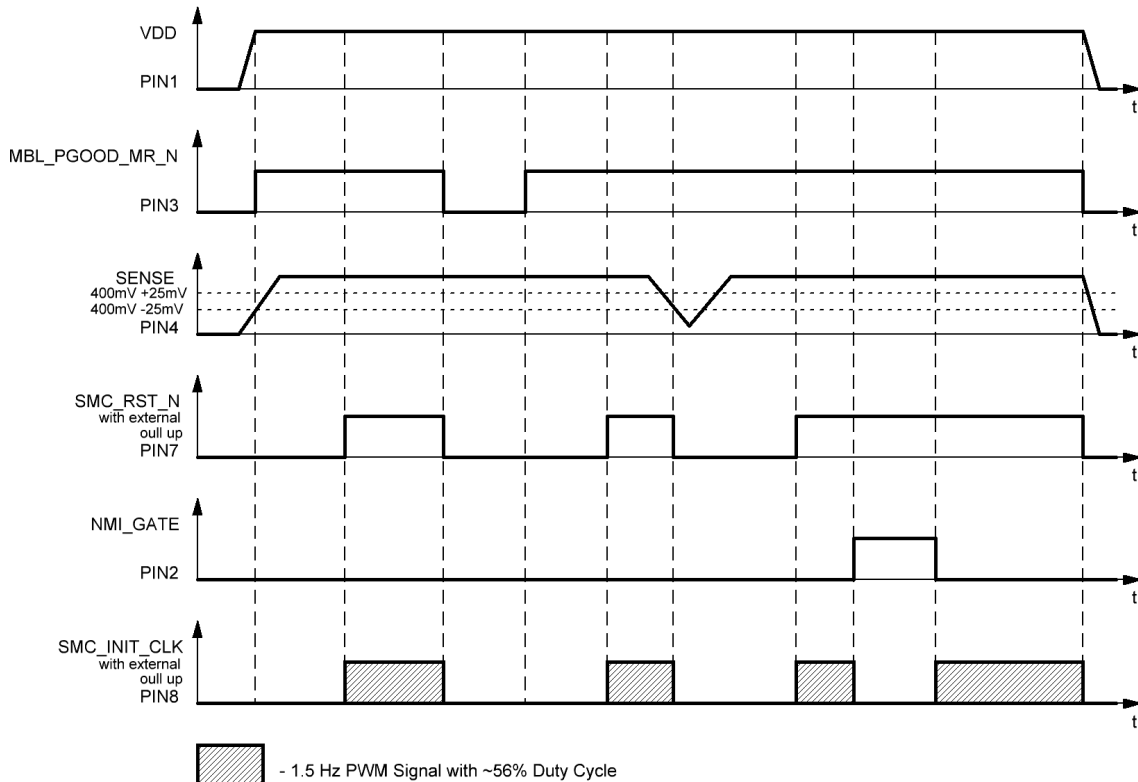



SLG7NT128V Functionality Waveforms

Channel 1 (yellow/top line) – Pin# 8 (SMC_INIT_CLK)

Channel 2 (light blue/2nd line) – Pin# 7 (SMC_RST_N)

Channel 3 (magenta /3rd line) – Pin# 3 (MBL_PGOOD_MR)

Channel 4 (green /bottom line) – Pin# 2 (NMI_GATE)

1. OSC enable

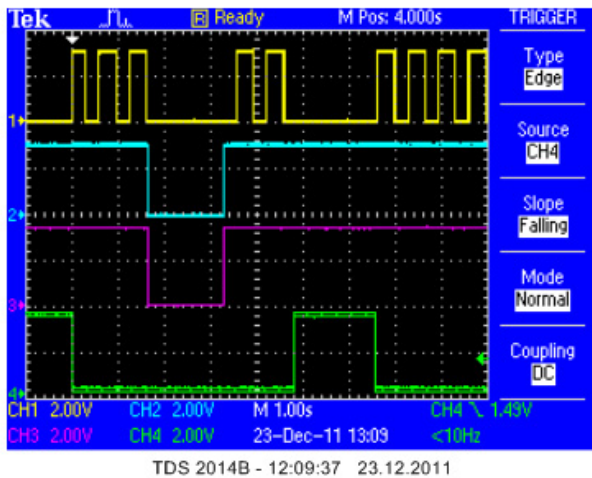

2. 20ms delay supervisor

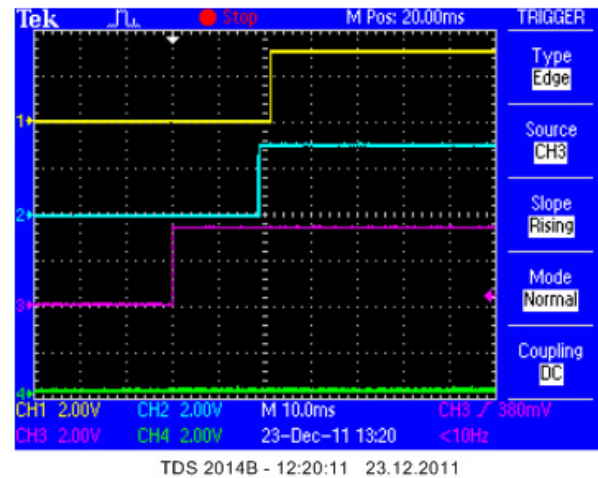

Channel 1 (yellow/top line) – pin# 8 (SMC_INIT_CLK)

Channel 2 (light blue/2nd line) – pin# 7 (SMC_RST_N)

Channel 3 (magenta /3rd line) – pin# 4 (SENSE)

Channel 4 (green /bottom line) – pin# 2 (NMI_GATE)

3. Power voltage detect

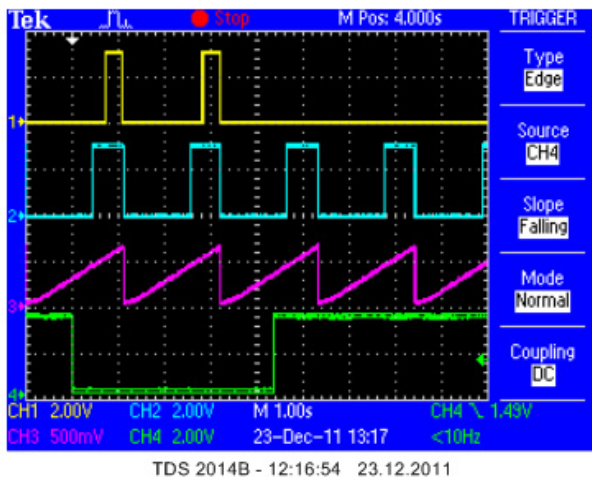

Package Top Marking

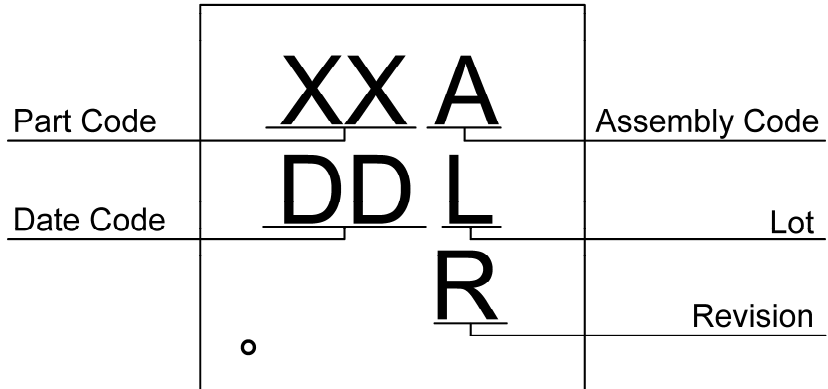

- XX – Part Code Field: identifies the specific device configuration
- A – Assembly Code Field: Assembly Location of the device.
- DD – Date Code Field: Coded date of manufacture
- L – Lot Code: Designates Lot #
- R – Revision Code: Device Revision

Datasheet Revision	Programming Code Number	Part Code	Revision	Date
0.14	01	KN	A	03/22/2013



Package Drawing and Dimensions

TDFN-8 Package

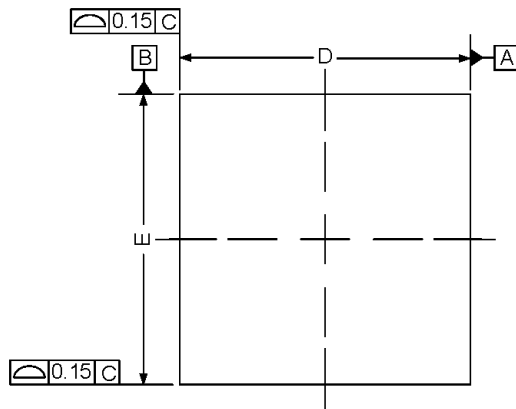

Symbol	Min (mm)	NOM (mm)	Max (mm)
A	0.70	0.75	0.80
A1	0.00	--	0.05
A2	--	0.55	--
A3	--	0.20	--
b	0.20	0.25	0.30
D	1.90	2.00	2.10
D2	1.50	1.60	1.70
E	1.90	2.00	2.10
E2	0.80	0.90	1.00
e	0.50 BSC		
L	0.20	0.30	0.40

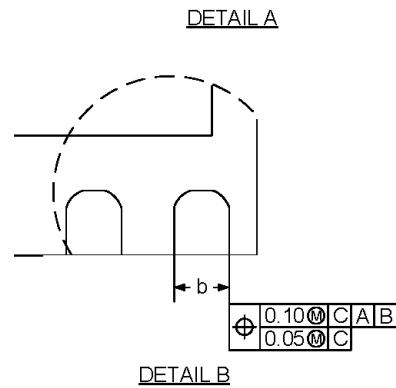
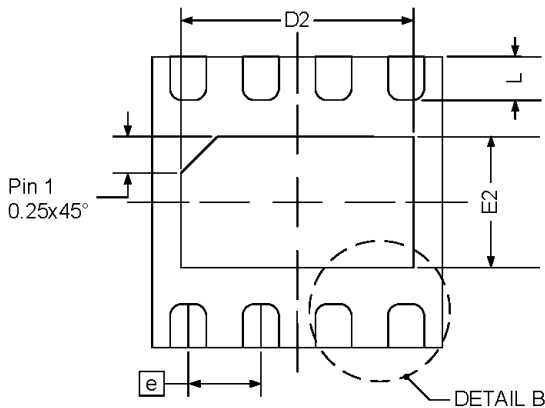
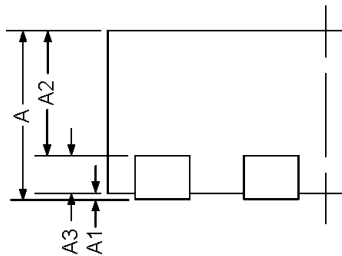
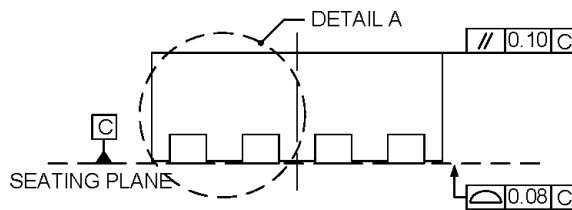



Tape and Reel Specification

Package Type	# of Pins	Nominal Package Size (mm)	Max Units		Reel & Hub Size (mm)	Trailer A		Leader B		Pocket (mm)	
			per reel	per box		Pockets	Length (mm)	Pockets	Length (mm)	Width	Pitch
TDFN 8L 2x2mm Green	8	2x2x0.75	3000	3000	178/60	42	168	42	168	8	4

Carrier Tape Drawing and Dimensions

Package Type	Pocket BTM Length (mm)	Pocket BTM Width (mm)	Pocket Depth (mm)	Index Hole Pitch (mm)	Pocket Pitch (mm)	Index Hole Diameter (mm)	Index Hole to Tape Edge (mm)	Index Hole to Pocket Center (mm)	Tape Width (mm)
	A0	B0	K0	P0	P1	D0	E	F	W
TDFN 8L 2x2mm Green	2.3	2.3	1.05	4	4	1.55	1.75	3.5	8

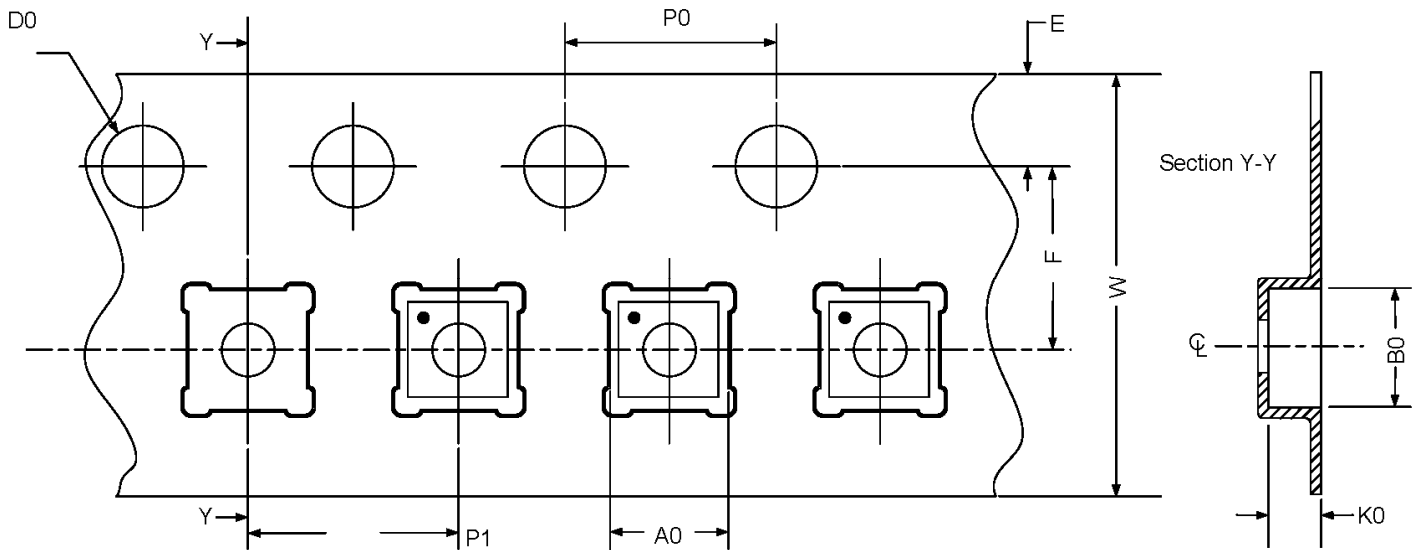

Recommended Reflow Soldering Profile

Please see IPC/JEDEC J-STD-020: latest revision for reflow profile based on package volume of 4.6875 mm³ (nominal). More information can be found at www.jedec.org.



Datasheet Revision History

Date	Version	Change
02/08/2012	0.1	New Design
06/05/2012	0.11	Changed name of design to "1Hz Interrupt Generator"
03/08/2013	0.12	Updated Device Revision Table
03/18/2013	0.13	Corrected Timing Diagrams
03/25/2013	0.14	Updated Device Revision Table



Silego Website & Support

Silego Technology Website

Silego Technology provides online support via our website at <http://www.silego.com/>. This website is used as a means to make files and information easily available to customers.

For more information regarding Silego Green products, please visit:

<http://greenpak.silego.com/>
<http://greenpak2.silego.com/>
<http://greenfet.silego.com/>
<http://greenfet2.silego.com/>
<http://greenclk.silego.com/>

Products are also available for purchase directly from Silego at the Silego Online Store at <http://store.silego.com/>.

Silego Technical Support

Datasheets and errata, application notes and example designs, user guides, and hardware support documents and the latest software releases are available at the Silego website or can be requested directly at info@silego.com.

For specific GreenPAK design or applications questions and support please send email requests to GreenPAK@silego.com

Users of Silego products can receive assistance through several channels:

Contact Your Local Sales Representative

Customers can contact their local sales representative or field application engineer (FAE) for support. Local sales offices are also available to help customers. More information regarding your local representative is available at the Silego website or send a request to info@silego.com

Contact Silego Directly

Silego can be contacted directly via e-mail at info@silego.com or user submission form, located at the following URL: <http://support.silego.com/>

Other Information

The latest Silego Technology press releases, listing of seminars and events, listings of world wide Silego Technology offices and representatives are all available at <http://www.silego.com/>

THIS PRODUCT HAS BEEN DESIGNED AND QUALIFIED FOR THE CONSUMER MARKET. APPLICATIONS OR USES AS CRITICAL COMPONENTS IN LIFE SUPPORT DEVICES OR SYSTEMS ARE NOT AUTHORIZED. SILEGO TECHNOLOGY DOES NOT ASSUME ANY LIABILITY ARISING OUT OF SUCH APPLICATIONS OR USES OF ITS PRODUCTS. SILEGO TECHNOLOGY RESERVES THE RIGHT TO IMPROVE PRODUCT DESIGN, FUNCTIONS AND RELIABILITY WITHOUT NOTICE.

X-ON Electronics

Largest Supplier of Electrical and Electronic Components

Click to view similar products for [CPLD - Complex Programmable Logic Devices](#) category:

Click to view products by [Silego](#) manufacturer:

Other Similar products are found below :

[5962-9759901QZC](#) [EPM7064LC68-7](#) [XC95288XL-10CS280I](#) [LC5512MV-45F256C](#) [ISPLSI2096A-80LT128I](#) [M4A3-512/160-14YI](#) [M4A5-192/96-10VC](#) [M5-320/160-12YC](#) [CY37032VP44-100AXC](#) [CY37064P44-154JI](#) [CY37064VP100-143AXC](#) [CY37128P84-100JXC](#) [ISPLSI2032A-135LJ44I](#) [LC4128V-27T128C](#) [CY37512P208-125NXC](#) [EPM1270T144C5N](#) [M5LV-256/68-7YC](#) [M5LV-256/104-10VI](#) [M5-384/160-7YC](#) [M4A5-64/32-12VI](#) [M4A3-64/32-10VNC48](#) [M4A3-512/160-7YC](#) [M4A3-512/160-10YC](#) [M4A5-192/96-7VC](#) [M4A3-64/32-7VI48](#) [M4A3-64/32-55VC](#) [M4A3-32/32-7VC](#) [M4A3-256/160-10YC](#) [M4A3-256/128-7FAC](#) [M4A3-256/128-10YI](#) [M4-128N/64-12JC](#) [LC4256B-75FT256AC](#) [LC4256V-5FT256BI](#) [LC4256V-75FT256BC](#) [LC4256V-75FT256BI](#) [LC4384V-35T176C](#) [LC4512V-10FT256I](#) [LC4512V-5FT256C](#) [LC5512MB-45FN256C](#) [LC5512MV-75FN256I](#) [LC5768MV-75F484C](#) [ISPLSI 2032E-110LT48](#) [LC4032C-75T44C](#) [LC4064C-5TN44C](#) [LC4128ZE-7MN144CAH7](#) [LC4256V75T144E](#) [LC4512B-35FT256C](#) [LC4512V-5FT256I](#) [LC5256MB-5F256C](#) [LC5256MB-5FN256C](#)