



## PWROK GENERATOR AND STARTUP LATCHING CIRCUIT

### General Description

Silego SLG7NT4081 is a low power and small form device. The SoC is housed in a 2.5mm x 2.5mm TDFN package which is optimal for using with small devices.

### Features

- Low Power Consumption
- 3.3V Supply Voltage
- RoHS Compliant / Halogen-Free
- Pb-Free TDFN-12 Package

### Pin Configuration

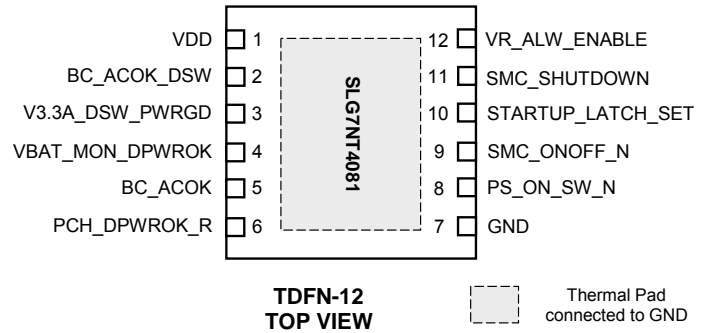

### Output Summary

- 2 Outputs – Push Pull
- 2 Outputs – Open Drain



### Block Diagram

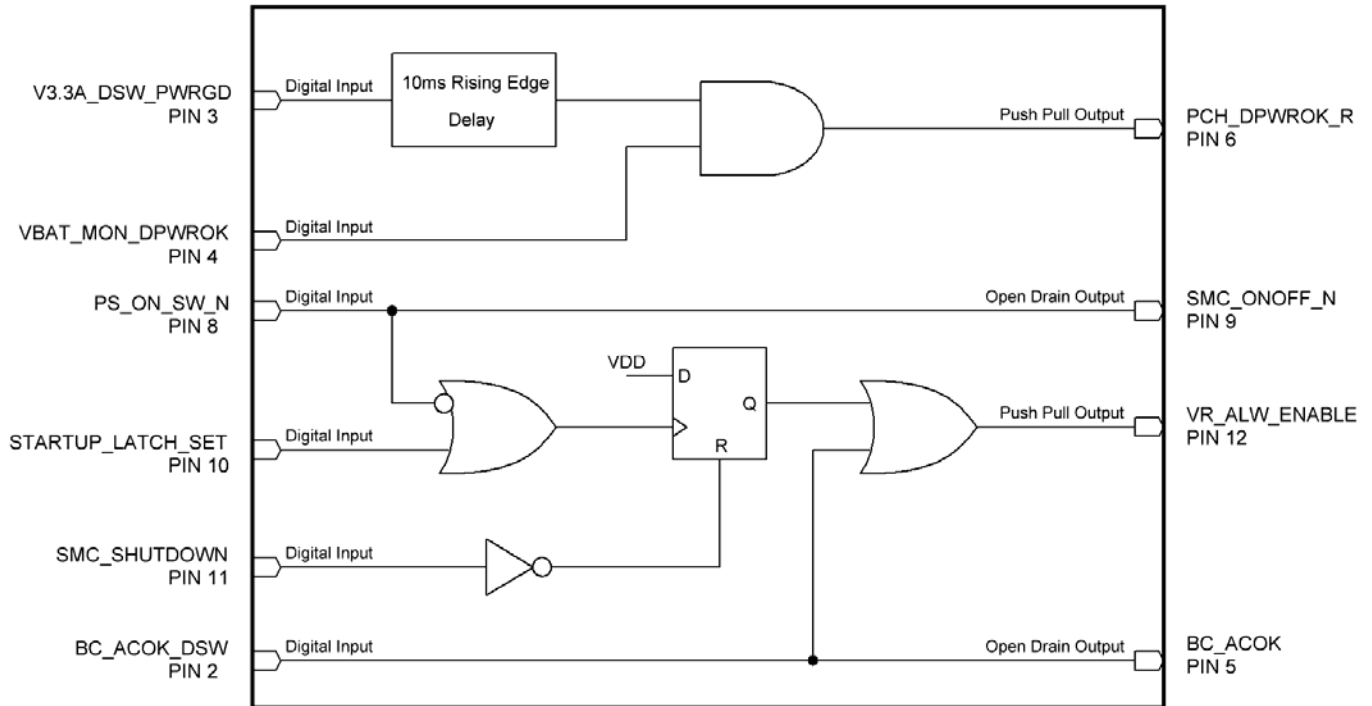

### Typical Application Circuit

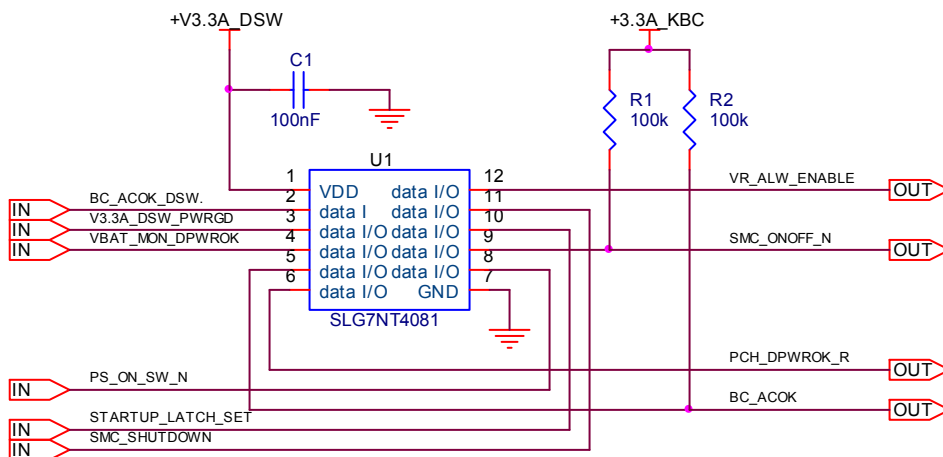



### Pin Configuration

Pin #	Pin Name	Type	Pin Description
1	VDD	PWR	Supply Voltage
2	BC_ACOK_DSW	Input	Digital Input
3	V3.3A_DSW_PWRGD	Input	Digital Input
4	VBAT_MON_DPWROK	Input	Digital Input
5	BC_ACOK	Output	Open Drain
6	PCH_DPWROK_R	Output	Push Pull
7	GND	GND	Ground
8	PS_ON_SW_N	Input	Digital Input
9	SMC_ONOFF_N	Output	Open Drain
10	STARTUP_LATCH_SET	Input	Digital Input
11	SMC_SHUTDOWN	Input	Digital Input
12	VR_ALW_ENABLE	Output	Push Pull
Exposed Bottom Pad	Exposed Bottom Pad	GND	Ground

### Ordering Information

Part Number	Package Type
SLG7NT4081V	V = TDFN-12
SLG7NT4081VTR	VTR = TDFN-12 - Tape and Reel (3k units)



### Absolute Maximum Conditions

Parameter	Min.	Max.	Unit
$V_{\text{HIGH}}$ to GND	-0.3	7	V
Voltage at input pins	-0.3	7	V
Current at input pin	-1.0	1.0	mA
Storage temperature range	-65	150	°C
Junction temperature	--	150	°C

### Electrical Characteristics

(@ 25°C, unless otherwise stated)

Symbol	Parameter	Condition/Note	Min.	Typ.	Max.	Unit
$V_{\text{DD}}$	Supply Voltage		3.0	3.3	3.6	V
$I_{\text{Q}}$	Quiescent Current	Static inputs and outputs	--	1	--	µA
$T_{\text{A}}$	Operating Temperature		-40	25	85	°C
$I_{\text{L}}$	Input Leakage Current	Leakage Current for Analog/Digital Inputs or outputs in High impedance state	-100	--	100	nA
$V_{\text{OH}}$	Output Voltage High	Push Pull Logic Level Output at $V_{\text{DD}}=3.3\text{V}$ , $I_{\text{OH}}=3\text{mA}$	2.1	--	--	V
$V_{\text{OL}}$	Output Voltage Low	Push Pull Logic Level Output at $V_{\text{DD}}=3.3\text{V}$ , $I_{\text{OL}}=3\text{mA}$	--	--	0.81	V
$V_{\text{OL}}$	Output Voltage Low	Open Drain Logic Level Output at $V_{\text{DD}}=3.3\text{V}$ , $I_{\text{OL}}=10\text{mA}$	--	--	0.605	V
$V_{\text{O}}$	Maximal Voltage Applied to any PIN in High-Impedance State		--	--	$V_{\text{DD}}$	V
$V_{\text{IH}}$	HIGH-Level Input Voltage	Logic Input at $V_{\text{DD}}=3.3\text{V}$	1.8	--	--	V
$V_{\text{IL}}$	LOW-Level Input Voltage	Logic Input at $V_{\text{DD}}=3.3\text{V}$	--	--	1.1	V
$I_{\text{OL}}$	LOW-Level Output Current	Push Pull Current at, $V_{\text{OL}}=0.4\text{V}$	--	1	--	mA
$I_{\text{OL}}$	LOW-Level Output Current	Open Drain Current at $V_{\text{OL}}=0.4\text{V}$	--	7	--	mA
$T_{\text{DLY1}}$	Delay1 Time		10	--	20	ms
$T_{\text{SU}}$	Start up Time	After $V_{\text{DD}}$ reaches 1.6V	--	7	--	ms



### Timing Diagrams

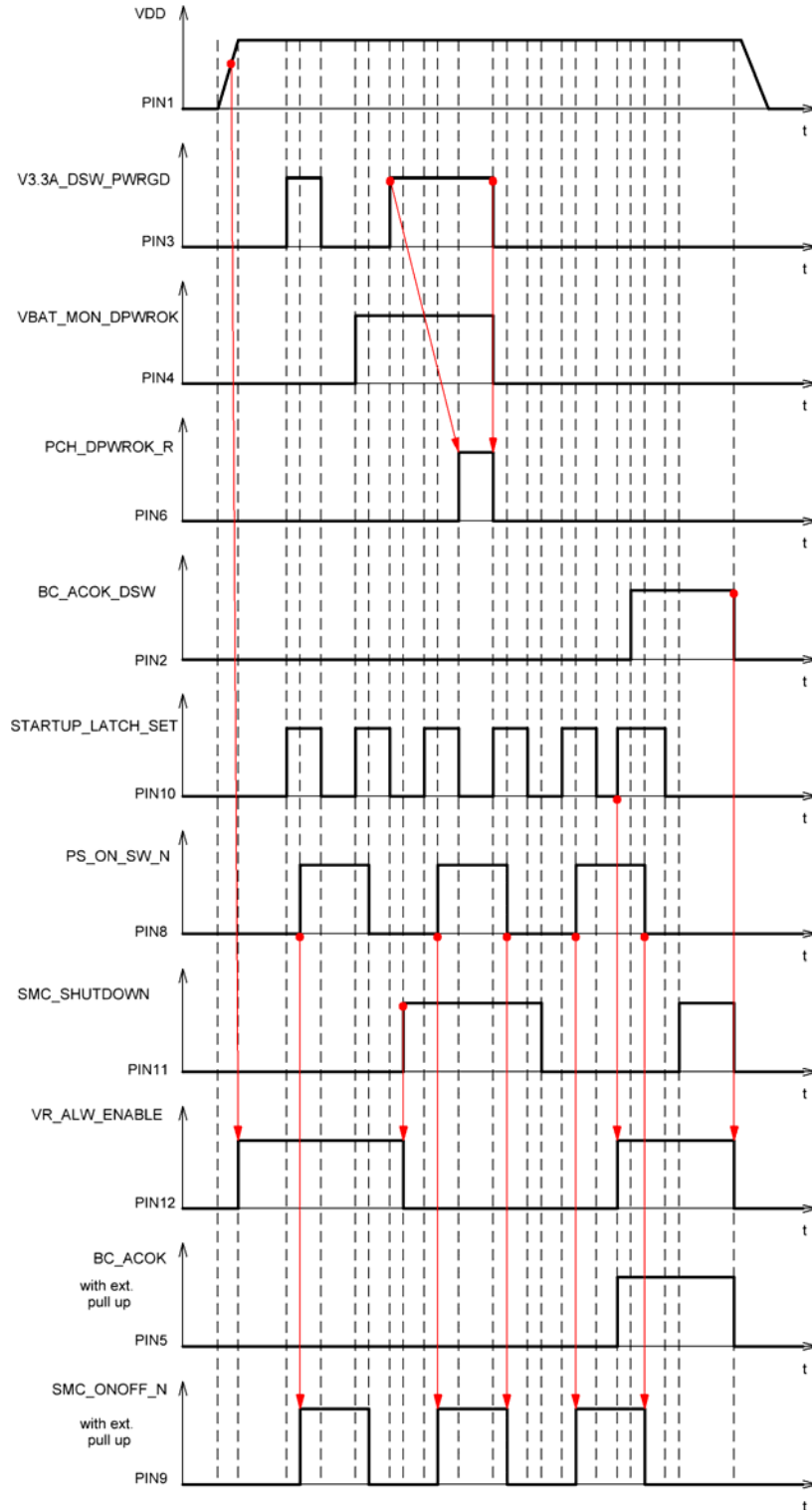



### Package Top Marking

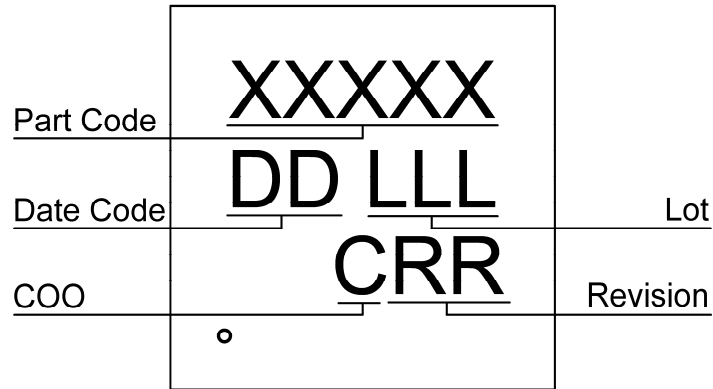

- XXXXX – Part Code Field: identifies the specific device configuration
- DD – Date Code Field: Coded date of manufacture
- LLL – Lot Code: Designates Lot #
- C – Assembly Site/COO: Specifies Assembly Site/Country of Origin
- RR – Revision Code: Device Revision

Datasheet Revision	Programming Code Number	Part Code	Revision	Date
1.03	05	4081V	AE	07/30/2013



### Package Drawing and Dimensions

#### 12 Lead TDFN Package JEDEC MO-229, Variation WDDE

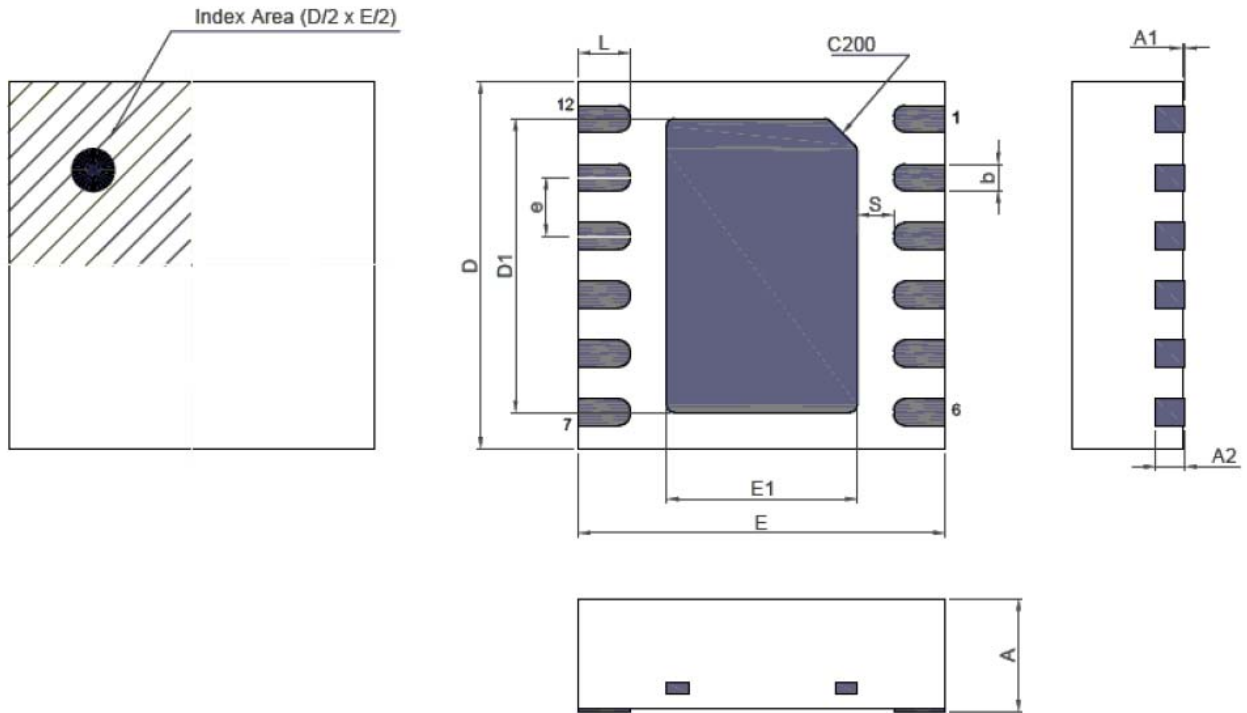

Unit: mm

Symbol	Min	Nom.	Max	Symbol	Min	Nom.	Max
A	0.70	0.75	0.80	D1	1.95	2.00	2.05
A1	0.005	-	0.060	E1	1.25	1.30	1.35
A2	0.15	0.20	0.25	e	0.40 BSC		
b	0.13	0.18	0.23	L	0.30	0.35	0.40
D	2.45	2.50	2.55	S	0.18	-	-
E	2.45	2.50	2.55				



### Tape and Reel Specification

Package Type	# of Pins	Nominal Package Size (mm)	Max Units		Reel & Hub Size (mm)	Trailer A		Leader B		Pocket (mm)	
			per reel	per box		Pockets	Length (mm)	Pockets	Length (mm)	Width	Pitch
TDFN 12L 2.5x2.5mm 0.4P Green	12	2.5x2.5x0.75	3000	3000	178/60	42	168	42	168	8	4

### Carrier Tape Drawing and Dimensions

Package Type	Pocket BTM Length (mm)	Pocket BTM Width (mm)	Pocket Depth (mm)	Index Hole Pitch (mm)	Pocket Pitch (mm)	Index Hole Diameter (mm)	Index Hole to Tape Edge (mm)	Index Hole to Pocket Center (mm)	Tape Width (mm)
	A0	B0	K0	P0	P1	D0	E	F	W
TDFN 12L 2.5x2.5mm 0.4P Green	2.75	2.75	1.05	4	4	1.55	1.75	3.5	8

Refer to EIA-481 Specifications

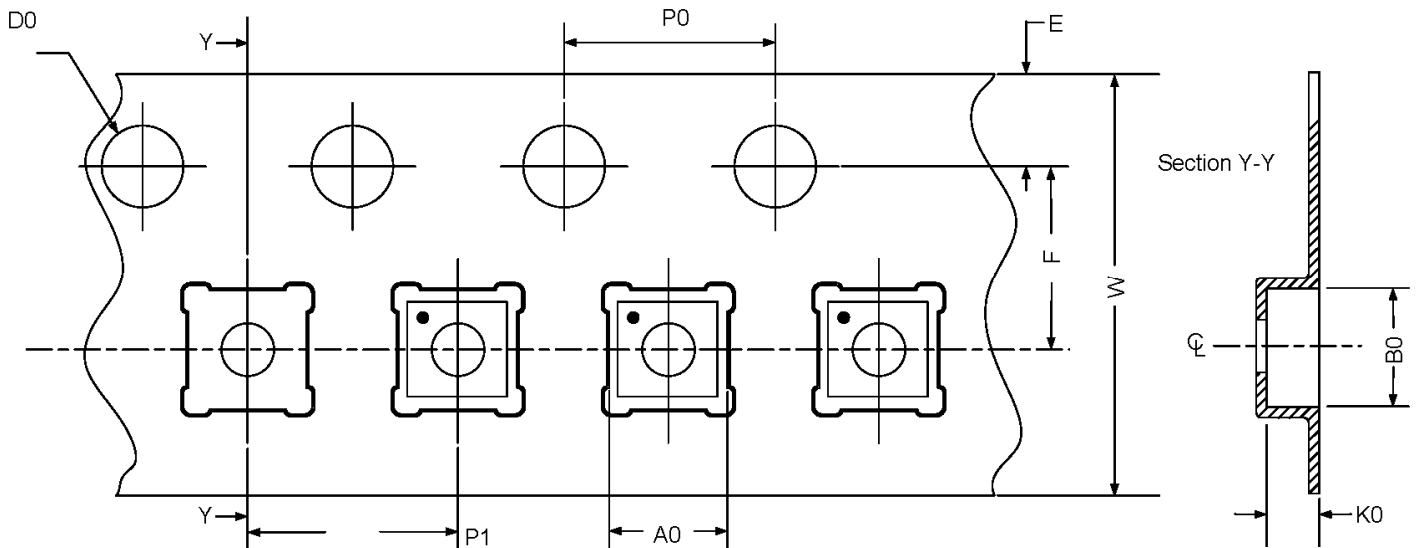

### Recommended Reflow Soldering Profile

Please see IPC/JEDEC J-STD-020: latest revision for reflow profile based on package volume of 4.6875 mm<sup>3</sup> (nominal). More information can be found at [www.jedec.org](http://www.jedec.org).





### Silego Website & Support

#### Silego Technology Website

Silego Technology provides online support via our website at <http://www.silego.com/>. This website is used as a means to make files and information easily available to customers.

For more information regarding Silego Green products, please visit:

<http://greenpak.silego.com/>  
<http://greenpak2.silego.com/>  
<http://greenfet.silego.com/>  
<http://greenfet2.silego.com/>  
<http://greenclock.silego.com/>

Products are also available for purchase directly from Silego at the Silego Online Store at <http://store.silego.com/>.

#### Silego Technical Support

Datasheets and errata, application notes and example designs, user guides, and hardware support documents and the latest software releases are available at the Silego website or can be requested directly at [info@silego.com](mailto:info@silego.com).

For specific GreenPAK design or applications questions and support please send email requests to [GreenPAK@silego.com](mailto:GreenPAK@silego.com)

Users of Silego products can receive assistance through several channels:

#### Contact Your Local Sales Representative

Customers can contact their local sales representative or field application engineer (FAE) for support. Local sales offices are also available to help customers. More information regarding your local representative is available at the Silego website or send a request to [info@silego.com](mailto:info@silego.com)

#### Contact Silego Directly

Silego can be contacted directly via e-mail at [info@silego.com](mailto:info@silego.com) or user submission form, located at the following URL: <http://support.silego.com/>

#### Other Information

The latest Silego Technology press releases, listing of seminars and events, listings of world wide Silego Technology offices and representatives are all available at <http://www.silego.com/>

THIS PRODUCT HAS BEEN DESIGNED AND QUALIFIED FOR THE CONSUMER MARKET. APPLICATIONS OR USES AS CRITICAL COMPONENTS IN LIFE SUPPORT DEVICES OR SYSTEMS ARE NOT AUTHORIZED. SILEGO TECHNOLOGY DOES NOT ASSUME ANY LIABILITY ARISING OUT OF SUCH APPLICATIONS OR USES OF ITS PRODUCTS. SILEGO TECHNOLOGY RESERVES THE RIGHT TO IMPROVE PRODUCT DESIGN, FUNCTIONS AND RELIABILITY WITHOUT NOTICE.

## X-ON Electronics

Largest Supplier of Electrical and Electronic Components

*Click to view similar products for [Power Management Specialised - PMIC category](#):*

*Click to view products by [Silego manufacturer](#):*

Other Similar products are found below :

[LV5686PVC-XH](#) [FAN7710VN](#) [NCP391FCALT2G](#) [SLG7NT4081VTR](#) [SLG7NT4192VTR](#) [AP4313UKTR-G1](#) [AS3729B-BWLM](#)  
[MB39C831QN-G-EFE2](#) [MAX4940MB](#) [LV56841PVD-XH](#) [MAX77686EWE+T](#) [AP4306BUKTR-G1](#) [MIC5164YMM](#) [PT8A3252WE](#)  
[NCP392CSFCCT1G](#) [TEA1998TS/1H](#) [PT8A3284WE](#) [PI3VST01ZEEX](#) [PI5USB1458AZAEX](#) [PI5USB1468AZAEX](#) [MCP16502TAC-E/S8B](#)  
[MCP16502TAE-E/S8B](#) [MCP16502TAA-E/S8B](#) [MCP16502TAB-E/S8B](#) [ISL91211AIKZT7AR5874](#) [ISL91211BIKZT7AR5878](#)  
[MAX17506EVKITBE#](#) [MCP16501TC-E/RMB](#) [ISL91212AIIZ-TR5770](#) [ISL91212BIIZ-TR5775](#) [CPX200D](#) [TP-1303](#) [TP-1305](#) [TP-1603](#) [TP-](#)  
[2305](#) [TP-30102](#) [TP-4503N](#) [MIC5167YML-TR](#) [LPTM21-1AFTG237C](#) [MPS-3003L-3](#) [MPS-3005D](#) [NCP392ARFCCT1G](#) [SPD-3606](#)  
[MMPF0200F6AEP](#) [STLUX383A](#) [TP-60052](#) [ADN8834ACBZ-R7](#) [LM26480SQ-AA/NOPB](#) [LM81BIMTX-3/NOPB](#) [LM81CIMT-3/NOPB](#)