



VR Enable and Discharge

General Description

Silego SLG7NT4100 is a low power and small form device. The SoC is housed in a 2.5mm x 2.5mm TDFN package which is optimal for using with small devices.

Features

- Low Power Consumption
- 3.3V Supply Voltage
- RoHS Compliant / Halogen-Free
- Pb-Free TDFN-12 Package

Pin Configuration

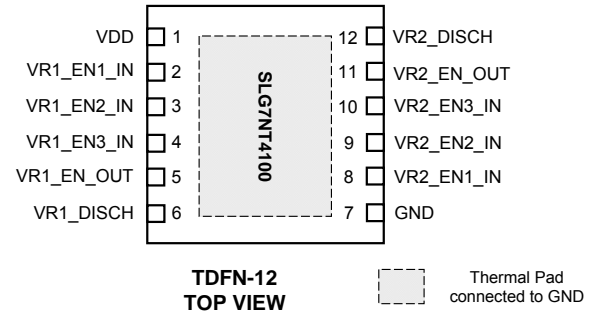

Output Summary

- 2 Outputs – Open Drain 2X current
- 2 Outputs – Push Pull



Block Diagram

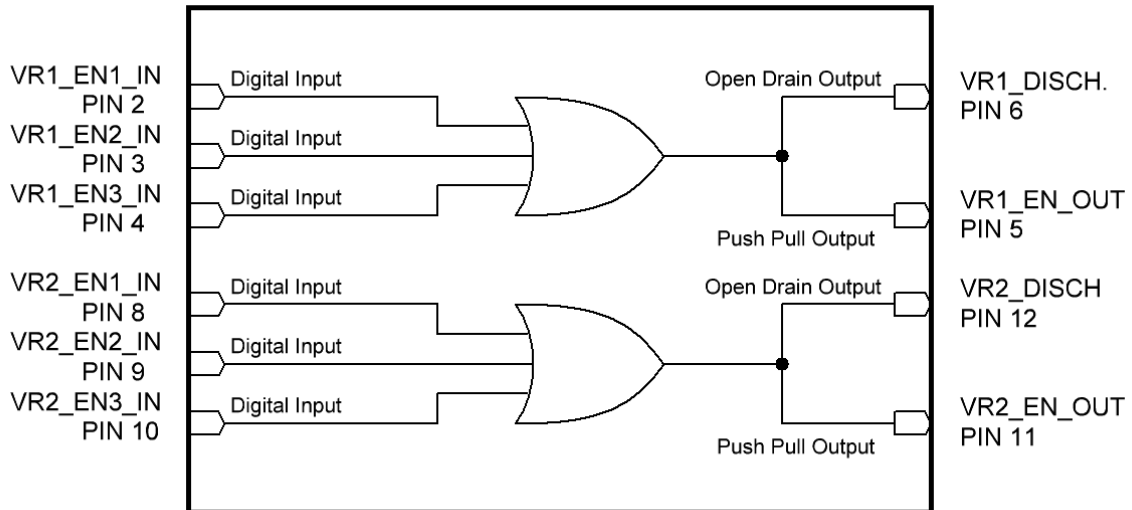

Typical Application Circuit

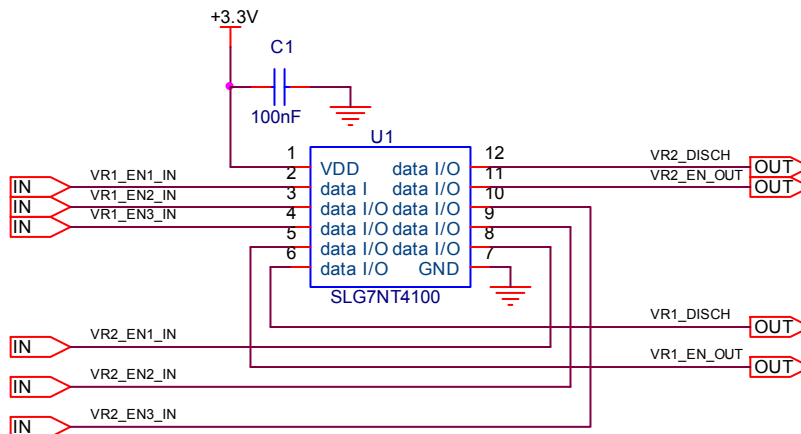



Pin Configuration

Pin #	Pin Name	Type	Pin Description
1	VDD	Power	Supply Voltage
2	VR1_EN1_IN	Input	Digital Input
3	VR1_EN2_IN	Input	Digital Input
4	VR1_EN3_IN	Input	Digital Input
5	VR1_EN_OUT	Output	Push Pull
6	VR1_DISCH	Output	Open Drain 2x current
7	GND	GND	Ground
8	VR2_EN1_IN	Input	Digital Input
9	VR2_EN2_IN	Input	Digital Input
10	VR2_EN3_IN	Input	Digital Input
11	VR2_EN_OUT	Output	Push Pull
12	VR2_DISCH	Output	Open Drain 2x current
Exposed Bottom Pad	Exposed Bottom Pad	GND	Ground

Ordering Information

Part Number	Package Type
SLG7NT4100V	V = TDFN-12
SLG7NT4100VTR	VTR = TDFN-12 - Tape and Reel (3k units)



Absolute Maximum Conditions

Parameter	Min.	Max.	Unit
V_{HIGH} to GND	-0.3	7	V
Voltage at input pins	-0.3	7	V
Current at input pin	-1.0	1.0	mA
Storage temperature range	-65	150	°C
Junction temperature	--	150	°C

Electrical Characteristics

(@ 25°C, unless otherwise stated)

Symbol	Parameter	Condition/Note	Min.	Typ.	Max.	Unit
V_{DD}	Supply Voltage		3.0	3.3	3.6	V
I_{Q}	Quiescent Current	Static inputs and outputs	--	1	--	μA
T_{A}	Operating Temperature		-40	25	85	°C
I_{L}	Input Leakage Current	Leakage Current for Digital Inputs or outputs in High impedance state	-100	--	100	nA
V_{IH}	HIGH-Level Input Voltage	Logic Input at $V_{\text{DD}}=3.3\text{V}$	1.8	--	--	V
V_{IL}	LOW-Level Input Voltage	Logic Input at $V_{\text{DD}}=3.3\text{V}$	--	--	1.1	V
V_{OH}	Output Voltage High	Push Pull Logic Level Output at $V_{\text{DD}}=3.3\text{V}$, $I_{\text{OH}}=3\text{mA}$	2.1	--	--	V
V_{OL}	Output Voltage Low	Push Pull Logic Level Output at $V_{\text{DD}}=3.3\text{V}$, $I_{\text{OL}}=3\text{mA}$	--	--	0.81	V
V_{OL}	Output Voltage Low	Open Drain Logic Level Output at $V_{\text{DD}}=3.3\text{V}$, $I_{\text{OL}}=10\text{mA}$, 2X Drive	--	--	0.252	V
V_{O}	Maximal Voltage Applied to any PIN in High-Impedance State		--	--	V_{DD}	V
I_{OL}	LOW-Level Output Current	Push Pull Current at, $V_{\text{OL}}=0.4\text{V}$	--	1	--	mA
I_{OL}	LOW-Level Output Current	Open Drain Current at $V_{\text{OL}}=0.4\text{V}$, 2X Drive	28	--	--	mA
T_{SU}	Start up Time	After V_{DD} reaches 1.6V	--	7	--	ms



Timing Diagrams

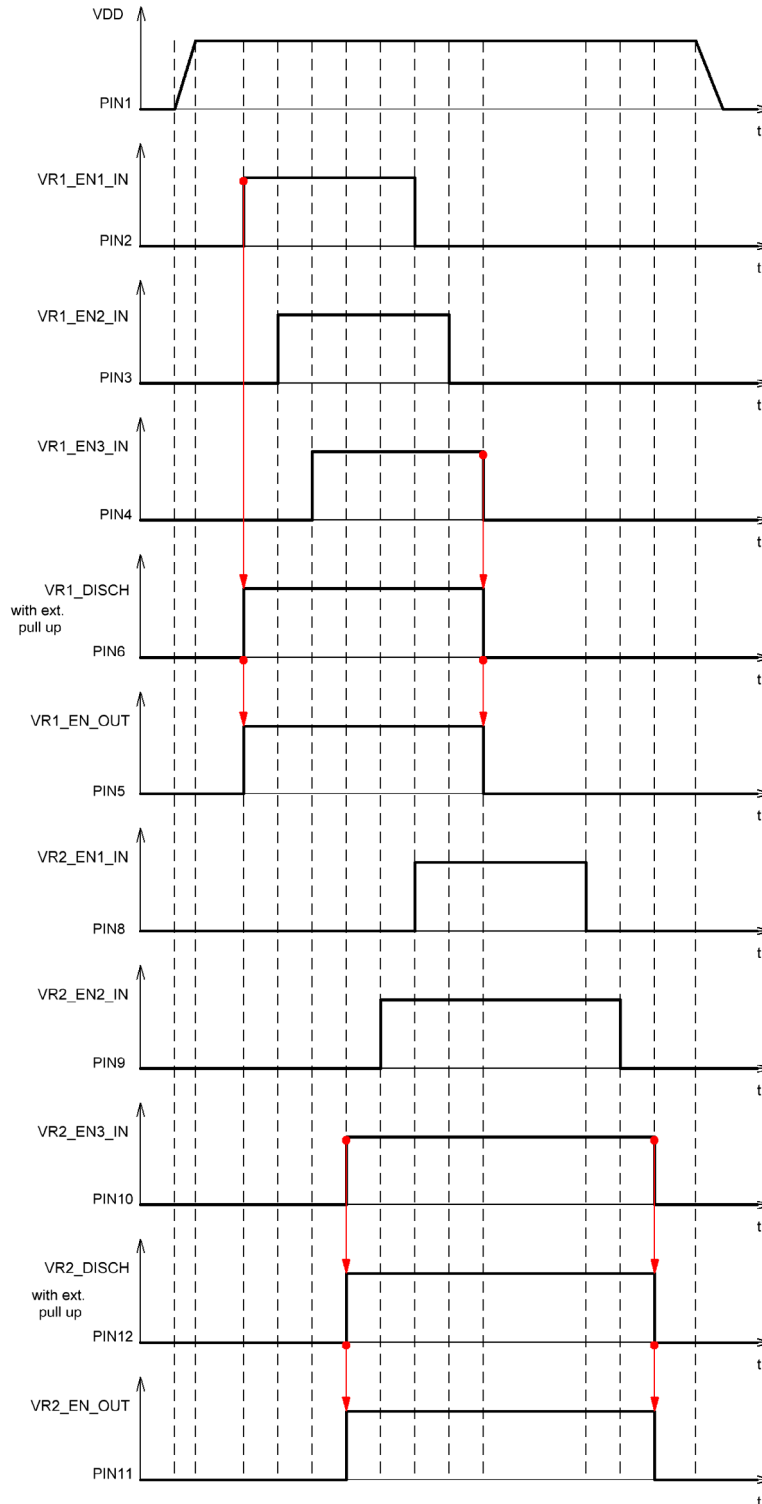



Package Top Marking

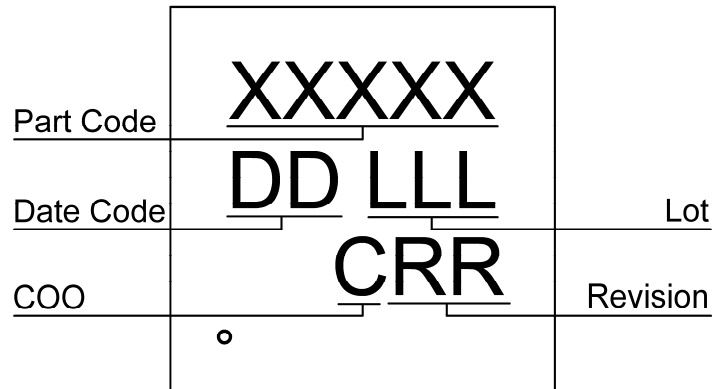

- XXXXX – Part Code Field: identifies the specific device configuration
- DD – Date Code Field: Coded date of manufacture
- LLL – Lot Code: Designates Lot #
- C – Assembly Site/COO: Specifies Assembly Site/Country of Origin
- RR – Revision Code: Device Revision

Datasheet Revision	Programming Code Number	Part Code	Revision	Date
1.01	02	4100V	AB	12/11/2012



Package Drawing and Dimensions

12 Lead TDFN Package
JEDEC MO-229, Variation WDDE



Unit: mm

Symbol	Min	Nom.	Max	Symbol	Min	Nom.	Max
A	0.70	0.75	0.80	D1	1.95	2.00	2.05
A1	0.005	-	0.060	E1	1.25	1.30	1.35
A2	0.15	0.20	0.25	e	0.40 BSC		
b	0.13	0.18	0.23	L	0.30	0.35	0.40
D	2.45	2.50	2.55	S	0.18	-	-
E	2.45	2.50	2.55				



Tape and Reel Specification

Package Type	# of Pins	Nominal Package Size (mm)	Max Units		Reel & Hub Size (mm)	Trailer A		Leader B		Pocket (mm)	
			per reel	per box		Pockets	Length (mm)	Pockets	Length (mm)	Width	Pitch
TDFN 12L 2.5x2.5mm 0.4P Green	12	2.5x2.5x0.75	3000	3000	178/60	42	168	42	168	8	4

Carrier Tape Drawing and Dimensions

Package Type	Pocket BTM Length (mm)	Pocket BTM Width (mm)	Pocket Depth (mm)	Index Hole Pitch (mm)	Pocket Pitch (mm)	Index Hole Diameter (mm)	Index Hole to Tape Edge (mm)	Index Hole to Pocket Center (mm)	Tape Width (mm)
	A0	B0	K0	P0	P1	D0	E	F	W
TDFN 12L 2.5x2.5mm 0.4P Green	2.75	2.75	1.05	4	4	1.55	1.75	3.5	8

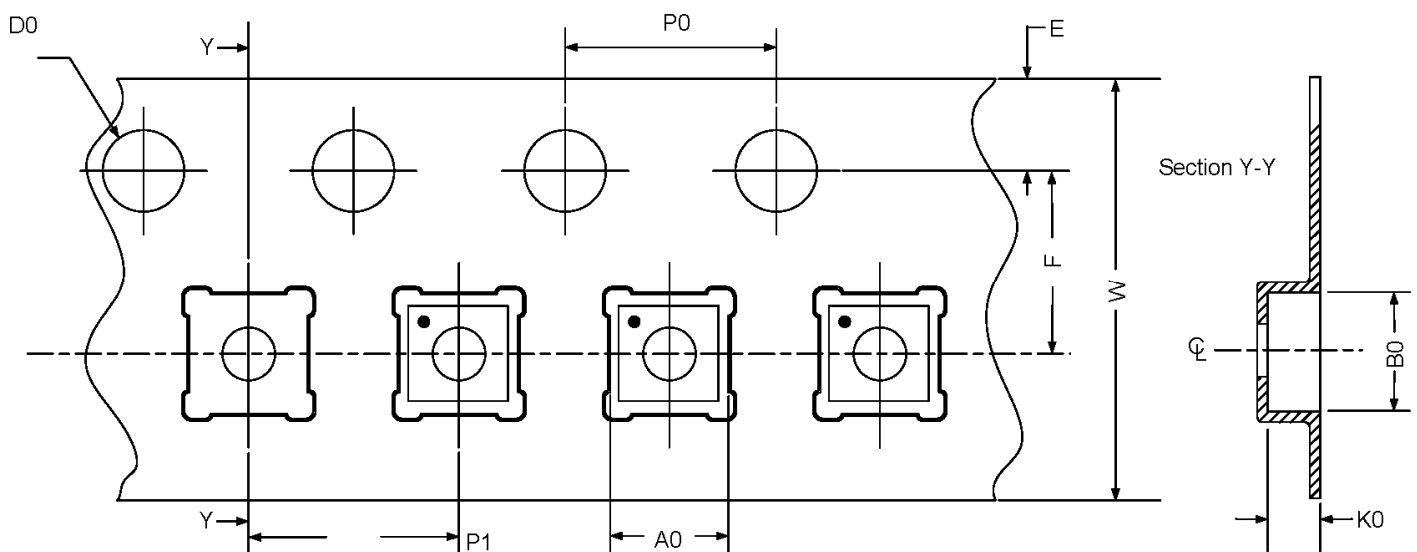

Recommended Reflow Soldering Profile

Please see IPC/JEDEC J-STD-020: latest revision for reflow profile based on package volume of 4.6875 mm³ (nominal). More information can be found at www.jedec.org.



Silego Website & Support

Silego Technology Website

Silego Technology provides online support via our website at <http://www.silego.com/>. This website is used as a means to make files and information easily available to customers.

For more information regarding Silego Green products, please visit:

<http://greenpak.silego.com/>
<http://greenpak2.silego.com/>
<http://greenfet.silego.com/>
<http://greenfet2.silego.com/>
<http://greenclock.silego.com/>

Products are also available for purchase directly from Silego at the Silego Online Store at <http://store.silego.com/>.

Silego Technical Support

Datasheets and errata, application notes and example designs, user guides, and hardware support documents and the latest software releases are available at the Silego website or can be requested directly at info@silego.com.

For specific GreenPAK design or applications questions and support please send email requests to GreenPAK@silego.com

Users of Silego products can receive assistance through several channels:

Online Live Support

Silego Technology has live video technical assistance and sales support available at <http://www.silego.com/>. Please ask our live web receptionist to schedule a 1 on 1 training session with one of our application engineers.

Contact Your Local Sales Representative

Customers can contact their local sales representative or field application engineer (FAE) for support. Local sales offices are also available to help customers. More information regarding your local representative is available at the Silego website or send a request to info@silego.com

Contact Silego Directly

Silego can be contacted directly via e-mail at info@silego.com or user submission form, located at the following URL: <http://support.silego.com/>

Other Information

The latest Silego Technology press releases, listing of seminars and events, listings of world wide Silego Technology offices and representatives are all available at <http://www.silego.com/>

THIS PRODUCT HAS BEEN DESIGNED AND QUALIFIED FOR THE CONSUMER MARKET. APPLICATIONS OR USES AS CRITICAL COMPONENTS IN LIFE SUPPORT DEVICES OR SYSTEMS ARE NOT AUTHORIZED. SILEGO TECHNOLOGY DOES NOT ASSUME ANY LIABILITY ARISING OUT OF SUCH APPLICATIONS OR USES OF ITS PRODUCTS. SILEGO TECHNOLOGY RESERVES THE RIGHT TO IMPROVE PRODUCT DESIGN, FUNCTIONS AND RELIABILITY WITHOUT NOTICE.

X-ON Electronics

Largest Supplier of Electrical and Electronic Components

Click to view similar products for [Power Management Specialised - PMIC category](#):

Click to view products by [Silego manufacturer](#):

Other Similar products are found below :

[LV5686PVC-XH](#) [FAN7710VN](#) [NCP391FCALT2G](#) [SLG7NT4081VTR](#) [SLG7NT4192VTR](#) [AP4313UKTR-G1](#) [AS3729B-BWLM](#)
[MB39C831QN-G-EFE2](#) [MAX4940MB](#) [LV56841PVD-XH](#) [MAX77686EWE+T](#) [AP4306BUKTR-G1](#) [MIC5164YMM](#) [PT8A3252WE](#)
[NCP392CSFCCT1G](#) [TEA1998TS/1H](#) [PT8A3284WE](#) [PI3VST01ZEEX](#) [PI5USB1458AZAEX](#) [PI5USB1468AZAEX](#) [MCP16502TAC-E/S8B](#)
[MCP16502TAE-E/S8B](#) [MCP16502TAA-E/S8B](#) [MCP16502TAB-E/S8B](#) [ISL91211AIKZT7AR5874](#) [ISL91211BIKZT7AR5878](#)
[MAX17506EVKITBE#](#) [MCP16501TC-E/RMB](#) [ISL91212AIIZ-TR5770](#) [ISL91212BIIZ-TR5775](#) [CPX200D](#) [TP-1303](#) [TP-1305](#) [TP-1603](#) [TP-](#)
[2305](#) [TP-30102](#) [TP-4503N](#) [MIC5167YML-TR](#) [LPTM21-1AFTG237C](#) [MPS-3003L-3](#) [MPS-3005D](#) [NCP392ARFCCT1G](#) [SPD-3606](#)
[MMPF0200F6AEP](#) [STLUX383A](#) [TP-60052](#) [ADN8834ACBZ-R7](#) [LM26480SQ-AA/NOPB](#) [LM81BIMTX-3/NOPB](#) [LM81CIMT-3/NOPB](#)