



General Description

Silego GreenPAK 2 SLG7NT4204 is a low power and small form device. The SoC is housed in a 2.5mm x 2.5mm TDFN package which is optimal for using with small devices.

Features

- Low Power Consumption
- +3.3V Supply Voltage
- RoHS Compliant / Halogen-Free
- Pb-Free TDFN-12 Package

Pin Configuration

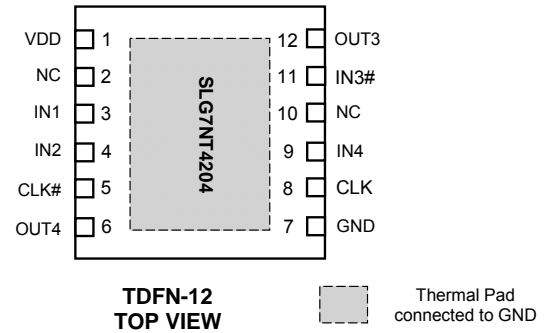

Output Summary

- 4 Outputs – Push Pull



Pin Configuration

Pin #	Pin Name	Type	Pin Description
1	VDD	PWR	Supply Voltage
2	NC	--	Keep floating or connect to GND
3	IN1	Input	Analog Input
4	IN2	Input	Analog Input
5	CLK#	Output	Push Pull
6	OUT4	Output	Push Pull
7	GND	GND	Ground
8	CLK	Output	Push Pull
9	IN4	Input	Digital Input
10	NC	--	Keep floating or connect to GND
11	IN3#	Input	Digital Input
12	OUT3	Output	Push Pull
Exposed Bottom Pad	Exposed Bottom Pad	GND	Ground

Ordering Information

Part Number	Package Type
SLG7NT4204V	V = TDFN-12
SLG7NT4204VTR	VTR = TDFN-12 - Tape and Reel (3k units)



Absolute Maximum Conditions

Parameter	Min.	Max.	Unit
V _{HIGH} to GND	-0.3	7	V
Voltage at input pins	-0.3	7	V
Current at input pin	-1.0	1.0	mA
Storage temperature range	-65	150	°C
Junction temperature	--	150	°C

Electrical Characteristics

(@ 25°C, unless otherwise stated)

Symbol	Parameter	Condition/Note	Min.	Typ.	Max.	Unit
V _{DD}	Supply Voltage		3.0	3.3	3.6	V
I _Q	Quiescent Current	Static inputs and outputs	--	80	--	µA
T _A	Operating Temperature		-40	25	85	°C
I _L	Input Leakage Current	Leakage Current for Digital Inputs or outputs in High impedance state	-1	--	1	µA
V _{IH}	HIGH-Level Input Voltage	Logic Input	1.8			V
V _{IL}	LOW-Level Input Voltage	Logic Input			1.1	V
I _{IH}	HIGH-Level Input Current	Logic Input Pins; V _{IN} =VDD	-1		1	µA
I _{IL}	LOW-Level Input Current	Logic Input Pins; V _{IN} =0V	-1		1	µA
T _{DLY0}	Delay0 Time		85.85	101	116.15	ms
T _{DLY1}	Delay1 Time		8.5	10	11.5	ms
T _{DLY2}	Delay2 Time		8.5	10	11.5	ms
T _{DLY3}	Delay3 Time		0.85	1	1.15	ms
V _{OH}	Output Voltage High	Push Pull 1X Drive, I _{OH} = 3mA	2.1	--	--	V
V _{OL}	Output Voltage Low	Push Pull 1X Drive, I _{OL} = 3mA	--	--	0.81	V
V _O	Maximal Voltage Applied to any PIN in High-Impedance State		--	--	VDD	V
I _O	Maximal Average or DC Current	Per each chip side	--	--	24	mA
I _{OL}	LOW-Level Output Current	Push Pull 1X Drive, V _{OL} = 0.4V	1.836	--	--	mA
T _{SU}	Start up Time	After VDD reaches 1.6V level	--	7	--	ms



Timing Diagrams

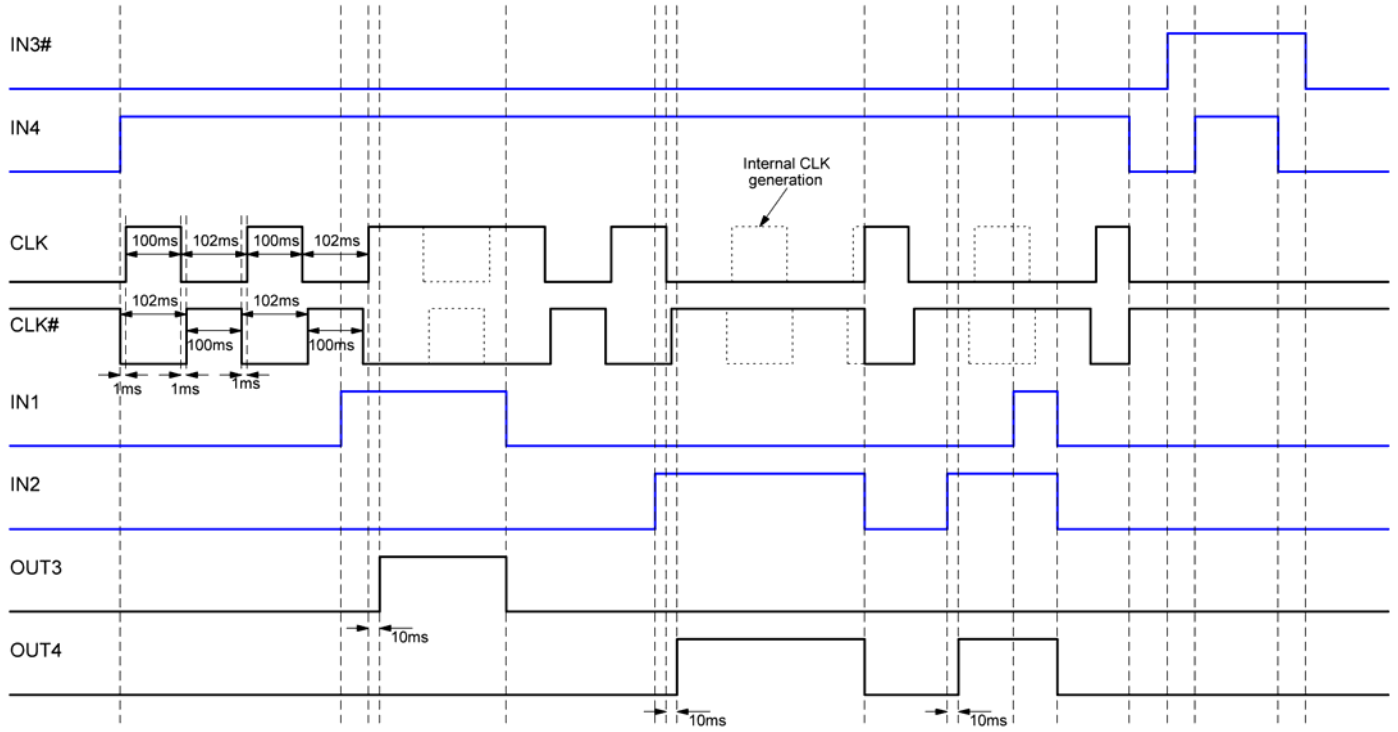



Typical Application Circuit

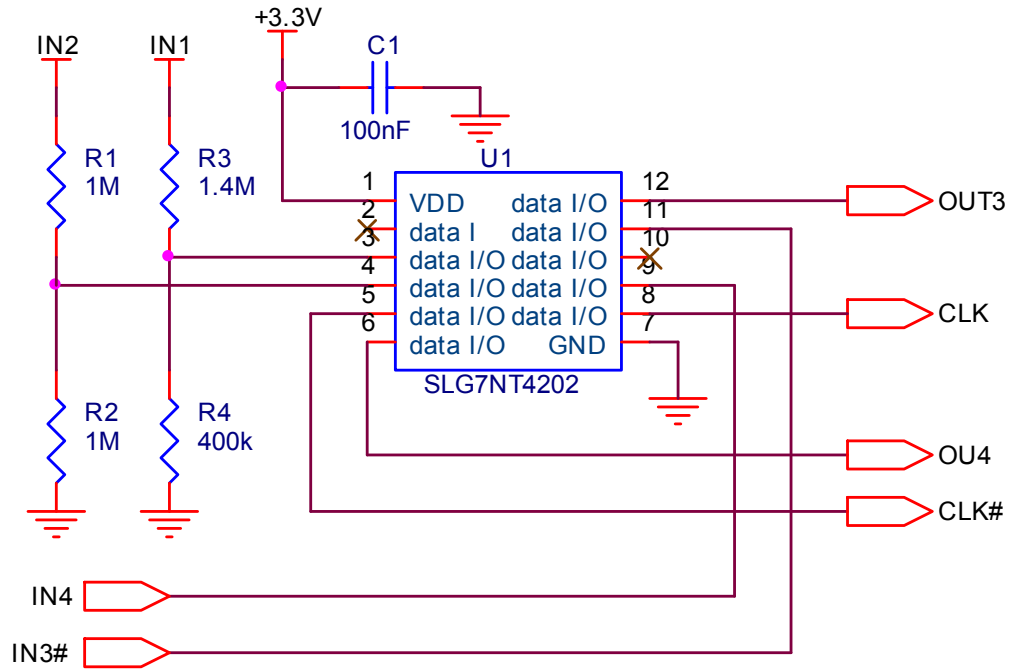



Package Top Marking

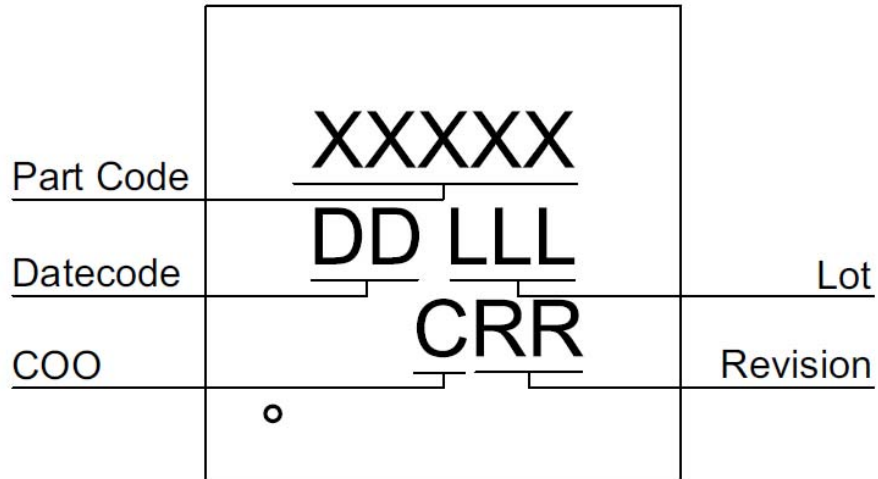

- XXXXXX – Part ID Field: identifies the specific device configuration
- DD – Date Code Field: Coded date of manufacture
- LLL – Lot Code: Designates Lot #
- C – COO: Specifies Country of Origin
- RR – Revision Code: Device Revision

Datasheet Revision	Programming Code Number	Part Code	Revision	Date
0.14	03	4204V	AA	07/18/2013



Package Drawing and Dimensions

12 Lead TDFN Package JEDEC MO-252, Variation 2525E

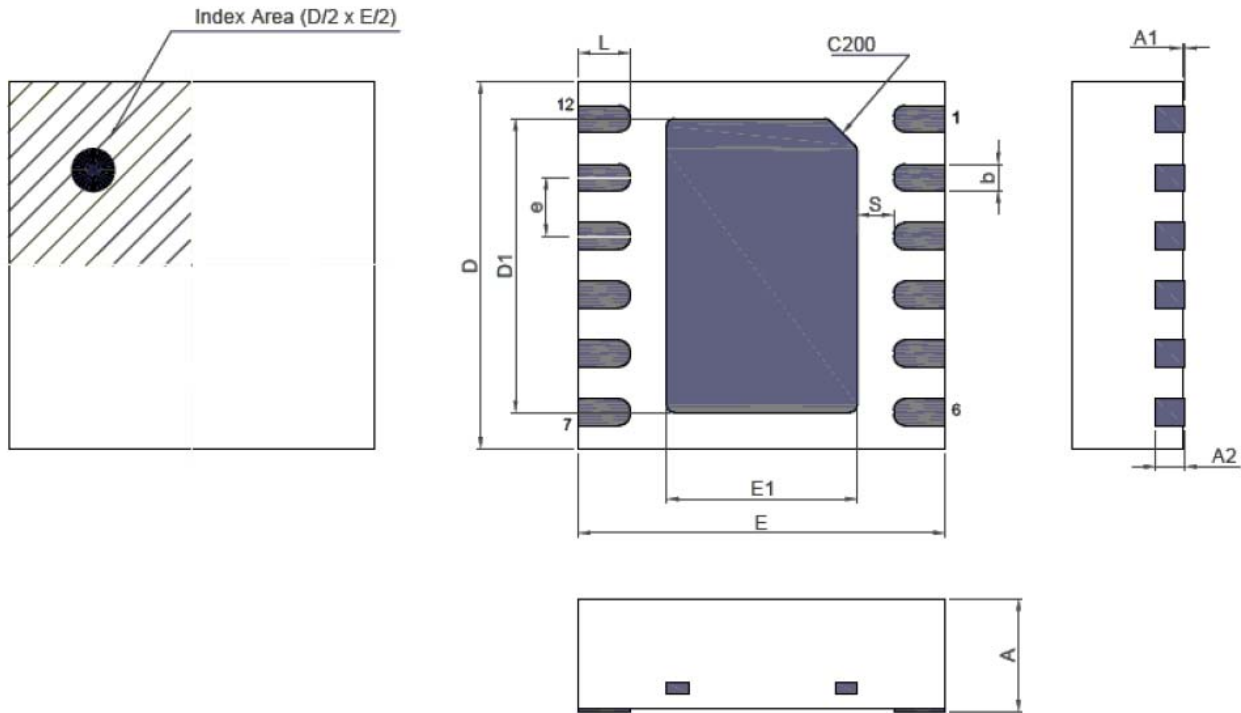

Unit: mm

Symbol	Min	Nom.	Max	Symbol	Min	Nom.	Max
A	0.70	0.75	0.80	D1	1.95	2.00	2.05
A1	0.005	-	0.060	E1	1.25	1.30	1.35
A2	0.15	0.20	0.25	e	0.40 BSC		
b	0.13	0.18	0.23	L	0.30	0.35	0.40
D	2.45	2.50	2.55	S	0.18	-	-
E	2.45	2.50	2.55				



Tape and Reel Specification

Package Type	# of Pins	Nominal Package Size (mm)	Max Units		Reel & Hub Size (mm)	Trailer A		Leader B		Pocket (mm)	
			per reel	per box		Pockets	Length (mm)	Pockets	Length (mm)	Width	Pitch
TDFN 12L 2.5x2.5mm 0.4P Green	12	2.5x2.5x0.75	3000	3000	178/60	42	168	42	168	8	4

Carrier Tape Drawing and Dimensions

Package Type	Pocket BTM Length (mm)	Pocket BTM Width (mm)	Pocket Depth (mm)	Index Hole Pitch (mm)	Pocket Pitch (mm)	Index Hole Diameter (mm)	Index Hole to Tape Edge (mm)	Index Hole to Pocket Center (mm)	Tape Width (mm)
	A0	B0	K0	P0	P1	D0	E	F	W
TDFN 12L 2.5x2.5mm 0.4P Green	2.75	2.75	1.05	4	4	1.55	1.75	3.5	8

Refer to EIA-481 Specifications

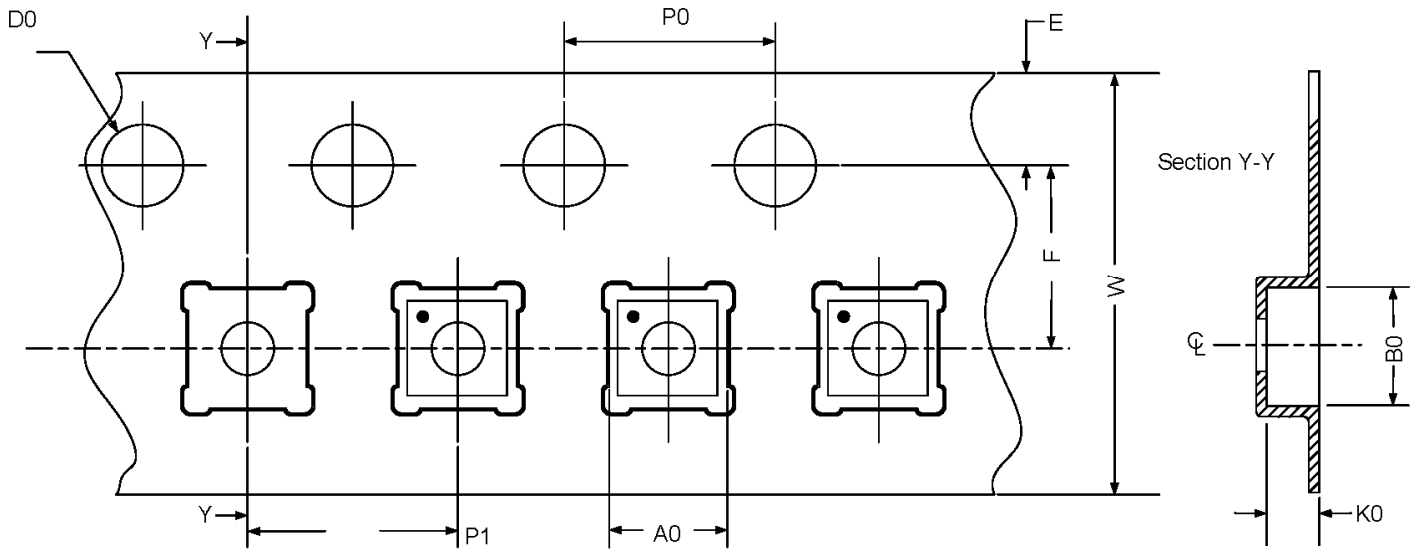

Recommended Reflow Soldering Profile

Please see IPC/JEDEC J-STD-020: latest revision for reflow profile based on package volume of 4.6875 mm³ (nominal). More information can be found at www.jedec.org.



Datasheet Revision History

Date	Version	Change
06/24/2013	0.11	New design datasheet
06/25/2013	0.12	Corrected device operation
06/26/2013	0.13	Corrected Timing Diagram
07/18/2013	0.14	Updated Device Revision Table



Silego Website & Support

Silego Technology Website

Silego Technology provides online support via our website at <http://www.silego.com/>. This website is used as a means to make files and information easily available to customers.

For more information regarding Silego Green products, please visit:

<http://greenpak.silego.com/>
<http://greenpak2.silego.com/>
<http://greenfet.silego.com/>
<http://greenfet2.silego.com/>
<http://greenclock.silego.com/>

Products are also available for purchase directly from Silego at the Silego Online Store at <http://store.silego.com/>.

Silego Technical Support

Datasheets and errata, application notes and example designs, user guides, and hardware support documents and the latest software releases are available at the Silego website or can be requested directly at info@silego.com.

For specific GreenPAK design or applications questions and support please send email requests to GreenPAK@silego.com

Users of Silego products can receive assistance through several channels:

Contact Your Local Sales Representative

Customers can contact their local sales representative or field application engineer (FAE) for support. Local sales offices are also available to help customers. More information regarding your local representative is available at the Silego website or send a request to info@silego.com

Contact Silego Directly

Silego can be contacted directly via e-mail at info@silego.com or user submission form, located at the following URL: <http://support.silego.com/>

Other Information

The latest Silego Technology press releases, listing of seminars and events, listings of world wide Silego Technology offices and representatives are all available at <http://www.silego.com/>

THIS PRODUCT HAS BEEN DESIGNED AND QUALIFIED FOR THE CONSUMER MARKET. APPLICATIONS OR USES AS CRITICAL COMPONENTS IN LIFE SUPPORT DEVICES OR SYSTEMS ARE NOT AUTHORIZED. SILEGO TECHNOLOGY DOES NOT ASSUME ANY LIABILITY ARISING OUT OF SUCH APPLICATIONS OR USES OF ITS PRODUCTS. SILEGO TECHNOLOGY RESERVES THE RIGHT TO IMPROVE PRODUCT DESIGN, FUNCTIONS AND RELIABILITY WITHOUT NOTICE.

X-ON Electronics

Largest Supplier of Electrical and Electronic Components

Click to view similar products for [Logic Gates](#) category:

Click to view products by [Silego](#) manufacturer:

Other Similar products are found below :

[74HC85N](#) [NLU1G32AMUTCG](#) [NLVHC1G08DFT1G](#) [CD4068BE](#) [NL17SG32P5T5G](#) [NL17SG86DFT2G](#) [NLV14001UBDR2G](#)
[NLX1G11AMUTCG](#) [NLX1G97MUTCG](#) [74LS38](#) [74LVC32ADTR2G](#) [MC74HCT20ADTR2G](#) [NLV17SZ00DFT2G](#) [NLV17SZ02DFT2G](#)
[NLV74HC02ADR2G](#) [74HC32S14-13](#) [74LS133](#) [M38510/30402BDA](#) [74LVC1G86Z-7](#) [74LVC2G08RA3-7](#) [NLV74HC08ADTR2G](#)
[NLV74HC14ADR2G](#) [NLV74HC20ADR2G](#) [NLX2G86MUTCG](#) [5962-8973601DA](#) [74LVC2G02HD4-7](#) [NLU1G00AMUTCG](#)
[74LVC2G32RA3-7](#) [74LVC2G00HD4-7](#) [NL17SG02P5T5G](#) [74LVC2G00HK3-7](#) [74LVC2G86HK3-7](#) [NLX1G99DMUTWG](#)
[NLVVHC1G00DFT2G](#) [NLVHC1G08DFT2G](#) [NLV7SZ57DFT2G](#) [NLV74VHC04DTR2G](#) [NLV27WZ86USG](#) [NLV27WZ00USG](#)
[NLU1G86CMUTCG](#) [NLU1G08CMUTCG](#) [NL17SZ32P5T5G](#) [NL17SZ00P5T5G](#) [NL17SH02P5T5G](#) [74AUP2G00RA3-7](#)
[NLV74HC02ADTR2G](#) [NLX1G332CMUTCG](#) [NL17SG86P5T5G](#) [NL17SZ05P5T5G](#) [NLV74VHC00DTR2G](#)