



Applications Note: SY5018B

Single Stage Flyback and PFC Controller with CV Control

Advanced Design Specification

General Description

SY5018B is a single stage Flyback and PFC controller targeting at Constant Voltage (CV) applications. Primary side control is applied to reduce the feedback circuit cost. It drives the Flyback converter in the Quasi-Resonant mode for high efficiency and achieves high power factor by constant on time control scheme. Adaptive PWM/PFM control is adopted for highest average efficiency.

Ordering Information

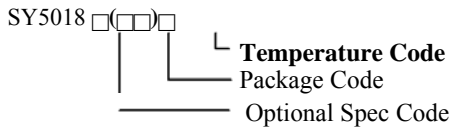

Ordering Number	Package type	Note
SY5018BFAC	SO8	----

Features

- Primary side CV control eliminates the opto-coupler.
- Valley turn-on of the primary MOSFET to achieve low switching losses
- Internal high current MOSFET driver: 0.1A sourcing and 0.5A sinking
- Power factor >0.90 with single-stage conversion
- Maximum switching frequency limitation 100kHz
- Compact package: SO8
- Output current limit, about 1.2 times the rated current

Applications

- AC/DC adapters
- Battery Chargers
- LED Lighting

Typical Applications

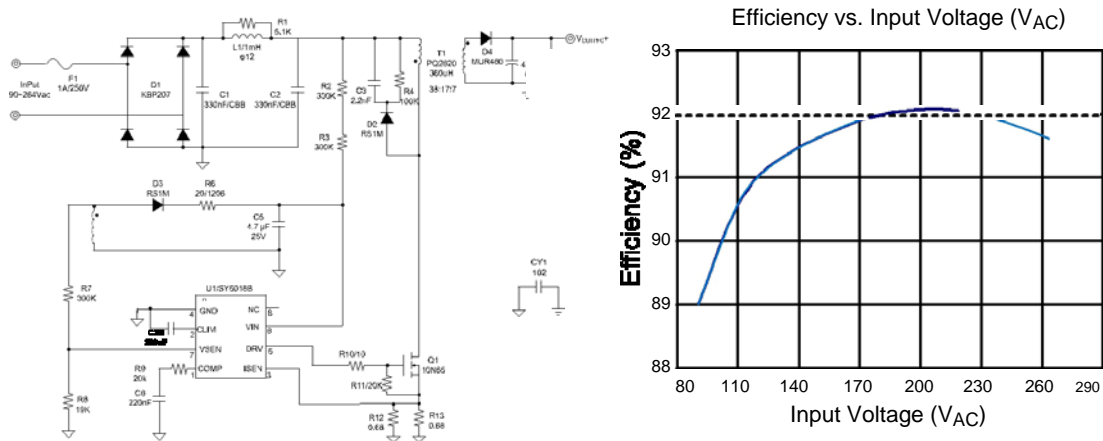
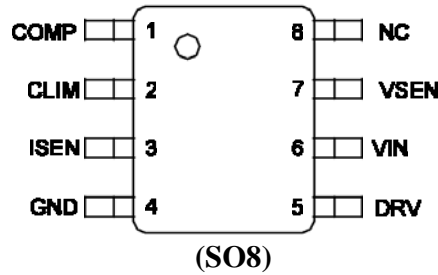

Figure 1. Schematic Diagram

Pinout (top view)



Top Mark: BEV xyz (device code: BEV, x=year code, y=week code, z=lot number code)

Pin	Name	Description
1	COMP	Loop compensation pin. Connect a RC network across this pin and ground to stabilize the control loop.
2	CLIM	Add 220nF ceramic capacitor to GND, output current will be limited to about 1.2 times the rated current. If do not need this function, connect CLIM PIN to GND.
3	ISEN	Current limit PIN.
4	GND	Ground pin.
5	DRV	Gate driver pin. Connect this pin to the gate of primary MOSFET with a resistor.
6	VIN	Power supply pin.
7	VSEN	Output voltage and inductor current zero detection PIN. This pin receives the auxiliary winding voltage by a resistor divider.

Block Diagram

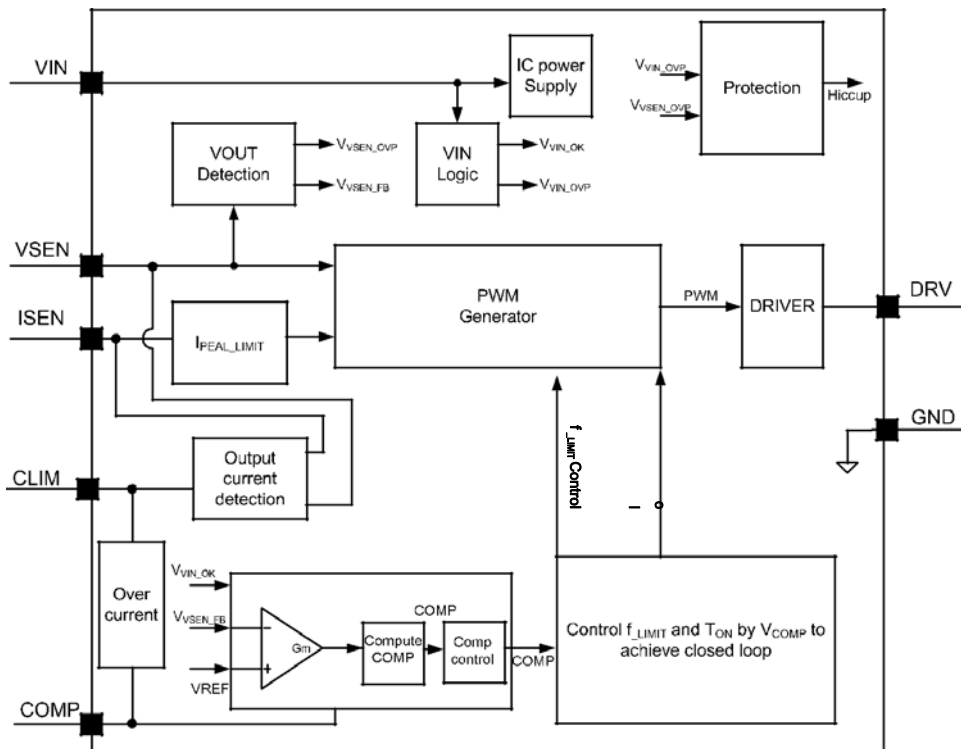



Absolute Maximum Ratings (Note 1)

VIN, DRV -----	-0.3V to 36V
Supply current I _{VIN} -----	20mA
VSEN -----	-0.3V to V _{IN} +0.3V
ISEN, COMP, CLIM-----	3.6V
Power Dissipation, @ T _A = 25°C SO8 -----	1.1W
Package Thermal Resistance (Note 2)	
SO8,θ _{JA} -----	88°C/W
SO8,θ _{JC} -----	45°C/W
Temperature Range -----	-40°C to 150°C
Lead Temperature (Soldering, 10 sec.) -----	260°C
Storage Temperature Range -----	-65°C to 150°C

Recommended Operating Conditions (Note 3)

VIN, DRV -----	9V~22V
Absolute maximum range-----	-40°C to 150°C



Electrical Characteristics

($V_{IN} = 12V$ (Note 3), $T_A = 25^\circ C$ unless otherwise specified)

Parameter	Symbol	Test Conditions	Min	Typ	Max	Unit
Power Supply Section						
Input voltage range	V_{VIN}		9		22	V
VIN turn-on threshold	V_{VIN_ON}			21.5		V
VIN turn-off threshold	V_{VIN_OFF}			7.5		V
VIN OVP voltage	V_{VIN_OVP}			24.5		V
Start up Current	I_{ST}	$V_{VIN} \rightarrow V_{VIN_OFF}$		5		μA
Operating Current	I_{VIN}	$C_L=100pF, f=15kHz$		1		mA
Shunt current in OVP mode	I_{VIN_OVP}	$V_{VIN} \rightarrow V_{VIN_OVP}$		2.5		mA
Error Amplifier Section						
Current limit Voltage	V_{ISEN_LIMIT}	$V_{SEN}<0.2V$		0.4		V
		$1.0V>V_{SEN}>0.2V$		1.0		V
Maximum Current Voltage	V_{ISEN_EX}			1.5		V
V_{FB} at fast start up	V_{FB_LOW}			1.0		V
Internal reference voltage	V_{REFV}			1.25		V
Threshold value of Max V_{FB}	V_{FB_HIGH}			1.40		V
OVP voltage threshold	V_{VSEN_OVP}			1.50		V
Blanking time for OFF time	t_{OFF_MIN1}	$V_{ISEN_HOLD} = -0.15V$		1.7		μs
		$V_{ISEN_HOLD} = -0.40V$		2.6		μs
Gate driver voltage	V_{Gate}			12		V
Typical source current	I_{SOURCE}			100		mA
Typical sink current	I_{SINK}			500		mA
Max ON Time	t_{ON_MAX}	$V_{comp}=2.5V$		10		μs
Min ON Time	t_{ON_MIN}			0.4		μs
Maximum switching frequency	f_{MAX}			100		kHz
Output current limit	V_{CLIM}			0.33		V
Thermal Section						
Thermal Shutdown Temperature	T_{SD}			150		$^\circ C$

Note 1: Stresses beyond the “Absolute Maximum Ratings” may cause permanent damage to the device. These are stress ratings only. Functional operation of the device at these or any other conditions beyond those indicated in the operational sections of the specification is not implied. Exposure to absolute maximum rating conditions for extended periods may affect device reliability.

Note 2: θ_{JA} is measured in the natural convection at $T_A = 25^\circ C$ on a low effective single layer thermal conductivity test board of JEDEC 51-3 thermal measurement standard. Test condition: Device mounted on 2” x 2” FR-4 substrate PCB, 2oz copper, with minimum recommended pad on top layer and thermal vias to bottom layer ground plane.

Note 3: Increase VIN pin voltage gradually higher than V_{VIN_ON} voltage then turn down to 12V.

Operation

SY5018B is a constant voltage Flyback controller with primary side control and PFC function that targets at LED lighting applications.

The Device provides primary side control to eliminate the opto-couplers or the secondary feedback circuits, which would cut down the cost of the system.

High power factor is achieved by constant on operation mode, with which the control scheme and the circuit structure are both simple.

Start up process is optimized inside SY5018B, and quick start up (less than 500ms) is achieved without any additional circuit

In order to reduce the switching losses and improve EMI performance, Quasi-Resonant switching mode is applied, which means to turn on the power MOSFET at voltage valley; The start up current of SY5018B is rather small (5 μ A typically) to reduce the standby power loss further. The maximum switching frequency is clamped to 100kHz to reduce switching losses and improve EMI performance; Specific design is adopted to ensure good performance when transition.

Adaptive PWM/PFM control is adopted for highest average efficiency.

SY5018B provides reliable protections such as Short Circuit Protection (SCP), Open LED Protection (OLP), Over Temperature Protection (OTP), transformer shorted protection and power diode shorted protection, etc.

SY5018B is available with SO8 package.

Applications Information

Start up

After AC supply or DC BUS is powered on, the capacitor C_{VIN} across VIN and GND pin is charged up by BUS voltage through a start up resistor R_{ST} . Once V_{VIN} rises up to $V_{VIN,ON}$, the internal blocks start to work and PWM output is enabled.

The output voltage is feedback by VSEN pin, which is taken as V_{FB} . If V_{FB} is lower than certain threshold $V_{FB,LOW}$, which means the output voltage is not built up, V_{COMP} is pulled up to high clamped; if V_{FB} is higher than

$V_{FB,LOW}$, V_{COMP} is under charge of the internal gain modulator.

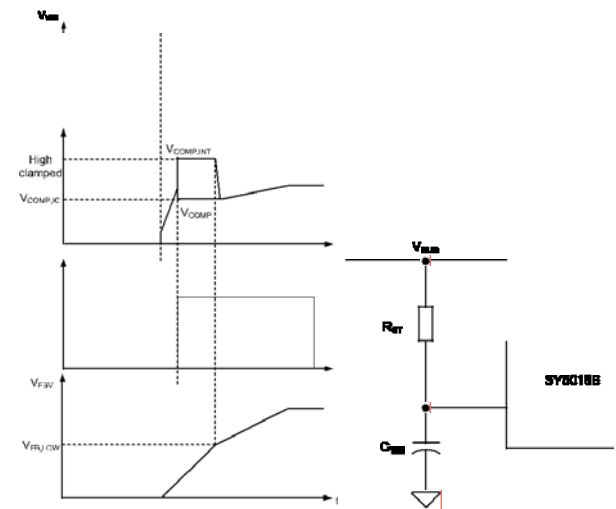

Fig3. Start up

This operation is aimed to build up enough output voltage for auxiliary winding bias supply as quickly as possible. It is enabled only one time just when V_{VIN} is over $V_{VIN,ON}$.

V_{COMP} is pre-charged by internal current source to $V_{COMP,IC}$ and hold at this level until fast start up process is finished.

The start up resistor R_{ST} and C_{VIN} are designed by rules below:

(a) Preset start-up resistor R_{ST} , make sure that the current through R_{ST} is larger than I_{ST} and smaller than I_{VIN_OVP}

$$\frac{V_{BUS}}{I_{VIN_OVP}} < R_{ST} < \frac{V_{BUS}}{I_{ST}}$$

Where V_{BUS} is the BUS line voltage.

(b) Select C_{VIN} to obtain an ideal start up time t_{ST} , and ensure the output voltage is built up at one time.

$$C_{VIN} = \frac{\left(\frac{V_{BUS}}{R_{ST}} - I_{ST}\right) \times t_{ST}}{V_{VIN_ON}}$$

(d) If the C_{VIN} is not big enough to build up the output voltage at one time. Increase C_{VIN} and decrease R_{ST} , go back to step (a) and redo such design flow until the ideal start up procedure is obtained.

Shut down

After AC supply or DC BUS is powered off, the energy stored in the BUS capacitor will be discharged. When the auxiliary winding of Flyback transformer can not supply enough energy to VIN pin, V_{VIN} will drop down. Once V_{VIN} is below V_{VIN,OFF}, the IC will stop working and V_{COMP} will be discharged to zero.

Quasi-Resonant Operation

QR mode operation provides low turn-on switching losses for Flyback converter.

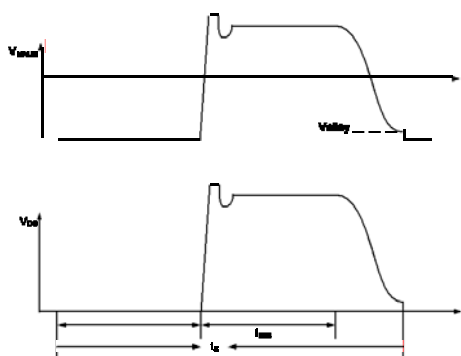

Fig.4 QR mode operation

The voltage across drain and source of the primary MOSFET is reflected by the auxiliary winding of the Flyback transformer. VSEN pin detects the voltage across the auxiliary winding by a resistor divider. When the voltage across drain and source of the primary MOSFET is at voltage valley, the MOSFET would be turned on.

Output Voltage Control

In order to achieve primary side constant voltage control, the output voltage is detected by the auxiliary winding voltage.

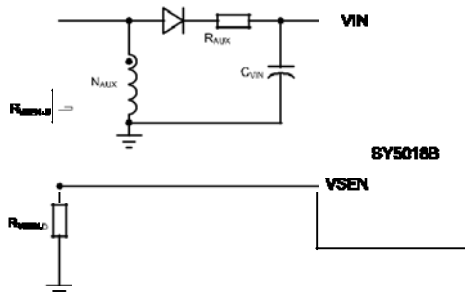

Fig.5 VSEN pin connection

As shown in Fig.6, during OFF time, the voltage across the auxiliary winding is

$$V_{AUX} = (V_{OUT} + V_{D,F}) \times \frac{N_{AUX}}{N_S}$$

N_{AUX} is the turns of auxiliary winding; N_S is the turns of secondary winding; V_{D,F} is the forward voltage of the power diode.

At the current zero-crossing point, V_{D,F} is nearly zero, so V_{OUT} is proportional with V_{AUX} exactly. The voltage of this point is sampled by the IC as the feedback of output voltage. The resistor divider is designed by

$$V_{OUT} = \frac{V_{SEN, REF}}{\frac{R_{VSEN,U}}{V_{SEN,U}} + \frac{R_{VSEN,D}}{V_{SEN,D}}} \times \frac{N_{AUX}}{N_S}$$

Where V_{SEN,REF} is the internal voltage reference.

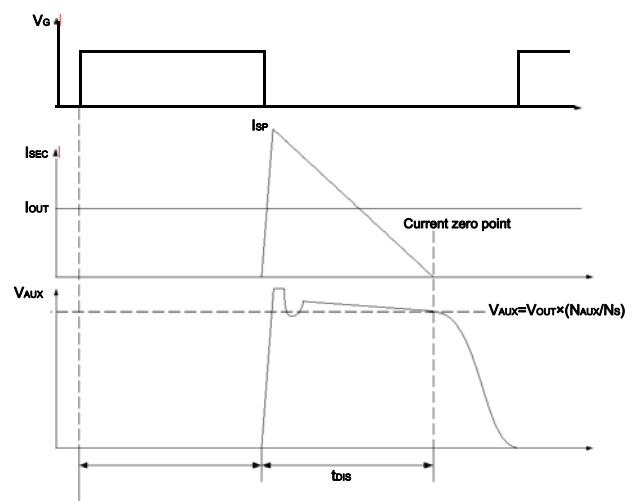

Fig.6 Auxiliary winding voltage waveforms

Output Current Limit

According to equation: $I_{OUT} = \frac{I_{PEAK} \times N \times T_{DIS}}{2 \times N_S \times T_S}$

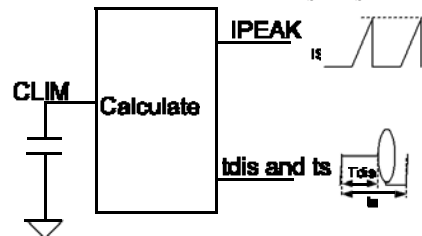

Fig.7 Current sense

Function of CLIM is limit maximum output current.

When setting V_{ISEN} ≈ 0.9V at minimum input voltage full load, output current will be limit at about 1.2 times the rated current.

Special Design For Transition

To have good transition performance, special design is integrate into SY5018B.

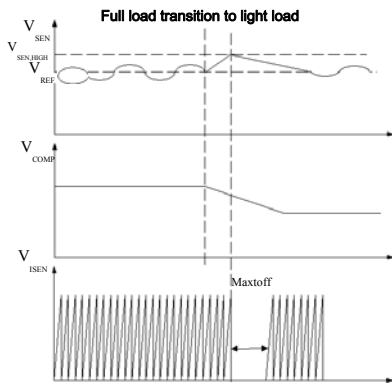

When VSEN touch $V_{FB,HIGH}$, IC work at Max toff mode to decrease output energy, and COMP is pulled down to decrease the energy output.

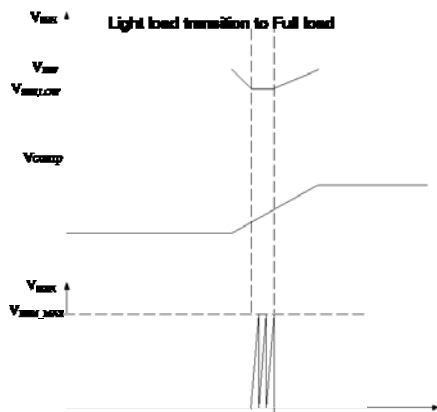

When VSEN touch $V_{FB,LOW}$, IC work at Max Ipeak to expedite output energy, and COMP is charged to increase the energy output.

Design of R_{ISEN}

The maximum power inductor current ($I_{P_PK_MAX}$) occur in minimum input voltage when full load. So R_{ISEN} could be selected by:

$$R_{ISEN} = \frac{90\% \times V_{ISEN,LIMIT}}{I_{P_PK_MAX}}$$

Where $V_{ISEN,LIMIT}$ is a protection for transformer (If V_{ISEN} touch this voltage, gate will turn off), and $I_{P_PK_MAX}$ is the maximum power inductor in steady.

Short Circuit Protection (SCP)

When the output is shorted to ground, the output voltage is clamped to zero. The voltage of the auxiliary winding is proportional to the output winding, so valley signal cannot be detected by VSEN. Without valley detection, MOSFET cannot be turned ON until maximum off time $t_{OFF,MAX}$ is matched. If MOSFET is turned ON by $t_{OFF,MAX}$ 64 times continuously, IC will be shut down and enter into hiccup mode.

Single fault design

If VSEN pin is shorted to GND pin or floating, valley detection is failed, which is similar to SLP, the system will operate in hiccup mode.

If the transformer is shorted, V_{ISEN} will exceeds $V_{ISEN,EX}$, which will trigger IC hiccup operation. The protection above is also suitable for secondary diode short.

Power Device Design

MOSFET and Diode

When the operation condition is with maximum input voltage and full load, the voltage stress of MOSFET and secondary power diode is maximized;

$$V_{MOS_DS_MAX} = \sqrt{2} V_{AC_MAX} + N_{PS} \times (V_{OUT} + V_{D_F}) + \Delta V_S$$

$$V_{D_R_MAX} = \frac{\sqrt{2} V_{AC_MAX}}{N_{PS}} + V_{OUT}$$

Where $V_{AC,MAX}$ is maximum input AC RMS voltage; N_{PS} is the turns ratio of the Flyback transformer; V_{OUT} is the rated output voltage; $V_{D,F}$ is the forward voltage of secondary power diode; ΔV_S is the overshoot voltage clamped by RCD snubber during OFF time.

When the operation condition is with minimum input voltage and full load, the current stress of MOSFET and power diode is maximized.

$$I_{MOS_PK_MAX} = I_{P_PK_MAX}$$

$$I_{MOS_RMS_MAX} = N_{PS} \times I_{P_RMS_MAX}$$

$$I_{D_PK_MAX} = I_{OUT}$$

$$I_{D_AVG} = I_{OUT}$$

Where $I_{P_PK_MAX}$ and $I_{P_RMS_MAX}$ are maximum primary peak current and RMS current, which will be introduced later.

Transformer (N_{PS} and L_M)

N_{PS} is limited by the electrical stress of the power MOSFET:

$$N_{PS} \leq \frac{V_{MOS(BR)DS} \times 90\% - \sqrt{Z_V} V_{AC_MAX} - \Delta V_S}{V_{OUT} + V_{D_F}}$$

Where $V_{MOS(BR)DS}$ is the breakdown voltage of the power MOSFET.

In Quasi-Resonant mode, each switching period cycle t_S consists of three parts: current rising time t_1 , current falling time t_2 and quasi-resonant time t_3 shown in Fig.8.

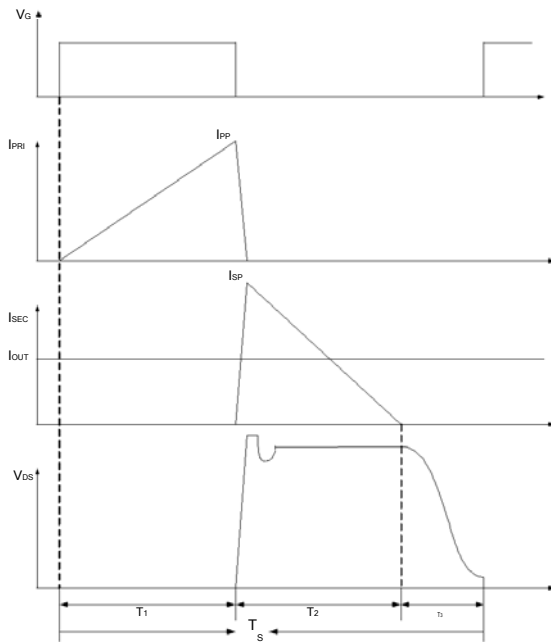

Fig.8 switching waveforms

The system operates in the constant on time mode to achieve high power factor. The ON time increases with the input AC RMS voltage decreasing and the load increasing. When the operation condition is with minimum input AC RMS voltage and full load, the ON time is maximized. On the other hand, when the input voltage is at the peak value, the OFF time is maximized. Thus, the minimum switching frequency f_{S-MIN} happens at the peak value of input voltage with minimum input AC RMS voltage and maximum load condition; meanwhile,

the maximum peak current through MOSFET and the transformer happens.

Once the minimum frequency f_{S-MIN} is set, the inductance of the transformer could be induced. The design flow is shown as below:

(a) Select N_{PS}

$$N_{PS} \leq \frac{V_{MOS(BR)DS} \times 90\% - \sqrt{Z_V} V_{AC_MAX} - \Delta V_S}{V_{OUT} + V_{D_F}}$$

(b) Preset minimum frequency f_{S-MIN} (Generally, f_{S-MIN} is not suggested higher than 70kHz when the input voltage is whole range)

(c) Compute relative t_S , t_1 (t_3 is omitted to simplify the design here)

$$t_S = \frac{1}{f_{S_MIN}}$$

$$t_1 = \frac{t_S \times N_{PS} \times (V_{OUT} + V_{D_F})}{\sqrt{2} V_{AC_MIN} + N_{PS} \times (V_{OUT} + V_{D_F})}$$

(d) Design inductance L_M

$$L_M = \frac{V_{AC_MIN}^2}{2P_{OUT} \times t_S \times \eta}$$

(e) Compute t_3

$$t_3 = \pi \times \sqrt{L_M \times C_{Drain}}$$

Where C_{Drain} is the parasitic capacitance at drain of MOSFET.

(f) Compute primary maximum peak current $I_{P-PK-MAX}$ and RMS current $I_{P-RMS-MAX}$ for the transformer fabrication.

$$I_{P_PK_MAX} = \frac{2P_{OUT} \times \left[\frac{L_M}{\sqrt{Z_V} V_{AC_MIN}^{IN}} + \frac{L_M}{N_{PS} \times (V_{OUT} + V_{D_F})} \right]}{L_M \times \eta}$$

$$I_{P_RMS_MAX} = \frac{\sqrt{4P_{OUT}^2 \times \left[\frac{L_M}{\sqrt{Z_V} V_{AC_MIN}^{IN}} + \frac{L_M}{N_{PS} \times (V_{OUT} + V_{D_F})} \right]^2 + 4L_M \times \eta \times P_{OUT} \times t_S}}{L_M \times \eta}$$

Where η is the efficiency; P_{OUT} is rated full load power

Adjust t_1 and t_S to t_1' and t_S' considering the effect of t_3

$$t_S' = \frac{\eta \times L_M \times I_{P_PK_MAX}^2}{4P_{OUT}}$$



SILERGY

AN_SY5018B

$$t'_1 = \frac{M}{L} \times \frac{I_{P_PK_MAX}}{\sqrt{2} V_{AC_MIN}}$$

$$I_{P_RMS_MAX} \approx \sqrt{\frac{t'_1}{6t'_S}} \times I_{P_PK_MAX}$$

(g) Compute secondary maximum peak current $I_{S_PK_MAX}$ and RMS current $I_{S_RMS_MAX}$ for the transformer fabrication.

$$I_{S_PK_MAX} = N_{PS} \times I_{P_PK_MAX}$$

$$t'_2 = t'_S - t'_1 - t_3$$

$$N_{AUX} = N_S \times \frac{V_{VIN}}{V_{OUT}}$$

Where V_{VIN} is the working voltage of VIN pin (10V~20V is recommended).

(f) Select an appropriate wire diameter

With $I_{P_RMS_MAX}$ and $I_{S_RMS_MAX}$, select appropriate wire to make sure the current density ranges from $4A/mm^2$ to $10A/mm^2$.

(g) If the winding area of the core and bobbin is not enough, reselect the core style, go to (a) and redesign the transformer until the ideal transformer is achieved.

(d) Compute secondary turn N_S

$$N_S = \frac{N_P}{N_{PS}}$$

(e) compute auxiliary turn N_{AUX}

(a) To achieve better EMI performance and reduce line frequency ripples, the output of the bridge rectifier should be connected to the BUS line capacitor first, then to the switching circuit.

(b) The circuit loop of all switching circuit should be kept small: primary power loop, secondary loop and auxiliary power loop.

(c) The connection of primary ground is recommended as:

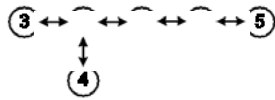

- Ground ①: ground of BUS line capacitor
- Ground ②: ground of bias supply capacitor
- Ground ③: ground node of auxiliary winding
- Ground ④: ground of signal trace
- Ground ⑤: primary ground node of Y capacitor
- Ground ⑥: ground node of current sample resistor.

(d) bias supply trace should be connected to the bias supply capacitor first instead of GND pin. The bias supply capacitor should be put beside the IC.

(e) Loop of 'Source pin – current sample resistor – GND pin' should be kept as small as possible.

(f) The resistor divider connected to VSEN pin is recommended to be put beside the IC.

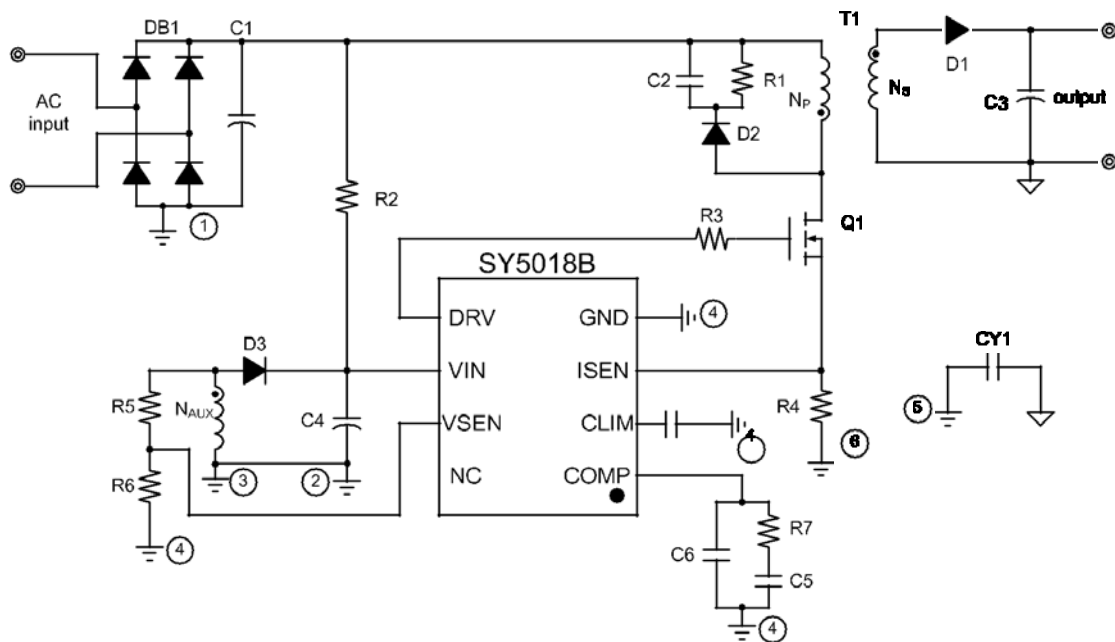
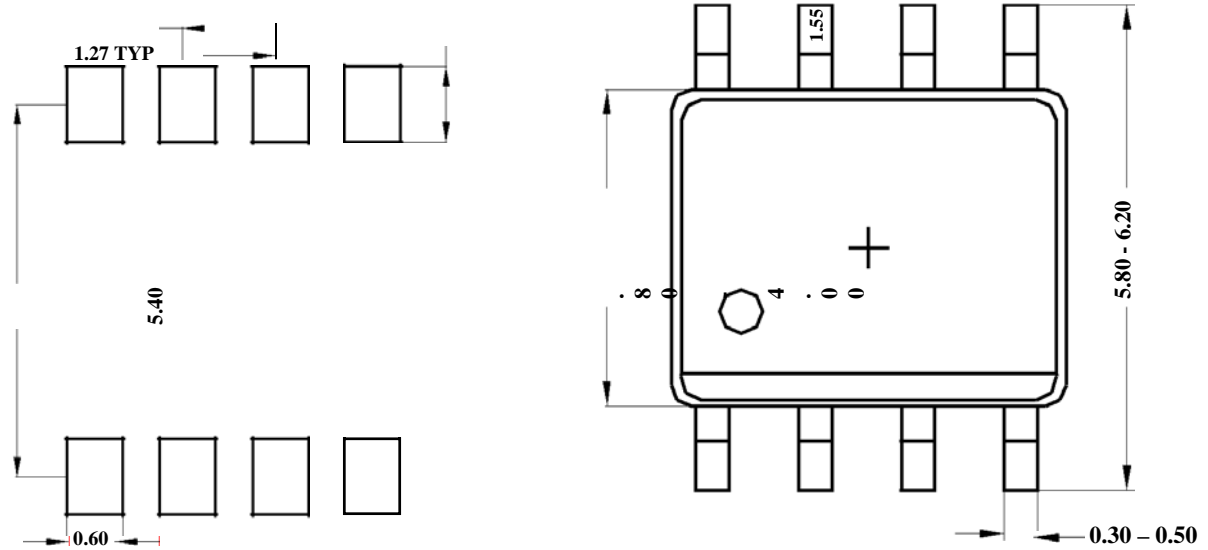
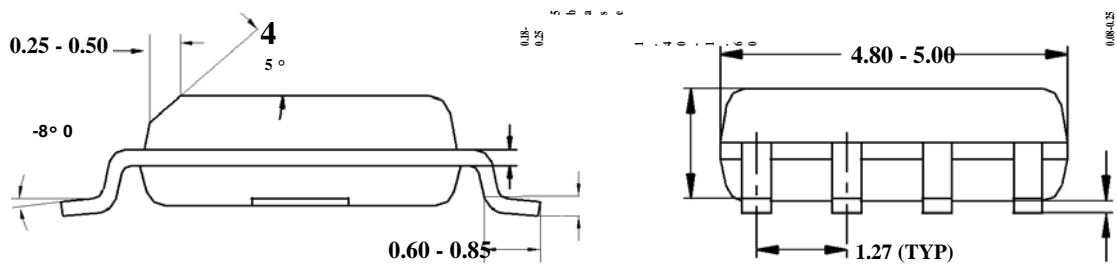

Fig.9. Recommended connection of GND

SO8 Package Outline & PCB Layout Design



Recommended Pad Layout



**Notes: All dimensions are in millimeters.
All dimensions don't include mold flash & metal burr.**

Taping & Reel Specification

1. Taping orientation for packages (SO8)

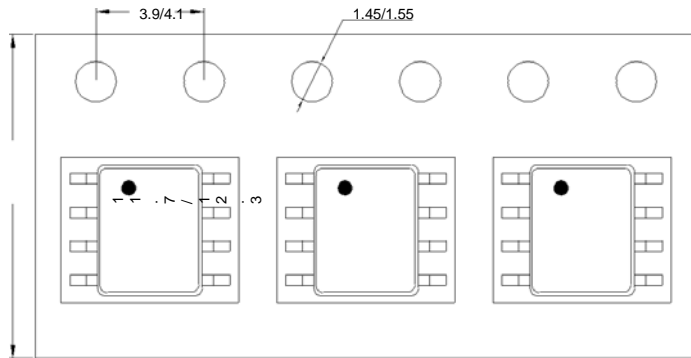

Feeding direction →

2. Carrier Tape & Reel specification for packages

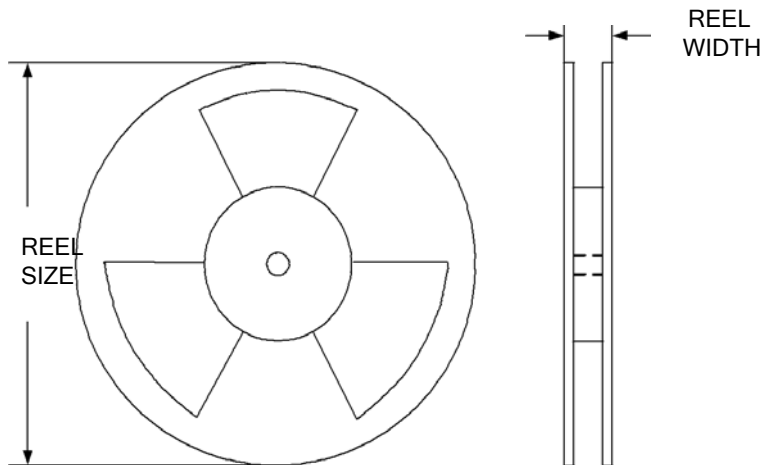

Package types	Tape width (mm)	Pocket pitch(mm)	Reel size (Inch)	Reel width(mm)	Trailer length(mm)	Leader length (mm)	Qty per reel
SOP8	12	8	13"	12.4	400	400	2500

X-ON Electronics

Largest Supplier of Electrical and Electronic Components

Click to view similar products for [LED Display Drivers](#) category:

Click to view products by [Silergy](#) manufacturer:

Other Similar products are found below :

[STP16CPP05XTTR](#) [SCT2027CSSG](#) [KP22306WGA](#) [KP1199AWPA](#) [KP1199BWPA](#) [WS9088AS7P](#) [GN1628T](#) [BCT3236EGH-TR](#)
[HT1628BRWZ](#) [KP1192SPA](#) [KP1182SPA](#) [KP1262FSPA](#) [KP1072LSPA](#) [KP1191SPA](#) [KP18001WPA](#) [KP1070LSPA](#) [KP1221SPA](#)
[KP107ALSPA](#) [GN1640T](#) [MBI5253GP-A](#) [MBI5124GM-B](#) [WS90561T S7P](#) [WS9821B S7P](#) [WS9032GS7P](#) [LYT3315D](#) [M08888G-11](#)
[M08890G-13](#) [SCT2001ASIG](#) [SCT2024CSOG](#) [SCT2024CSSG](#) [AL8400QSE-7](#) [PR4401](#) [PR4403](#) [PCA9685PW](#) [STP16CPC05XTTR](#)
[WS2821B](#) [PR4402](#) [M08898G-13](#) [RT8471GJ5](#) [RT9284A-20GJ6E](#) [TLC59482DBQR](#) [ISL97634IRT14Z-TK](#) [AW36413CSR](#) [LP5562TMX](#)
[WS2818B](#) [BCR401R](#) [BCR401U](#) [BCR402U](#) [SCT2004CSOG](#) [SCT2026CSOG](#)