



# Application Notes: AN\_SY5861B

## Adaptive LED Current Filter

### For LED Lighting

*Preliminary datasheet*

## General Description

The SY5861B is an adaptive linear current regulator to eliminate low frequency current ripple targeting at LED lighting applications.

It is applied as a current filter to the output of a LED driver, especially single stage LED driver. It adopts adaptive control scheme and no additional electrical design is needed.

Reliable open/short LED protection and over thermal protection are all provided.

## Ordering Information

SY5861 □(□□)□

- └─ Temperature Code
- └─ Package Code
- └─ Optional Spec Code

Ordering Number	Package type	Note
SY5861BFAC	SO8	----

## Features

- Current filter for single stage LED driver to eliminate current ripple
- Proprietary scheme for low power loss  $\leq 2.5\%$
- Adaptive for wide output speculation :  
Output voltage range from 20V to 100V  
Output current  $\leq 250\text{mA}$
- Open LED Protection and Short LED protection
- Reliable short LED and Open LED protection
- Compact package: SO8

## Applications

- LED lighting

## Typical Applications

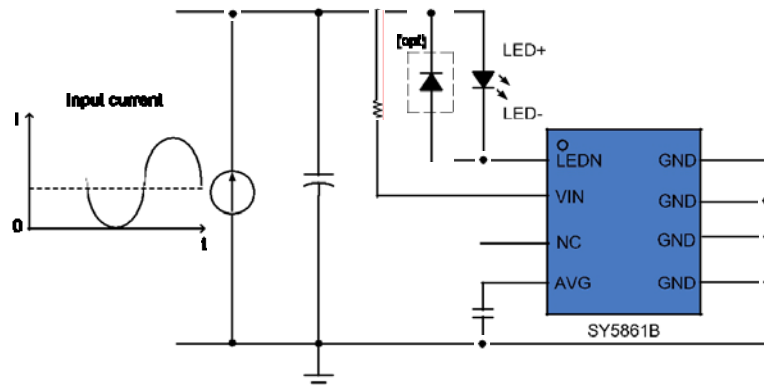
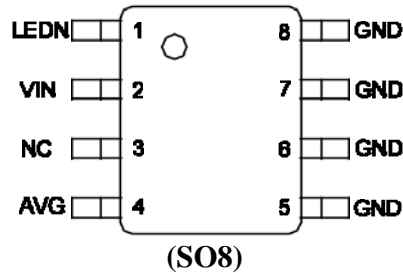

Figure 1. Schematic Diagram

## Pinout (top view)



Top Mark: AZBxyz (device code: AZB, x=year code, y=week code, z=lot number code)

Pin Name	Pin Number	Pin Description
LEDN	1	Cathode of LED string.
VIN	2	Power Supply. Cascade a resistor (10KΩ) to this pin and anode of the LED string.
NC	3	NC.
AVG	4	Average current filter pin. Bypass a capacitor (100nF) to this pin and GND.
GND	5/6/7/8	Ground pin

## Absolute Maximum Ratings (Note 1)

VIN	-0.3V~100V
LEDN	-0.3~100V
Power Dissipation, @ T <sub>A</sub> = 25°C SO8	0.6W
Package Thermal Resistance (Note 2)	
SO8, θ <sub>JA</sub>	88°C/W
SO8, θ <sub>JC</sub>	45°C/W
Junction Temperature Range	40°C to 150°C
Lead Temperature (Soldering, 10 sec.)	260°C
Storage Temperature Range	65°C to 150°C

## Recommended Operating Conditions

VIN, LEDN	20V~100V
-----------	----------



## Electrical Characteristics

( $V_{IN} = 12V$ ,  $T_A = 25^\circ C$  unless otherwise specified)

Parameter	Symbol	Test Conditions	Min	Typ	Max	Unit
Power Supply Section						
VIN turn-on threshold	$V_{VIN,ON}$		9.5	10	10.5	V
VIN turn-off threshold	$V_{VIN,OFF}$		7.2	7.8	8.2	V
VIN operating current	$I_{VIN}$		64	77	90	$\mu A$
Thermal Section						
Thermal Shutdown Temperature	$T_{SD1}$	$V_{LEDN} < 15V$		150		C
Thermal Shutdown Temperature	$T_{SD2}$	$V_{LEDN} > 15V$		100		C
Thermal Hysteresis Temperature	$T_{HYS}$			20		C

**Note 1:** Stresses beyond the “Absolute Maximum Ratings” may cause permanent damage to the device. These are stress ratings only. Functional operation of the device at these or any other conditions beyond those indicated in the operational sections of the specification is not implied. Exposure to absolute maximum rating conditions for extended periods may affect device reliability.

**Note 2:**  $f_{JA}$  is measured in the natural convection at  $T_A = 25^\circ C$  on a low effective single layer thermal conductivity test board of JEDEC 51-3 thermal measurement standard. Test condition: Device mounted on 2” x 2” FR-4 substrate PCB, 2oz copper, with minimum recommended pad on top layer and thermal vias to bottom layer ground plane.

## Operation

The SY5861B is an adaptive linear current regulator to eliminate low frequency current ripple targeting at LED lighting applications.

It is applied as a current filter to the output of a LED driver, especially single stage LED driver. It adopts adaptive control scheme and no additional electrical design is needed.

It is adaptive for wide output speculation, the output voltage is ranging from 20V to 100V; the maximum output current is 250mA. It adopts proprietary scheme for low power loss and the efficiency loss is no more than 2.5%. It also can be operated in parallel to support higher LED current.

SY5861B provides reliable protections such as Short LED Protection (SLP), Open LED Protection (OLP), and Over Temperature Protection (OTP).

SY5861B is available with SO8.

## Applications Information

### Start up

When  $V_{VIN}$  rises up over  $V_{VIN-ON}$ , SY5861B starts to work. At first, it has 250ms blanking time without current filter function to build up stable reference internally. Then the LED current ripple is decreased by SY5861B gradually.

### Shut down

When  $V_{VIN}$  drops below  $V_{VIN-OFF}$ , LEDN Pin is high impedance to GND Pin.

### Parallel operation application

SY5861B can be operated in parallel to support higher LED current. The circuit is shown in below.

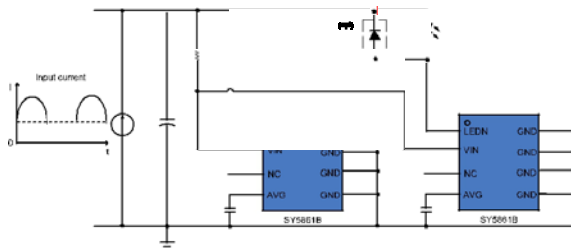
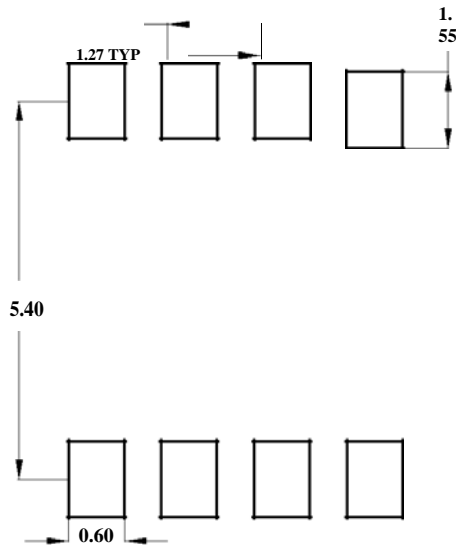
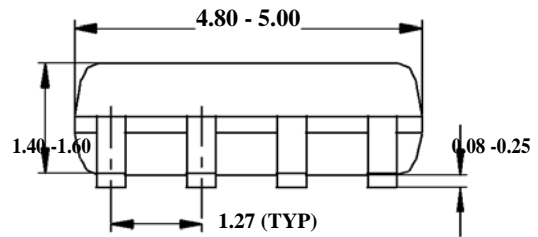
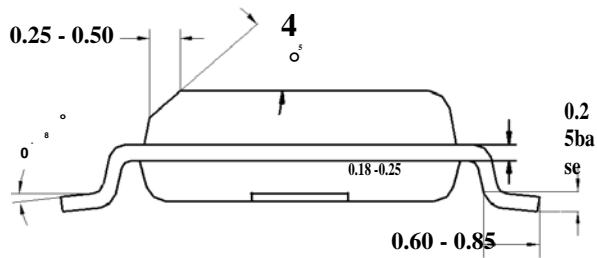
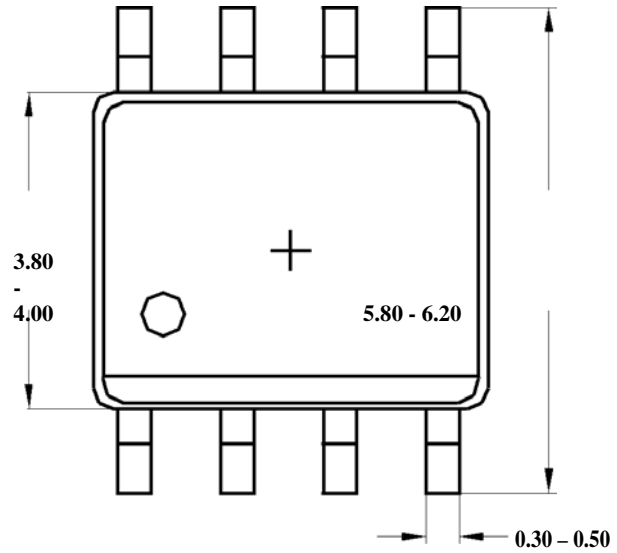

Fig. Parallel circuit

## SO8 Package Outline & PCB Layout Design



Recommended Pad Layout



Notes: All dimensions are in millimeters.

**All dimensions don't include mold flash & metal burr.**

## X-ON Electronics

Largest Supplier of Electrical and Electronic Components

*Click to view similar products for [LED Display Drivers](#) category:*

*Click to view products by [Silergy](#) manufacturer:*

Other Similar products are found below :

[STP16CPP05XTTR](#) [SCT2027CSSG](#) [KP22306WGA](#) [KP1199AWPA](#) [KP1199BWPA](#) [GN1628T](#) [BCT3236EGH-TR](#) [HT1628BRWZ](#)  
[KP1192SPA](#) [KP1182SPA](#) [KP1262FSPA](#) [KP1072LSPA](#) [KP1191SPA](#) [KP18001WPA](#) [KP1070LSPA](#) [KP1221SPA](#) [KP107ALSPA](#) [GN1640T](#)  
[MBI5253GP-A](#) [WS90561T](#) [S7P](#) [WS9821B](#) [S7P](#) [WS9032GS7P](#) [LYT3315D](#) [M08888G-11](#) [M08890G-13](#) [SCT2001ASIG](#) [SCT2024CSOG](#)  
[SCT2024CSSG](#) [AL8400QSE-7](#) [PR4401](#) [PR4403](#) [PCA9685PW](#) [STP16CPC05XTTR](#) [WS2821B](#) [PR4402](#) [M08898G-13](#) [RT8471GJ5](#)  
[TLC59482DBQR](#) [ISL97634IRT14Z-TK](#) [AW36413CSR](#) [LP5562TMX](#) [WS2818B](#) [BCR401R](#) [BCR401U](#) [BCR402U](#) [SCT2004CSOG](#)  
[SCT2026CSOG](#) [SCT2026CSSG](#) [SCT2932F](#) [SCT2932J](#)