



Application Notes: AN_SY5863

Adaptive LED Current Filter For LED Lighting

General Description

The SY5863 is an adaptive linear current regulator to eliminate low frequency current ripple targeting at LED lighting applications.

It is applied as a current filter to the output of a LED driver, especially single stage LED driver. It adopts adaptive control scheme and no additional electrical design is needed.

Reliable open/short LED protection and over thermal protection are all provided.

Ordering Information

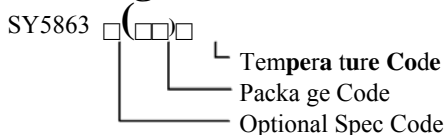

Ordering Number	Package type	Note
SY5863JAC	TO252-3	----

Features

- Current filter for single stage LED driver to eliminate current ripple
- Proprietary scheme for low power loss $\leq 2.5\%$
- Adaptive for wide output speculation :
Output voltage range from 20V to 60V
Output current range from 0.25A to 1.2A
- Open LED Protection and Short LED protection
- Reliable short LED and Open LED protection
- Compact package: TO252 -3

Applications

- LED lighting

Typical Applications

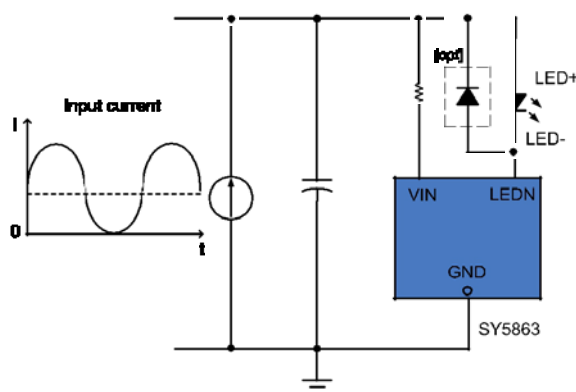
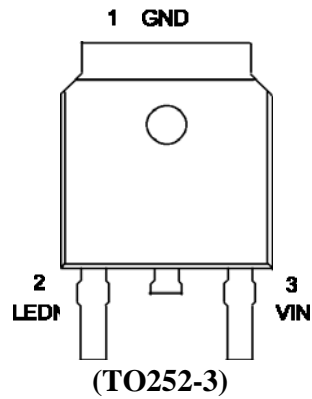

Fig. 1. Schematic Diagram

Pinout (top view)



Top Mark:AYDxyz (device code: AYD, *x=year code*, *y=week code*, *z=lot number code*)

Pin Name	Pin Description
LEDN	Cathode of LED string.
VIN	Power Supply
GND	Ground pin

Block Diagram

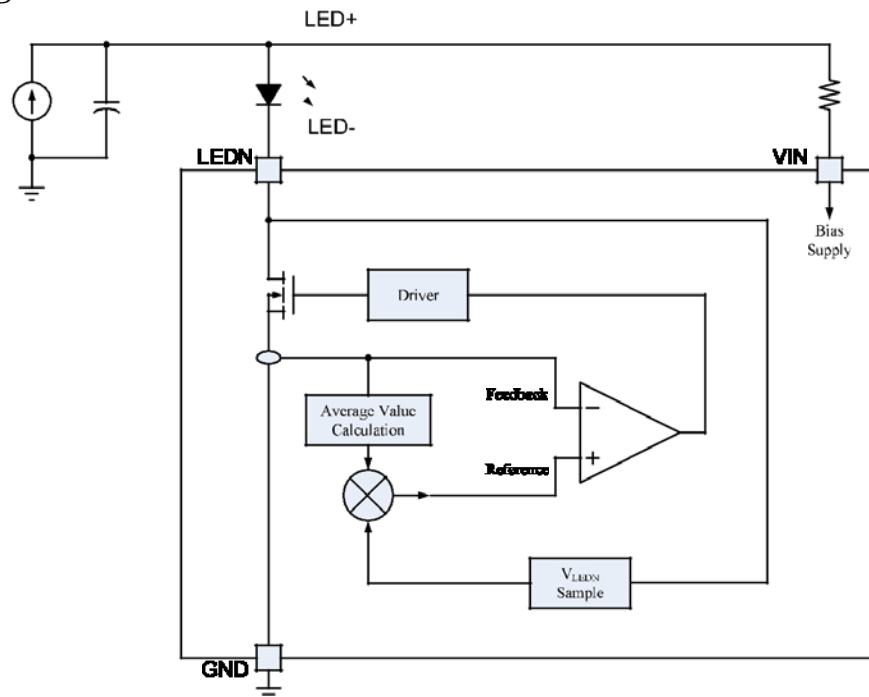

Fig. 2. Block diagram



Absolute Maximum Ratings (Note 1)

VIN	-0.3~60V
LEDN	-0.3~60V
Power Dissipation, @ TA = 25°C TO252-3 (Note 2)	2.5W
Package Thermal Resistance (Note 2)	
TO252-3, θ_{JA}	50°C/W
TO252-3, θ_{JC}	4.5°C/W
Junction Temperature Range	-40°C to 150°C
Lead Temperature (Soldering, 10 sec.)	260°C
Storage Temperature Range	-65°C to 150°C

Recommended Operating Conditions

VIN, LEDN	20V~60V
-----------------	---------



Electrical Characteristics

($V_{IN} = 12V$, $T_A = 25^{\circ}C$ unless otherwise specified)

Parameter	Symbol	Test Conditions	Min	Typ	Max	Unit
Power Supply Section						
VIN turn-on threshold	V_{VIN_ON}		2.9	3.4	4.1	V
VIN turn-off threshold	V_{VIN_OFF}		2.7	3.2	3.9	V
VIN operating current	I_{VIN}		70	91	120	μA
LEDN section						
High Voltage Protection	V_{LEDN_HV}		4.3	4.85	5.3	V
Over Voltage Protection	V_{LEDN_OV}		12.3	14	15.7	V
Thermal Section						
Thermal Shutdown Temperature	I_{SD1}	V_{LEDN} V_{LEDN_OV}		150		$^{\circ}C$
Thermal Shutdown Temperature	I_{SD2}	V_{LEDN} V_{LEDN_OV}		100		$^{\circ}C$
Thermal Hysteresis	I_{HYS}			20		$^{\circ}C$

Note 1: Stresses beyond the “Absolute Maximum Ratings” may cause permanent damage to the device. These are stress ratings only. Functional operation of the device at these or any other conditions beyond those indicated in the operational sections of the specification is not implied. Exposure to absolute maximum rating conditions for extended periods may affect device reliability.

Note 2: f_{JA} is measured in the natural convection at $T_A = 25^{\circ}C$ on a low effective single layer thermal conductivity test board of JEDEC 51-3 thermal measurement standard. Test condition: Device mounted on 2” x 2” FR-4 substrate PCB, 2oz copper, with minimum recommended pad on top layer and thermal vias to bottom layer ground plane.



General Applications

The SY5863 is an adaptive linear current regulator to eliminate low frequency current ripple targeting at LED lighting applications.

It is applied as a current filter to the output of a LED driver, especially single stage LED driver. It adopts adaptive control scheme and no additional electrical design is needed.

It is adaptive for wide output speculation, the output voltage is ranging from 20V to 60V; the maximum output current is 1.2A. It adopts proprietary scheme for low power loss and the efficiency loss is no more than 2.5%. It also can be operated in parallel to support higher LED current.

SY5863 provides reliable protections such as Short LED Protection (SLP), Open LED Protection (OLP), and Over Temperature Protection (OTP).

SY5863 is available with TO252-3

Start up

When V_{VIN} rises up over V_{VIN_ON} , internal blocks start to work. At first, it has certain blanking time without current filter function to build up stable average current reference internally. Then the LED current ripple is suppressed gradually.

Shut down

When V_{VIN} drops down below V_{VIN_OFF} , LEDN Pin is changed to high impedance to GND Pin.

Steady state

LED current is sampled and processed inside the IC. The average value of LED current is taken as the reference to regulate the instantaneous current. At the same time, V_{LEDN} is sensed and kept low to avoid high power loss on the IC.

If the input/output has certain dynamic turbulence, V_{LEDN} might be higher than V_{LEDN_HV} , then LED current ripple suppression will be loosened to make V_{LEDN} drop down quickly until V_{LEDN} is lower than V_{LEDN_HV} . Hence, the normal value of V_{LEDN} must be lower than V_{LEDN_HV} .

Open LED & Recover

When LED is open, LED current and V_{LEDN} both drop to zero naturally, the IC will quit the current filter function.

When LED is recovered, LED current is sensed and IC acts just like start up again.

Short LED & Recover

When LED is short, V_{LEDN} is pulled up high. If V_{LEDN} is higher than V_{LEDN_OV} , LED current will be limited at certain value and thermal shut down threshold is changed down to T_{SD2} .

When LED is recovered, V_{LEDN} is pulled down. If V_{LEDN} is lower than V_{LEDN_OV} , LED current limit is removed and thermal shut down threshold is changed back to T_{SD1} .

Parallel operation application

SY5863 can be operated in parallel to support higher LED current. The circuit is shown in below.

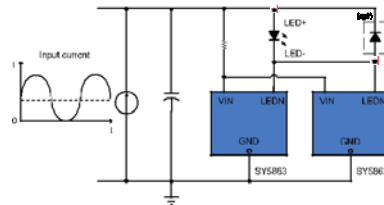
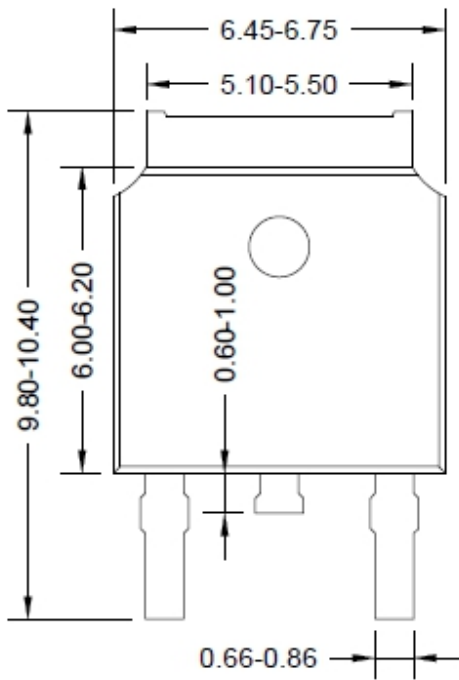
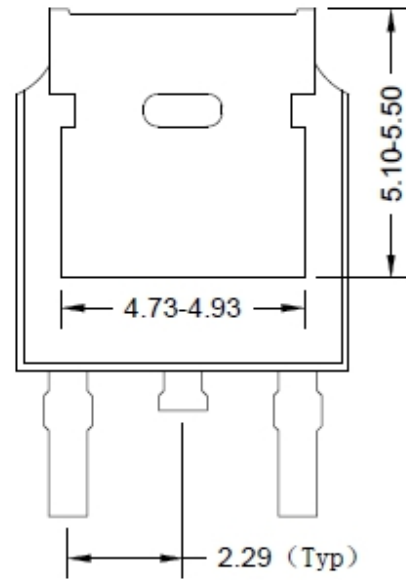
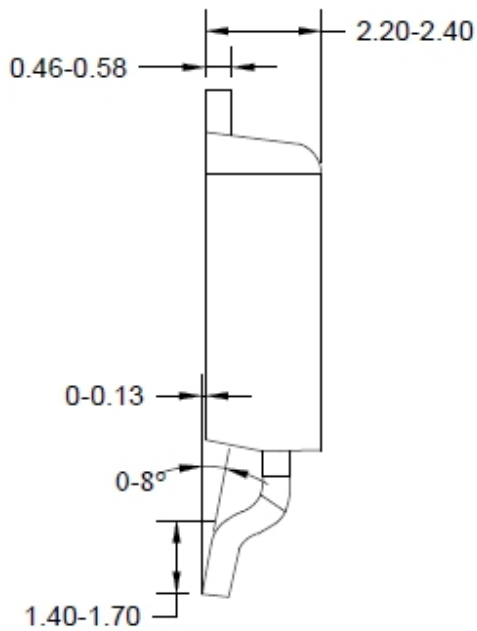

Fig.3 Parallel circuit

TO252-3 Package Outline & PCB layout

Top view

Bottom view

Side view

Notes: All dimension in mm and exclude mold flash & metal burr

X-ON Electronics

Largest Supplier of Electrical and Electronic Components

Click to view similar products for [LED Display Drivers](#) category:

Click to view products by [Silergy](#) manufacturer:

Other Similar products are found below :

[STP16CPP05XTTR](#) [SCT2027CSSG](#) [KP22306WGA](#) [WS9088AS7P](#) [BCT3236EGH-TR](#) [KP1192SPA](#) [KP1182SPA](#) [KP1262FSPA](#)
[KP1072LSPA](#) [KP1191SPA](#) [KP18001WPA](#) [KP1221SPA](#) [MBI5253GP-A](#) [MBI5124GM-B](#) [WS90561T S7P](#) [WS9821B S7P](#) [WS9032GS7P](#)
[TM1628A](#) [AW9963CSR](#) [WS2811M](#) [JW1965BSOPA#TRPBF](#) [TM3100](#) [MT7712SH](#) [STI9287CA](#) [JW1967EHSOPA#TRPBF](#) [FM8502A](#)
[TM1618\(TA1323C\)](#) [TM1810-2](#) [LD6802JGL](#) [AW2026DNR](#) [AW3644CSR](#) [MT7713SH](#) [SDH7711RHTR](#) [HT7219ARWZ](#) [LYT3315D](#)
[M08888G-11](#) [M08890G-13](#) [BCR420U](#) [SCT2001ASIG](#) [SCT2024CSSG](#) [SCT2167CSSG](#) [AL8400QSE-7](#) [PR4401](#) [PR4403](#) [MAX6965ATE+](#)
[PCA9685PW](#) [STP24DP05BTR](#) [STP16CPC05XTTR](#) [WS2821B](#) [PR4402](#)