

Figure.1b Dimming curve of analog dimming

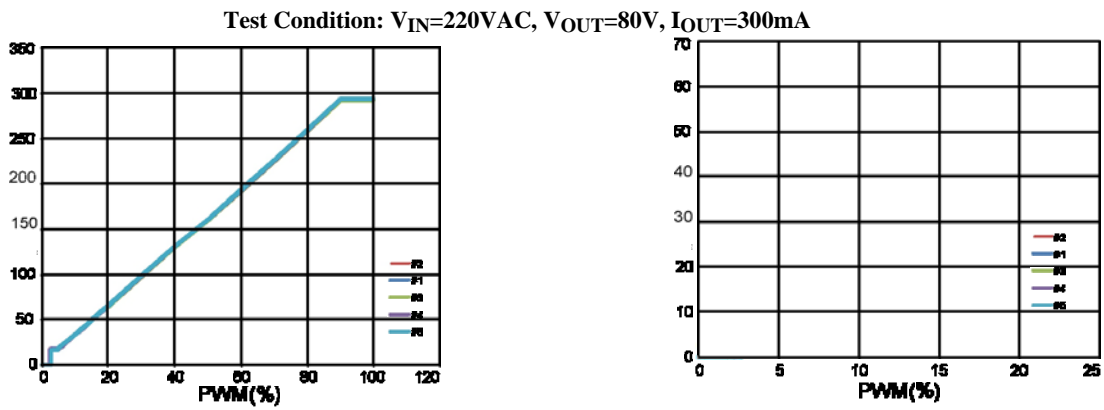
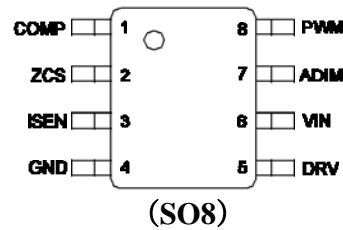
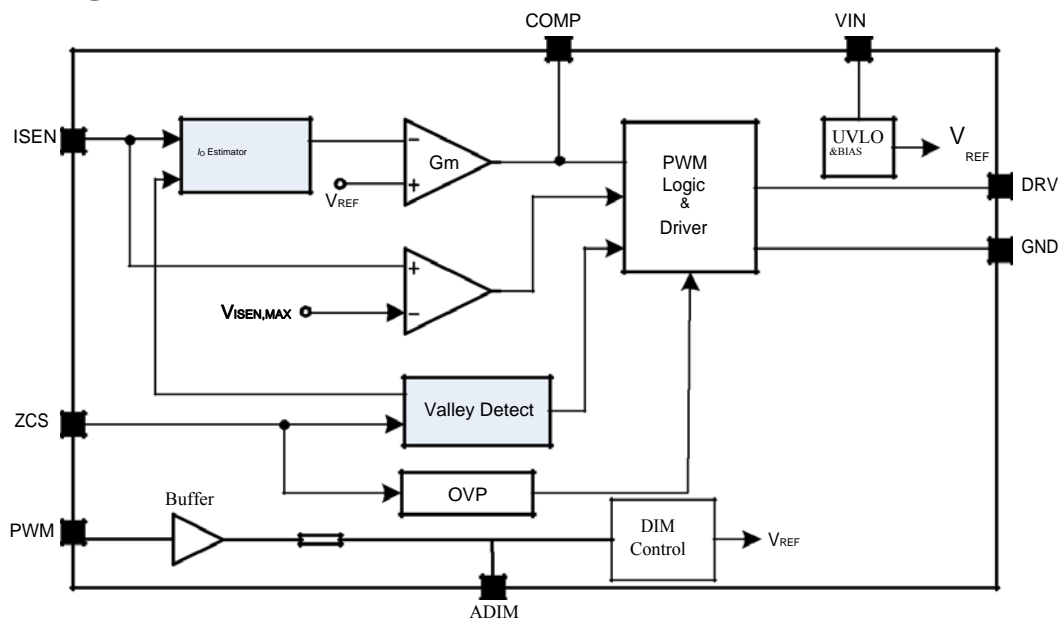

Figure.1c Actual curve of analog dimming VS. PWM input

Pinout (top view)

Top Mark: BEHxyz (device code: BEH, x=year code, y=week code, z= lot number code)

Pin Name	Pin number	Pin Description
COMP	1	Loop compensation pin. Connect a RC network across this pin and ground to stabilize the control loop.
ZCS	2	Inductor current zero-crossing detection pin. This pin receives the auxiliary winding voltage by a resistor divider and detects the inductor current zero crossing point. This pin also provides over voltage protection and line regulation modification function simultaneously. If the voltage on this pin is above $V_{ZCS,OV}$, the IC would enter over voltage protection mode. Good line regulation can be achieved by adjusting the upper resistor of the divider.
ISEN	3	Current sense pin. Connect this pin to the source of the primary switch. Connect the sense resistor across the source of the primary switch and the GND pin. (current sense resistor R_s : $R_s = \frac{V_{REF}}{Z \times I_{OUT}}$)
GND	4	Ground pin
DRV	5	Gate driver pin. Connect this pin to the gate of primary MOSFET.
VIN	6	Power supply pin. This pin also provides output over voltage protection along with ZCS pin.
ADIM	7	Bypass this pin to GND with enough capacitance to hold on internal voltage reference.
PWM	8	PWM dimming input pin, this pin detects the PWM dimming signal

Block Diagram

Figure.3 Block Diagram
Absolute Maximum Ratings (Note 1)

VIN, DRV	-----	-0.3V~25V
Supply current I _{VIN}	-----	7mA
ZCS, PWM	-----	-0.3V~23V
ADIM	-----	-0.3V~15V
ISEN, COMP	-----	-0.3~3.6V
Power Dissipation, @ T _A = 25°C SO8	-----	1.1W
Package Thermal Resistance (Note 2)		
SO8, θ _{JA}	-----	88°C/W
SO8, θ _{JC}	-----	45°C/W
Temperature Range	-----	-40°C to 150°C
Lead Temperature (Soldering, 10 sec.)	-----	260°C
Storage Temperature Range	-----	-65°C to 150°C

Recommended Operating Conditions (Note 3)

VIN, DRV	-----	8V~20V
----------	-------	--------



Electrical Characteristics

($V_{IN} = 12V$ (Note 3), $T_A = 25^\circ C$ unless otherwise specified)

Parameter	Symbol	Test Conditions	Min	Typ	Max	Unit
Power Supply Section						
VIN turn-on threshold	V_{VIN_ON}		19	20	22	V
VIN turn-off threshold	V_{VIN_OFF}		7.5	8.0	8.5	V
VIN OVP voltage	V_{VIN_OVP}			$V_{IN_ON}+3.0$		V
Start up Current	ST	V_{VIN} V_{VIN_OFF}		34		μA
Shunt current in OVP mode	V_{VIN_OVP}	V_{VIN} V_{VIN_OVP}		7		mA
Error Amplifier Section						
Internal reference voltage	V_{REF}			300		mV
Current Sense Section						
Current limit reference voltage	V_{ISEN_MAX}			750		mV
ZCS pin Section						
ZCS pin OVP voltage threshold	V_{ZCS_OVP}			1.5		V
Gate Driver Section						
Gate driver voltage	V_{Gate}			12		V
Maximum source current	SOURCE			200		mA
Minimum sink current	SINK			650		mA
Max ON Time	ON_MAX	$V_{COMP}=2.6V$		24		μs
Min ON Time	ON_MIN			300		ns
Max OFF Time	OFF_MAX			120		μs
Min OFF Time	OFF_MIN			0.5		μs
Maximum switching frequency	MAX			120		kHz
ADIM function Section						
ADIM Enable ON	V_{ADIM_ON}			75		mV
ADIM Enable OFF	V_{ADIM_OFF}			37		mV
Thermal Section						
Thermal Fold back Temperature	T_{FB}			145		$^\circ C$
Thermal shut down Temperature	T_{SD}			160		$^\circ C$
PWM function Section						
PWM ON voltage	V_{PWM_ON}				1.2	V
PWM OFF voltage	V_{PWM_OFF}		0.5			V

Note 1: Stresses beyond the “Absolute Maximum Ratings” may cause permanent damage to the device. These are stress ratings only. Functional operation of the device at these or any other conditions beyond those indicated in the operational sections of the specification is not implied. Exposure to absolute maximum rating conditions for extended periods may affect device reliability.

Note 2: f_{JA} is measured in the natural convection at $T_A = 25^\circ C$ on a low effective single layer thermal conductivity test board of JEDEC 51-3 thermal measurement standard. Test condition: Device mounted on 2” x 2” FR-4 substrate PCB, 2oz copper, with minimum recommended pad on top layer and thermal vias to bottom layer ground plane.

Note 3: Increase VIN pin voltage gradually higher than V_{VIN_ON} voltage then turn down to 12V.

Operation

The SY5881 is a single stage Buck and PFC controller targeting at LED lighting applications with multiple dimming function.

The Device provides primary side control to eliminate the opto-couplers or the secondary feedback circuits, which would cut down the cost of the system.

High power factor is achieved by constant on operation mode, with which the control scheme and the circuit structure are both simple.

SY5881 is compatible with Analog dimming and PWM dimming for different application.

In order to reduce the switching losses and improve EMI performance, Quasi-Resonant switching mode is applied, which means to turn on the power MOSFET at voltage valley;

the start up current of SY5881 is rather small (34μA typically)

to reduce the standby power loss further; the maximum switching frequency is clamped to 120kHz to reduce switching losses and improve EMI performance when the converter is operated at light load condition.

SY5881 provides reliable protections such as Short Circuit Protection (SCP), Open LED Protection (OLP), Over Temperature Protection (OTP), etc.

SY5881 is available with SO8 package.

Applications Information

Start up

After AC supply or DC BUS is powered on, the capacitor C_{VIN} across VIN and GND pin is charged up by BUS voltage through a start up resistor R_{ST} . Once V_{VIN} rises up to V_{VIN_ON} , the internal blocks start to work. V_{VIN} will be pulled down by internal consumption of IC until the auxiliary winding of Buck transformer could supply enough energy to maintain V_{VIN} above V_{VIN_OFF} .

The whole start up procedure is divided into two sections shown in Fig.4. t_{STC} is the C_{VIN} charged up section, and t_{STO} is the output voltage built-up section. The start up time t_{ST} composes of t_{STC} and t_{STO} , and usually t_{STO} is much smaller than t_{STC} .

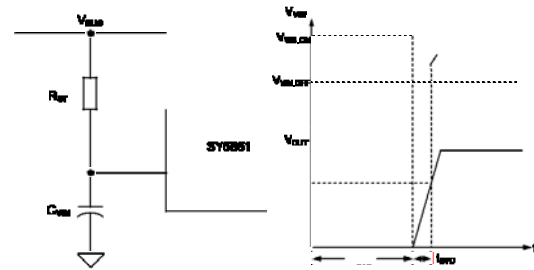

Fig.4 Start up

The start up resistor R_{ST} and C_{VIN} are designed by rules below:

(a) Preset start-up resistor R_{ST} , make sure that the current through R_{ST} is larger than I_{ST} and smaller than I_{VIN_OVP}

$$\frac{V_{BUS}}{I_{VIN_OVP}} < R_{ST} < \frac{V_{BUS}}{I_{ST}} \quad (1)$$

Where V_{BUS} is the BUS line voltage.

(b) Select C_{VIN} to obtain an ideal start up time t_{ST} , and ensure the output voltage is built up at one time.

$$C_{VIN} = \frac{\left(\frac{V_{BUS}}{R_{ST}} - I_{ST}\right) \times t_{ST}}{V_{VIN_ON}} \quad (2)$$

(d) If the C_{VIN} is not big enough to build up the output voltage at one time. Increase C_{VIN} and decrease R_{ST} , go back to step (a) and re-do such design flow until the ideal start up procedure is obtained.

Internal pre-charge design for quick start up

After V_{VIN} exceeds V_{VIN_ON} , V_{ADIM} and V_{COMP} is pre-charged by internal current sources in turn. V_{ADIM} is pre-charged first, and when V_{ADIM} is over the initial voltage V_{ADIM_IC} , V_{COMP} begins to be pre-charged. The PWM block won't start to output PWM signals until V_{COMP} is over the initial voltage V_{COMP_IC} . V_{COMP_IC} can be programmed by R_{COMP} . Such design is meant to reduce the start up time shown in Fig.5.

The voltage pre-charged V_{COMP_IC} in start-up procedure can be programmed by R_{COMP}

$$V_{COMP_IC} = 900\text{mV} - 300\mu\text{A} \times R_{COMP} \quad (3)$$

The voltage pre-charged V_{ADIM_IC} in start-up procedure is fixed internally.

$$V_{ADIM_IC} = 37mV$$

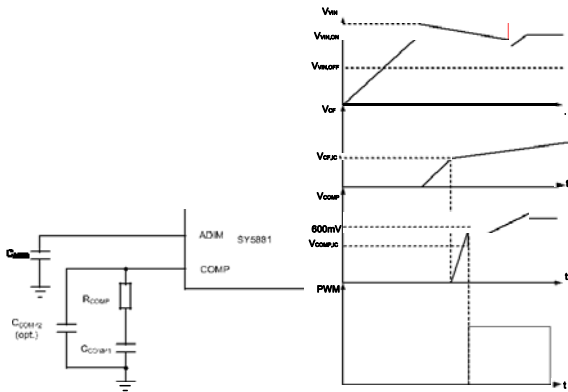

Fig.5 Pre-charge scheme in start up

Where V_{COMP_IC} is the pre-charged voltage of COMP pin.

Generally, a big capacitance of C_{COMP} is necessary to achieve high power factor and stabilize the system loop ($1\mu F \sim 2\mu F$ recommended).

The voltage pre-charged in start-up procedure can be programmed by R_{COMP} ; On the other hand, larger R_{COMP} can provide larger phase margin for the control loop; A small ceramic capacitor is added to suppress high frequency interruption ($10pF \sim 100pF$ is recommended if necessary)

Shut down

After AC supply or DC BUS is powered off, the energy stored in the BUS capacitor will be discharged. When the auxiliary winding of Buck transformer can not supply enough energy to VIN pin, V_{VIN} will drop down. Once V_{VIN} is below V_{VIN_OFF} , the IC will stop working and V_{COMP} will be discharged to zero.

Primary-side constant-current control

Primary side control is applied to eliminate secondary feedback circuit or opto-coupler, which reduces the circuit cost. The switching waveforms are shown in Fig.6.

The output current I_{OUT} can be represented by,

$$I_{OUT} = \frac{I_{PK} \times t_{EFF}}{2 \times t_S} \quad (4)$$

Where I_{PK} is the peak current of the inductor; t_{EFF} is the effective time of inductor current rising and falling; t_S is the switching period.

I_{PK} and t_{EFF} can be detected by Source and ZCS pin, which is shown in Fig.7. These signals are processed and applied to the negative input of the gain modulator. In static state, the positive and negative inputs are equal.

$$V_{REF} = I_{PK} \times R_S \times \frac{t_{EFF}}{t_S} \quad (5)$$

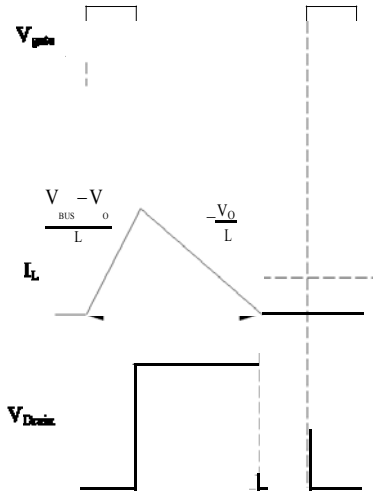

Fig.6 Switching waveforms

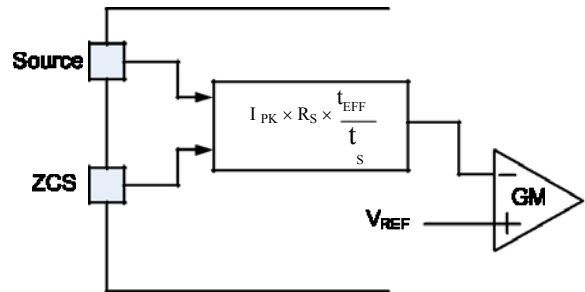

Fig.7 Output current detection diagram

Finally, the output current I_{OUT} can be represented by

$$I_{OUT} = \frac{V_{REF}}{R_S \times 2} \quad (6)$$

Where V_{REF} is the internal reference voltage; R_S is the current sense resistor.

V_{REF} is internal constant parameters I_{OUT} can be programmed by R_S .

$$R_S = \frac{V_{REF}}{I_{OUT} \times 2} \quad (7)$$

Quasi-Resonant Operation

QR mode operation provides low turn-on switching losses for the converter.

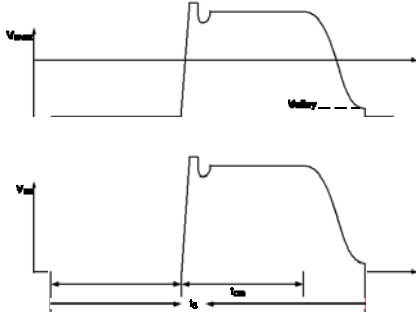

Fig.8 QR mode operation

The voltage across drain and source of the primary MOSFET is reflected by the auxiliary winding of the Buck transformer. ZCS pin detects the voltage across the auxiliary winding by a resistor divider. When the voltage across drain and source of the primary MOSFET is at voltage valley, the MOSFET would be turned on.

CV Mode

When PWM < 2.5%, IC and MCU still need bias power, so,

- (1) If Dimming signal is greater than 5.0%, IC always works at CC mode.
- (2) If Dimming signal is lower than 2.5%, CV mode is triggered. IC works in CV mode to maintain VFB nearby V_{ZCS_CV} . $N_p:N_s$ and R_{ZCS} could be adjusted to prevent LED flicker and bias supply enough.

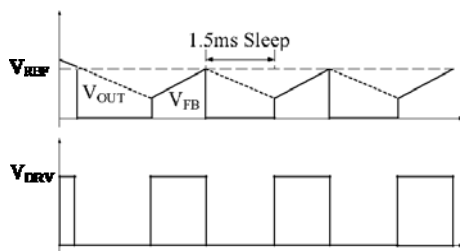

Figure.9 The working process of CV mode

In CV mode,

If V_{FB} is smaller than V_{ZCS_CV} , MOSFET turned off when ISEN voltage reach $V_{CV_ISEN_MAX}$ in every switching cycle, and turned on by QR.

If V_{FB} is greater than V_{ZCS_CV} , IC will sleep for 1.5ms, until V_{FB} is smaller than V_{ZCS_CV} .

The output of CV is decided by OVP.

$$V_{OUT_CV} \equiv \frac{V_{OUT_OVP}}{3}$$

Over Voltage Protection (OVP) & Open LED Protection (OLP)

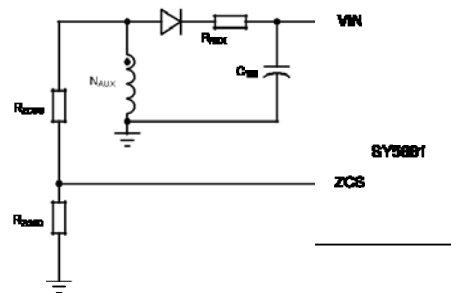

Fig.10 OVP&OLP

The output voltage is reflected by the auxiliary winding voltage of the Buck transformer, and both ZCS pin and VIN pin provide over voltage protection function. When the load is null or large transient happens, the output voltage will exceed the rated value. When V_{VIN} exceeds V_{VIN_OVP} or V_{ZCS} exceeds V_{ZCS_OVP} , the over voltage protection is triggered and the IC will discharge V_{VIN} by an internal current source I_{VIN_OVP} . Once V_{VIN} is below V_{VIN_OFF} , the IC will shut down and be charged again by BUS voltage through start up resistor. If the over voltage condition still exists, the system will operate in hiccup mode.

Thus, the turns of the auxiliary winding N_{AUX} and the resistor divider is related with the OVP function.

$$\frac{V_{ZCS_OVP}}{V_{OVP}} = \frac{N_{AUX}}{N_S} \times \frac{R_{ZCSD}}{R_{ZCSU} + R_{ZCSD}} \quad (8)$$

$$\frac{V_{VIN_OVP}}{V_{OVP}} \geq \frac{N_{AUX}}{N_S} \quad (9)$$

Where V_{OVP} is the output over voltage specification;

R_{ZCSU} and R_{ZCSD} compose the resistor divider. The turns ratio of N_S to N_{AUX} and the ratio of R_{ZCSU} to R_{ZCSD} could be induced from equation (8) and (9).

Short Circuit Protection (SCP)

When the output is shorted to ground, the output voltage is clamped to zero. The voltage of the auxiliary winding is proportional to the output winding, so V_{VIN} will drop down without auxiliary winding supply. Once V_{VIN} is below V_{VIN_OFF} , the IC will shut down and be charged again by the BUS voltage through the start up resistor. If the short circuit condition still exists, the system will operate in hiccup mode.

In order to guarantee SCP function not effected by voltage spike of auxiliary winding, a filter resistor R_{AUX} is needed (5Ω typically) shown in Fig.10.

Line regulation modification

The IC provides line regulation modification function to improve line regulation performance.

Due to the sample delay of ISEN pin and other internal delay, the output current increases with increasing input BUS line voltage. A small compensation voltage ΔV_{ISEN_C} is added to ISEN pin during ON time to improve such performance. This ΔV_{ISEN_C} is adjusted by the upper resistor of the divider connected to ZCS pin.

$$\Delta V_{ISEN_C} = V_{BUS} \times \frac{N_{AUX}}{N} \times \frac{1}{R_{ZCSU}} \times k_2 \quad (10)$$

Where R_{ZCSU} is the upper resistor of the divider ; k_2 is an internal constant as the modification coefficient.

The compensation is mainly related with R_{ZCSU} , larger compensation is achieved with smaller R_{ZCSU} . Normally, R_{ZCS} ranges from $100k\Omega \sim 1M\Omega$.

Then R_{ZCSD} can be selected by,

$$\frac{V_{ZCS_OVP} \times \frac{N_S}{N_{AUX}}}{V_{OUT} \times \frac{N_S}{N_{AUX}}} \times R_{ZCSU} > R_{ZCSD} \quad (11)$$

And,

$$R_{ZCSD} \geq \frac{V_{ZCS_OVP} \times \frac{N_S}{N_{AUX}}}{V_{OVP} \times \frac{N_S}{N_{AUX}}} \times R_{ZCSU} \quad (12)$$

Where V_{OVP} is the output over voltage protection specification; V_{OUT} is the rated output voltage; R_{ZCSU} is the upper resistor of the divider; N_S and N_{AUX} are the turns of secondary winding and auxiliary winding separately.

Dimming Mode

SY5881 supports two dimming modes: PWM dimming and analog dimming. The dimming signal is given as PWM square waveform and the output current is up to the duty cycle of the dimming signal.

Analog Dimming Mode

In Analog dimming mode, SY5881 is compatible with two dimming signal: PWM signal and 0-1.5V dimming signal, the output current is regulated by the voltage on ADIM pin.

If the dimming signal is PWM signal, it is given to PWM pin. When the voltage of PWM pin is higher than V_{PWM_ON} , the dimming signal is sensed as high logic level, and ADIM pin is pulled up to 1.5V by a $10k\Omega$ resistor; when the voltage is lower than V_{PWM_OFF} , the dimming signal is sensed as low logic level, and ADIM pin is pulled down to GND by a $10k\Omega$ resistor. The duty cycle of the dimming signal D_{DIM} is reflected by the voltage on ADIM pin V_{ADIM} .

$$V_{ADIM} = D_{DIM} \times 1.5V \quad (13)$$

When V_{ADIM} is lower than 37mV (D_{DIM} is 2.5%), the output current is zero; When V_{ADIM} is from V_{ADIM_ON} to 75mV (D_{DIM} is from 2.5% to 5.0%), the output current is 5.5% of rated output current; When V_{ADIM} is higher than 1.35V (D_{DIM} is over 90.0%), the output current is 100% of rated output current; When V_{ADIM} is in the range from 75mV to 1.35V (D_{DIM} is from 5.0% to 90.0%), I_{OUT} increases with D_{DIM} linearly from 5.5% to 100% of rated output current.

The dimming curve between output current I_{OUT} , V_{ADIM} and duty cycle of dimming signal is shown as below.

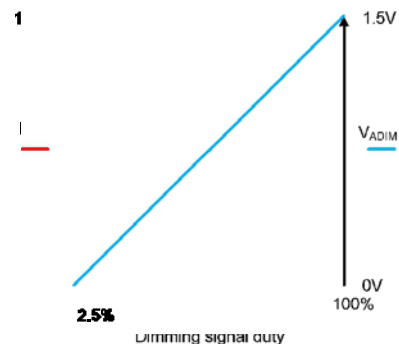

Fig.11 Dimming cure of analog dimming

A capacitor C_{ADIM} need be connected across ADIM and GND pin to obtain a smooth voltage waveform of the dimming signal duty cycle. C_{ADIM} is selected by

$$C_{ADIM} \geq \frac{10^{-3}}{f_{DIM}} \text{ F} \cdot \text{Hz} \quad (14)$$

Where f_{DIM} is the frequency of PWM dimming signal.

If the dimming signal is analog voltage, the dimming signal is given to ADIM pin directly. PWM pin should be pulled up to V_{IN} by a resistor R_{PWM} or pulled down to GND.

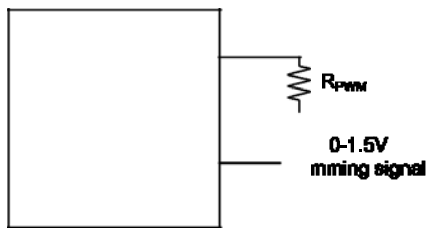

Fig.12 Connection of Analog dimming with 0-1.5V dimming signal

Power Device Design

MOSFET and Diode

When the operation condition is with maximum input voltage and full load, the voltage stress of MOSFET and output power diode is maximized;

$$V_{MOS_DS_MAX} = \sqrt{2} V_{AC_MAX} \quad (17)$$

$$V_{D_R_MAX} = \sqrt{2} V_{AC_MAX} \quad (18)$$

Where V_{AC_MAX} is maximum input AC RMS voltage. When the operation condition is with minimum input voltage and full load, the current stress of MOSFET and power diode is maximized.

Inductor (L)

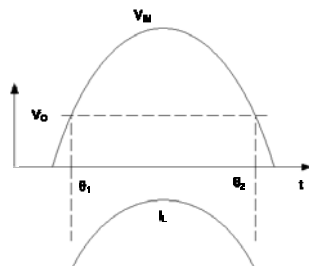

Fig.13 Input waveforms

The power is transferred from AC input to output only when the input voltage is larger than output voltage in Buck converter. The input voltage and inductor current waveforms are shown in Fig.13, where θ_1 and θ_2 are the time that input voltage is equal to output voltage.

In Quasi-Resonant mode, each switching period cycle t_S consists of three parts: current rising time t_1 , current falling time t_2 and quasi-resonant time t_3 shown in Fig.15.

The system operates in the constant on time mode to achieve high power factor. The ON time increases with the input AC RMS voltage decreasing and the load increasing. When the operation condition is with minimum input AC RMS voltage and full load, the ON time is maximized. On the other hand, when the input voltage is at the peak value, the OFF time is maximized. Thus, the minimum switching frequency f_{S_MIN} happens at the peak value of input voltage with minimum input AC

RMS voltage and maximum load condition; Meanwhile, the maximum peak current through MOSFET and the transformer happens.

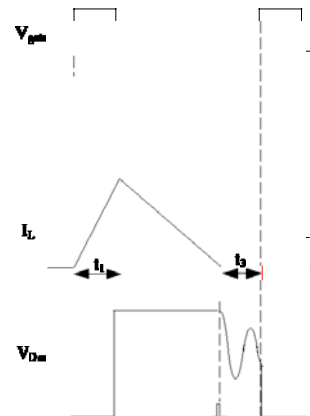

Fig.14 Switching waveforms

Once the minimum frequency f_{S_MIN} is set, the inductance of the transformer could be calculated. The design flow is shown as below:

(a) Preset minimum frequency f_{S_MIN}

(b) Compute relative t_S, t_1

$$t_S = \frac{1}{f_{S_MIN}} \quad (19)$$

$$t_1 = \frac{t_S \times (V_{OUT} + V_{DF})}{(\sqrt{2} V_{AC_MIN} + V_{DF})} \quad (20)$$

$$t_2 = t_S - t_1 \quad (21)$$

Where V_{DF} is the forward voltage of the diode

(c) Design inductance L

$$\theta_1 = \arcsin\left(\frac{V_{OUT}}{\sqrt{2}V_{AC_MIN}}\right) \times \frac{1}{\pi} \times \frac{1}{2 \times f_{AC}} \quad (22)$$

$$\theta_2 = 2 \times f_{AC} - \theta_1 \quad (23)$$

$$L = \frac{1}{\eta \times f_{AC} \times V_{OUT} \times t_1} \times \left[\sqrt{2}V_{AC_MIN} \times \frac{\cos(2\pi f_{AC} \times \theta_1) - \cos(2\pi f_{AC} \times \theta_2)}{2\pi f_{AC}} - V_{OUT} \right] \quad (24)$$

Where η is the efficiency; P_{OUT} is rated full load power;

(d) Compute inductor maximum peak current $I_{L_PK_MAX}$.

$$I_{L_PK_MAX} = \frac{\sqrt{2}V_{AC_MIN} - V_{OUT}}{L} \times t_1 \quad (25)$$

Where $I_{L_PK_MAX}$ is the maximum inductor peak current;

(f) Compute the RMS current of Buck inductor

$I_{L_RMS_MAX}$ is inductor RMS current of whole AC period

$$I_{L_RMS_MAX} = \frac{t_1}{\sqrt{3} \times L} \sqrt{V_{AC_MIN}^2 + V_{OUT}^2 - \frac{2 \times V_{AC_MIN} \times V_{OUT}}{\pi}} \quad (26)$$

(g) Compute RMS current of the MOSFET

$$I_{L_RMS_MAX} = \sqrt{\frac{t_1}{3t_s} \times \frac{t_1}{L} \sqrt{V_{AC_MIN}^2 + V_{OUT}^2 - \frac{2 \times V_{AC_MIN} \times V_{OUT}}{\pi}}} \quad (27)$$

Inductor design (N, N_{AUX})

These parameters below are necessary:

Necessary parameters	
Inductance	L
inductor maximum current	$I_{L_PK_MAX}$
inductor maximum RMS current	$I_{L_RMS_MAX}$

The design rules are as followed:

(a) Select the magnetic core style, identify the effective area A_e .

(b) Preset the maximum magnetic flux ΔB

$$\Delta B = 0.22 \sim 0.26 T$$

(c) Compute the primary turns N

$$N = \frac{L \times I}{\Delta B \times A_e} \quad (28)$$

(d) Compute the auxiliary turns N_{AUX}

$$N_{AUX} = N \times \frac{V_{VIN}}{V_{OUT}} \quad (29)$$

Where V_{VIN} is the working voltage of VIN pin (10V~11V is recommended).

(e) Select an appropriate wire diameter

With $I_{L_RMS_MAX}$, select appropriate wire to make sure the current density ranges from $4A/mm^2$ to $10A/mm^2$.

(f) If the winding area of the core and bobbin is not enough, reselect the core style, go to (a) and redesign the transformer until the ideal transformer is achieved.

Output capacitor C_{OUT}

Preset the output current ripple ΔI_{OUT} , C_{OUT} is induced by

$$C_{OUT} = \frac{2I_{OUT}}{4\pi f_{AC} R_{LED} \left(\left(\frac{\Delta I_{OUT}}{I_{OUT}} \right)^2 - 1 \right)} \quad (30)$$

Where I_{OUT} is the rated output current; ΔI_{OUT} is the demanded current ripple; f_{AC} is the input AC supply frequency; R_{LED} is the equivalent series resistor of the LED load.

Layout

(a) To achieve better EMI performance and reduce line frequency ripples, the output of the bridge rectifier should be connected to the BUS line capacitor first, then to the switching circuit.

(b) The circuit loop of all switching circuit should be kept small.

(c) The connection of ground is recommended as:

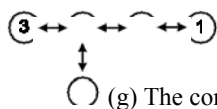

(g) The control circuit is recommended to be put outside Ground ①: ground of BUS line capacitor the power circuit loop.

Ground ②: ground of bias supply capacitor and GND pin

Ground ③: ground node of auxiliary winding

Ground ④: ground of signal trace except GND pin

Ground ⑤: ground node of current sample resistor.

(d) Bias supply trace should be connected to the bias supply capacitor first instead of GND pin. The bias supply capacitor should be put beside the IC.

(e) Loop of 'Source pin – current sample resistor – GND pin' should be kept as small as possible.

(f) The resistor divider connected to ZCS pin is recommended to be put beside the IC.

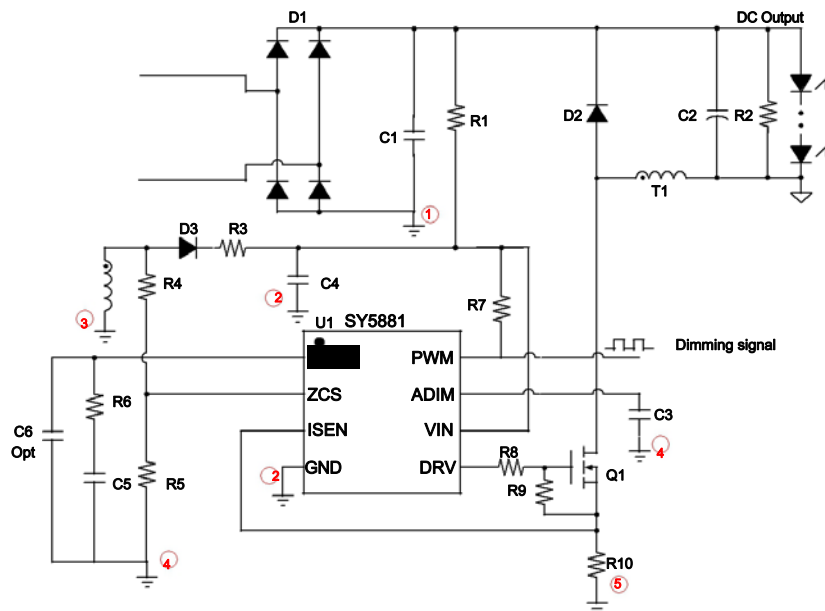

Fig.16 Ground connection recommended

Design Example

A design example of typical application is shown below step by step.

#1. Identify design specification

Design Specification			
V_{AC} (RMS)	176V~264V	V_{OUT}	24V
I_{OUT}	300mA	η	92%

#2. Inductor design (L)

Refer to Power Device Design

Conditions			
V_{AC_MIN}	176V	V_{AC_MAX}	264V
P_{OUT}	7.2W	f_{S_MIN}	46kHz

(a) f_{S_MIN} is preset

$$f_{S_MIN} = 46\text{kHz}$$

(b) Compute the switching period t_s and ON time t_1 at the peak of input voltage.

$$t_s = \frac{1}{f_{S_MIN}} = 21.74\mu\text{s}$$

$$t_1 = \frac{t_s \times (V_{OUT} + V_{DF})}{(\sqrt{2} \times V_{AC_MIN} + V_{DF})} = \frac{21.74\mu\text{s} \times (24\text{V} + 1\text{V})}{(\sqrt{2} \times 176\text{V} + 1\text{V})} = 2.17\mu\text{s}$$

$$t_2 = t_s - t_1 = 21.74\mu\text{s} - 2.17\mu\text{s} = 19.57\mu\text{s}$$

(c) Compute the inductance L

$$\theta_1 = \arcsin\left(\frac{V_{OUT}}{\sqrt{2} \times V_{AC_MIN}}\right) \times \frac{1}{\pi} \times \frac{1}{2 \times f_{AC}} = \arcsin\left(\frac{24\text{V}}{\sqrt{2} \times 176\text{V}}\right) \times \frac{1}{\pi} \times \frac{1}{2 \times 50\text{Hz}} = 3.074 \times 10^{-4} \text{ s}$$

$$\theta_2 = 2 \times f_{AC} \times t_1 - \theta_1 = 2 \times 50\text{Hz} \times 2.17\mu\text{s} - 3.074 \times 10^{-4} \text{ s} = 9.693 \times 10^{-3} \text{ s}$$

$$L = \frac{\eta \times f_{AC} \times V_{OUT} \times t_1}{P_{OUT}} \times \frac{1}{\left[\sqrt{2} \times V_{AC_MIN} \times \frac{\cos(2 \times \pi \times f_{AC} \times \theta_1) - \cos(2 \times \pi \times f_{AC} \times \theta_2)}{2 \times \pi \times f_{AC}} - V_{OUT} (\theta_2 - \theta_1) \right]}$$

$$= 0.92 \times 50\text{Hz} \times 24\text{V} \times 2.17\mu\text{s} \times \frac{1}{\left[\sqrt{2} \times 176\text{V} \times \frac{\cos(2\pi \times 50\text{Hz} \times 3.074 \times 10^{-4} \text{ s}) - \cos(2\pi \times 50\text{Hz} \times 9.693 \times 10^{-3} \text{ s})}{-3 \text{ s} - 3.074 \times 10^{-4} \text{ s}} \right] 2\pi \times 50\text{Hz}} - 24\text{V} (9.693 \times 10^{-3} \text{ s} - 3.074 \times 10^{-4} \text{ s}) \right]}$$

$$= 451\mu\text{H}$$

(d) Compute inductor maximum peak current $I_{L_PK_MAX}$.

$$I_{L_PK_MAX} = \frac{(\sqrt{2} \times V_{AC_MIN} - V_{OUT}) \times t_1}{L} = \frac{(\sqrt{2} \times 176 - 24) \times 2.17\mu\text{s}}{451\mu\text{H}} = 1.082\text{A}$$

Where $I_{L_PK_MAX}$ is the maximum inductor peak current ;

(f) Compute RMS of the inductor current $I_{L_RMS_MAX}$

$$I_{L_RMS_MAX} = \frac{t_1}{\sqrt{3} \times L} \sqrt{V_{AC_MIN}^2 + V_{OUT}^2 - \frac{4\sqrt{2}V_{AC_MIN} \times V_{OUT}}{\pi}}$$

$$= \frac{2.17\mu s}{\sqrt{3} \times 451\mu H} \sqrt{176V^2 + 24V^2 - \frac{4\sqrt{2} \times 176V \times 24V}{\pi}}$$

$$= 0.43A$$

#3. Select power MOSFET and power diode

Refer to Power Device Design

Known conditions at this step			
V_{AC_MAX}	264V	η	92%
V_{OUT}	24V		

Compute the voltage and the current stress of MOSFET:

$$I_{L_RMS_MAX} = \sqrt{\frac{t_1}{3t_s} \times \frac{t_1}{L} \sqrt{V_{AC_MIN}^2 + V_{OUT}^2 - \frac{4\sqrt{2}V_{AC_MIN} \times V_{OUT}}{\pi}}}$$

$$= \sqrt{\frac{2.17\mu s}{3 \times 21.74\mu s} \times \frac{2.17\mu s}{451\mu H} \times \sqrt{176V^2 + 24V^2 - \frac{4\sqrt{2} \times 176V \times 24V}{\pi}}}$$

$$= 0.136A$$

#4. Select the output capacitor C_{OUT}

Refer to Power Device Design

Conditions			
I_{OUT}	300mA	$\frac{\Delta I}{I_{OUT}}$	$0.3I_{OUT}$
f_{AC}	50Hz	R_{LED}	$7 \times 1.6\Omega$

The output capacitor is

$$C_{OUT} = \sqrt{\frac{\frac{\Delta I_{OUT}}{I_{OUT}}}{4\pi f_{AC} R_{LED} \left(\left(\frac{\Delta I_{OUT}}{I_{OUT}} \right)^2 - 1 \right)}}$$

$$= \sqrt{\frac{(2 \times 0.3A)^2 - 1}{0.5 \times 0.3A}}$$

$$= 4\pi \times 50Hz \times 7 \times 1.6\Omega$$

$$= 550\mu F$$

#5. Set VIN pin

Refer to Start up

Conditions			
V_{BUS_MIN}	$176V \times 1.414$	V_{BUS_MAX}	$264V \times 1.414$
I_{ST}	$15\mu A$ (typical)	V_{IN_ON}	$16V$ (typical)
I_{VIN_OVP}	$2mA$ (typical)	t_{ST}	$500ms$ (designed by user)

(a) R_{ST} is preset

$$R_{ST} < \frac{V_{BUS}}{I_{ST}} = \frac{176V \times 1.414}{15\mu A} = 16.59M\Omega,$$

$$R_{ST} > \frac{V_{BUS}}{I_{VIN_OVP}} = \frac{264V \times 1.414}{2mA} = 186.7k\Omega$$

Set R_{ST}

$$R_{ST} = 300k\Omega \times 2 = 600k\Omega$$

(b) Design C_{VIN}

$$C_{VIN} = \frac{\left(\frac{V_{BUS}}{I_{ST}} - I_{ST}\right) \times t_{ST}}{\frac{V_{VIN_ON}}{22V}} = \frac{\left(\frac{176V \times 1.414}{15\mu A} - 15\mu A\right) \times 500ms}{600k\Omega} = 8.6\mu F$$

Set C_{VIN}

$$C_{VIN} = 10\mu F$$

#6 Set COMP pin

Refer to **Internal pre-charge design for quick start up**

Parameters designed			
R_{COMP}	$1.5k\Omega$	V_{COMP_IC}	$900mV$
C_{COMP1}	$2\mu F$	C_{COMP2}	0

#7 Set current sense resistor to achieve ideal output current

Refer to **constant-current control**

Known conditions at this step			
V_{REF}	$0.3V$	I_{OUT}	$0.3A$

The current sense resistor is



$$R_S = 2 \times I_{OUT} = 2 \times 0.3A = 0.5\Omega$$

#8 set ZCS pin

Refer to **Line regulation modification** and **Over Voltage Protection (OVP) & Open Loop Protection (OLP)**

First identify R_{ZCSU} need for line regulation.

Known conditions at this step			
Parameters Designed			
R_{ZCSU}	200k Ω	K_1	68

Then compute R_{ZCSD}

Conditions			
V_{ZCS_OVP}	1.42V	V_{OVP}	35V
V_{OUT}	24V		
Parameters designed			
R_{ZCSU}	200k Ω		
N	100	N_{AUX}	45

$$\frac{N_S}{N_{AUX}} \leq \frac{V_{OVP}}{V_{OUT}}$$

$$\frac{N_S}{3 \times 12} = \frac{35}{24}$$

$$\frac{N_S}{36} \approx 1$$

$$N_S \approx 36$$

$$R_{ZCSD} < \frac{V_{ZCS_OVP}}{V_{OUT}} \times \frac{N_S}{N_{AUX}} \times R_{ZCSU}$$

$$R_{ZCSD} < \frac{1.5V}{24V} \times 1 \times 200k\Omega$$

$$R_{ZCSD} < \frac{1.15V}{24V} \times 1 \times 200k\Omega$$

$$R_{ZCSD} < 13.3k\Omega$$

R_{ZCSD} is set to

$$R_{ZCSD} = 13k\Omega$$

#9 set ADIM and PWM pin

Refer to **Analog Dimming Mode Design**

Conditions			
V_{PWM_ON}	0.8V		
Parameters Designed			
R_{PWM_UP}	200k Ω		

$$C_{ADIM} = \frac{10^{-3}}{f_{PWM}} F \times Hz = \frac{10^{-3}}{1000} F = 1\mu F$$

Hence C_{ADIM} is set to

$$C_{ADIM} = 1\mu F$$

#10 final result

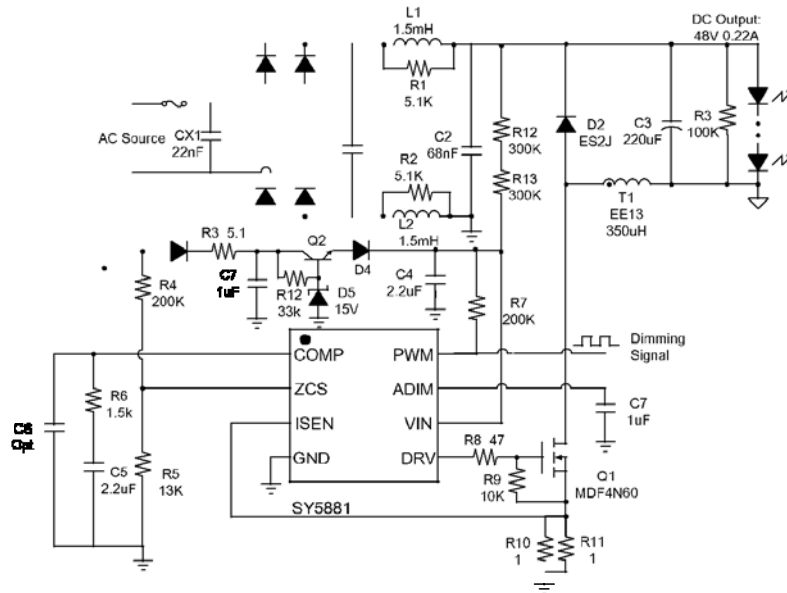

SO8 Package Outline & PCB Layout Design

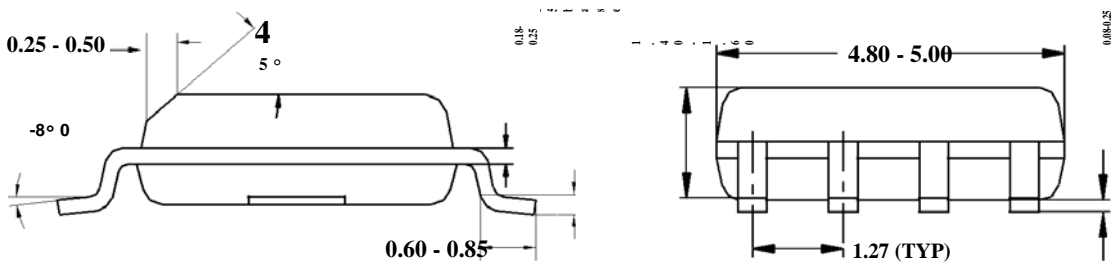
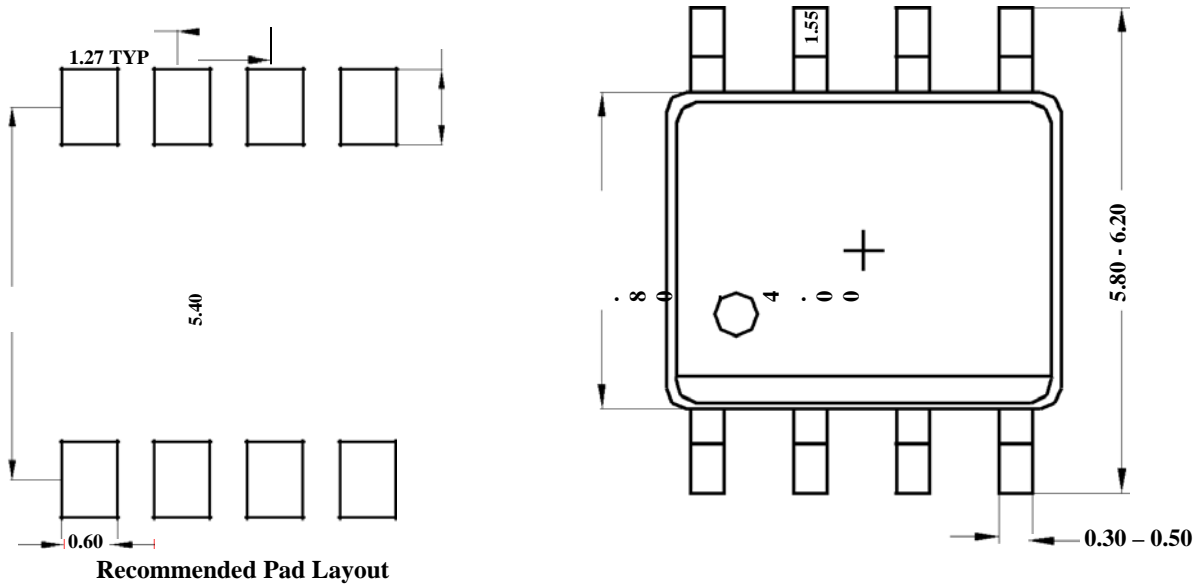

**Notes: All dimensions are in millimeters.
All dimensions don't include mold flash & metal burr.**

X-ON Electronics

Largest Supplier of Electrical and Electronic Components

Click to view similar products for [LED Display Drivers](#) category:

Click to view products by [Silergy](#) manufacturer:

Other Similar products are found below :

[STP16CPP05XTTR](#) [SCT2027CSSG](#) [KP22306WGA](#) [KP1199AWPA](#) [KP1199BWPA](#) [GN1628T](#) [BCT3236EGH-TR](#) [HT1628BRWZ](#)
[KP1192SPA](#) [KP1182SPA](#) [KP1262FSPA](#) [KP1072LSPA](#) [KP1191SPA](#) [KP18001WPA](#) [KP1070LSPA](#) [KP1221SPA](#) [KP107ALSPA](#) [GN1640T](#)
[MBI5253GP-A](#) [WS90561T](#) [S7P](#) [WS9821B](#) [S7P](#) [WS9032GS7P](#) [LYT3315D](#) [M08888G-11](#) [M08890G-13](#) [SCT2001ASIG](#) [SCT2024CSOG](#)
[SCT2024CSSG](#) [AL8400QSE-7](#) [PR4401](#) [PR4403](#) [PCA9685PW](#) [STP16CPC05XTTR](#) [WS2821B](#) [PR4402](#) [M08898G-13](#) [RT8471GJ5](#)
[TLC59482DBQR](#) [ISL97634IRT14Z-TK](#) [AW36413CSR](#) [LP5562TMX](#) [WS2818B](#) [BCR401R](#) [BCR401U](#) [BCR402U](#) [SCT2004CSOG](#)
[SCT2026CSOG](#) [SCT2026CSSG](#) [SCT2932F](#) [SCT2932J](#)