

General Description

The SY59103P is a linear AC/DC driver with integrated 350V MOSFET for LED lighting. It's compatible with Leading/Trailing edge dimmer. The patented technique results in high efficiency and power factor.

Ordering Information

SY59103 □(□□)□
 └───┬───┬───
 Temperature Code
 Package Code
 Optional Spec Code

Ordering Number	Package type	Note
SY59103PFCC	SO8E	----

Features

- Compatible with Leading/Trailing Edge Dimmer
- Integrated 350V MOSFET
- Power Factor >0.9
- SMT Assembly
- Eliminate Magnetic Components
- Compact Package: SO8E

Applications

- LED Lighting
- Down Light/Bulb/Spot Lamp

Typical Applications

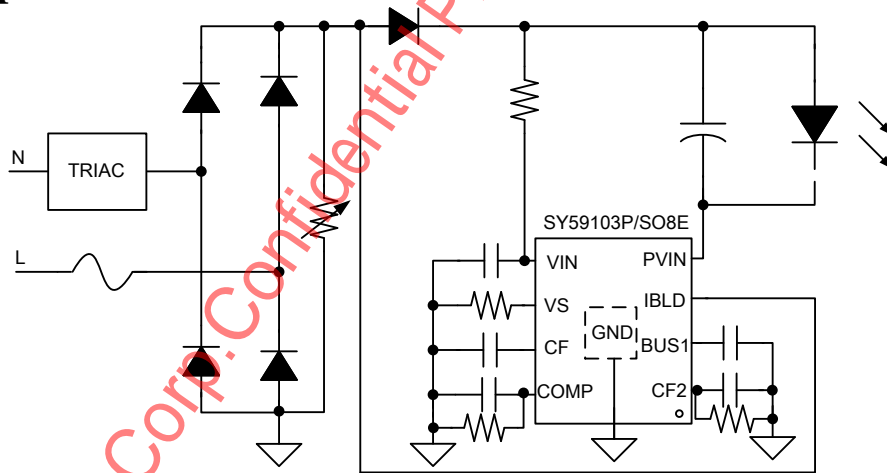
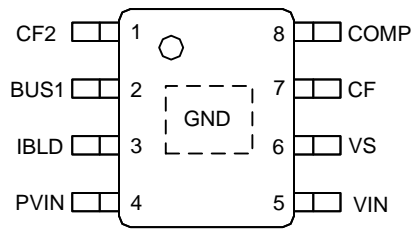

Fig1. Typical application

Pinout (top view)



(SO8E)

Top Mark: BTJxyz (device code: BTJ, x=year code, y=week code, z=lot number code)

Pin	Name	Description
1	CF2	TRIAC or Non TRIAC mode detection.
2	BUS1	Connect a 2.2nF to GND.
3	IBLD	Bleeding current from BUS to achieve good compatibility.
4	PVIN	Drain of integrated power MOSFET.
5	VIN	IC power supply.
6	VS	Source of integrated power MOSFET integrate, sense output current.
7	CF	TRIAC angle detection.
8	COMP	Loop compensation Pin.
Bottom	GND	GND of IC.

Block Diagram

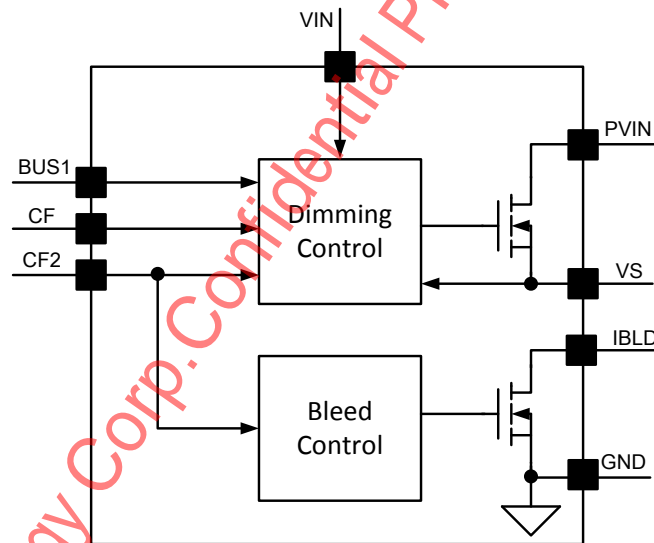

Fig2. IC block diagram

Absolute Maximum Ratings (Note 1)

PVIN	-----	-0.3V to 350V
IBLD	-----	-0.3V to 600V
COMP, BUS1	-----	-0.3V to 25V
CF, CF2, VS	-----	-0.3V to 3.6V
VIN	-----	-0.3V to 21V
Supply current I _{VIN}	-----	10mA
Power Dissipation, @ T _A = 25°C SO8E	-----	3.3W
Package Thermal Resistance (Note 2)		
SO8E, θ _{JA}	-----	30°C/W
SO8E, θ _{JC}	-----	10°C/W
Temperature Range	-----	-40°C to 150°C
Lead Temperature (Soldering, 10 sec.)	-----	260°C
Storage Temperature Range	-----	-65°C to 150°C

Recommended Operating Conditions (Note 3)

VIN	-----	12V~18V
-----	-------	---------

Silergy Corp. Confidential Prepared For HG

Electrical Characteristics

($V_{IN} = 15V$ (Note 3), $T_A = 25^\circ C$ unless otherwise specified)

Parameter	Symbol	Test Conditions	Min	Typ	Max	Unit
Power Supply Section						
VIN Turn-on Threshold	V_{VIN_ON}		15	17.5	20	V
VIN Turn-off Threshold	V_{VIN_OFF}		9.5	11.5	13.5	V
Quiescent Current	I_Q		210	255	320	μA
Internal Reference Voltage	V_{REF}		274	281	288	mV
BV of Integrated MOSFET	V_{Drain}		350			V
Thermal Section						
Thermal Fold Back Temperature	T_{FB}			150		$^\circ C$
Thermal Shutdown Temperature	T_{SD}			160		$^\circ C$

Note 1: Stresses beyond the “Absolute Maximum Ratings” may cause permanent damage to the device. These are stress ratings only. Functional operation of the device at these or any other conditions beyond those indicated in the operational sections of the specification is not implied. Exposure to absolute maximum rating conditions for extended periods may affect device reliability.

Note 2: θ_{JA} is measured in the natural convection at $T_A = 25^\circ C$ on a low effective single layer thermal conductivity test board of JEDEC 51-3 thermal measurement standard. Test condition: Device mounted on 2” x 2” FR-4 substrate PCB, 2oz copper, with minimum recommended pad on top layer and thermal vias to bottom layer ground plane.

Note 3: Increase VIN pin voltage gradually higher than V_{VIN_ON} voltage then turn down to 15V.

Silergy Corp. Confidential- Prepared for Customer Use Only

Operation

The SY59103P is a dimmable linear AC/DC driver with integrated 350V MOSFET for LED lighting.

It's compatible with Leading/Trailing edge dimmer.

With the constant current control, SY59103P can achieve good line regulation and load regulation.

The patented technique leads to high power efficiency and PF (>0.9).

SY59103P provides reliable protections such as over temperature protection (Thermal fold-back), etc.

SY59103P is available with SO8E package.

Applications Information

Start Up and IC Power Supply

After AC supply is powered on, C_{VIN} is charged up by BUS voltage through a start up resistor R_{ST} . Once V_{VIN} exceeds V_{VIN_ON} , IC starts to work and R_{ST} supplies IC operation current.

The startup procedure is shown in Fig.3.

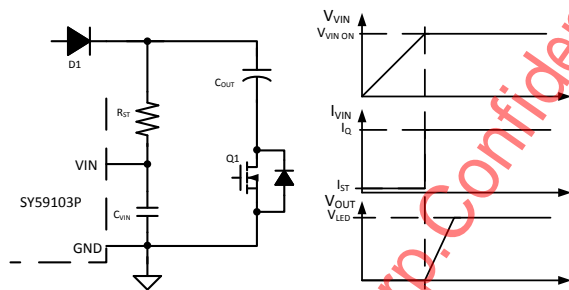

Fig.3 Start up

Shut Down

After AC supply is powered off, the energy stored in the output capacitor will be discharged. When V_{VIN} is below V_{VIN_UVLO} , the IC will stop working and V_{COMP} will be discharged to zero.

Constant-Current Control

The output current I_{OUT} can be represented by

$$I_{OUT} = \frac{V_{REF}}{R_S}$$

Where V_{REF} is the internal reference voltage; R_S is the current sense resistor.

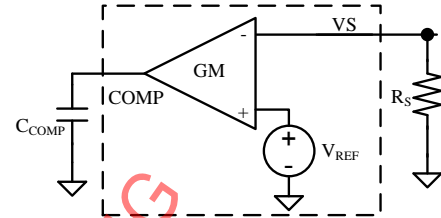

Fig.4 Closed loop

Output capacitor C_{COMP} need to be big enough to keep average output current is equal to V_{REF} .

Special Design for Current Compensation

To have a better efficiency, special design is integrated in SY59103P.

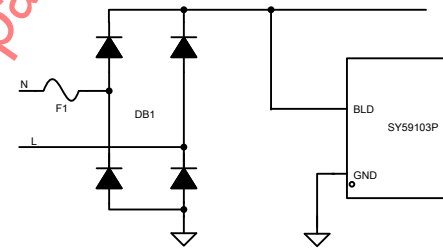

Fig.5 The patented technology of compensation

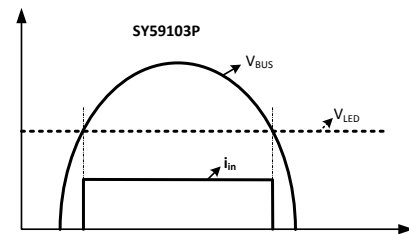

Fig.6 Shape of Input current for high PF

Input current of SY59103P is constant when V_{BUS} higher than V_{LED} , set V_{LED} about 115V, it is just right for the requirement PF>0.9.

TRIAC Dimming

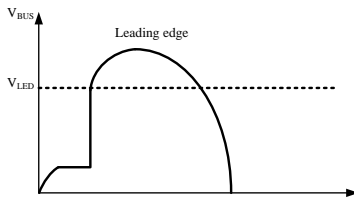

Fig.7 BUS voltage with TRIAC

When cooperate with dimmer, IC will provide enough latching current and holding to keep dimmer working normally.

Thermal Fold-back Function

SY59103P have thermal fold-back function.

Design Guide:

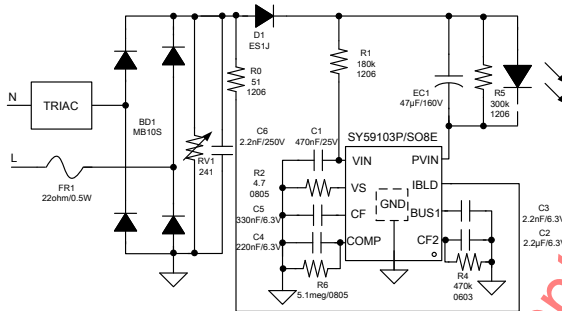

Fig.8 Schematic

1: Power Supply Module:

R1 and C1 is start up and power supply module:

(a) Power supply of SY59103P is from R₁ (by D1 and EC1), and maximum operation current is I_{Q_MAX}. Consider of operating condition and power loss, 180KΩ is recommended.

$$R_S < \frac{V_{OUT_MIN} - V_{VIN_UVLO}}{I_{Q_MAX}} = \frac{80V - 11.5V}{320\mu A} = 214K$$

(b) Consider ripple on C_{VIN} and IC supply voltage is about 18V, C_{VIN} is recommended 470nF/25V.

2: Sense Resistor

Inter Ref is 281mV, R_S=281mV/I_{OUT}. As connect a 5.1meg resistor between COMP and GND, R_S need to relect around the result calculated.

3: Output Electrolytic Capacitor

According to output current ripple requirement, usually, when select 47μF electrolytic capacitor, output ripple is around ± 25% I_{OUT}, when select 22μF electrolytic capacitor, output ripple is around ± 45% I_{OUT}.

4: C_{COMP} Selection

Consider of PF and loop response speed, C_{COMP} is suggested 220~330nF (If PF is not requested higher than 0.9, then C_{COMP} can chose 68nF~100nF).

5: C_{CF} Selection

CF is use for TRIAC angle detection, on other way, the duty V_S>V_{S_LOW}, by filtering the angle and change reference inter according to V_{CF}. C_{CF} is suggested 220nF~470nF.

6: C_{CF2} Selection

CF2 is use for TRIAC or non TRIAC detection, 2.2μF is recommended for C_{CF2}, usually a resistor is paralleled between CF2 and GND.

7: C_{BUS1} Selection

BUS1 is an internal compensation PIN, a 2.2nF compensatory capacitor is recommended to connect between BUS1 and GND.

SO8E Package Outline & PCB layout

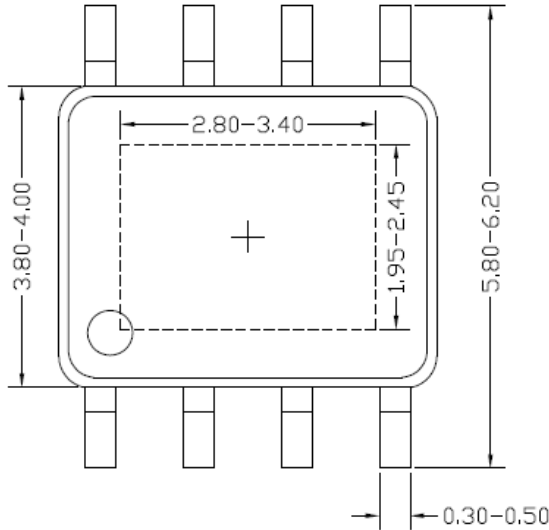

Top view

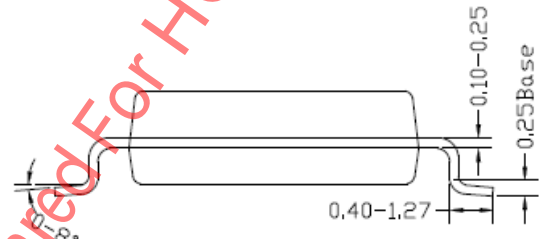

Side view

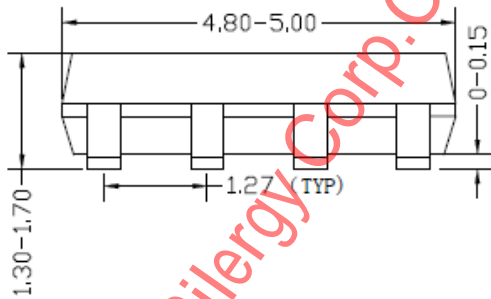

Front view

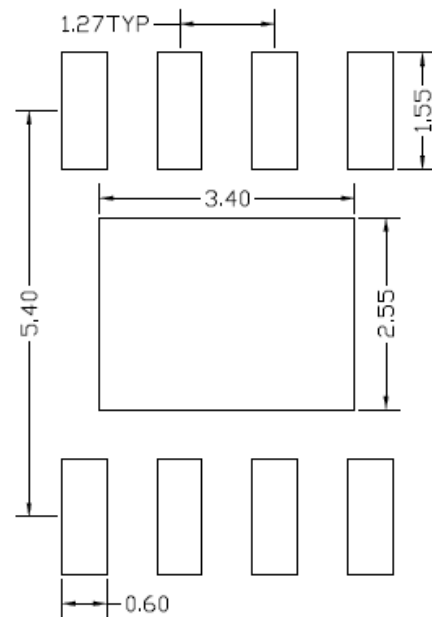

**Recommended PCB Layout
(Reference Only)**

Notes: All dimension in millimeter and exclude mold flash & metal burr.

Taping & Reel Specification

1. Taping orientation

SO8E

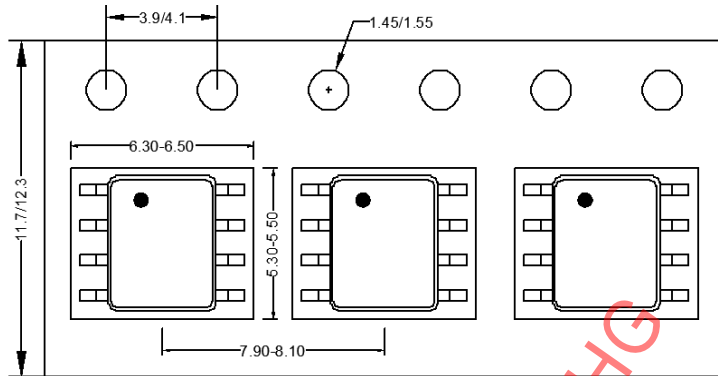

Feeding direction →

2. Carrier Tape & Reel specification for packages

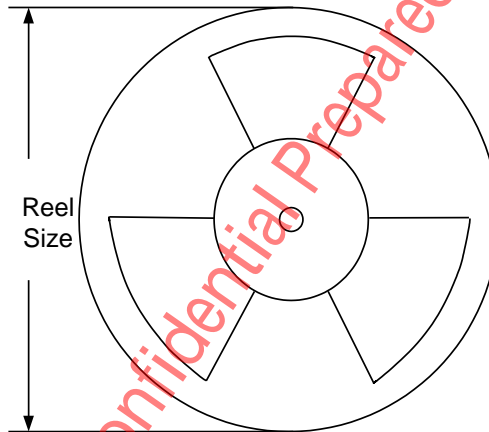

Package types	Tape width (mm)	Pocket pitch(mm)	Reel size (Inch)	Trailer * length(mm)	Leader * length (mm)	Qty per reel (pcs)
SO8E	12	8	13"	400	400	2500

Others: NA

IMPORTANT NOTICE

1. **Right to make changes.** Silergy and its subsidiaries (hereafter Silergy) reserve the right to change any information published in this document, including but not limited to circuitry, specification and/or product design, manufacturing or descriptions, at any time and without notice. This document supersedes and replaces all information supplied prior to the publication hereof. Buyers should obtain the latest relevant information before placing orders and should verify that such information is current and complete. All semiconductor products are sold subject to Silergy's standard terms and conditions of sale.
2. **Applications.** Application examples that are described herein for any of these products are for illustrative purposes only. Silergy makes no representation or warranty that such applications will be suitable for the specified use without further testing or modification. Buyers are responsible for the design and operation of their applications and products using Silergy products. Silergy or its subsidiaries assume no liability for any application assistance or designs of customer products. It is customer's sole responsibility to determine whether the Silergy product is suitable and fit for the customer's applications and products planned. To minimize the risks associated with customer's products and applications, customer should provide adequate design and operating safeguards. Customer represents and agrees that it has all the necessary expertise to create and implement safeguards which anticipate dangerous consequences of failures, monitor failures and their consequences, lessen the likelihood of failures that might cause harm and take appropriate remedial actions. Silergy assumes no liability related to any default, damage, costs or problem in the customer's applications or products, or the application or use by customer's third-party buyers. Customer will fully indemnify Silergy, its subsidiaries, and their representatives against any damages arising out of the use of any Silergy components in safety-critical applications. It is also buyers' sole responsibility to warrant and guarantee that any intellectual property rights of a third party are not infringed upon when integrating Silergy products into any application. Silergy assumes no responsibility for any said applications or for any use of any circuitry other than circuitry entirely embodied in a Silergy product.
3. **Limited warranty and liability.** Information furnished by Silergy in this document is believed to be accurate and reliable. However, Silergy makes no representation or warranty, expressed or implied, as to the accuracy or completeness of such information and shall have no liability for the consequences of use of such information. In no event shall Silergy be liable for any indirect, incidental, punitive, special or consequential damages, including but not limited to lost profits, lost savings, business interruption, costs related to the removal or replacement of any products or rework charges, whether or not such damages are based on tort or negligence, warranty, breach of contract or any other legal theory. Notwithstanding any damages that customer might incur for any reason whatsoever, Silergy's aggregate and cumulative liability towards customer for the products described herein shall be limited in accordance with the Standard Terms and Conditions of Sale of Silergy.
4. **Suitability for use.** Customer acknowledges and agrees that it is solely responsible for compliance with all legal, regulatory and safety-related requirements concerning its products, and any use of Silergy components in its applications, notwithstanding any applications-related information or support that may be provided by Silergy. Silergy products are not designed, authorized or warranted to be suitable for use in life support, life-critical or safety-critical systems or equipment, nor in applications where failure or malfunction of an Silergy product can reasonably be expected to result in personal injury, death or severe property or environmental damage. Silergy assumes no liability for inclusion and/or use of Silergy products in such equipment or applications and therefore such inclusion and/or use is at the customer's own risk.
5. **Terms and conditions of commercial sale.** Silergy products are sold subject to the standard terms and conditions of commercial sale, as published at <http://www.silergy.com/stdterms>, unless otherwise agreed in a valid written individual agreement specifically agreed to in writing by an authorized officer of Silergy. In case an individual agreement is concluded only the terms and conditions of the respective agreement shall apply. Silergy hereby expressly objects to and denies the application of any customer's general terms and conditions with regard to the purchase of Silergy products by the customer.
6. **No offer to sell or license.** Nothing in this document may be interpreted or construed as an offer to sell products that is open for acceptance or the grant, conveyance or implication of any license under any copyrights, patents or other industrial or intellectual property rights. Silergy makes no representation or warranty that any license, either express or implied, is granted under any patent right, copyright, mask work right, or other intellectual property right. Information published by Silergy regarding third-party products or services does not constitute a license to use such products or services or a warranty or endorsement thereof. Use of such information may require a license from a third party under the patents or other intellectual property of the third party, or a license from Silergy under the patents or other intellectual property of Silergy.

For more information, please visit: www.silergy.com

© 2018 Silergy Corp.

All Rights Reserved.

X-ON Electronics

Largest Supplier of Electrical and Electronic Components

Click to view similar products for [Switching Voltage Regulators](#) category:

Click to view products by [Silergy](#) manufacturer:

Other Similar products are found below :

[FAN53610AUC33X](#) [FAN53611AUC123X](#) [EN6310QA](#) [160215](#) [R3](#) [KE177614](#) [FAN53611AUC12X](#) [MAX809TTR](#) [NCV891234MW50R2G](#)
[AST1S31PUR](#) [NCP81203PMNTXG](#) [NCP81208MNTXG](#) [PCA9412AUKZ](#) [NCP81109GMNTXG](#) [NCP3235MNTXG](#) [NCP81109JMNTXG](#)
[NCP81241MNTXG](#) [NTE7223](#) [NTE7222](#) [NTE7224](#) [L6986FTR](#) [MPQ4481GU-AEC1-P](#) [MP8756GD-P](#) [MPQ2171GJ-P](#) [MPQ2171GJ-AEC1-P](#)
[N JW4153U2-A-TE2](#) [MP2171GJ-P](#) [MP28160GC-Z](#) [MPM3509GQVE-AEC1-P](#) [XDPE132G5CG000XUMA1](#) [LM60440AQRPKRQ1](#)
[MP5461GC-P](#) [IW673-20](#) [MPQ4409GQBE-AEC1-P](#) [S-19903DA-A8T1U7](#) [S-19903CA-A6T8U7](#) [S-19903CA-S8T1U7](#) [S-19902BA-A6T8U7](#)
[S-19902CA-A6T8U7](#) [S-19902AA-A6T8U7](#) [S-19903AA-A6T8U7](#) [S-19902AA-S8T1U7](#) [S-19902BA-A8T1U7](#) [AU8310](#)
[LMR23615QDRRRQ1](#) [LMR33630APAQRNXRQ1](#) [LMR33630APCQRNXRQ1](#) [LMR36503R5RPER](#) [LMR36503RFRPER](#)
[LMR36503RS3QRPERQ1](#)