

General Description

SY59112A2/B4 is a linear LED driver for HV TRIAC with integrated 500V power MOSFET and 700V bleeder MOSFET. It uses special technology to achieve high PF and efficiency performance. Special logic functions are added to achieve good compatibility with TRIAC dimmer. It's integrated a current ripple remover to eliminate low frequency current ripple and no additional electrical design is needed.

Ordering Information

Ordering Number	Package type	Note
SY59112A2FCP	SO8E	----
SY59112B4FCP	SO8E	----

Features

- Compatible with HV TRIAC Dimmer
- Integrated: 500V Main MOS and 700V Bleeder MOS
- Latching Current is Adjustable
- Regulator for Adaptive 100/120Hz Current Ripple Remove
- Special Low Power Loss Control
- High PF: PF>0.7
- No Magnetic Components and Support All Components Surface Mounted
- Compact Package: SO8E

Applications

- LED Lighting

Part Number	Output current	Zener voltage of ripple remover
SY59112A2	>16mA & <30mA	11.5V
SY59112B4	>12mA & <20mA	18V

Typical Applications

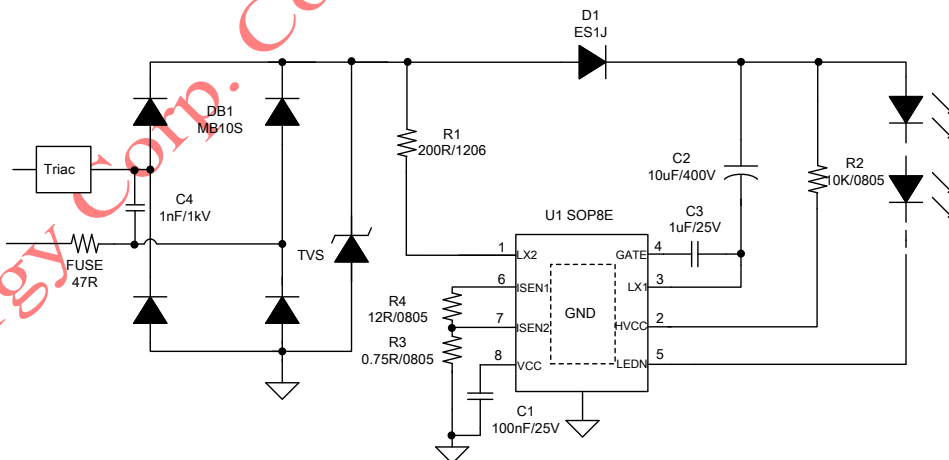
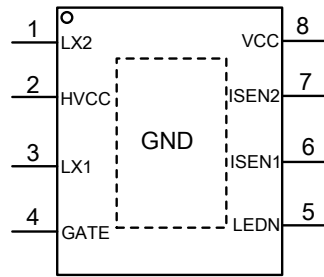

Figure.1 Typical application

Pinout (top view)



(SO8E)

Part Number	Package type	Top Mark [Ⓞ]
SY59112A2FCC	SO8E	EDQxyz
SY59112B4FCC	SO8E	EDRxyz

Note ①: x=year code, y=week code, z= lot number code

Pin Name	Pin number	Pin Description
LX2	1	Drain of Bleeding MOS pin.
HVCC	2	HV power supply pin.
LX1	3	Drain of Main MOS pin.
GATE	4	Gate of integrated current ripple remover MOSFET.
LEDN	5	Connect to the Cathode of LED load.
ISEN1	6	Main MOS Current Sense Pin. The output current is decided by $I_{OUT} = \frac{V_{REF}}{R_{ISEN1} + R_{ISEN2}}$
ISEN2	7	BLD MOS Current Sense Pin. Latching current is adjusted by R _{ISEN2} . Recommended value: R _{ISEN2} > 0.75 ohm.
VCC	8	Power supply pin.
GND	9	Ground.

Absolute Maximum Ratings (Note 1)

LX2, HVCC	-0.3V~700V
LX1, GATE, LEDN	-0.3V~500V
ISEN1, ISEN2	-0.3V~3.6V
VCC	-0.3~ 25V
LEDN to LX1	-0.3~ 20V
GATE to LX1	-0.3~ 3.6V
Power Dissipation, @ $T_A = 25\text{ }^\circ\text{C}$ SO8E	3.3W
Package Thermal Resistance (Note 2)	
SO8E, θ_{JA}	
30 $^\circ\text{C}/\text{W}$	
SO8E, θ_{JC}	10 $^\circ\text{C}/\text{W}$
Junction Temperature Range	-40 $^\circ\text{C}$ to 150 $^\circ\text{C}$
Lead Temperature (Soldering, 10 sec.)	260 $^\circ\text{C}$
Storage Temperature Range	-65 $^\circ\text{C}$ to 150 $^\circ\text{C}$

Recommended Operating Conditions (Note 3)

Junction Temperature Range	-40 $^\circ\text{C}$ to 150 $^\circ\text{C}$
Ambient Temperature Range	-40 $^\circ\text{C}$ to 120 $^\circ\text{C}$

Block Diagram

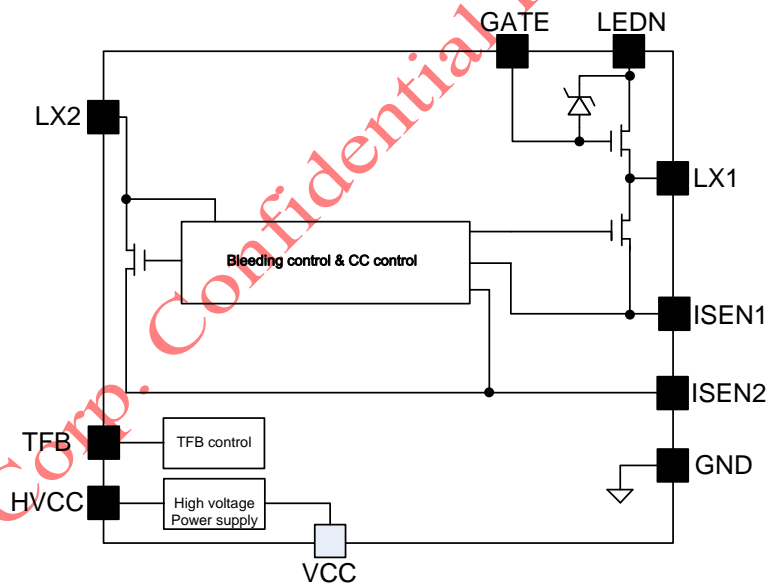

Figure.3 Block Diagram

Electrical Characteristics

($V_{IN} = 15V$ (Note 3), $T_A = 25^\circ C$ unless otherwise specified)

Parameter	Symbol	Test Conditions	Min	Typ	Max	Unit
Power Supply Section						
VIN Turn-on Threshold	V_{VIN_ON}			12		V
VIN Turn-off Threshold	V_{VIN_OFF}			8.8		V
Quiescent Current	I_Q			350		μA
Error Amplifier Section						
Internal Reference Voltage	V_{REF}			0.3		V
MOS Section						
BV of LX1 MOS	V_{BV_LX1}		500			V
BV of LX2 MOS	V_{BV_LX2}		700			V
Inter Ripple Remover Section						
Zener Voltage between LEDN and GATE of SY59112A2	V_{Zener}			11.5		V
Zener Voltage between LEDN and GATE of SY59112B4	V_{Zener}			18		V
Thermal Section						
Thermal Foldback Temperature	T_{FB}			155		$^\circ C$

Note 1: Stresses beyond the “Absolute Maximum Ratings” may cause permanent damage to the device. These are stress ratings only. Functional operation of the device at these or any other conditions beyond those indicated in the operational sections of the specification is not implied. Exposure to absolute maximum rating conditions for extended periods may affect device reliability.

Note 2: Θ_{JA} is measured in the natural convection at $T_A = 25^\circ C$ on a low effective single layer thermal conductivity test board of JEDEC 51-3 thermal measurement standard. Test condition: Device mounted on 2” x 2” FR-4 substrate PCB, 2oz copper, with minimum recommended pad on top layer and thermal vias to bottom layer ground plane.

Note 3: Increase VIN pin voltage gradually higher than V_{VIN_ON} voltage then turn down to 12V.

SO8E Package Outline & PCB layout

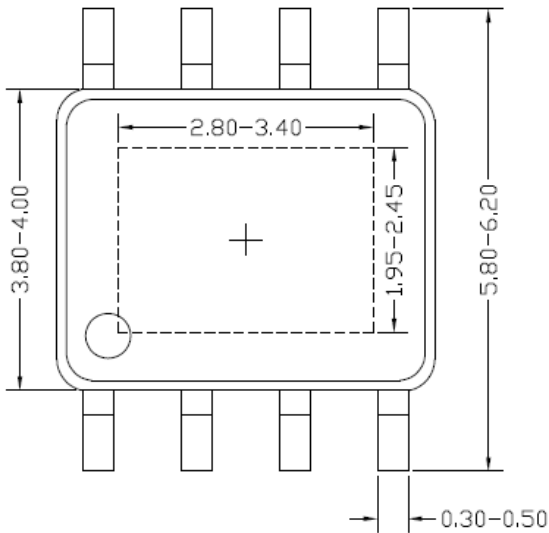

Top view

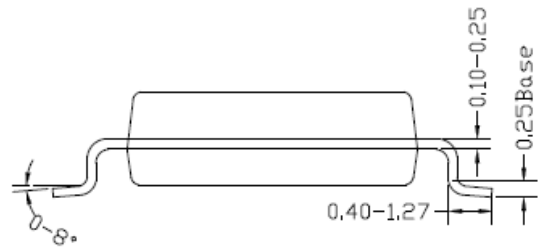

Side view

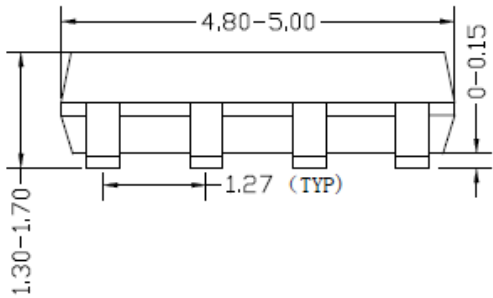

Front view

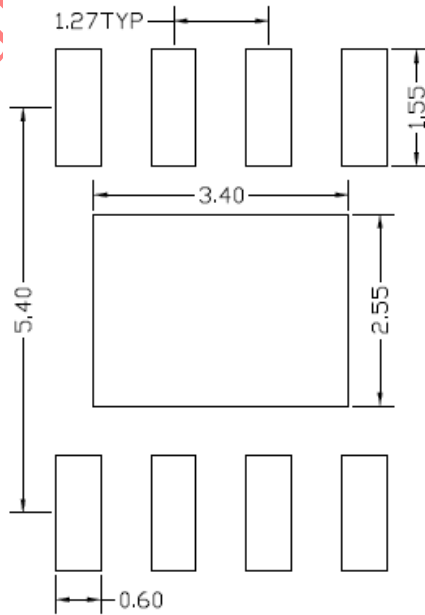

Recommended PCB Layout
(Reference Only)

Notes: All dimension in millimeter and exclude mold flash & metal burr.

X-ON Electronics

Largest Supplier of Electrical and Electronic Components

Click to view similar products for [LED Display Drivers](#) category:

Click to view products by [Silergy](#) manufacturer:

Other Similar products are found below :

[STP16DP05PTR](#) [MP3370GN-Z](#) [ISL97631IHTZ-T7A](#) [ISL97632IRT26Z-T](#) [LV5026MC-AH](#) [IK62083DWT](#) [OB3655TAP-H](#) [OB3399PAP](#)
[AW36514FCR](#) [AW36428FCR](#) [KAQW214A TL](#) [TM1629\(TA2009B\)](#) [WS2814F](#) [XB402U-L27](#) [HT16K33A-20SOP](#) [HT16D33A-28SSOP](#)
[TM1628E](#) [TM512AE0](#) [TM512AD](#) [TM0822B](#) [SY7310AADC](#) [SY58863FAC](#) [SY5863AJAC](#) [FM4115K](#) [TM1638N-SOP28-TA1319B](#)
[SPL5013CNI-TRG](#) [AW21024QNR](#) [AW36423FCR](#) [AW36515FCR](#) [AW99703CSR](#) [AW21036QNR](#) [AW21009QNR](#) [AW20108QNR](#)
[AW2016AQNR](#) [AW9967DNR](#) [PT4115BE89E](#) [CC1108ST](#) [CC1109](#) [SD6800BCTR](#) [SDH7612DH](#) [HT16D35A-48LQFP-EP](#) [HT1635C-](#)
[64LQFP-7*7](#) [HT1632D-52LQFP-2.0](#) [HT16K33A-28SOP](#) [HT16D31A-16NSOP-EP](#) [TLD5099EP](#) [BCR 431U](#) [IS32FL3740-ZLA3-TR](#)
[PAM2804AAB010\(MS\)](#) [OB3379ZCPA-D](#)