



Application Note: SY6280/SY6280A

5.5V, 2A Low Loss Power Distribution Switch

General Description

SY6280/ SY6280A is ultra-low $R_{DS(ON)}$ switch with programmable current limit to protect the power source from over current and short circuit conditions. They incorporate over temperature protection and reverse blocking functions. SY6280 automatically discharges the output capacitors during shutdown.

Ordering Information

SY6280□(□□)□

- Temperature Code
- Package Code
- Optional Spec Code

Ordering Number	Package type	Note
SY6280AAC	SOT23-5	----
SY6280AAAC	SOT23-5	----

Features

- Input voltage: 2.4V to 5.5V
- 2A load current capability
- Programmable current limit
- Enable polarity: active high
- Over temperature protection
- Reverse blocking (no body diode)
- OUT can be forced higher than IN at shutdown
- Output discharge function
 - ◇ SY6280: Auto output discharge function
 - ◇ SY6280A: No output discharge function
- Compact SOT23-5 package minimizes the board space

Applications

- USB 3G Datacard
- USB Dongle
- MiniPCI Accessories

Typical Applications

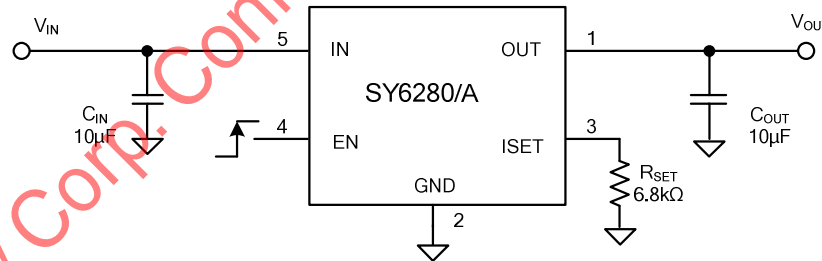
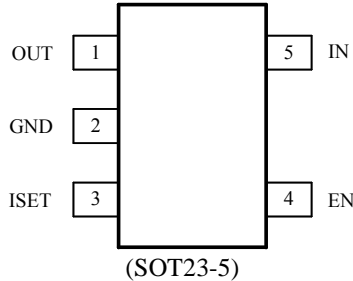

Figure 1. Schematic Diagram(1A current limit)



SY6280/SY6280A

Pinout (top view)



Top mark: **CO**xyz for SY6280 (Device code: CO, x=year code, y=week code, z=lot number code)

QWxyz for SY6280A (Device code: QW, x=year code, y=week code, z=lot number code)

Pin Name	Pin number	Pin Description
IN	5	Input pin, decoupled with a 10 μ F capacitor to GND
GND	2	Ground pin
OUT	1	Output pin, decoupled with a 10 μ F capacitor to GND
EN	4	ON/OFF control. Pull high to enable IC. Do not leave it floating
ISET	3	Current limit programming pin. Connect a resistor R _{SET} from this pin to ground to program the current limit: I _{LM} (A)=6800/R _{SET} (Ω)

Absolute Maximum Ratings (Note 1)

All pins	-0.3V to 6V
Power Dissipation, P _D @ T _A = 25°C SOT23-5,	0.6W
Package Thermal Resistance (Note 2)	
θ_{JA}	200°C/W
θ_{JC}	130°C/W
Junction Temperature	150°C
Lead Temperature (Soldering, 10 sec.)	260°C
Storage Temperature Range	-65°C to 150°C
ESD Susceptibility (Note 2)	
HBM (Human Body Mode)	2kV
MM (Machine Mode)	200V

Recommended Operating Conditions (Note 3)

IN	2.4V to 5.5V
All other pins	0V to 5.5V
Junction Temperature Range	-40°C to 125°C
Ambient Temperature Range	-40°C to 85°C



SY6280/SY6280A

Block Diagram

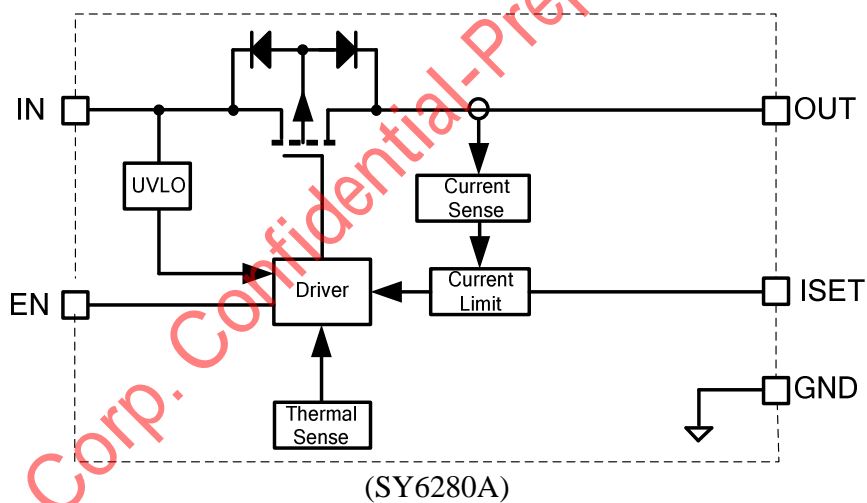
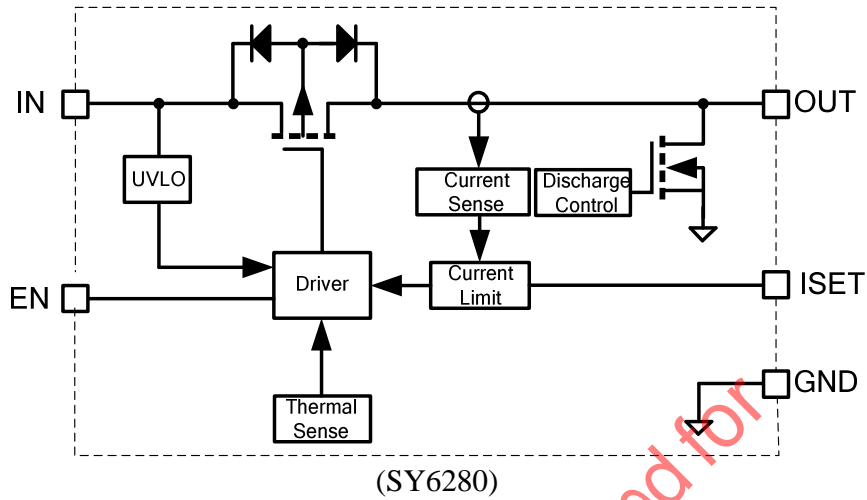



SY6280/SY6280A

Electrical Characteristics

($V_{IN} = 5V$, $C_{OUT} = 10\mu F$, $T_A = 25^\circ C$ unless otherwise specified)

Parameter	Symbol	Test Conditions	Min	Typ	Max	Unit
Input Voltage Range	V_{IN}		2.4		5.5	V
Shutdown Input Current	I_{SHDN}	Open load, IC Disabled.		0.2	1	μA
Quiescent Supply Current	I_Q	Open load, IC Enabled.		38		μA
FET RON	$R_{DS(ON)}$			63		m Ω
EN Rising Threshold	$V_{EN(H)}$		2			V
EN Falling Threshold	$V_{EN(L)}$				0.8	V
EN Leakage Current	I_{EN}	$V_{EN} = 5.0V$			1	μA
IN UVLO Threshold	V_{IN_UVLO}				2.3	V
IN UVLO Hysteresis	V_{IN_HYS}			0.1		V
Over Current Limit	I_{LIM}	$R_{SET} = 6.8k\Omega$	0.75	1	1.25	A
	$I_{LIM(min)}$			0.4		A
Turn-on Time	T_{ON}	$R_L = 10\Omega$, $C_{OUT} = 1\mu F$		130		μs
Turn-off Time	T_{OFF}	$R_L = 10\Omega$, $C_{OUT} = 1\mu F$		20		μs
OUT Shutdown Discharge Resistance	R_{DIS}	SY6280 Only		120		Ω
Thermal Shutdown Temperature	T_{SD}			130		$^\circ C$
Thermal Shutdown Hysteresis				20		$^\circ C$

Note 1: Stresses beyond the “Absolute Maximum Ratings” may cause permanent damage to the device. These are stress ratings only. Functional operation of the device at these or any other conditions beyond those indicated in the operational sections of the specification is not implied. Exposure to absolute maximum rating conditions for extended periods may affect device reliability.

Note 2: θ_{JA} is measured in the natural convection at $T_A = 25^\circ C$ on a low effective single layer thermal conductivity test board of JEDEC 51-3 thermal measurement standard. Pin 2 of SOT23-5 packages is the case position for θ_{JC} measurement.

Note 3: The device is not guaranteed to function outside its operating conditions.



Typical Operating Characteristics

$R_{DS(ON)}$ vs Input Voltage

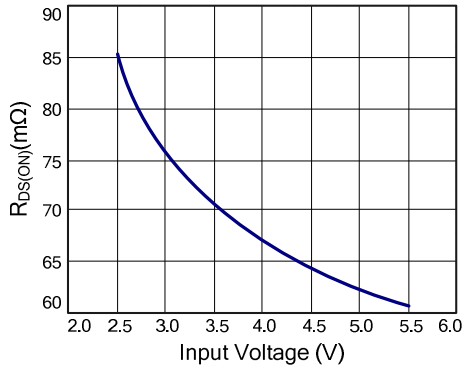

Supply Current vs Input Voltage

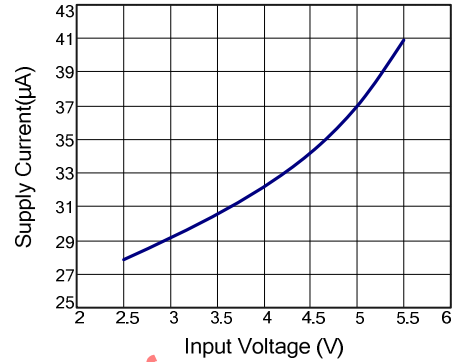

I_{LIM} vs R_{SET}

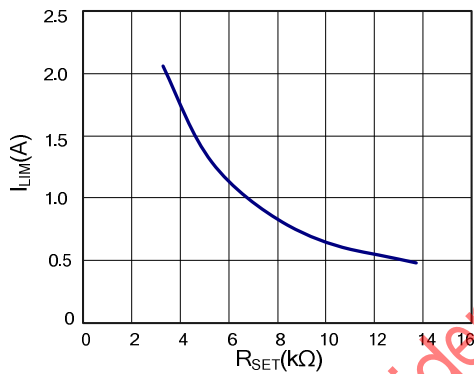

UVLO at Rising

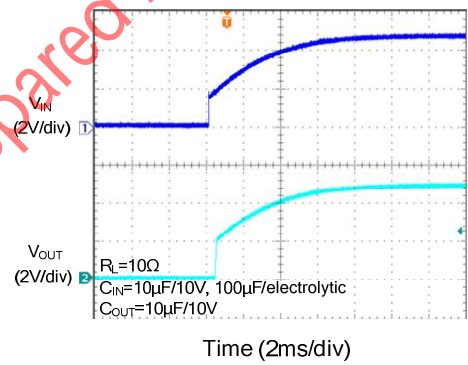

UVLO at Falling

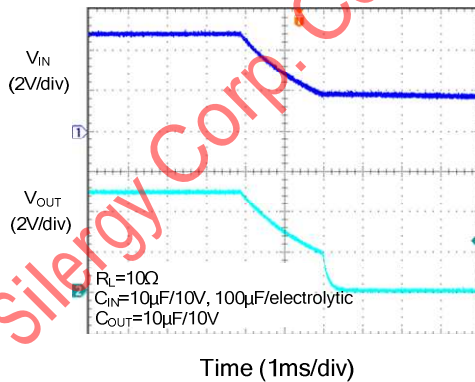

EN ON

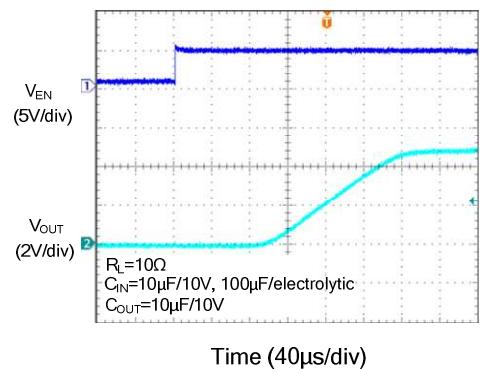



SY6280/SY6280A

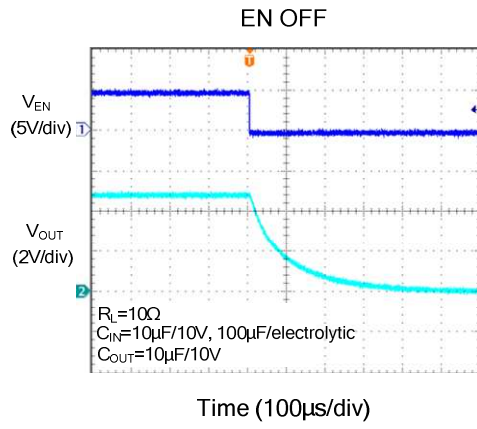

Silergy Corp. Confidential-Prepared for



SY6280/SY6280A

Operation

SY6280/A is a current limited P-channel MOSFET power switch with over current and over temperature protections. There is no body diode across the drain and the source of the MOSFET. It prevents the current flow from the output to the input after the chip is disabled.

Over-current protection

When the over-current condition is detected, the switch is regulated to achieve constant output current. If the over current condition lasts for a long time, and results in a junction temperature over 130°C, the switch will be shutdown. Once the junction temperature drops to 110°C, the part will restart.

Supply Filter Capacitor

In order to prevent the input voltage from dropping during hot-plug condition, a 10µF ceramic capacitor from VIN to GND is strongly recommended. However, higher capacitance could help reduce the voltage drop. Furthermore, an output short will cause ringing on the input without the input capacitor. It could destroy the internal circuitry when the input transient voltage exceeds the absolute maximum supply voltage even for a short duration.

Current Limiting Setting

Current limit is programmable to protect the power source from over current and short circuit conditions. Connect a resistor R_{SET} from ISET pin to GND to program the current limit:

$$I_{LIM} (A) = 6800 / R_{set} (\Omega)$$

The minimum current limit is 0.4A. Current limit beyond 2A is not recommended.

Maximum input voltage consideration:

For any application, input voltage for SY6280/A should not be allowed to exceed the maximum recommended value (5.5V).

Below is a typical application circuit for SY6280/A. The front stage is a non-synchronous boost stage and the input power supply can be a battery or an adapter.

Some adapters may have poor output voltage tolerance, or may have large output voltage overshoot if the adapter is not plug in directly. The voltage overshoot higher than VIN(5.5V) will significantly reduce the reliability of SY6280/A and may even lead to IC EOS failure.

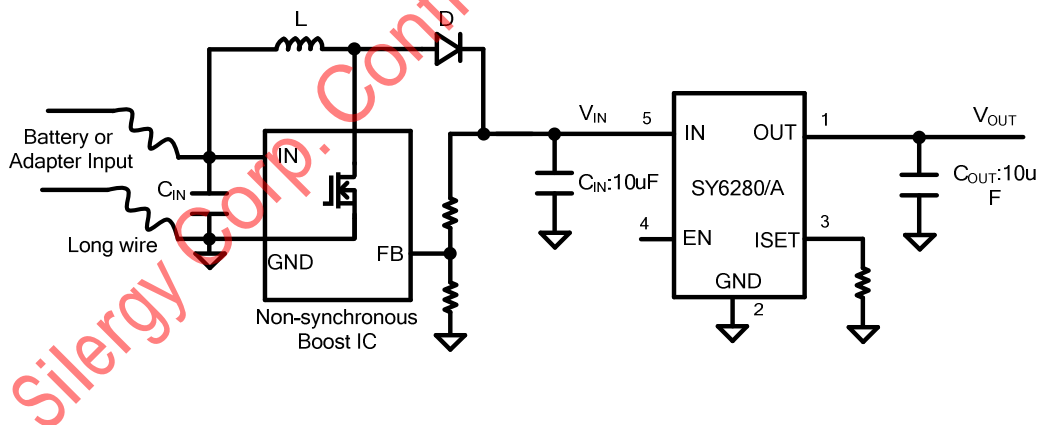



PCB Layout Guide

To achieve a better performance, the following guidelines must be strictly followed:

- Keep all power traces as short and wide as possible and use at least 2 ounce copper for all power traces.
- Place a ground plane under all circuitry to lower both resistance and inductance and improve DC and transient performance.
- Locate the output capacitors as close to the connectors as possible to lower the impedance (mainly inductance) between the port and the capacitor and improve transient performance.
- Input and output capacitors should be placed close to the IC and connected to the ground plane to reduce noise coupling.
- Locate the ceramic bypass capacitors as close as possible to the IN pin and OUT pin of SY6280/A.

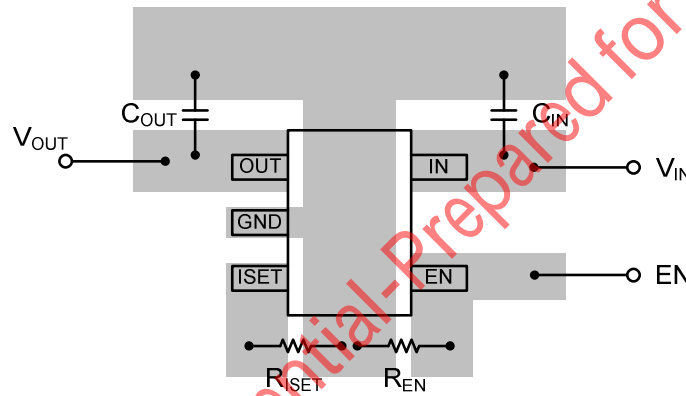

Top View: PCB Layout Guide(SOT23-5)

SOT23-5 Package outline & PCB layout design

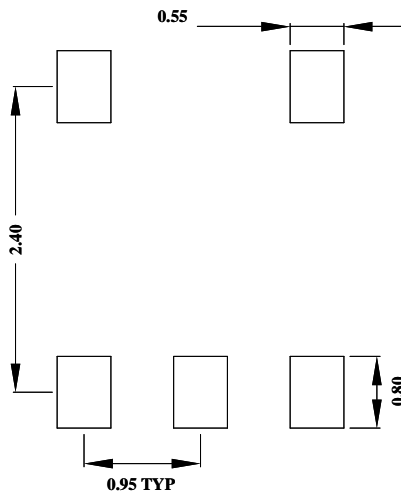

Recommended Pad Layout

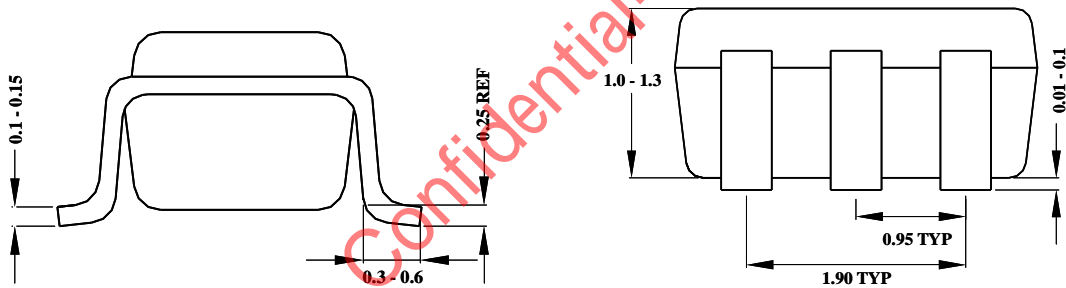
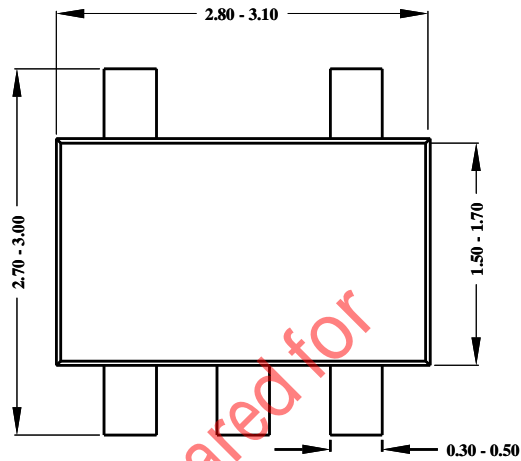

**Notes: All dimensions are in millimeters.
All dimensions don't include mold flash & metal burr.**

Taping & Reel Specification

1. Taping orientation

SOT23-5

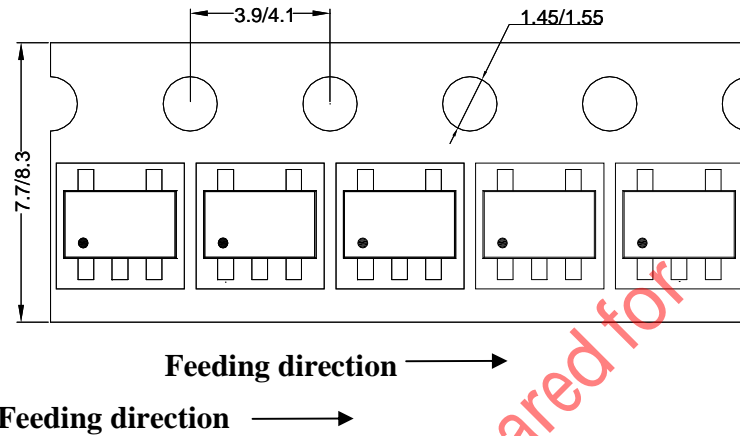

2. Carrier Tape & Reel specification for packages

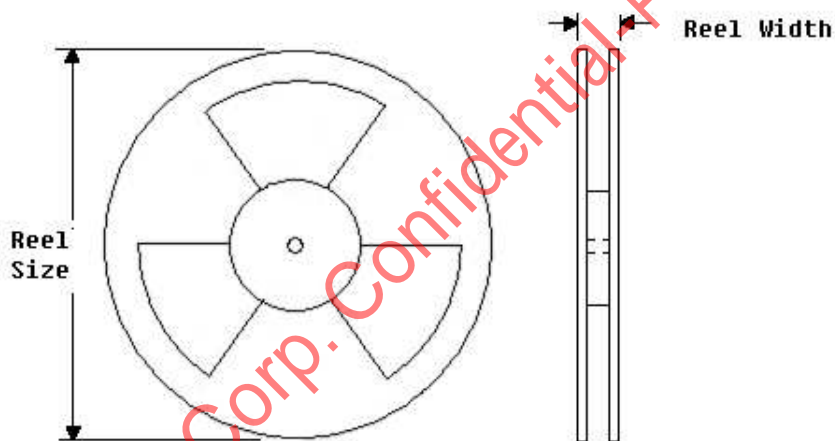

Package types	Tape width (mm)	Pocket pitch(mm)	Reel size (Inch)	Reel width(mm)	Trailer length(mm)	Leader length (mm)	Qty per reel
SOT23-5	8	4	7"	8.4	280	160	3000

3. Others: NA

X-ON Electronics

Largest Supplier of Electrical and Electronic Components

Click to view similar products for [Power Switch ICs - Power Distribution](#) category:

Click to view products by [Silergy](#) manufacturer:

Other Similar products are found below :

[NCP45520IMNTWG-L](#) [TCK111G,LF\(S](#) [FPF1018](#) [DS1222](#) [TCK2065G,LF](#) [SZNCP3712ASNT3G](#) [TLE7244SL](#) [MIC2033-05BYMT-T5](#)
[MIC2033-12AYMT-T5](#) [MIC2033-05BYM6-T5](#) [SLG5NT1437VTR](#) [SZNCP3712ASNT1G](#) [DML1008LDS-7](#) [KTS1640QGDV-TR](#)
[KTS1641QGDV-TR](#) [NCV459MNWTBG](#) [NCP4545IMNTWG-L](#) [NCV8412ASTT1G](#) [NCV8412ASTT3G](#) [BTT3018EJXUMA1](#)
[FPF2260ATMX](#) [SLG59M1557VTR](#) [BD2222G-GTR](#) [NCP45780IMN24RTWG](#) [NCP45540IMNTWG-L](#) [MC10XS6200EK](#) [MC10XS6225EK](#)
[MC25XS6300EK](#) [MC33882PEP](#) [MC10XS6325EK](#) [TPS2021IDRQ1](#) [TPS2103D](#) [TPS22954DQCR](#) [TPS22958NDGKR](#) [TPS22994RUKR](#)
[TPS2561AQDRCRQ1](#) [MIC2005-0.5YML-TR](#) [MIC2098-1YMT-TR](#) [MIC2098-2YMT-TR](#) [MIC94062YMT TR](#) [MIC94064YMT-TR](#)
[MP6231DN-LF](#) [MP62551DGT-LF-P](#) [BTS117](#) [BTS500151TADATMA2](#) [VN540SP-E](#) [MIC2015-1.2YM6 TR](#) [MIC2026-2YM](#) [MIC2075-2YM](#)
[MIC2095-2YMT-TR](#)