



Application Note: SY6283/SY6283A

Low Loss Power Distribution Load Switch 3A continuous, 4A peak current Advanced Design Specification

General Description

SY6283 and SY6283A are ultra-low $R_{DS(ON)}$ switch with current limiting function to protect the power source from over current and short circuit conditions.

Ordering Information

SY6283 □(□)□□
 □ Temperature Code
 □ Package Code
 □ Optional Spec Code

Temperature Range: -40°C to 85°C

Ordering Number	Package type	Note
SY6283DRC	DFN1.2×1.6-4	3A/Active High
SY6283ADRC	DFN1.2×1.6-4	3A/Active High

Features

- Distribution voltages: 2.5V to 5.5V
- Over temperature shutdown and automatic retry
- Reverse blocking (no body diode)
- At shutdown, OUT can be forced higher than IN
- Built-in softstart
- Output discharge function
 - ✧ SY6283: No output discharge function
 - ✧ SY6283A: Auto output discharge function
- RoHS Compliant and Halogen Free
- Compact packages minimize board space: DFN1.2x1.6-4

Typical Application Circuit

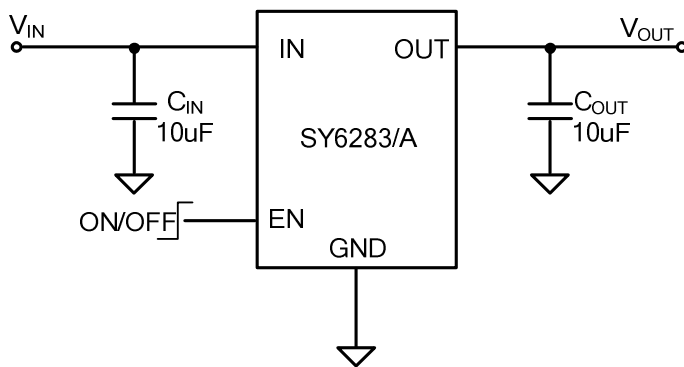

Figure 1. Schematic Diagram

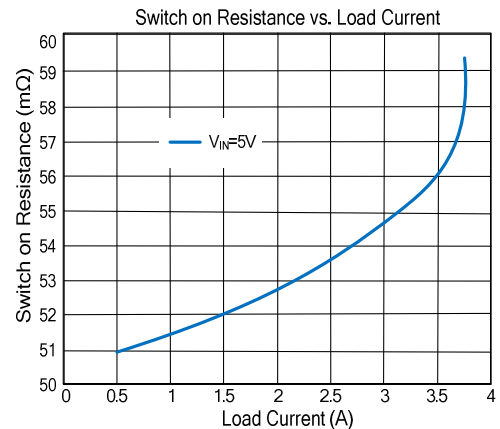
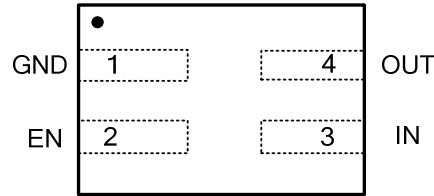

Figure 2. Typical Perform Characteristic



Pin Configurations (Top View)



DFN1.2×1.6-4

Top mark: LPxyz for SY6283(Device code: LP, *x*=year code, *y*=week code, *z*=lot number code)

MWxyz for SY6283A(Device code: MW, *x*=year code, *y*=week code, *z*=lot number code)

Functional Pin Description

Pin Name	Pin number	Pin Description
IN	3	Input pin. Decouple this pin to GND with 4.7uF input Capacitor.
GND	1	Ground pin.
OUT	4	Output pin.
EN	2	ON/OFF control. Do not leave it float.

Absolute Maximum Ratings (Note 1)

All pins-----	6V
Power Dissipation, Pd @ TA = 25°C DFN1.2×1.6-4-----	0.5W
Package Thermal Resistance (Note 2)	
θJA -----	200°C/W
θJC -----	70°C/W
Junction Temperature Range -----	-40°C to 125°C
Lead Temperature (Soldering, 10 sec.) -----	260°C
Storage Temperature Range -----	-65°C to 150°C

Recommended Operating Conditions (Note 3)

IN-----	2.5V to 5.5V
EN-----	-0.3V to VIN+0.3V
All other pins -----	0-5.5V
Junction Temperature Range -----	-40°C to 125°C
Ambient Temperature Range -----	-40°C to 85°C



Electrical Characteristics

($V_{IN} = 5V$, $C_L = 1\mu F$, per channel, $T_A = 25^\circ C$ unless otherwise specified)

Parameter	Symbol	Test Conditions	Min	Typ	Max	Unit
Input Voltage Range	V_{IN}		2.5		5.5	V
Shutdown Input Current	I_{SHDN}	Output grounded, switch off		0.1	1	μA
Quiescent Supply Current	I_Q	Open load, switch on		32		μA
FET RON	$R_{DS(ON)}$			60		m Ω
Current Limit	I_{LIM}		3.0	3.85	4.7	A
EN Threshold	V_{IH}		2			V
IN UVLO Threshold	$V_{IN,UVLO}$				2.4	V
IN UVLO Hysteresis	$V_{IN,HYS}$			0.1		V
Rising Time	t_{Rising}	$R_L = 5\ \Omega$, $C_L = 1\mu F$		0.75		ms
Thermal Shutdown Temperature	T_{SD}			150		$^\circ C$
Thermal Shutdown Hysteresis				20		$^\circ C$
Output Discharge Resistor	R_{DSC}	SY6283A		10		Ω

Note 1: Stresses beyond “Absolute Maximum Ratings” may cause permanent damage to the device. These are for stress ratings. Functional operation of the device at these or any other conditions beyond those indicated in the operational sections of the specifications is not implied. Exposure to absolute maximum rating conditions for extended periods may affect device reliability.

Note 2: θ_{JA} is measured in the natural convection at $T_A = 25^\circ C$ on a low effective single layer thermal conductivity test board of JEDEC 51-3 thermal measurement standard.

Note 3: The device is not guaranteed to function outside its operating conditions



Typical Operating Characteristics

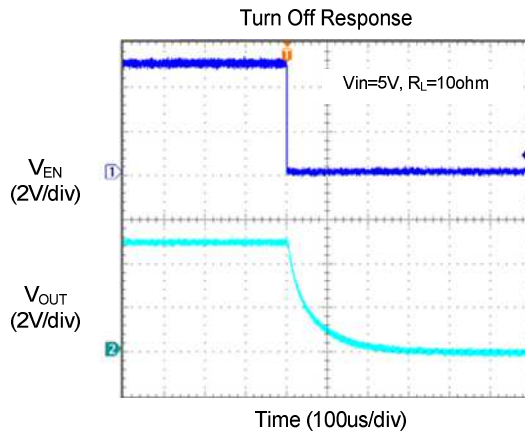
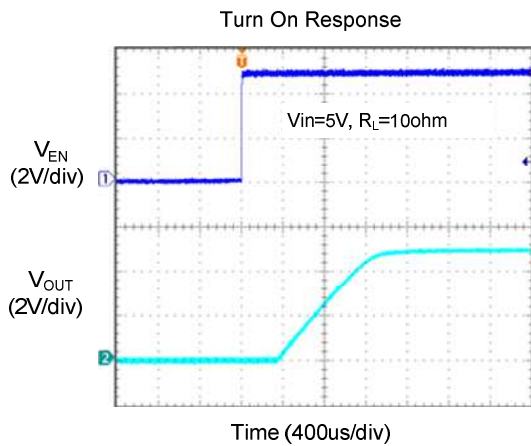
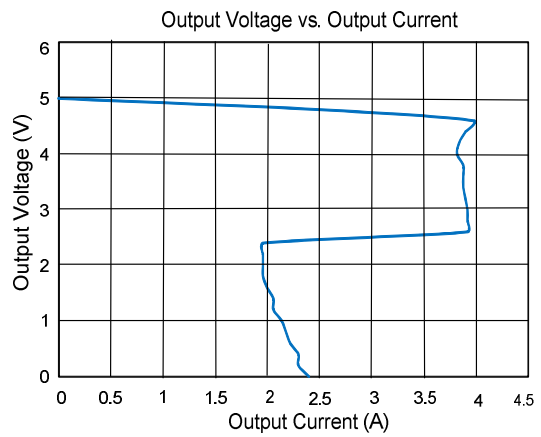
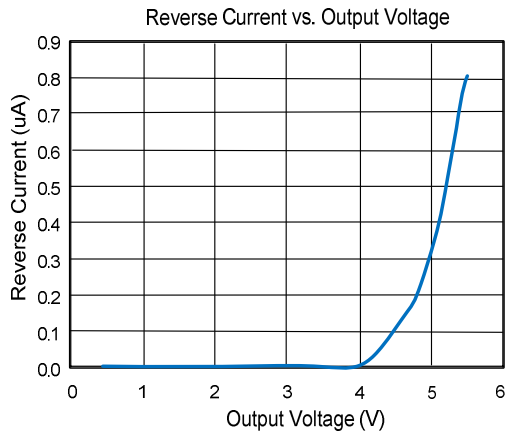
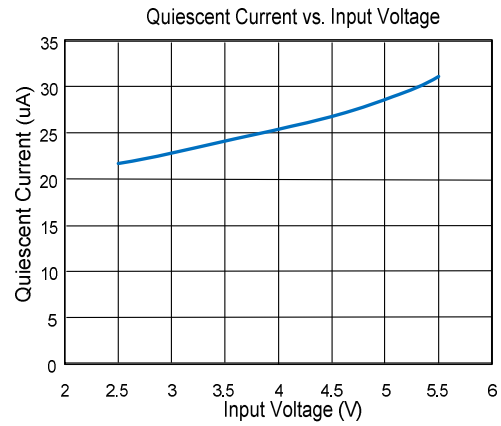
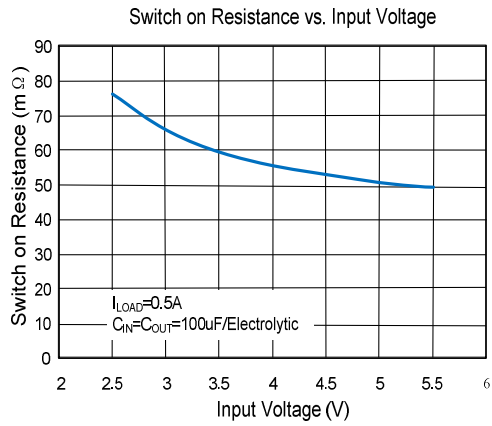



AN_SY6283/SY6283A

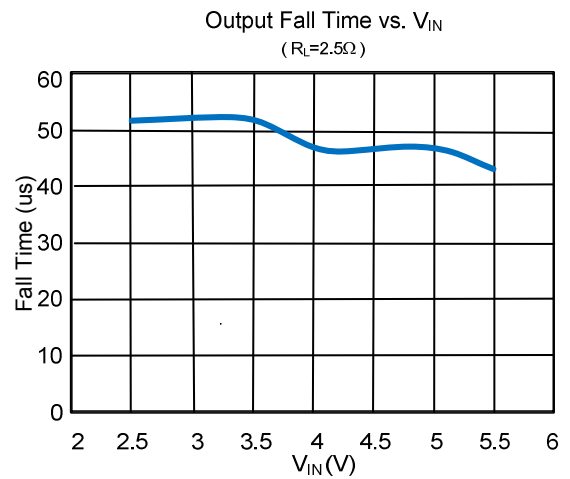
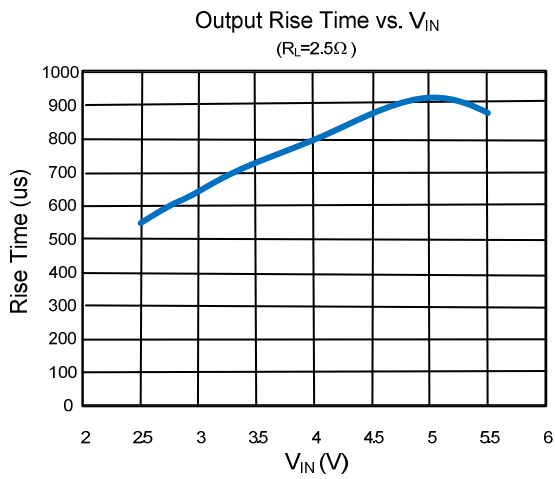
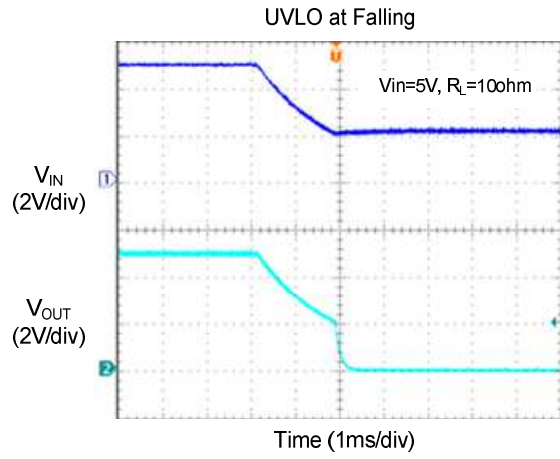
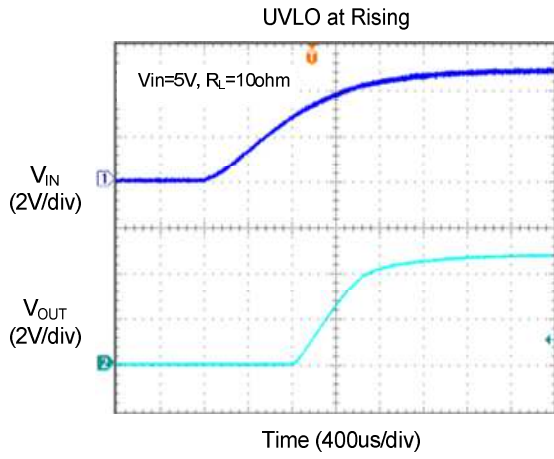

Block diagram

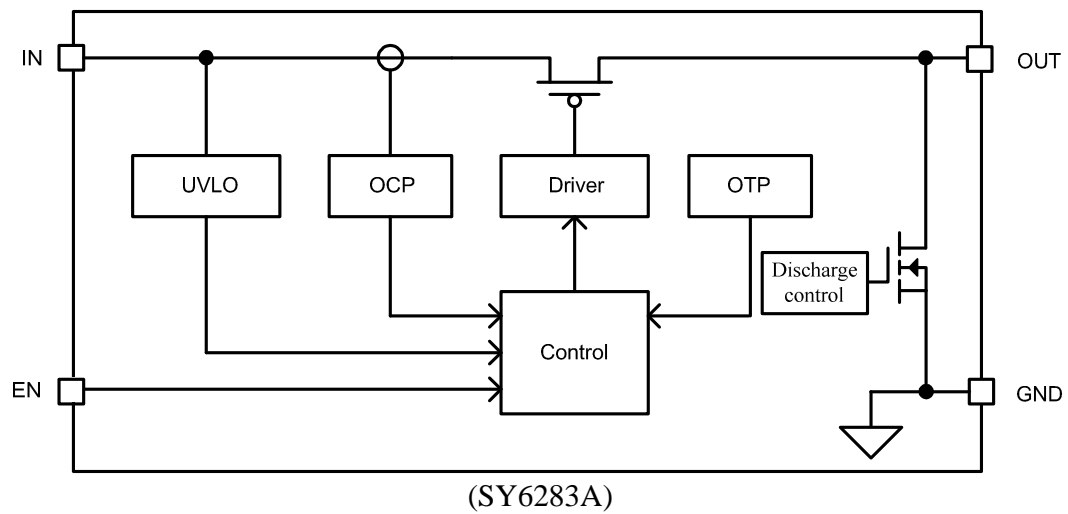
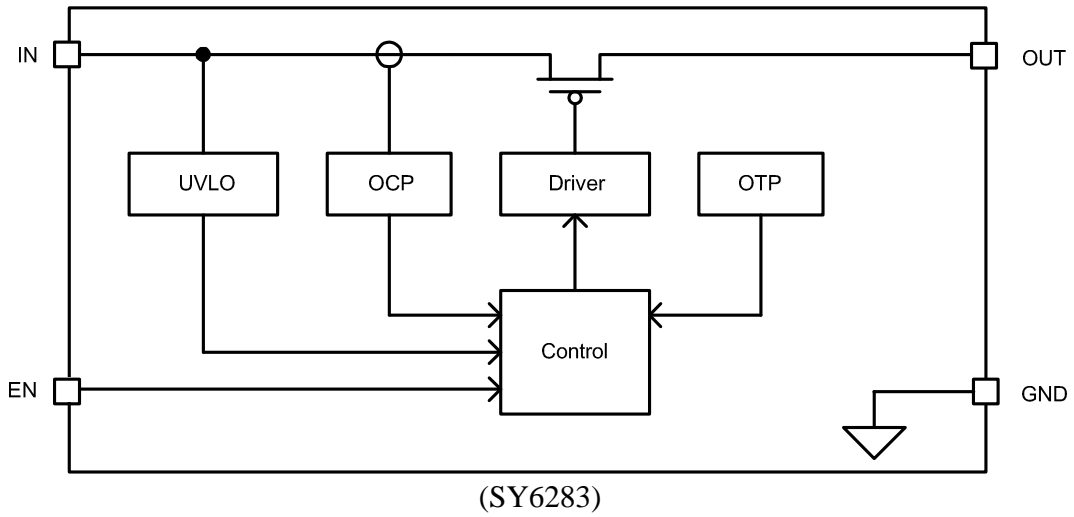



Operation

SY6283 is a current limited P-channel MOSFET power switch with over current and over temperature protections. There is no body diode across the drain and the source of the MOSFET. It prevents the current flow from the output to the input after the chip is disabled.

Over-current protection

When the over-current condition is detected, the switch is regulated to achieve constant output current. If the over current condition lasts for a long time, and results in a junction temperature over 150°C, the switch will be shutdown. Once the junction temperature drops to 130°C, the part will restart.

PCB Layout Guide

For best performance of the SY6283 , the following guidelines must be strictly followed:

- Keep all V_{BUS} traces as short and wide as possible and use at least 2 ounce copper for all V_{BUS} traces.
- Place a ground plane under all circuitry to lower both resistance and inductance and improve DC and transient performance.
- A low-ESR 150uF aluminum electrolytic or tantalum capacitor between VOUT and GND is strongly recommended.
- Locate the output capacitor as close to the connectors as possible to lower impedance(mainly inductance) between the port and the capacitor and improve transient performance.
- Input and output capacitors should be placed closed to the IC and connected to ground plane to reduce noise coupling.
- Locate the ceramic bypass capacitors as close as possible to the VIN pins and VOUT pins of SY6283.

Supply Filter Capacitor

In order to prevent the input voltage from dropping during hot-plug condition, a 10 μ F ceramic capacitor from VIN to GND is strongly recommended. However, higher capacitance could help to reduce the voltage drop. Furthermore, an output short will cause ringing on the input without the input capacitor. It could destroy the internal circuitry when the input transient voltage exceeds the absolute maximum supply voltage even for a short duration.

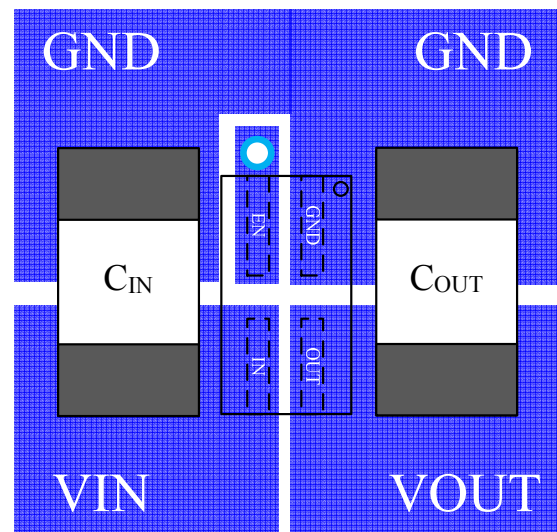



PCB Layout Guide

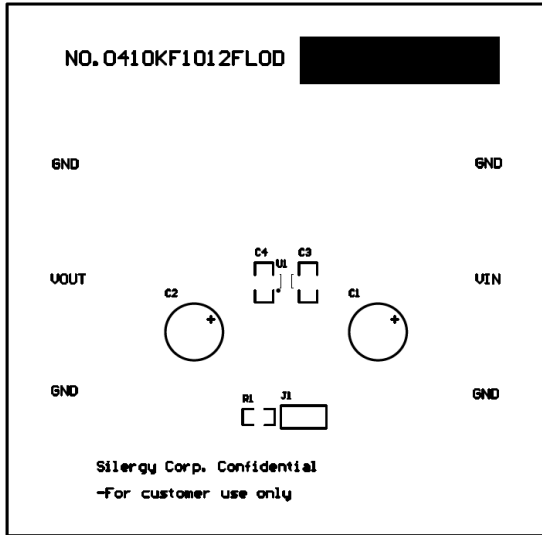

PCB Top Over Layer

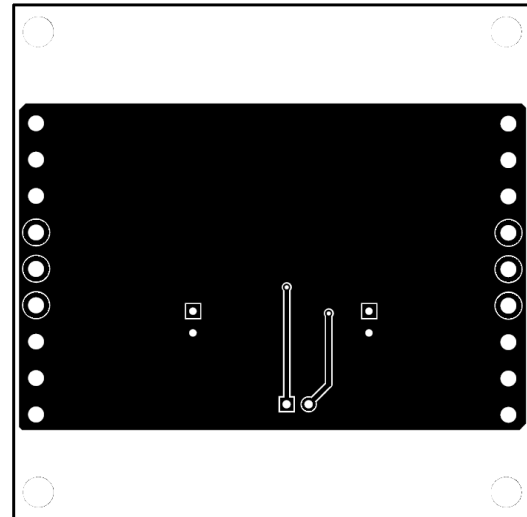

PCB Bottom Layer

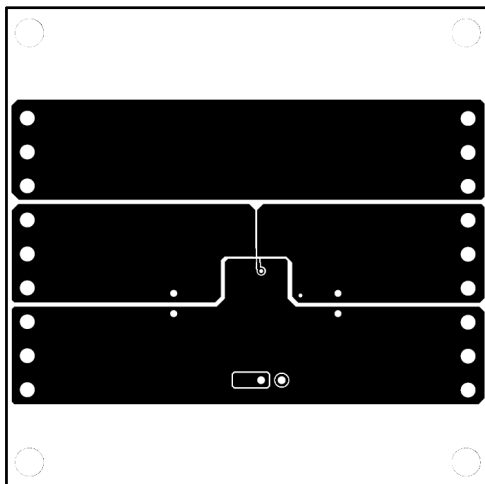

PCB Top Layer

DFN1.2x1.6-4L FC Package Outline

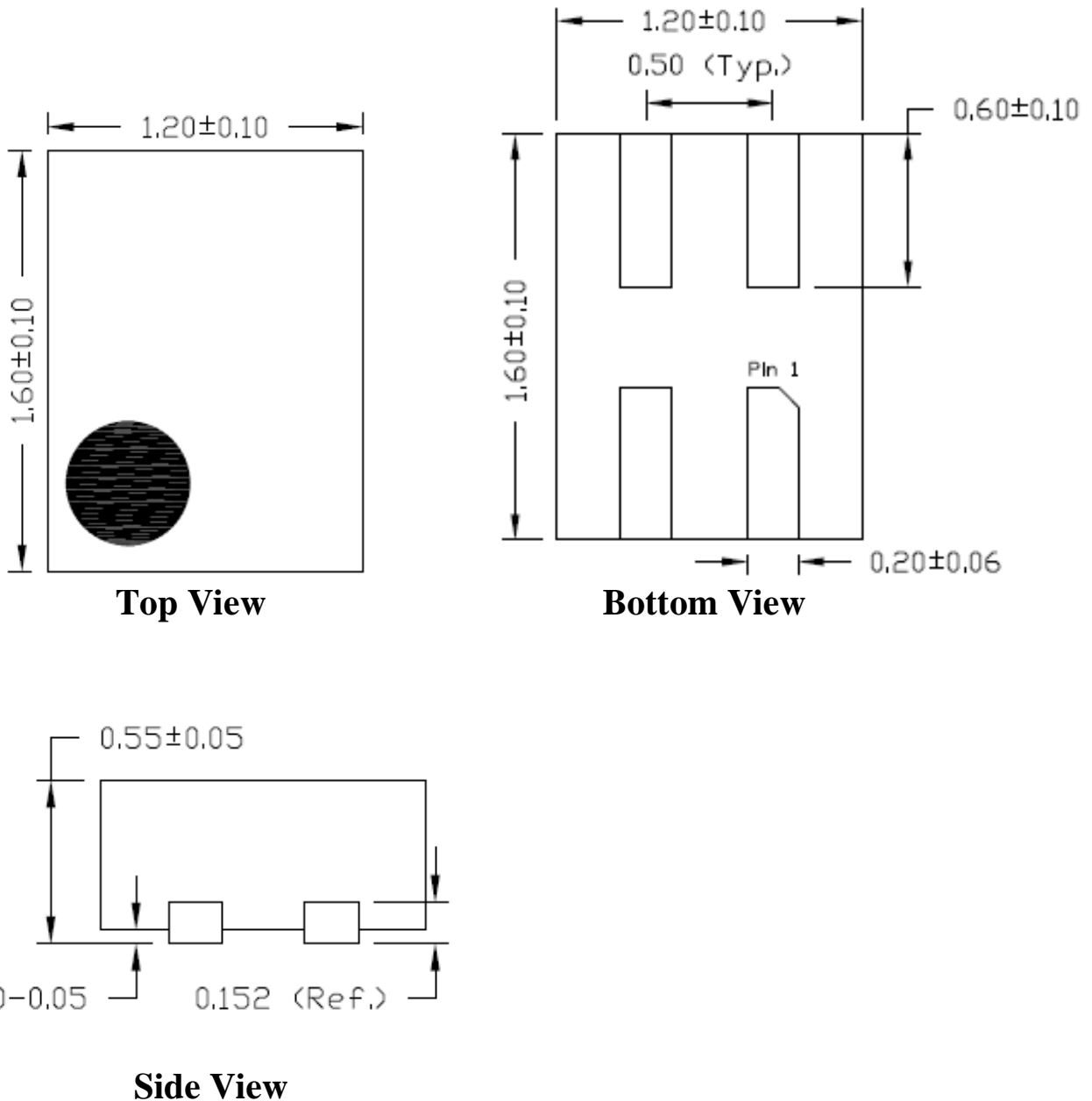

Notes: All dimension in MM and exclude mold flash & metal burr.

Taping & Reel Specification

1. DFN3x3-10 taping orientation

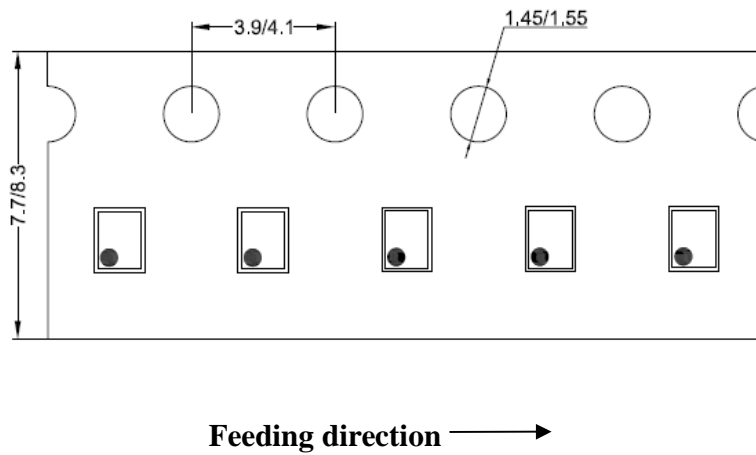

2. Carrier Tape & Reel specification for packages

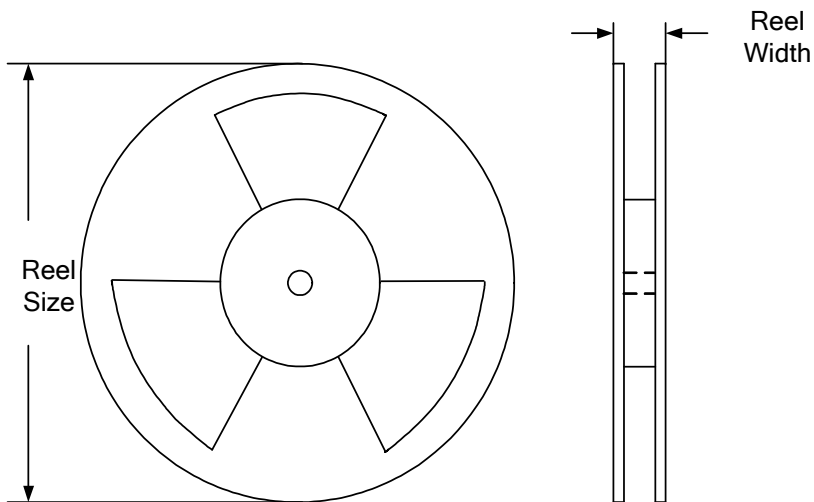

Package types	Tape width (mm)	Pocket pitch(mm)	Reel size (Inch)	Reel width(mm)	Trailer length(mm)	Leader length (mm)	Qty per reel
DFN1.2x1.6	8	4	7"	8.4	400	160	3000

3. Others: NA

X-ON Electronics

Largest Supplier of Electrical and Electronic Components

Click to view similar products for [Power Switch ICs - Power Distribution](#) category:

Click to view products by [Silergy](#) manufacturer:

Other Similar products are found below :

[NCP45520IMNTWG-L](#) [TCK111G,LF\(S](#) [FPF1018](#) [DS1222](#) [TCK2065G,LF](#) [SZNCP3712ASNT3G](#) [TLE7244SL](#) [MIC2033-05BYMT-T5](#)
[MIC2033-12AYMT-T5](#) [MIC2033-05BYM6-T5](#) [SLG5NT1437VTR](#) [SZNCP3712ASNT1G](#) [DML1008LDS-7](#) [KTS1640QGDV-TR](#)
[KTS1641QGDV-TR](#) [NCV459MNWTBG](#) [NCP4545IMNTWG-L](#) [NCV8412ASTT1G](#) [NCV8412ASTT3G](#) [BTT3018EJXUMA1](#)
[FPF2260ATMX](#) [SLG59M1557VTR](#) [BD2222G-GTR](#) [NCP45780IMN24RTWG](#) [NCP45540IMNTWG-L](#) [MC10XS6200EK](#) [MC10XS6225EK](#)
[MC25XS6300EK](#) [MC33882PEP](#) [MC10XS6325EK](#) [TPS2021IDRQ1](#) [TPS2103D](#) [TPS22954DQCR](#) [TPS22958NDGKR](#) [TPS22994RUKR](#)
[TPS2561AQDRCRQ1](#) [MIC2005-0.5YML-TR](#) [MIC2098-1YMT-TR](#) [MIC2098-2YMT-TR](#) [MIC94062YMT TR](#) [MIC94064YMT-TR](#)
[MP6231DN-LF](#) [MP62551DGT-LF-P](#) [BTS117](#) [BTS500151TADATMA2](#) [VN540SP-E](#) [MIC2015-1.2YM6 TR](#) [MIC2026-2YM](#) [MIC2075-2YM](#)
[MIC2095-2YMT-TR](#)