



SILERGY

Application Note: AN_SY6912A

2A Multi-Cell High Efficiency Switching Charger

General Description

SY6912A is a 4.0-23V input, 2A multi-cell synchronous Buck Li-Ion battery charger, suitable for portable application. Select pin is convenient for multi-cell charging. 800 kHz synchronous buck regulator integrates of 25V rating FETs with ultra low on- resistance to achieve high efficiency and simple circuit design.

Ordering Information

SY6912 □(□□)□

- └─ Temperature Code
- └─ Package Code
- └─ Optional Spec Code

Ordering Number	Package type	Note
SY6912AFCC	SO8E	

Features

- Wide Input Voltage Range: 4.0V to 23V
- High Efficiency Int. Synchronous Buck Regulator with Fixed 800kHz Switching Frequency
- Selectable for Multi-cell Charging
- Trickle Current / Constant Current / Constant Voltage Charging Mode
- Programmable (2A Max) Constant Charging Current
- Programmable Charging Timer
- Input Voltage UVLO and Battery OVP
- Over Temperature Protection
- Output Short Circuit Protection
- Automatic Shutdown Prevents Reverse Energy Flow
- Charging Status Indication
- Normal Synchronous Buck Operation when Battery Removed
- Compact package SO8E

Applications

- Cellular Telephones,
- PDA, MP3 Players, MP4 Players
- Digital Cameras
- Bluetooth Applications
- PSP Game Players, NDS Game Players
- Notebook

Typical Applications

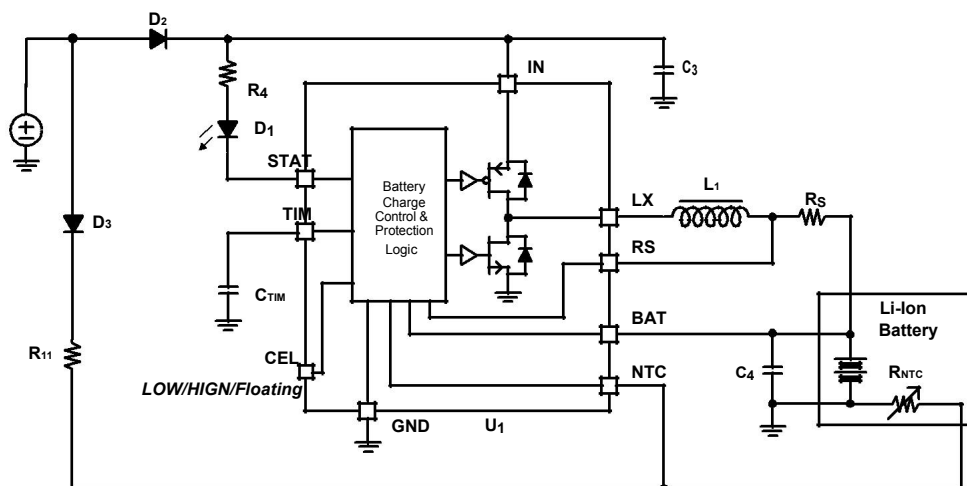
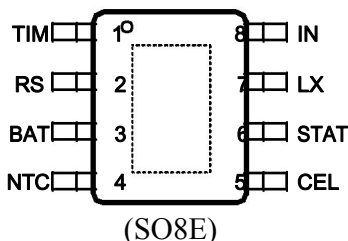

Figure 1. SY6912A Schematic Diagram



Pinout (top view)



Top Mark: AIQxyz (device code: AIQ, x=year code, y=week code, z=lot number code)

Name	Number	Description
RS	2	Charging current program pin. Connect a current sense resistor from RS pin to BAT pin. Average charging current is detected for both TC mode and CC mode.
BAT	3	Battery positive pin.
NTC	4	Thermal protection pin. UTP threshold is about 75%V _{IN} and OTP threshold is about 30%V _{IN} . Pull up to V _{IN} can disable charging logic and make the IC operate as normal buck regulator. Pull down to ground can shutdown the IC.
CEL	5	Pull down for single-cell, pull high for 2 cells, open for 3 cells.
STAT	6	Charging status indication pin. It is open drain output pin and can be used to turn on a LED to indicate the charging in process. When the charging is done, LED is off.
LX	7	Switch node pin. This pin connects the drains of the integrated main and synchronous power MOSFET switches. Connect to external inductor.
IN	8	Positive power supply input pin. V _{IN} ranges from 4V to 23V for normal operation. It has UVLO function and must be 120mV greater than the battery voltage to enable normal operation.
TIM	1	Charging time limit pin. Connect this pin with a capacitor to ground. Internal current source charges the capacitor for TC mode and CC mode's charging time limit. TC charging time limit is about 1/9 of CC charging time.
GND	Exposed pad	Ground pin.

Absolute Maximum Ratings (Note 1)

CEL, NTC, STAT	-0.5-32V
IN, BAT, LX	-0.5-25V
TIM	-0.5- 3.6V
RS	BAT-0.3~BAT+0.3V
LX Pin current continuous	2.5A
Power Dissipation, P _D @ T _A = 25° , SO8E	3.3W
Package Thermal Resistance (Note 2)	
θ _{JA}	30°C/W
θ _{JC}	20°C/W
Junction Temperature Range	-40°C to 150°C
Lead Temperature (Soldering, 10 sec.)	260°C
Storage Temperature Range	-65°C to 125°C
ESD Susceptibility (Note 2)	
HBM (Human Body Mode)	2kV
MM (Machine Mode)	200V

Recommended Operating Conditions (Note 3)

CEL, NTC, STAT	-0.3-30V
IN, BAT, LX	-0.3-23V
TIM	- 0.3- 3.6V
RS	BAT-0.1~BAT+0.1V
LX Pin current continuous	2A



AN_SY6912A

Junction Temperature Range ----- -20°C to 125°C
Ambient Temperature Range ----- -40°C to 85°C



Electrical Characteristics

T_A=25°C, V_{IN}=15V, GND=0V, C_{IN}=10uF, L_B=2.2uH, R_S=25mΩ, C_{TIM}=330nF, unless otherwise specified.

Symbol	Parameter	Conditions	Min	Typ	Max	Unit
Bias Supply (V_{IN})						
V _{IN}	Supply voltage		4.0		23	V
V _{UVLO}	V _{IN} under voltage lockout threshold	V _{IN} rising and measured from V _{IN} to GND			3.9	V
ΔV _{UVLO}	V _{IN} under voltage lockout hysteresis	Measured from V _{IN} to GND		190		mV
V _{OV}	Input overvoltage protection	V _{IN} rising and measured from V _{IN} to GND			24	V
ΔV _{OV}	Input overvoltage protection hysteresis	Measured from V _{IN} to GND		750		mV
Quiescent Current						
I _{BAT}	Battery discharge current	NTC pull down to GND			25	uA
I _{IN}	Input quiescent current	Disable Charging			2.0	mA
Oscillator and PWM						
f _{OSC}	Oscillator frequency		640	800	960	kHz
D	PFET duty cycle				100	%
Power MOSFET						
R _{NFET}	R _{DS(ON)} of N-FET			150		mΩ
R _{PFET}	R _{DS(ON)} of P-FET			160		mΩ
Voltage Regulation						
V _{CV}	Single-cell CV charging mode	0°C ≤ T _A ≤ 70°C	4.16	4.20	4.24	V
	2-cell CV charging mode		8.32	8.40	8.48	
	3-cell CV charging mode		12.48	12.60	12.72	
ΔV _{RCH}	Single-cell Voltage threshold for Recharge	0°C ≤ T _A ≤ 70°C	50	100	150	mV
	2-cell Voltage threshold for Recharge		100	200	300	
	3-cell Voltage threshold for Recharge		150	300	450	
V _{TRK}	Single-cell TC charging mode voltage threshold	0°C ≤ T _A ≤ 70°C	2.2	2.5	2.8	V
	2-cell TC charging mode voltage threshold		4.4	5.0	5.6	
	3-cell TC charging mode voltage threshold		6.6	7.5	8.4	
Battery Connect Detection						
V _{DET}	NTC voltage threshold for Battery detect	NTC Falling Edge	80%		90%	V _{IN}
t _{DET}	Detect delay time			30		ms
Charging Current						
	Internal charging current accuracy for Constant Current Mode	I _{CC} =25mV/R _S	-10%		10%	
	Internal charging current accuracy for Trickle Current Mode	I _{TC} =2.5mV/R _S	-50%		50%	
Output Voltage OVP						
V _{OV}	Output voltage OVP threshold		108%	113%	118%	V _{CV}
Output Short Protection						
V _{SHOT}	Output short protection threshold	V _{BAT} falling edge	1.70	2.00	2.30	V
f _{FBK}	Frequency fold back	V _{BAT} <2V		12.5%		f _{OSC}
I _{LM}	Power FET current limit			4.0		A
Timer						
T _{TC}	Trickle current charging timeout	C _{TIM} =330nF	0.425	0.5	0.575	hour
T _{CC}	Constant current charging timeout		3.825	4.5	5.175	hour
T _{MC}	Charging mode change delay time			30		ms
T _{TERM}	Termination delay time			30		ms
T _{RCHG}	Recharge time delay			30		ms
Battery Thermal Protection NTC						
UTP	Under temperature protection		70%	75%	80%	V _{IN}
	Under temperature protection hysteresis	Falling edge		5%		
OTP	Over temperature protection		28%	30%	32%	
	Over temperature protection hysteresis	Rising edge		2%		
Automatic Shutdown						
ΔV _{ASD}	ASD voltage threshold hysteresis	Measured from V _{IN} to V _{BAT}		80	240	mV
Thermal shutdown						
TSD	Thermal shutdown temperature	Rising Threshold		160		°C
TSDHYS	Thermal shutdown temperature hysteresis			20		°C



Note 1: Stresses beyond the “Absolute Maximum Ratings” may cause permanent damage to the device. These are stress ratings only. Functional operation of the device at these or any other conditions beyond those indicated in the operational sections of the specification is not implied. Exposure to absolute maximum rating conditions for extended periods may affect device reliability.

Note 2: θ_{JA} is measured in the natural convection at $T_A = 25^\circ\text{C}$ on a low effective four-layer thermal conductivity test board of JEDEC 51-3 thermal measurement standard.

Note 3: The device is not guaranteed to function outside its operating conditions

Basic Li-Ion Battery Charge Operation Flow Chart

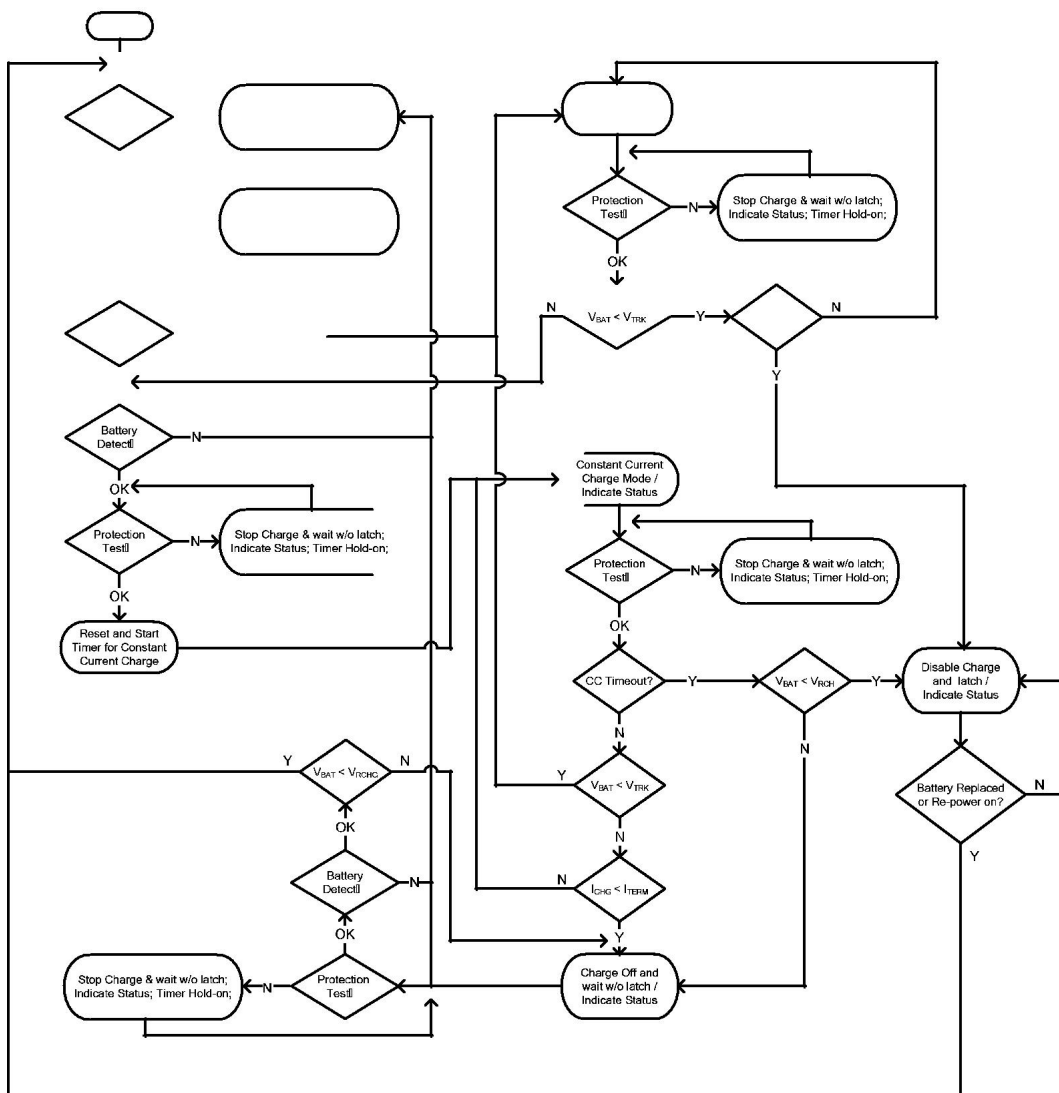



General Function Description

SY6912A is a 4.0-23 input, 2A multi-cell synchronous buck Li-Ion battery charger, suitable for portable application. Select pin is convenient for multi-cell charging. Integrated 800kHz synchronous buck regulator consists of 25V rating FETs with extremely low on-resistance to achieve high charging efficiency and simple circuit design.

Charging Status Indication Description

1. **Charging-In-Process** – Pull and keep STAT pin to Low;
2. **Charging Done** – Pull and keep STAT pin to High;
3. **Fault Mode** – Output high and low voltage alternatively with 0.5Hz frequency when C_{TIM} is 330nF.

Connect a LED from VIN to STAT pin, **LED ON** indicates **Charging-in-Process**, **LED OFF** indicates **Charging Done**, **LED Flash** indicates **Fault Mode**.

Buck Regulator Operation Description

If the Li-Ion battery is removed suddenly, the voltage on NTC pin increases higher than 90% V_{in} . Then, it operates as a normal peak current mode controlled synchronous buck converter and the output voltage on BAT pin is regulated at V_{CV} . In this operation mode, the constant output current loop is still active, however the charging timeout operation, termination function and the trickle current charging are disabled.

Protection Description

Thermal Protection-Thermal shutdown is active for both battery and IC. IC resumes normal work when the temperature backs in normal range again.

Short Circuit Protection- When V_{BAT} voltage is lower than the short circuit protection threshold, short circuit protection is active. In charger operation mode, the switching frequency is folded back to 12.5% of the default value and V_C is folded back to 20% of the maximum value. The trickle charging timer is still active and would timeout the IC finally. In Buck operation mode, the switching frequency is folded back to 12.5% of the default value, and the V_C initiates softstart periodically.

Over Current Protection-The internal current loop with different constant current capability is always active no matter in Buck mode or Battery Charging mode for the over current protection.

Over Voltage Protection-When V_{BAT} voltage is higher than the over voltage protection threshold no matter with or without battery connected, IC shuts down and recovers to normal work when V_{BAT} backs to normal level. Input voltage has UVLO and OVP, which would make IC shutdown and recover to normal work when the V_{IN} backs to normal range.

Timeout Protection-Programmable timeout protection is for both Trickle Current Charging Mode and Constant Current Charging Mode. Once timeout is active, IC stops the charging operation and latches off. Only power or battery re-plug in can get the latch logic reset and the IC restarted.



Typical Performance Characteristics

$T_A=25^{\circ}\text{C}$, $V_{IN}=5\text{V}$, $R_S=12.5\text{m}\Omega$, 1cell battery, unless otherwise specified.

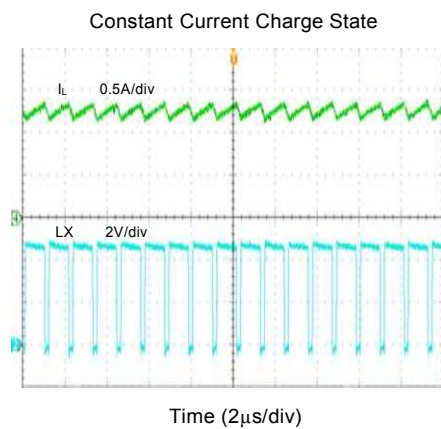
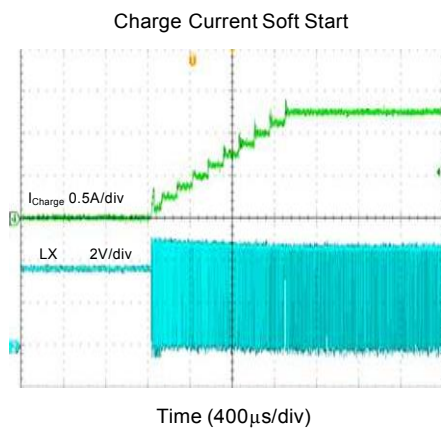
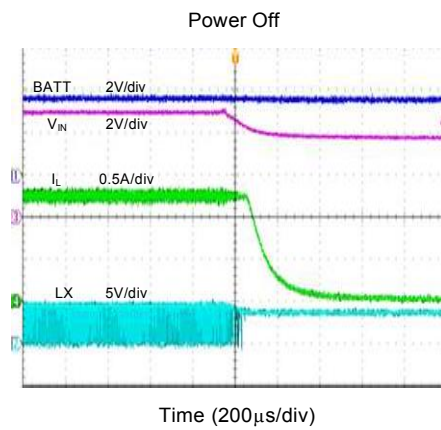
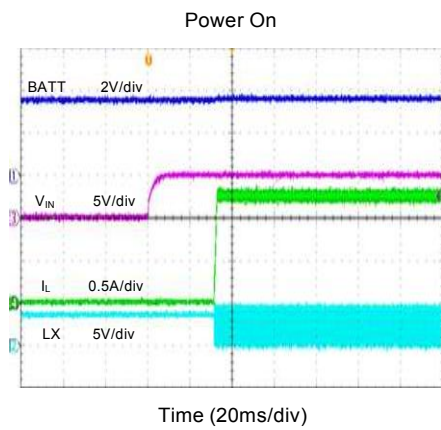
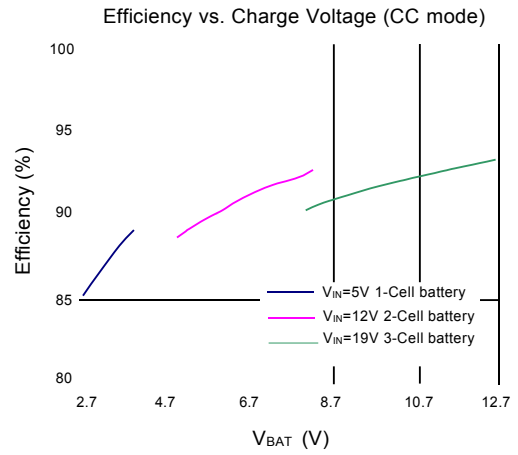
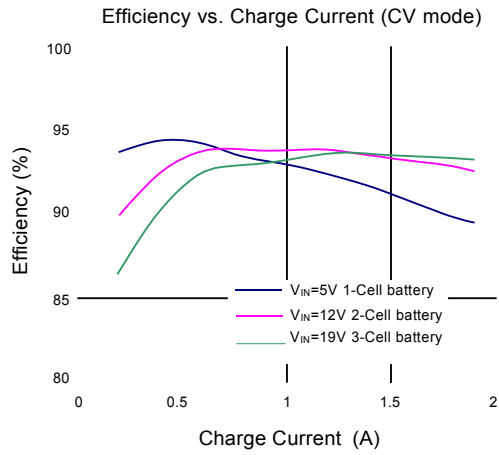

Battery Short

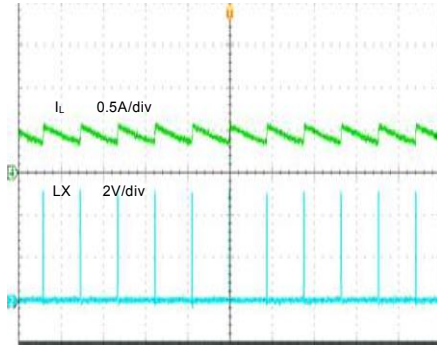

Time (10 μ s/div)

Buck Mode: Output Short

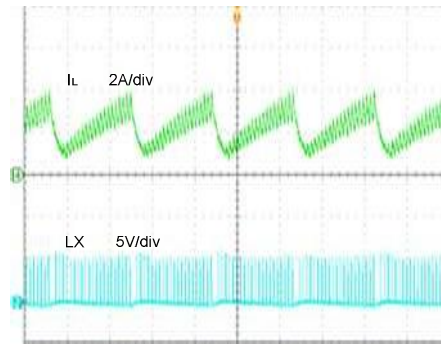

Time (100 μ s/div)



Applications Information

Because of the high integration of SY6912A, the application circuit based on this regulator IC is rather simple. Only input capacitor C_{IN}, output capacitor C_{OUT}, inductor L, NTC resistors R1, R2, charging current sense resistor R_s and timer capacitor C_{TIM} need to be selected for the targeted applications specifications.

NTC resistor:

SY6912A monitors battery temperature by measuring the input voltage and NTC voltage. The controller triggers the UTP or OTP when the ratio K (K= V_{NTC}/V_{IN}) reaches the threshold of UTP (K_{UT}) or OTP (K_{OT}). The temperature sensing network is showed as below.

Choose R1 and R2 to program the proper UTP and OTP points.

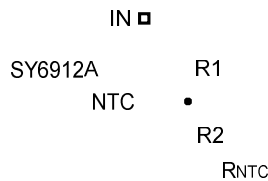

The calculation steps are:

1. Define K_{UT}, K_{UT}=70~80%
2. Define K_{OT}, K_{OT}=28~32%
3. Assume the resistance of the battery NTC thermistor is R_{UT} at UTP threshold and R_{OT} at OTP threshold.
4. Calculate R2,

$$R2 = \frac{K_{OT}(1 - K_{UT})R_{UT} - K_{UT}(1 - K_{OT})R_{OT}}{K_{UT} - K_{OT}}$$

5. Calculate R1

$$R1 = (1 / K_{OT} - 1) (R2 + R_{OT})$$

If choose the typical values K_{UT}=75% and K_{OT}=30%, then

$$R2 = 0.17R_{UT} - 1.17R_{OT}$$

$$R1 = 2.3(R2 + R_{OT})$$

Charging current sense resistor R_s

The charging current sense resistor R_s is calculated as below:

$$R_s = \frac{25}{I_{CC}}, \quad \text{Unit: mohm}$$

While the I_{CC} is the battery constant charging current, unit is ampere.

Timer capacitor C_{TIM}

The charger also provides a programmable charging timer. The charging time is programmed by the capacitor connected between the TIM pin and GND. The capacitance is given by the formula:

$$C_{TIM} = 2 * 10^{-11} T_{CC} \quad \text{Unit: F}$$

T_{CC} is the target charging time, unit is second.

Input capacitor C_{IN}:

The ripple current through input capacitor is greater than

$$I_{CIN_MIN} = I_{CC} \sqrt{D(1-D)}$$

To minimize the potential noise problem, place a typical X7R or better grade ceramic capacitor really close to the IN and GND pins. Care should be taken to minimize the loop area formed by C_{IN}, and IN/GND pins.

Output capacitor C_{OUT}:

The output capacitor is selected to handle the output ripple noise requirements. Both steady state ripple and transient requirements must be taken into consideration when selecting this capacitor. For the best performance,

it is recommended to use X7R or better grade ceramic capacitor with 10uF capacitance.

Output inductor L:

There are several considerations in choosing this inductor.

- 1) Choose the inductance to provide the desired ripple current. It is suggested to choose the ripple current to be about 40% of the average input current.

The inductance is calculated as:

$$L = \frac{V_{OUT}(1 - V_{OUT}/V_{IN,MAX})}{F_{SW} \times I_{OUT,MAX} \times 40\%}$$

Where F_{SW} is the switching frequency and I_{OUT,MAX} is the maximum load current.

SY6912A is quite tolerant of different ripple current amplitude. Consequently, the final choice of inductance can be slightly off the calculation value without significantly impacting the performance.

- 2) The saturation current rating of the inductor must be selected to be greater than the peak inductor current under full load conditions.

$$I_{SAT, MIN} > I_{OUT, MAX} + \frac{V_{OUT}(1 + V_{OUT}/V_{IN, MAX})}{2 \times F_{SW} \times L}$$

- 3) The DCR of the inductor and the core loss at the switching frequency must be low enough to achieve the desired efficiency requirement. It is desirable to choose an inductor with $DCR < 10\text{mohm}$ to achieve a good overall efficiency.

Layout Design:

The layout design of SY6912A regulator is relatively simple. For the best efficiency and minimum noise problems, we should place the following components close to the IC: C_{IN} , L.

- 1) It is desirable to maximize the PCB copper area connecting to GND pin to achieve the best thermal and

noise performance. If the board space allowed, a ground plane is highly desirable.

- 2) C_{IN} must be close to Pins IN and GND. The loop area formed by C_{IN} and GND must be minimized. Following picture is the recommended layout design of C_{IN} .

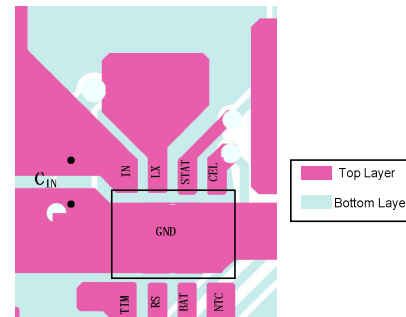

- 3) The PCB copper area associated with LX pin must be minimized to avoid the potential noise problem.

- 4) The capacitor C_{TIM} and the trace connecting to the TIM pin must not be adjacent to the LX net on the PCB layout to avoid the noise problem. It should be better to ground C_{TIM} to the output capacitor's ground.

SO8E Package outline & PCB layout design

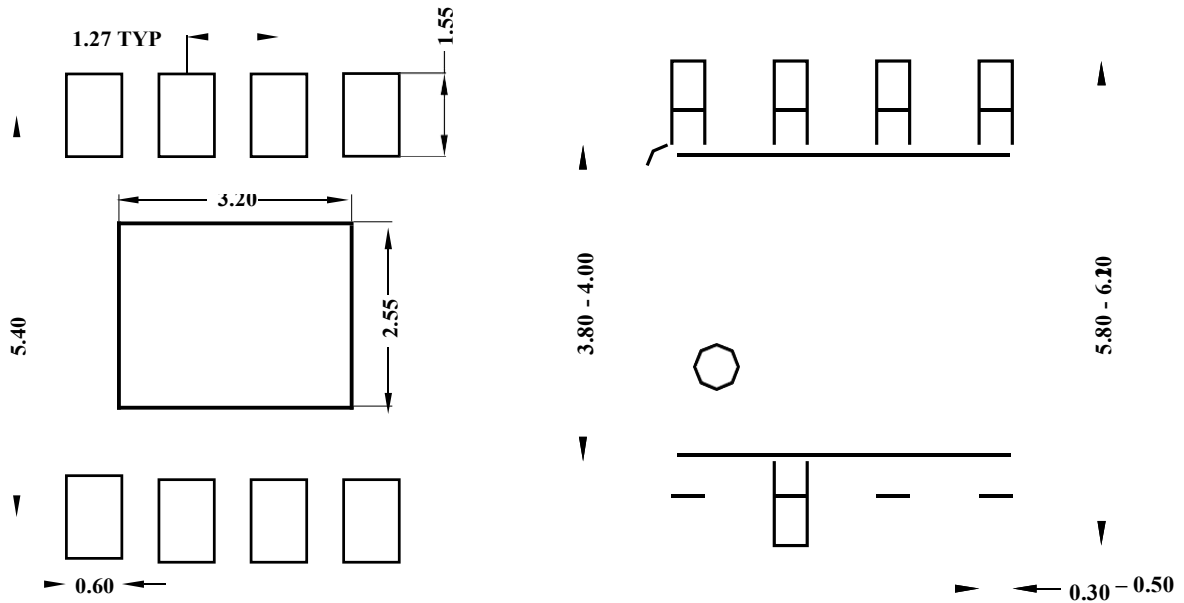

Recommended Pad Layout

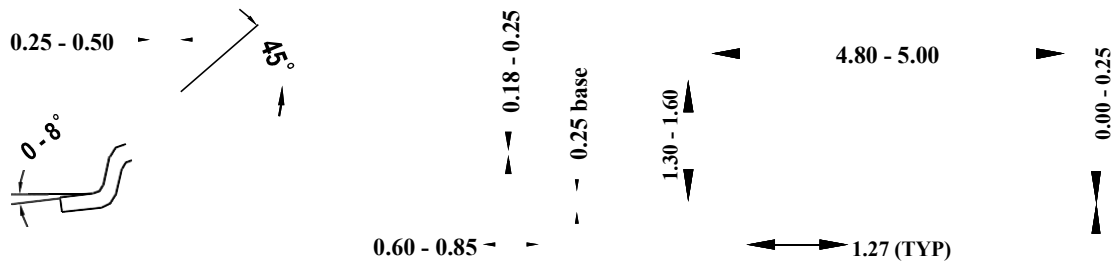

**Notes: All dimensions are in millimeters.
All dimensions don't include mold flash & metal burr.**

Taping & Reel Specification

1. Taping orientation

SO8E

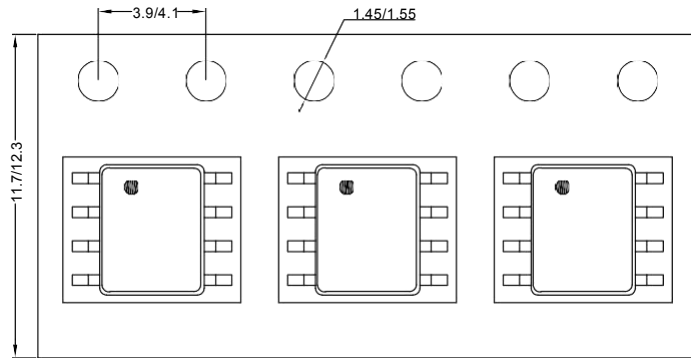

Feeding direction →

2. Carrier Tape & Reel specification for packages

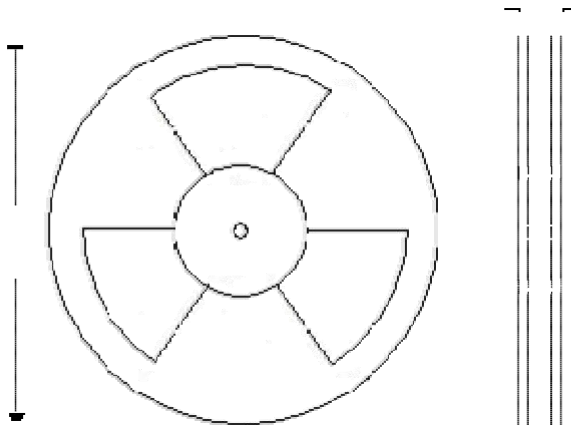

Package types	Tape width (mm)	Pocket pitch(mm)	Reel size (Inch)	Reel width(mm)	Trailer length(mm)	Leader length (mm)	Qty per reel
SO8E	12	8	13"	12.4	400	400	2500

3. Others: NA

X-ON Electronics

Largest Supplier of Electrical and Electronic Components

Click to view similar products for [Battery Management](#) category:

Click to view products by [Silergy](#) manufacturer:

Other Similar products are found below :

[VN5R003HTR-E](#) [NCP1855FCCT1G](#) [FAN54063UCX](#) [NCP367DPMUEBTBG](#) [LC05132C01NMTTTG](#) [ISL78714ANZ](#) [CM1104-EH](#)
[CM1104-DBB](#) [CM1104-MBB](#) [XC6801A421MR-G](#) [ISL95521BHRZ](#) [ISL95521BIRZ](#) [MP2639AGR-P](#) [S-82D1AAE-A8T2U7](#) [S-82D1AAA-](#)
[A8T2U7](#) [S-8224ABA-I8T1U](#) [MC33772CTA1AE](#) [MC33772CTC0AE](#) [BQ28Z610DRZR-R1](#) [MCP73832-4ADI/MC](#) [MCP73832T-2DCIMC](#)
[MCP73833T-AMIMF](#) [MCP73833T-AMI/UN](#) [MCP73838-NVI/MF](#) [MCP73213-A6BI/MF](#) [MCP73831-2ACI/MC](#) [MCP73831T-2ATIMC](#)
[MCP73832-2ACI/MC](#) [MCP73832T-3ACIMC](#) [MCP73833T-FCI/MF](#) [MCP73853-IML](#) [BQ25895RTWR](#) [BQ29704DSER](#) [BQ78Z100DRZR](#)
[ISL78610ANZ](#) [FAN5403UCX](#) [NCP367DPMUECTBG](#) [FAN54015BUCX](#) [MAX8934BETI+](#) [BQ24311DSGR](#) [BQ25100HYFPR](#)
[BQ29707DSER](#) [MAX17048G+T10](#) [BQ24130RHRLR](#) [BQ25120AYFPR](#) [BQ29703DSER](#) [BQ771807DPJR](#) [BQ25120AYFPT](#)
[MAX17055ETB+T](#) [MAX17710GB+T](#)