



# Application Note: AN\_SY7311A/B/D

## 40V High Current Boost LED Driver

### General Description

SY7311A, SY7311B and SY7311D are step-up DC/DC converters that deliver an accurate constant current for driving LEDs. Operating at a fixed switching frequency of 1MHz allows the device to be used with small value external ceramic capacitors and inductor. LEDs connected in series are driven with a regulated current set by the external resistor. The SY7311A, SY7311B and SY7311D are ideal for driving up to ten white LEDs in series or up to 40V.

### Ordering Information

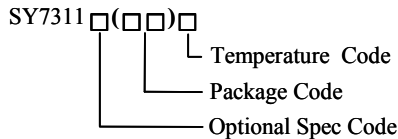

Ordering Number	Package	Dimming Frequency
SY7311AADC	TSOT23-6	10kHz~1MHz
SY7311BADC	TSOT23-6	100Hz~10kHz
SY7311DADC	TSOT23-6	10kHz~1MHz
SY7311ADEC	DFN2×2-6	10kHz~1MHz
SY7311BDEC	DFN2×2-6	100Hz~10kHz
SY7311DDEC	DFN2×2-6	10kHz~1MHz

### Features

- Input voltage range: 2.5 to 5.5V
- Switch current limit: 1A
- Drives LED strings up to 40V
- 1MHz fixed frequency minimizes the external components
- Dimming frequency for EN/PWM pin:
  - SY7311A/SY7311D: 10kHz~1MHz
  - SY7311B: 100Hz~10kHz
- Internal softstart limits the inrush current
- Open LED over voltage protection
- RoHS Compliant and Halogen Free
- Compact package: TSOT23-6/ DFN2×2-6

### Applications

- GPS Navigation Systems
- Handheld Devices
- Portable Media Players

### Typical Applications

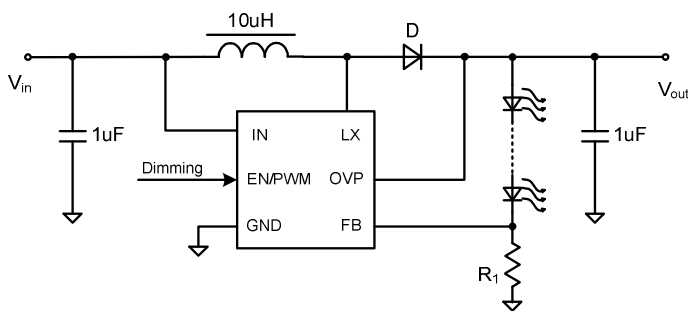

Figure 1. Schematic Diagram

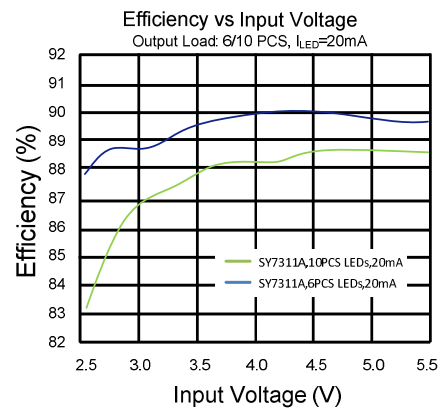
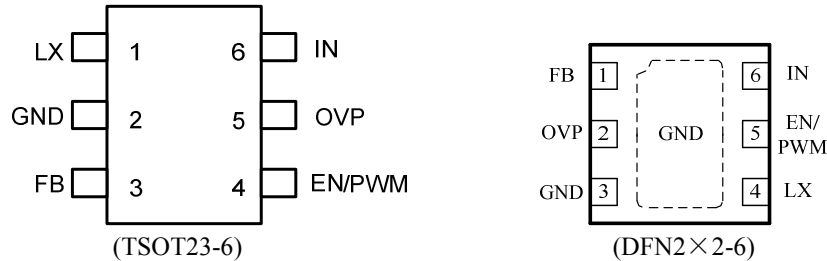

Figure 2. Efficiency Figure



# AN\_SY7311A/B/D

## Pinout (top view)



Ordering Number	Package	Dimming Frequency	Topmark
SY7311AADC	TSOT23-6	10kHz~1MHz	Ah xyz
SY7311BADC	TSOT23-6	100Hz~10kHz	Ai xyz
SY7311DADC	TSOT23-6	10kHz~1MHz	Aj xyz
SY7311ADEC	DFN2×2-6	10kHz~1MHz	YQxyz
SY7311BDEC	DFN2×2-6	100Hz~10kHz	YRxyz
SY7311DDEC	DFN2×2-6	10kHz~1MHz	Amxyz

Pin Name	Pin Number	Pin Description
LX	1	Inductor node. Connect an inductor between IN pin and LX pin.
GND	2	Ground pin.
FB	3	Feedback pin. Connect a resistor R1 between FB and GND to program the output current: SY7311A/SY7311B: $I_{OUT}=0.2V/R_1$ . SY7311D: $I_{OUT}=0.3V/R_1$ .
EN/PWM	4	SY7311A/SY7311D: Enable and dimming control. When used as enable input, pull high to turn on IC. And the recommend dimming frequency range is 10kHz~1MHz. SY7311B: Enable and dimming control. When used as enable input, pull high to turn on IC. And the recommend dimming frequency range is 100Hz~10kHz.
OVP	5	Over voltage protection.
IN	6	Input pin. Decouple this pin to GND pin with ceramic capacitor.

### Absolute Maximum Ratings (Note 1)

LX, OVP	-----	-0.3V to 40V
IN	-----	6V
EN/PWM, FB	-----	5.5V
Power Dissipation, $P_d$ @ $T_A = 25^\circ\text{C}$ , TSOT23-6/ DFN2×2-6	-----	0.55/0.7W
Package Thermal Resistance (Note 2)		
TSOT23-6/ DFN2×2-6, $\theta_{JA}$	-----	227/178°C/W
TSOT23-6/ DFN2×2-6, $\theta_{JC}$	-----	130/70°C/W
Junction Temperature Range	-----	150°C
Lead Temperature (Soldering, 10 sec.)	-----	260°C
Storage Temperature Range	-----	-65°C to 150°C

### Recommended Operating Conditions (Note 3)

LX, OVP	-----	-0.3V to 38V
Input Voltage Supply	-----	2.5V to 5.5V
Junction Temperature Range	-----	-40°C to 125°C
Ambient Temperature Range	-----	-40°C to 85°C



## Electrical Characteristics

( $V_{IN} = 3.6V$ ,  $T_A = 25^{\circ}C$ , unless otherwise specified)

Parameter	Symbol	Conditions	Min	Typ	Max	Unit
Input Voltage Range	$V_{IN}$		2.5		5.5	V
Quiescent Current	$I_Q$	$V_{FB}=0.3V(SY7311A,B)$ $V_{FB}=0.4V(SY7311D)$		50		$\mu A$
Shutdown Current	$I_{SHDN}$	EN=0		1		$\mu A$
Feedback Reference Voltage	$V_{REF}$	SY7311A, B SY7311D	196 294	200 300	204 306	mV
Feedback Reference Voltage (PWM linear dimming)	$V_{REF}$	For SY7311A PWM Duty cycle=5%	4	10	16	mV
		For SY7311D PWM Duty cycle=5%	6	15	24	
FB Input Current	$I_{FB}$	$V_{FB}=0.3V(SY7311A,B)$ $V_{FB}=0.4V(SY7311D)$	-50		50	nA
Low Side Main FET RON	$R_{DS(ON)}$			400		$m\Omega$
Main FET Current Limit	$I_{LIM}$	Main FET Duty cycle=90%		1		A
EN Rising Threshold	$V_{ENH}$		1.5			V
EN Falling Threshold	$V_{ENL}$				0.4	V
Input UVLO Threshold	$V_{UVLO}$				2.5	V
UVLO Hysteresis	$V_{HYS}$			0.2		V
Oscillator Frequency	$F_{OSC}$	$I_{OUT}=20mA$	0.8	1.0	1.2	MHz
Min On Time				80		ns
Max Duty Cycle			90	93		%
Thermal Shutdown	$T_{SD}$			150		$^{\circ}C$
Thermal Hysteresis	$T_{HYST}$			20		$^{\circ}C$
OVP Threshold	$V_{OVP}$		37			V
PWM dimming frequency		SY7311A, SY7311D	10k		1M	Hz
		SY7311B	100		10k	

**Note 1:** Stresses beyond the “Absolute Maximum Ratings” may cause permanent damage to the device. These are stress ratings only. Functional operation of the device at these or any other conditions beyond those indicated in the operational sections of the specification is not implied. Exposure to absolute maximum rating conditions for extended periods may affect device reliability.

**Note 2:**  $\theta_{JA}$  is measured in the natural convection at  $T_A = 25^{\circ}C$  on a low effective single layer thermal conductivity test board of JEDEC 51-3 thermal measurement standard. Test condition: Device mounted on 2” x 2” FR-4 substrate PCB, 2oz copper, with minimum recommended pad on top layer and thermal vias to bottom layer ground plane.

**Note 3:** The device is not guaranteed to function outside its operating conditions.



Block Diagram

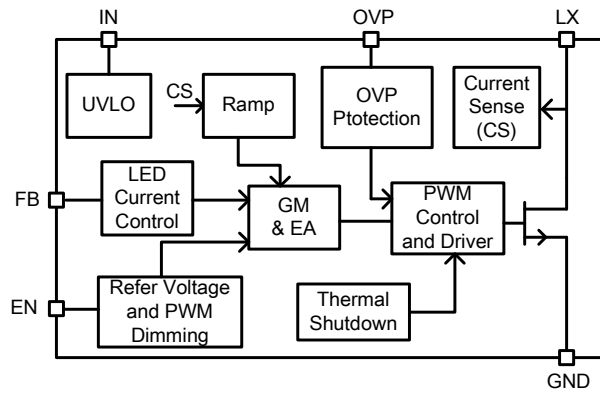



## Typical Performance Characteristics

( $V_{IN}=4.2V$ ,  $I_{LED}=20mA$ , 10 PCS LED Series( $V_{OUT}=30V$ ))

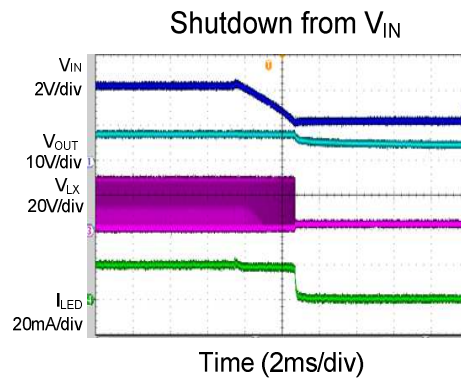
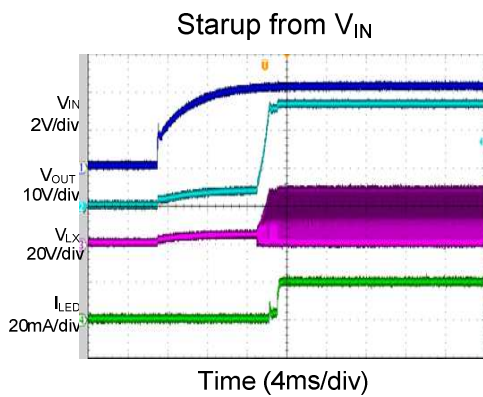
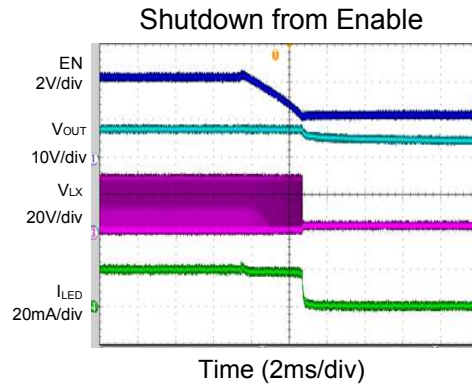
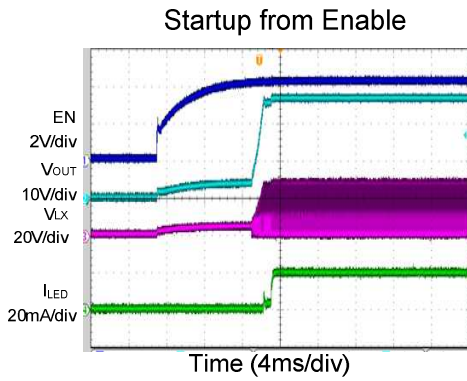
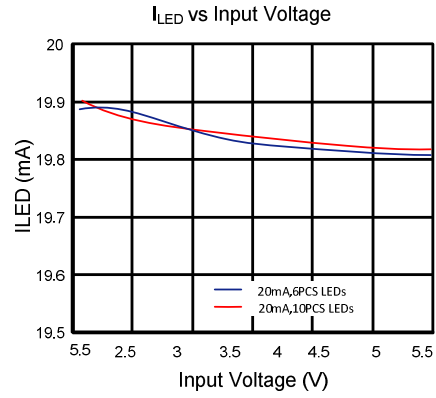
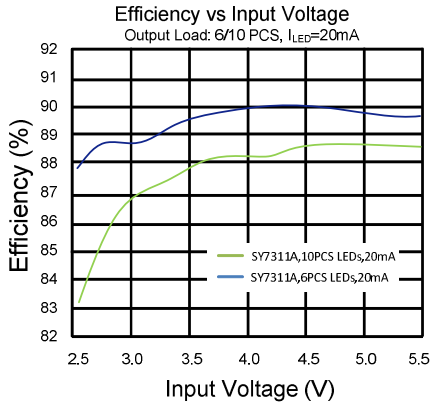

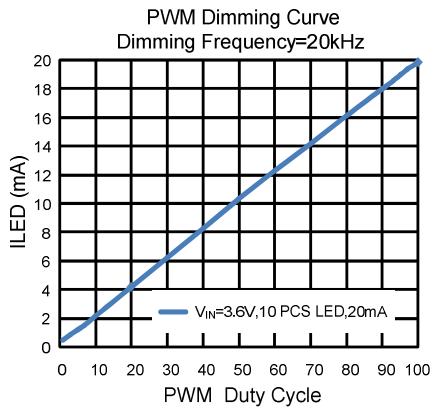



## Applications Information

SY7311 is a boost regulator IC that integrates the PWM control, power MOSFET on the same die to minimize the switching transition loss and conduction loss. With ultra low  $R_{DS(ON)}$  power switches and proprietary PWM control, this regulator IC can achieve the high efficiency and the high switch frequency simultaneously to minimize the external inductor and capacitor size, and thus achieving the minimum solution footprint.

Only input capacitor  $C_{IN}$ , output capacitor  $C_{OUT}$ , inductor L, Schottky diode D and sense resistors R1 need to be selected for the targeted applications specifications.

### Sense resistor R1 :

Choose R1 to program the proper LED Current. The R1 can be calculated to be:

$$R1 = \frac{V_{FB}}{I_{LED}}$$

$I_{LED}$  is the average LED current.

### Input capacitor CIN:

The ripple current through input capacitor is calculated as:

$$I_{CIN\_RMS} = \frac{V_{IN} \cdot (V_{OUT} - V_{IN})}{2\sqrt{3} \cdot L \cdot F_{SW} \cdot V_{OUT}}$$

An X5R or better grade ceramic capacitor with capacitance larger than 4.7uF is recommended to handle this ripple current. Place this ceramic capacitor really close to the IN and GND pins to minimize the potential noise problem. Care should be taken to minimize the loop area formed by CIN, and IN/GND pins.

### Output capacitor COUT:

The output capacitor is selected to handle the output ripple noise requirements. This ripple voltage is related to the capacitor's capacitance and its equivalent series resistance (ESR). For the best performance, it is recommended to use X5R or better grade low ESR ceramic capacitor. The voltage rating of the output capacitor should be higher than the maximum output voltage. The minimum required capacitance can be calculated as:

$$C_{OUT} = \frac{I_{OUT\_MAX} \cdot (V_{OUT} - V_{IN})}{F_{SW} \cdot V_{OUT} \cdot V_{RIPPLE}}$$

$V_{RIPPLE}$  is the peak to peak output ripple voltage.

For LED applications, the equivalent resistance of the LED is typically low. The output capacitance should be large enough to attenuate the ripple current through LED. A capacitor larger than 1uF is recommended.

### Inductor L:

There are several considerations in choosing this inductor.

- 1) Choose the inductance to provide the desired ripple current. It is suggested to choose the ripple current to be about 40% of the average input current. The inductance is calculated as:

$$L = \left( \frac{V_{IN}}{V_{OUT}} \right)^2 \frac{(V_{OUT} - V_{IN})}{F_{SW} \times I_{OUT\_MAX} \times 40\%}$$

where  $F_{SW}$  is the switching frequency and  $I_{OUT\_MAX}$  is the maximum load current.

The SY7311 regulator IC is quite tolerant of different ripple current amplitude. Consequently, the final choice of inductance can be slightly off the calculation value without significantly impacting the performance.

- 2) The saturation current rating of the inductor must be selected to be greater than the peak inductor current under full load conditions.

$$I_{SAT\_MIN} > \left( \frac{V_{OUT}}{V_{IN}} \right) \times I_{OUT\_MAX} + \left( \frac{V_{IN}}{V_{OUT}} \right)^2 \frac{(V_{OUT} - V_{IN})}{2 \times F_{SW} \times L}$$

- 3) The DCR of the inductor and the core loss at the switching frequency must be low enough to achieve the desired efficiency requirement. It is desirable to choose an inductor with  $DCR < 50\text{mohm}$  to achieve a good overall efficiency.

### Schottky Diode D:

Because of high switching speed of SY7311, a Schottky diode with low forward voltage drop and fast switching speed is desirable for the application. The voltage rating of the diode must be higher than maximum output voltage. The diode's average and peak current rating should exceed the average output current and peak inductor current.

### Dimming Control

SY7311 offer several different dimming schemes for LED brightness control. One way is to apply a PWM signal to the EN/PWM pin. Fig.3 shows the internal block diagram of the dimming circuit of SY7311A/D.

The PWM signal changes the regulation voltage by change the duty cycle. The relationship between the duty cycle and FB voltage is calculated as:

$$V_{FB} = \text{Duty} \times V_{FB}$$

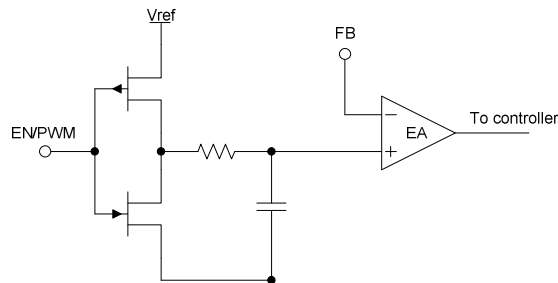

**Figure 3**

It is recommended selecting the PWM signal frequency to be higher than 10kHz.

Another way is to use a DC voltage as shown in Fig.4. The LED current decreases as the DC voltage rises. The relationship between LED current and DC voltage is:

$$I_{LED} = \frac{V_{FB} \times (R_1 + R_2) - V_{DC} \times R_1}{R_2 \times R_{FB}}$$

Where  $V_{FB}$  is the internal reference voltage,  $V_{DC}$  is the dimming DC voltage.

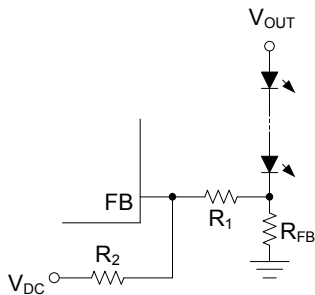
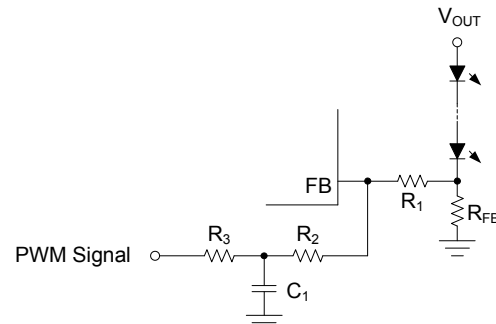

**Figure 4**

A filtered PWM signal can be used to substituted the DC input as shown in Fig.5. To better filter out the AC components of the PWM signal, it is recommend choosing the same value for  $R_2$  and  $R_3$  and the cut-off frequency of the low pass filter (formed by  $R_2/R_3$  and  $C_1$ ) to be well below the dimming signal frequency. The LED current decreases as the duty cycle increases. The LED current can be calculated using equation below:

$$I_{LED} = \frac{V_{FB} \times (R_1 + R_2 + R_3) - V_{PWM} \times \text{Duty} \times R_1}{(R_2 + R_3) \times R_{FB}}$$

Where  $V_{FB}$  is the internal reference voltage,  $V_{PWM}$  is the high voltage level of PWM signal, Duty is the duty cycle of PWM signal.



**Figure 5**

SY7311B adopts direct PWM dimming control as shown in Fig.6. The EN/PWM directly controls the driver of power MOSFET. The internal MOSFET turns off when EN/PWM signal is low. And the MOSFET resumes switching when EN/PWM signal is high.

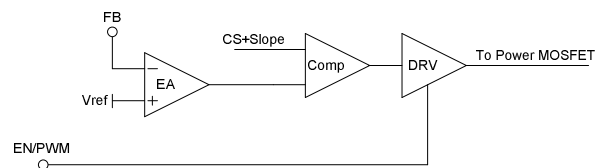

**Figure 6**

### Layout Design:

The layout design of SY7311 regulator is relatively simple. For the best efficiency and minimum noise problems, we should place the following components close to the IC:  $C_{IN}$ ,  $C_{OUT}$ , L, R1 and D.

- 1) It is desirable to maximize the PCB copper area connecting to GND pin to achieve the best thermal and noise performance. If the board space allowed, a ground plane is highly desirable.
- 2)  $C_{IN}$  must be close to Pins IN and GND. The loop area formed by  $C_{IN}$  and GND must be minimized.
- 3) Minimize the loop area of LX, D,  $C_{OUT}$  and GND.
- 4) The PCB copper area associated with LX pin must be minimized to avoid the potential noise problem.





5) The components R1, the trace connecting to the FB pin must NOT be adjacent to the LX net on the PCB layout to avoid the noise problem.

6) If the system chip interfacing with the EN pin has a high impedance state at shutdown mode and the IN pin

is connected directly to a power source such as a Li-Ion battery, it is desirable to add a pull down 1Mohm resistor between the EN and GND pins to prevent the noise from falsely turning on the regulator at shutdown mode.

## TSOT23-6 Package outline & PCB layout

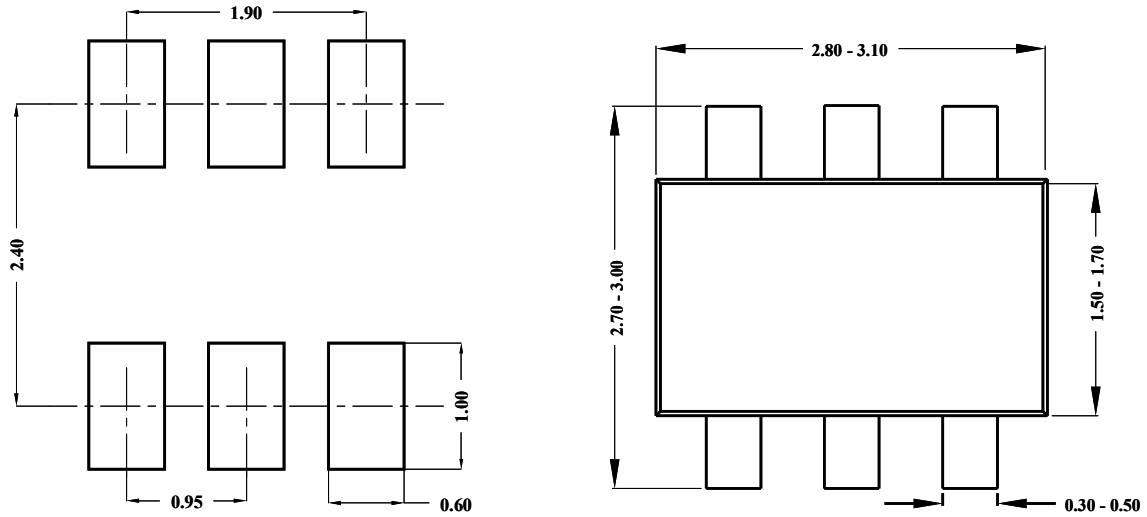

### Recommended Pad Layout

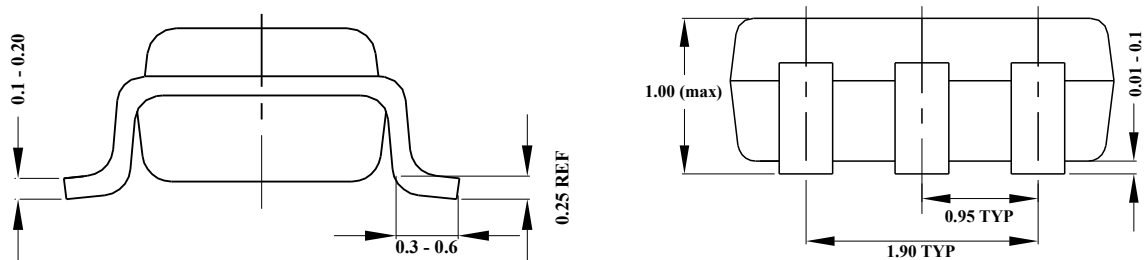

**Notes:** All dimensions are in millimeters.  
All dimensions don't include mold flash & metal burr

## DFN2x2-6 Package outline & PCB layout

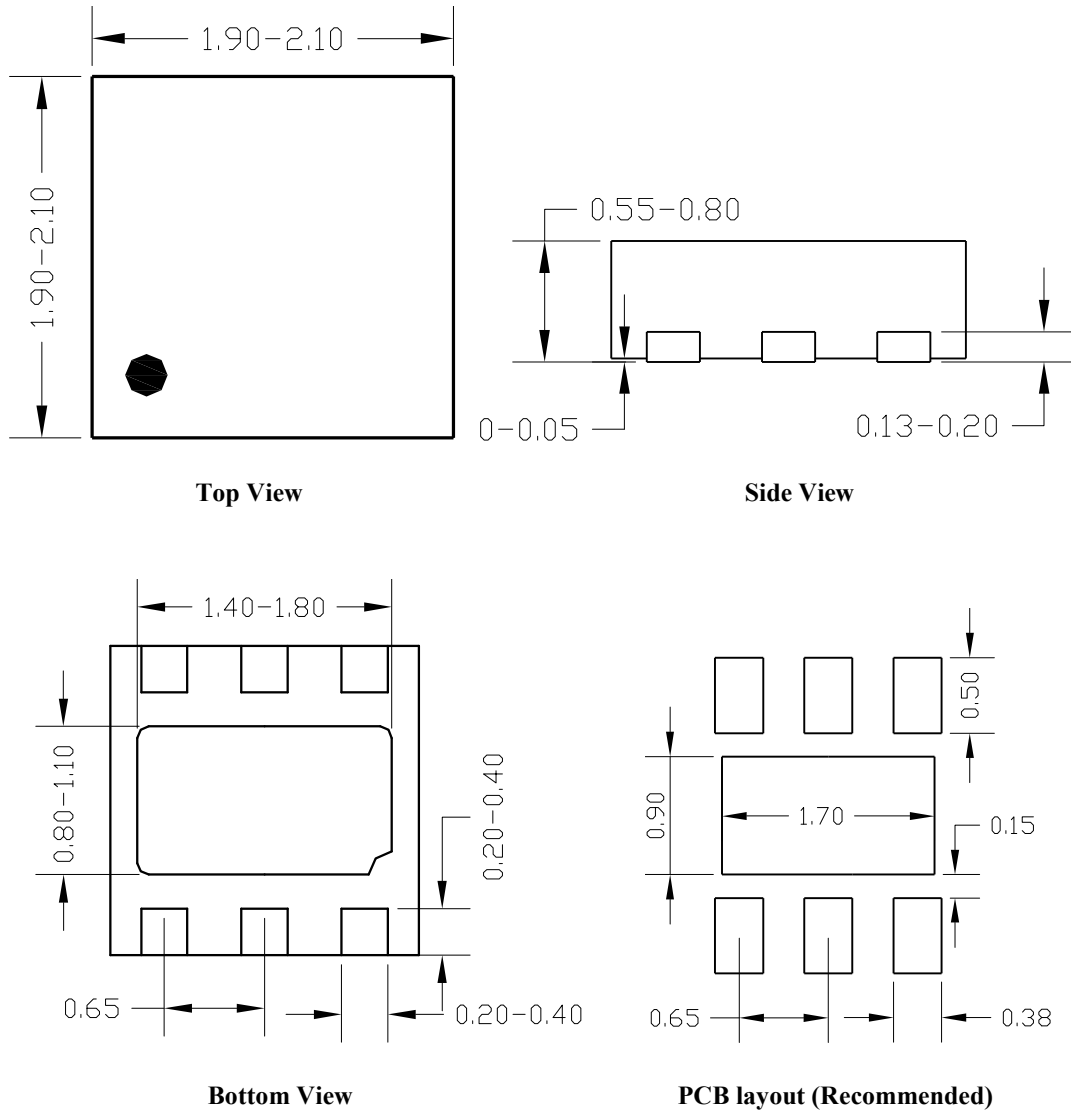

**Notes:** All dimensions are in millimeters.  
All dimensions don't include mold flash & metal burr.

## X-ON Electronics

Largest Supplier of Electrical and Electronic Components

*Click to view similar products for [LED Display Drivers](#) category:*

*Click to view products by [Silergy](#) manufacturer:*

Other Similar products are found below :

[STP16CPP05XTTR](#) [SCT2027CSSG](#) [KP22306WGA](#) [WS9088AS7P](#) [GN1628T](#) [BCT3236EGH-TR](#) [HT1628BRWZ](#) [KP1192SPA](#) [KP1182SPA](#)  
[KP1262FSPA](#) [KP1072LSPA](#) [KP1191SPA](#) [KP18001WPA](#) [KP1221SPA](#) [GN1640T](#) [MBI5253GP-A](#) [MBI5124GM-B](#) [WS90561T](#) [S7P](#)  
[WS9821B](#) [S7P](#) [WS9032GS7P](#) [74HC595D](#) [PJL4115SR](#) [SY8718A1ADC](#) [TM1651\(TA2007\)](#) [TM1616\(TA1323C\)](#) [TM1617\(TA1323C\)](#)  
[TM1628A](#) [TM1834](#) [TM512AC](#) [TM512ADH](#) [TM1923](#) [TM1805](#) [TM1914A](#) [TM1829](#) [TM1668\(TA1323C\)](#) [AW9963CSR](#) [WS2811M](#)  
[SY8703BABC](#) [SY7311AADC](#) [HT8402ARTZ](#) [MT7860](#) [OB3638CPA](#) [JW1965BSOPA#TRPBF](#) [JW1680OSOPB#TRPBF](#) [TM3100](#) [MT7938](#)  
[SM2255E](#) [MT7712SH](#) [STI9287CA](#) [U6113](#)