

## Ultra Low Quiescent Current 1.25MHz, 4A Synchronous Step Down Regulator

### General Description

SY8047 is a high efficiency ultra low quiescent current, 1.25MHz synchronous step-down DC-DC regulator IC capable of delivering up to 4A output current.

SY8047 operates over a wide input voltage range from 2.5V to 5.5V and integrates main switch and synchronous switch with very low  $R_{DS(ON)}$  to minimize the conduction loss.

### Ordering Information

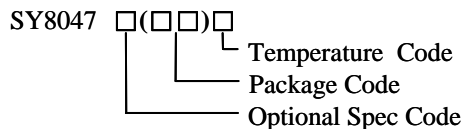

| Ordering Number | Package Type | Note |
|-----------------|--------------|------|
| SY8047QDC       | QFN3x3-16    | 4A   |

### Features

- Input voltage range: 2.5V to 5.5V
- 1.25MHz switching frequency
- Max output current: 4.0A
- Peak current mode control for the fast transient speed
- 100% drop out function
- Typical 18uA quiescent current
- Low  $R_{DS(ON)}$  for internal switches (PFET/NFET): 75mΩ/55mΩ
- Hic-cup mode protection for hard short condition
- RoHS Compliant and Halogen Free
- Compact package: QFN3x3-16

### Applications

- Set Top Box
- Net PC
- Mini-Notebook PC
- Access Point Router

### Typical Applications

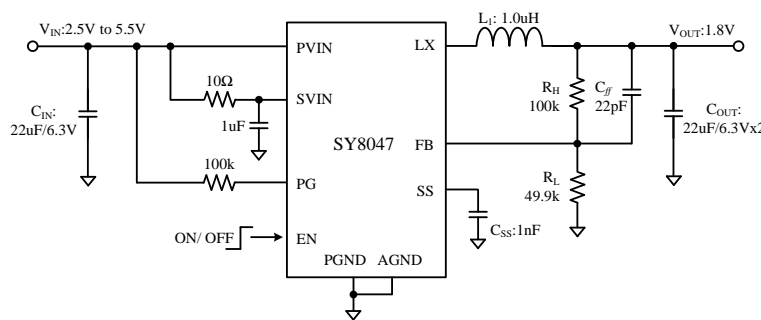

Figure 1. Schematic Diagram

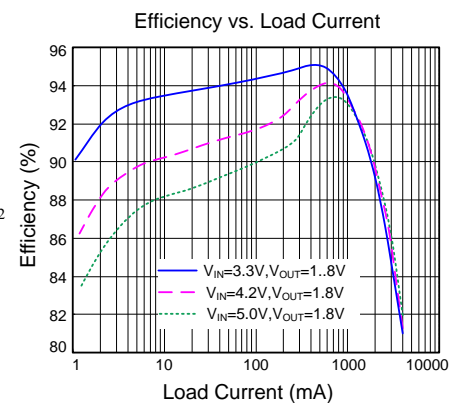
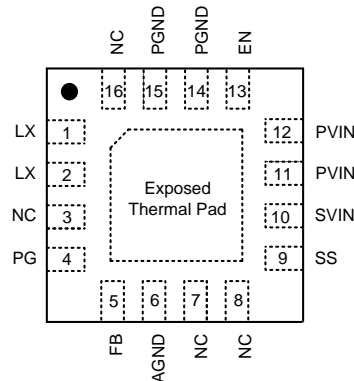

Figure 2. Efficiency Figure

## Pinout (top view)



| Part Number | Package type | Top Mark <sup>Ⓞ</sup> |
|-------------|--------------|-----------------------|
| SY8047QDC   | QFN3x3-16    | VJxyz                 |

Note ①: x=year code, y=week code, z=lot number code.

| Pin Name | Pin Number  | Pin Description   |
|----------|-------------|---|
| LX       | 1, 2        | Inductor pin. Connect this pin to the switching node of inductor  |
| NC       | 3, 7, 8, 16 | No connection   |
| PG       | 4           | Power good indicator(Open drain output). Low if the output < 90% of regulation voltage; High otherwise. Connect a pull-up resistor to the input.  |
| FB       | 5           | Output feedback pin. Connect this pin to the center point of the output resistor divider (as shown in Figure 1) to program the output voltage:<br>$V_{OUT}=0.6V*(1+R_H/R_L)$ .                        |
| AGND     | 6           | Analog ground pin.  |
| SS       | 9           | Soft-start programming pin. Do not float this pin. Connect a capacitor from this pin to ground to program the soft-start time. $t_{SS}=\text{Max}(60\mu\text{s}, C_{SS}\times 0.6V/1.6\mu\text{A})$ . |
| SVIN     | 10          | Supply voltage for control circuit. Decouple this pin to ground with at least 1uF ceramic cap.  |
| PVIN     | 11, 12      | Supply voltage for power circuit. Decouple this pin to ground with at least 22uF ceramic cap.   |
| EN       | 13          | Enable input pin. Integrated 4MΩ pull down resistor.  |
| PGND     | 14, 15      | Power ground pin.   |

## Absolute Maximum Ratings (Note 1)

|  |       |                  |
|--|-------|------------------|
| All pins   | ----- | 6V               |
| Power Dissipation, P <sub>D</sub> @ T <sub>A</sub> = 25 °C, QFN3x3 | ----- | 2.6W             |
| Package Thermal Resistance (Note 2)                                |       |                  |
| θ <sub>JA</sub>  | ----- | 38 °C/W          |
| θ <sub>JC</sub>  | ----- | 8 °C/W           |
| Junction Temperature Range   | ----- | 150 °C           |
| Lead Temperature (Soldering, 10 sec.)                              | ----- | 260 °C           |
| Storage Temperature Range  | ----- | -65 °C to 150 °C |

## Recommended Operating Conditions (Note 3)

|                            |       |                  |
|----------------------------|-------|------------------|
| Supply Input Voltage       | ----- | 2.5V to 5.5V     |
| Junction Temperature Range | ----- | -40 °C to 125 °C |
| Ambient Temperature Range  | ----- | -40 °C to 85 °C  |

## Electrical Characteristics

(V<sub>IN</sub> = 5V, V<sub>OUT</sub> = 2.5V, L = 1.0uH, C<sub>OUT</sub> = 22uF×2, T<sub>A</sub> = 25 °C, unless otherwise specified)

| Parameter                             | Symbol              | Test Conditions   | Min   | Typ  | Max   | Unit |
|---------------------------------------|---------------------|---|-------|------|-------|------|
| Input Voltage Range                   | V <sub>IN</sub>     |   | 2.5   |      | 5.5   | V    |
| Quiescent Current                     | I <sub>Q</sub>      | I <sub>OUT</sub> =0, V <sub>FB</sub> =V <sub>REF</sub> · 105% |       | 18   |       | μA   |
| Shutdown Current                      | I <sub>SHDN</sub>   | EN=0  |       | 0.1  | 1     | μA   |
| Feedback Reference Voltage            | V <sub>REF</sub>    |   | 0.591 | 0.6  | 0.609 | V    |
| PFET RON                              | R <sub>DSON,P</sub> |   |       | 75   |       | mΩ   |
| NFET RON                              | R <sub>DSON,N</sub> |   |       | 55   |       | mΩ   |
| Peak Current Limit                    | I <sub>LIM</sub>    |   | 5     |      |       | A    |
| EN rising threshold                   | V <sub>ENH</sub>    |   | 1.5   |      |       | V    |
| EN falling threshold                  | V <sub>ENL</sub>    |   |       |      | 0.4   | V    |
| Input UVLO threshold                  | V <sub>UVLO</sub>   |   |       |      | 2.5   | V    |
| UVLO hysteresis                       | V <sub>HYS</sub>    |   |       | 0.15 |       | V    |
| Oscillator Frequency                  | F <sub>OSC</sub>    | I <sub>OUT</sub> =500mA                                       |       | 1.25 |       | MHz  |
| PGOOD Under-voltage Threshold         | V <sub>FB,LV</sub>  |   |       | 0.55 |       | V    |
| Short Circuit Protection Threshold    | V <sub>SCP</sub>    |   |       | 0.26 |       | V    |
| Min ON Time                           |                     |   |       | 80   |       | ns   |
| Soft Start Current                    | I <sub>SS</sub>     | $T_{SS} = \frac{0.6V \times C_{SS}}{I_{SS}}$                  |       | 1.6  |       | μA   |
| Soft Start time                       | T <sub>SS</sub>     | C <sub>SS</sub> =1nF  |       | 400  |       | μs   |
| Output Discharge Switch On Resistance | R <sub>DSC</sub>    |   |       | 50   |       | Ω    |
| Thermal Shutdown Temperature          | T <sub>SD</sub>     |   |       | 150  |       | °C   |
| Thermal Shutdown Hysteresis           | T <sub>HYS</sub>    |   |       | 15   |       | °C   |

**Note 1:** Stresses beyond the “Absolute Maximum Ratings” may cause permanent damage to the device. These are stress ratings only. Functional operation of the device at these or any other conditions beyond those indicated in the operational sections of the specification is not implied. Exposure to absolute maximum rating conditions for extended periods may affect device reliability.

**Note 2:** θ<sub>JA</sub> is measured in the natural convection at T<sub>A</sub> = 25 °C on a low effective single layer thermal conductivity test board of JEDEC 51-3 thermal measurement standard.

**Note 3:** The device is not guaranteed to function outside its operating conditions.

**Block Diagram**

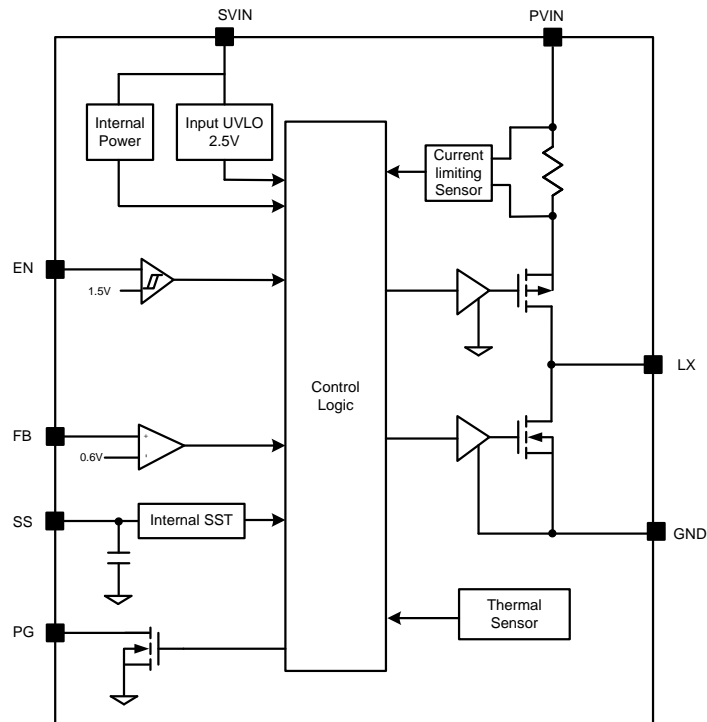

## QFN3x3-16 Package outline & PCB Layout

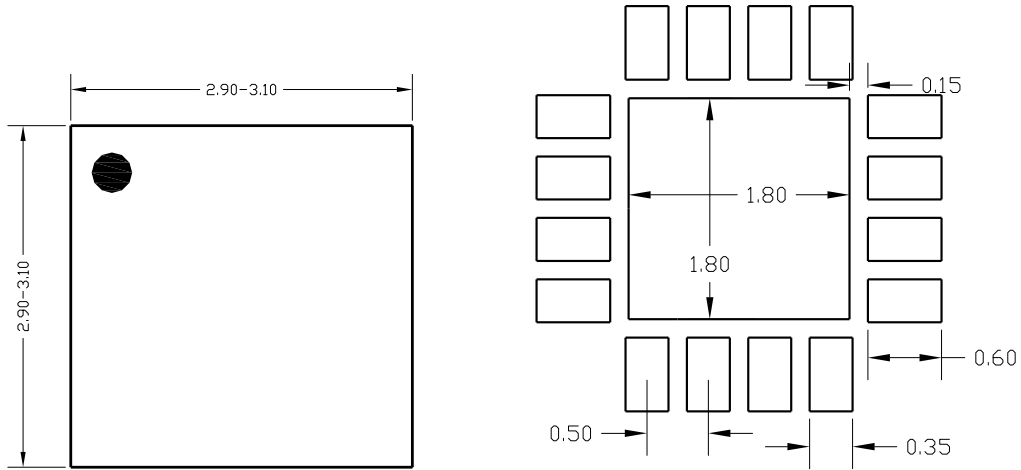

**Top View**

**PC B layout (Recommended)**

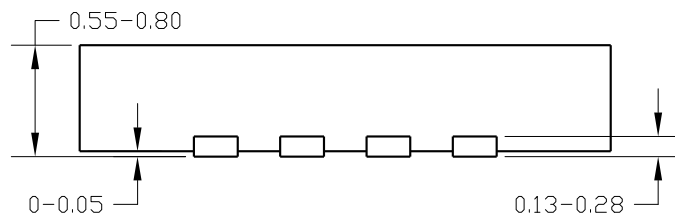

**Side View**

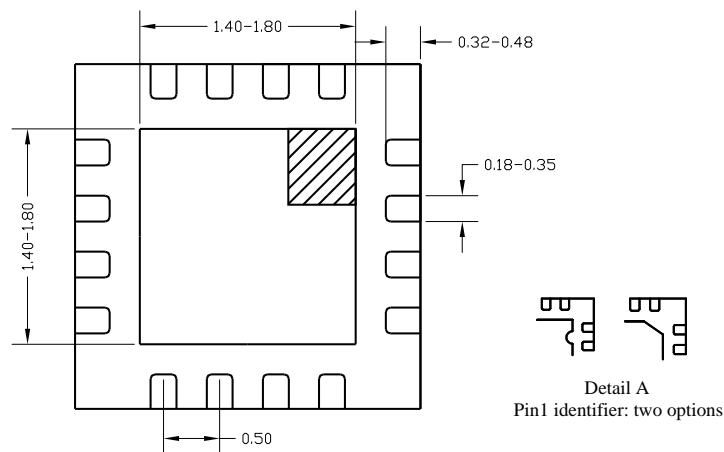

**Bottom View**

**Notes: All dimension in millimeter and exclude mold flash & metal burr.**

**Taping & Reel Specification**

**1. QFN3x3-16 taping orientation**

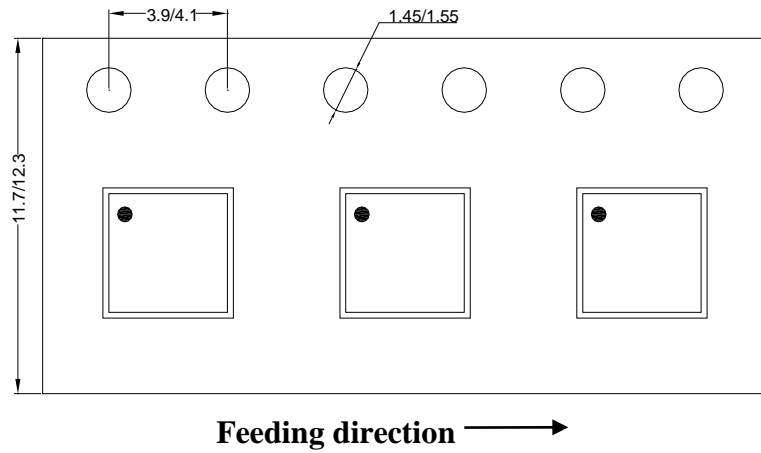

**2. Carrier Tape & Reel specification for packages**

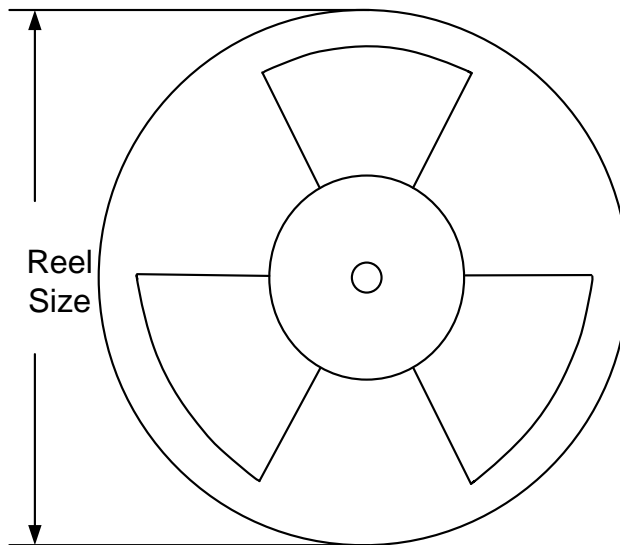

| Package types | Tape width (mm) | Pocket pitch(mm) | Reel size (Inch) | Trailer length(mm) | Leader length (mm) | Qty per reel |
|---------------|-----------------|------------------|------------------|--------------------|--------------------|--------------|
| QFN3x3        | 12              | 8                | 13"              | 400                | 400                | 5000         |

**3. Others: NA**

## X-ON Electronics

Largest Supplier of Electrical and Electronic Components

*Click to view similar products for [Switching Controllers](#) category:*

*Click to view products by [Silergy](#) manufacturer:*

Other Similar products are found below :

[LV5065VB-TLM-H](#) [LV5066V-TLM-H](#) [LV5725JAZ-AH](#) [NCP1218AD65R2G](#) [NCP1234AD100R2G](#) [NCP1244BD065R2G](#) [NCP1336ADR2G](#)  
[NCP1587GDR2G](#) [NCP6153MNTWG](#) [NCP81005MNTWG](#) [NCP81101BMNTXG](#) [NCP81205MNTXG](#) [CAT874-80ULGT3](#) [SJ6522AG](#)  
[SJE6600](#) [AZ7500BMTR-E1](#) [IR35215MTRPBF](#) [SG3845DM](#) [NCP4204MNTXG](#) [NCP6132AMNR2G](#) [NCP81102MNTXG](#)  
[NCP81203MNTXG](#) [NCP81206MNTXG](#) [UBA2051C](#) [IR35201MTRPBF](#) [NCP1240AD065R2G](#) [NCP1240FD065R2G](#)  
[NCP1361BABAYSNT1G](#) [NCP1230P100G](#) [NX2124CSTR](#) [SG2845M](#) [NCP1366BABAYDR2G](#) [NCP81101MNTXG](#) [TEA19362T/1J](#)  
[NCP81174NMNTXG](#) [NCP4308DMTTWG](#) [NCP4308DMNTWG](#) [NCP4308AMTTWG](#) [NCP1366AABAYDR2G](#) [NCP1251FSN65T1G](#)  
[NCP1246BLD065R2G](#) [iW1760B-10](#) [MB39A136PFT-G-BND-ERE1](#) [NCP1256BSN100T1G](#) [LV5768V-A-TLM-E](#) [NCP1365BABCYDR2G](#)  
[NCP1365AABCYDR2G](#) [MCP1633T-E/MG](#) [MCP1633-E/MG](#) [NCV1397ADR2G](#)