

High Efficiency, 800kHz, 40V Input, 2A Asynchronous Step Down Regulator

General Description

The SY8292 is a high efficiency 800 kHz, adaptive constant OFF time controlled asynchronous step-down DC/DC regulator capable of delivering 2A output current. The SY8292 can operate over a wide input voltage range from 5V to 40V and integrate main switch with very low $R_{DS(ON)}$ to minimize the conduction loss.

Low output voltage ripple and small external inductor and capacitor sizes are achieved with 800 kHz switching frequency.

Ordering Information

SY8292 □(□□)□
 □ Temperature Code
 □ Package Code
 □ Optional Spec Code

Ordering Number	Package type	Note
SY8292ABC	SOT23-6	--

Features

- 5-40V Input Voltage Range
- Low $R_{DS(ON)}$ for Internal N-channel Power FET: 180 mΩ
- 800kHz Switching Frequency
- Adaptive Constant OFF Time Control
- Internal Soft-start Limits the Inrush Current
- 2% 0.6V Reference
- Hic-up Mode Short Circuit Protection
- Cycle-by-cycle Peak Current Limit
- Thermal Shutdown Protection
- RoHS Compliant and Halogen Free
- Compact Package: SOT23-6

Applications

- Set Top Box
- Portable TV
- Access Point Router
- DSL Modem
- LCD TV

Typical Applications

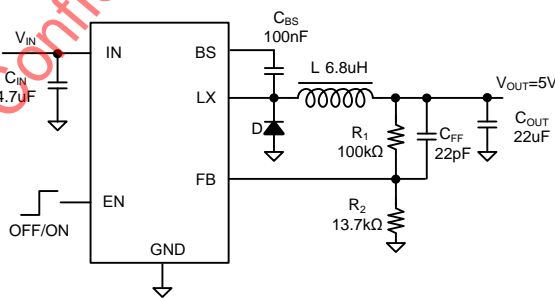

Figure 1. Schematic Diagram

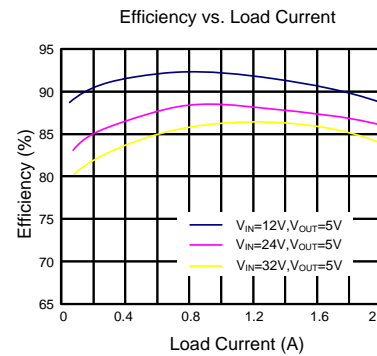
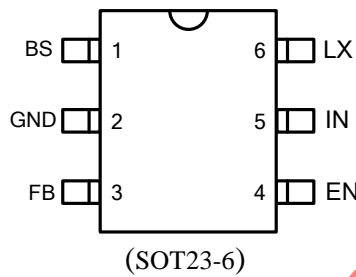

Figure2. Efficiency Figure

Pinout (top view)



Top Mark: HDxyz (Device code: HD, x=year code, y=week code, z= lot number code)

Pin Name	Pin Number	Pin Description
BS	1	Boot-strap pin. Supply high side gate driver. Connect a 0.1μF ceramic capacitor between the BS pin and the LX pin.
GND	2	Ground pin.
FB	3	Output feedback pin. Connect this pin to the center point of the output resistor divider (as shown in Figure 1) to program the output voltage: $V_{OUT}=0.6 \times (1+R_1/R_2)$
EN	4	Enable control. Pull high to turn on. Do not leave it floating.
IN	5	Input pin. Decouple this pin to the GND pin with at least a 4.7μF ceramic capacitor.
LX	6	Inductor pin. Connect this pin to the switching node of the inductor.

Block Diagram

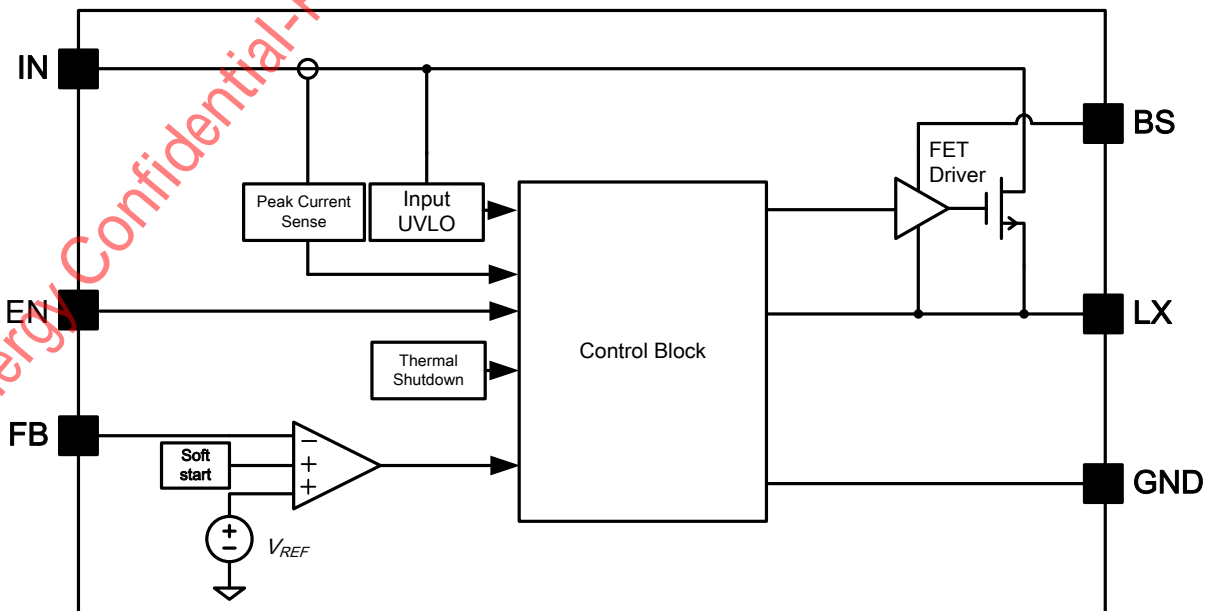

Absolute Maximum Ratings (Note 1)

Supply Input Voltage	-----	42V
Enable Voltage	-----	$V_{IN} + 0.6V$
FB Voltage	-----	3.6V
BS to LX Voltage	-----	3.6V
Power Dissipation, PD @ $T_A = 25\text{ }^\circ\text{C}$, SOT23-6	-----	0.6W
Package Thermal Resistance (Note 2)		
θ_{JA}	-----	170 $^\circ\text{C/W}$
θ_{JC}	-----	130 $^\circ\text{C/W}$
Junction Temperature Range	-----	150 $^\circ\text{C}$
Lead Temperature (Soldering, 10 sec.)	-----	260 $^\circ\text{C}$
Storage Temperature Range	-----	-65 $^\circ\text{C}$ to 150 $^\circ\text{C}$

Recommended Operating Conditions (Note 3)

Supply Input Voltage	-----	5V to 40V
BS to LX Voltage	-----	3.3V
Junction Temperature Range	-----	-40 $^\circ\text{C}$ to 125 $^\circ\text{C}$
Ambient Temperature Range	-----	-40 $^\circ\text{C}$ to 85 $^\circ\text{C}$

Silergy Confidential-For 深圳市立创电子商务有限公司

Electrical Characteristics

($V_{IN} = 12V$, $V_{OUT} = 5V$, $L=6.8\mu H$, $C_{OUT} = 22\mu F$, $T_A = 25\text{ }^\circ\text{C}$, $I_{OUT} = 1A$ unless otherwise specified)

Parameter	Symbol	Test Conditions	Min	Typ	Max	Unit
Input Voltage Range	V_{IN}		5		40	V
Input UVLO Threshold	V_{UVLO}	Rising		4.5		V
Input UVLO Threshold		Falling		4.3		V
Input UVLO Hysteresis	$V_{UVLO,HYS}$			200		mV
Quiescent Current	I_Q	$I_{OUT}=0$, $V_{FB}=V_{REF}\times 105\%$		160		μA
Shutdown Current	I_{SHDN}	EN=0			10	μA
Feedback Reference Voltage	V_{REF}		0.588	0.6	0.612	V
FB Input Current	I_{FB}	$V_{FB}=V_{IN}$	-50		50	nA
Power FET RON	$R_{DS(ON)}$			180		$m\Omega$
Power FET Current Limit	I_{LIM}		2.4			A
EN Rising Threshold	V_{ENH}		1.5			V
EN Falling Threshold	V_{ENL}				0.4	V
Minimum OFF Time	t_{OFF}				100	ns
Minimum ON Time	$t_{ON,MIN}$				100	ns
Maximum ON Time	$t_{ON,MAX}$			2		us
Oscillator Frequency	f_{OSC}			800		kHz
Soft-start Time	t_{SS}			500		μs
Thermal Shutdown Temperature	T_{SD}			150		$^\circ\text{C}$
Thermal Shutdown Recovery Hysteresis	T_{HYS}			15		$^\circ\text{C}$

Note 1: Stresses beyond the “Absolute Maximum Ratings” may cause permanent damage to the device. These are stress ratings only. Functional operation of the device at these or any other conditions beyond those indicated in the operational sections of the specification is not implied. Exposure to absolute maximum rating conditions for extended periods may affect device reliability.

Note 2: θ_{JA} is measured in the natural convection at $T_A = 25\text{ }^\circ\text{C}$ on a low effective single layer thermal conductivity test board of JEDEC 51-3 thermal measurement standard.

Note 3: The device is not guaranteed to function outside its operating conditions.

SOT23-6 Package Outline & PCB Layout Design

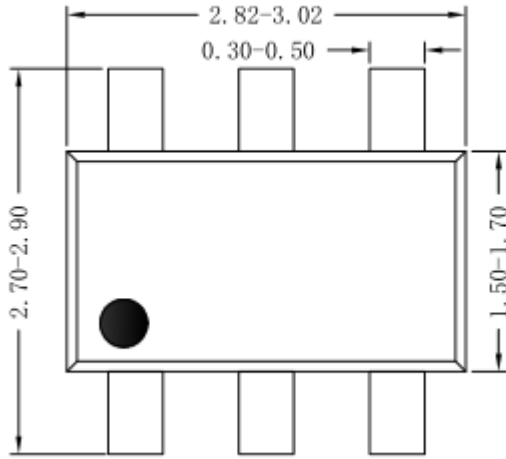

Top View

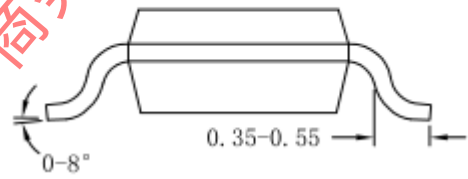

Side View

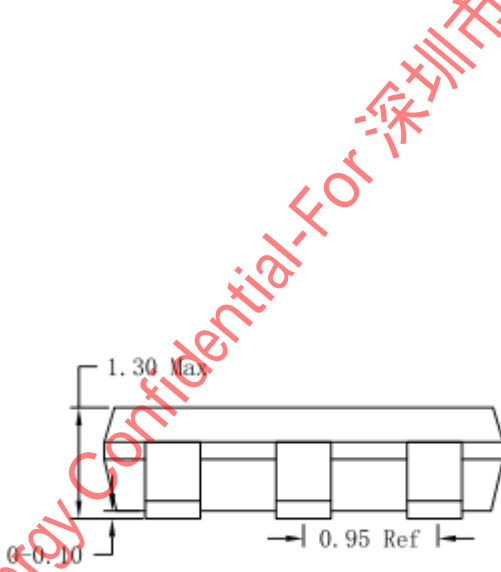

Side View

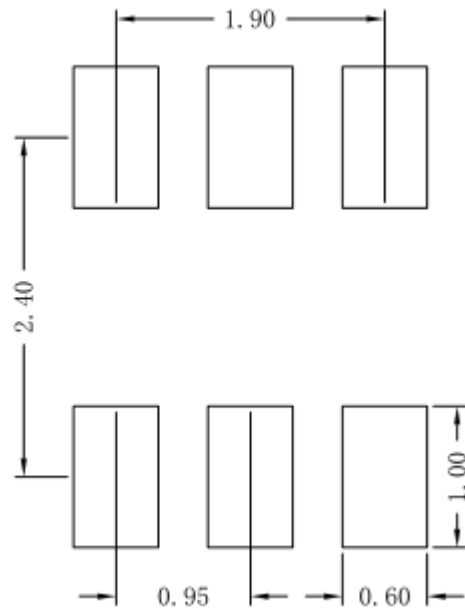

Recommended Pad Layout

Notes: All dimension in millimeter and exclude mold flash & metal burr.

Taping & Reel Specification

1. Taping orientation for package

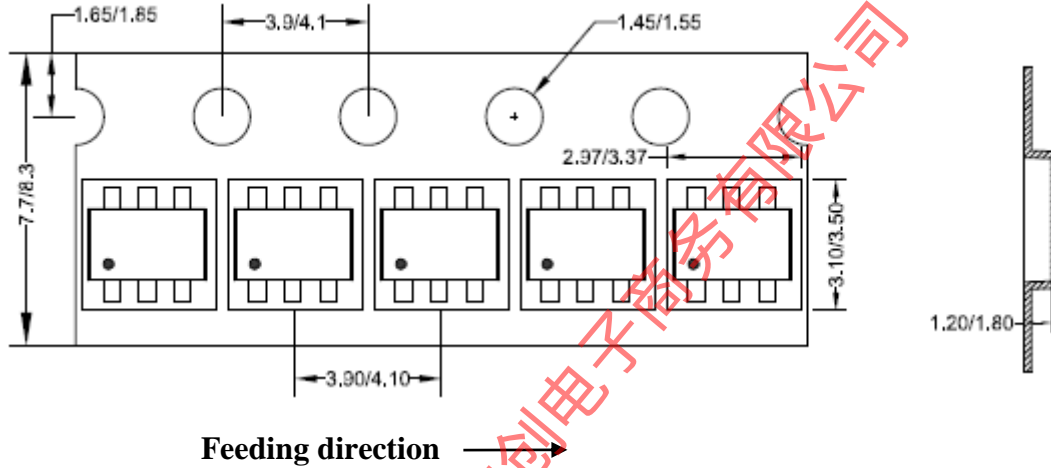

2. Carrier Tape & Reel specification for packages

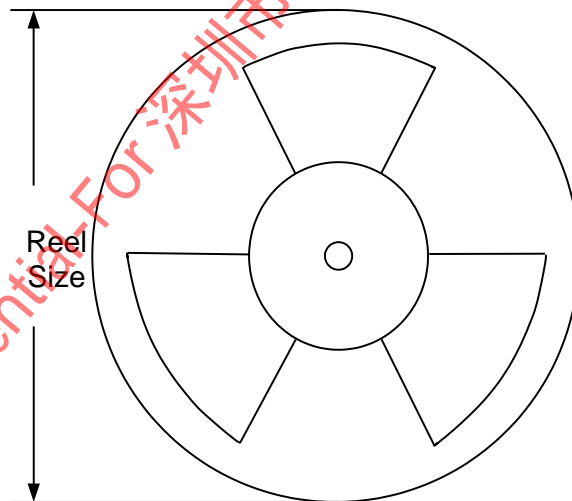

Package type	Tape width (mm)	Pocket pitch(mm)	Reel size (Inch)	Trailer length(mm)	Leader length (mm)	Qty per reel
SOT23-6	8	4	7"	280	160	3000

3. Others: NA

X-ON Electronics

Largest Supplier of Electrical and Electronic Components

Click to view similar products for [Switching Controllers](#) category:

Click to view products by [Silergy](#) manufacturer:

Other Similar products are found below :

[NCP1218AD65R2G](#) [NCP1244BD065R2G](#) [NCP6153MNTWG](#) [NCP81101BMNTXG](#) [NCP81205MNTXG](#) [SJE6600](#) [SG3845DM](#)
[NCP4204MNTXG](#) [NCP6132AMNR2G](#) [NCP81102MNTXG](#) [NCP81206MNTXG](#) [MAX1653ESET](#) [NCP1240FD065R2G](#)
[NCP1361BABAYSNT1G](#) [NCP1230P100G](#) [NX2124CSTR](#) [NCP1366BABAYDR2G](#) [NCP81174NMNTXG](#) [NCP4308DMTTWG](#)
[NCP4308AMTTWG](#) [NCP1366AABAYDR2G](#) [NCP1251FSN65T1G](#) [NCP1246BLD065R2G](#) [NTE7233](#) [ISL69122IRAZ](#) [MB39A136PFT-G-](#)
[BND-ERE1](#) [NCP1256BSN100T1G](#) [LV5768V-A-TLM-E](#) [NCP1365BABCYDR2G](#) [NCP1365AABCYDR2G](#) [NCP1246ALD065R2G](#)
[AZ494AP-E1](#) [CR1510-10](#) [NCP4205MNTXG](#) [XC9221C093MR-G](#) [XRP6141ELTR-F](#) [RY8017](#) [LP6260SQVF](#) [LP6298QVF](#) [ISL6121LIB](#)
[ISL6225CA](#) [ISL6244HRZ](#) [ISL6268CAZ](#) [ISL6315IRZ](#) [ISL6420AIAZ-TK](#) [ISL6420AIRZ](#) [ISL6420IAZ](#) [ISL6421ERZ](#) [ISL6440IA](#)
[ISL6441IRZ-TK](#)