



Application Notes: AN_SY8368

High Efficiency Fast Response 8A Continuous, 16A Peak, 28V Input Synchronous Step Down Regulator

General Description

The SY8368 develops a high efficiency synchronous step-down DC-DC regulator capable of delivering 8A continuous, 16A peak current. The SY8368 operates over a wide input voltage range from 4V to 28V and integrates main switch and synchronous switch with very low $R_{DS(ON)}$ to minimize the conduction loss.

The SY8368 adopts the instant PWM architecture to achieve fast transient responses for high step down applications and high efficiency at light loads. In addition, it operates at pseudo-constant frequency of 800kHz under continuous conduction mode to minimize the size of inductor and capacitor.

Ordering Information

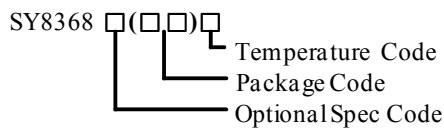

Ordering Number	Package type	Note
SY8368QNC	QFN3x3-10	--

Features

- Low $R_{DS(ON)}$ for internal switches (top/bottom): 20/10 m Ω
- Wide input voltage range: 4-28V
- Instant PWM architecture to achieve fast transient responses
- Internal 400uS softstart limits the inrush current
- Pseudo-constant frequency: 800kHz.
- 8A continuous/16A peak output current capability
- $\pm 1.5\%$ 0.6V reference
- Programmable peak current limit
- Power good indicator
- Output discharge function
- Short circuit latch off protection
- Over voltage latch off protection
- Input UVLO
- Over temperature protection
- RoHS Compliant and Halogen Free
- Compact package: QFN3x3-10

Applications

- LCD-TV/Net-TV/3DTV
- Set Top Box
- Notebook
- High Power AP

Typical Applications

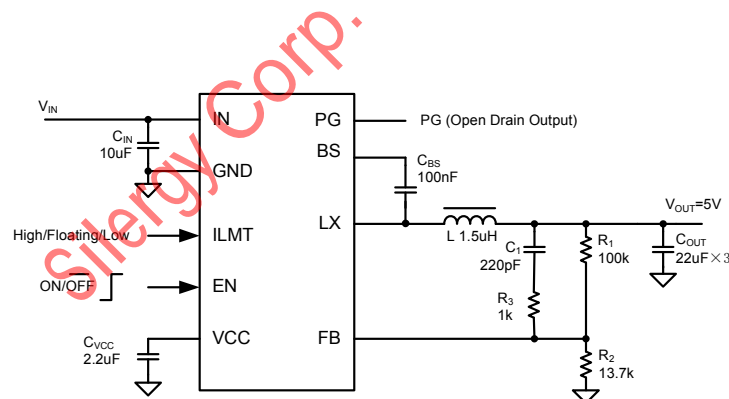

Figure 1 Schematic

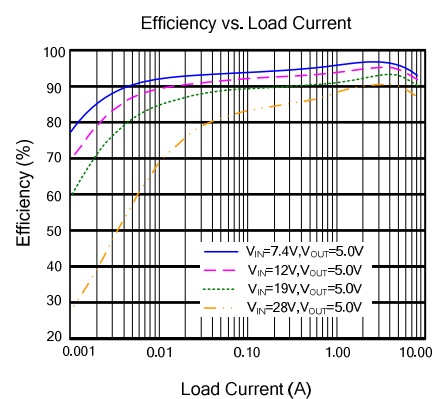
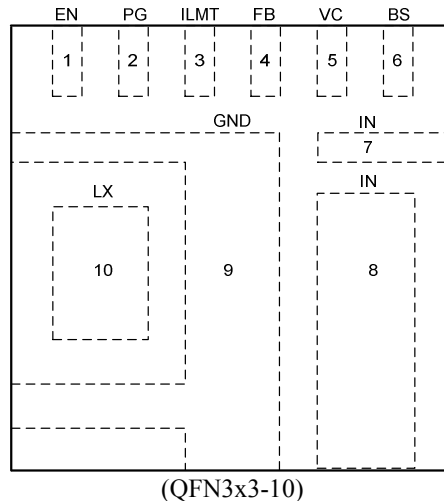

Figure 2. Efficiency



Pinout (top view)



Top Mark: YW_{xyz}, (Device code: YW, x=*year code*, y=*week code*, z=*lot number code*)

Pin Name	Pin Number	Pin Description
EN	1	Enable control. Pull this pin high to turn on the IC. Do not leave this pin floating.
PG	2	Power good Indicator. Open drain output when the output voltage is within 90% to 120% of regulation point.
ILMT	3	Current limit setting pin. The current limit is set to 8A, 12A or 16A when this pin is pull low, floating or pull high respectively.
FB	4	Output Feedback Pin. Connect this pin to the center point of the output resistor divider (as shown in Figure 1) to program the output voltage: $V_{out}=0.6*(1+R1/R2)$
VC	5	Internal 3.3V LDO output. Power supply for internal analog circuits and driving circuit. Bypass a capacitor to GND.
BS	6	Boot-Strap Pin. Supply high side gate driver. Decouple this pin to LX pin with 0.1uF ceramic cap.
IN	7,8	Input pin. Decouple this pin to GND pin with at least 10uF ceramic cap
GND	9	Ground pin
LX	10	Inductor pin. Connect this pin to the switching node of inductor



Absolute Maximum Ratings (Note 1)

IN, LX, PG, EN	-----	-0.3V to 30V
BS-LX, FB, ILMT, VCC	-----	-0.3V to 4V
Power Dissipation, PD @ T _A = 25°C QFN3x3-10	-----	-3.3W
Package Thermal Resistance (Note 2)		
θ _{JA}	-----	30°C/W
θ _{JC}	-----	4°C/W
Junction Temperature Range	-----	125°C
Lead Temperature (Soldering, 10 sec.)	-----	260°C
Storage Temperature Range	-----	-65°C to 150°C
Dynamic LX voltage in 50ns duration	-----	IN+3V to GND-4V

Recommended Operating Conditions (Note 3)

Supply Input Voltage	-----	4V to 28V
Junction Temperature Range	-----	-40°C to 125°C
Ambient Temperature Range	-----	-40°C to 85°C

Block Diagram

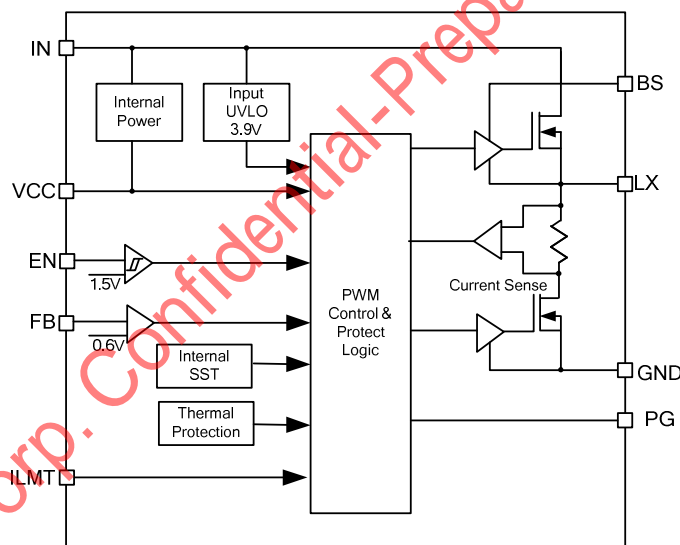



Electrical Characteristics

($V_{IN} = 12V$, $V_{OUT} = 5V$, $C_{OUT} = 100\mu F$, $T_A = 25^\circ C$, $I_{OUT} = 2A$ unless otherwise specified)

Parameter	Symbol	Test Conditions	Min	Typ	Max	Unit
Input Voltage Range	V_{IN}		4.0		28	V
Quiescent Current	I_Q	$I_{OUT} = 0$, $V_{FB} = V_{REF} * 105\%$			100	μA
Shutdown Current	I_{SHDN}	EN=0		3	10	μA
Feedback Reference Voltage	V_{REF}		0.591	0.6	0.609	V
FB Input Current	I_{FB}	$V_{FB} = 4V$	-50		50	nA
Top FET RON	Rds(on)1			20		m Ω
Bottom FET RON	Rds(on)2			10		m Ω
Discharge FET RON	Rdis			50		Ω
Bottom FET Current Limit	I_{LIM}	ILMT='0'	8			A
		ILMT=Floating	12			
		ILMT='1'	16			
ILMT Rising Threshold	V_{ILMTH}		$V_{CC} - 0.8$		V_{CC}	V
ILMT Falling Threshold	V_{ILMTL}				0.8	V
ILMT Floating Threshold	V_{ILMIF}		1.3		2	V
Soft Start Time	T_{SS}			400		μS
EN Rising Threshold	V_{ENH}		0.8			V
EN Falling Threshold	V_{ENL}				0.4	V
Input UVLO Threshold	V_{UVLO}				3.9	V
UVLO hysteresis	V_{HYS}			0.3		V
Oscillator Frequency	F_{OSC}	$V_O = 5V$	0.68	0.8	0.92	MHz
Min ON Time	$T_{ON,MIN}$	$V_{IN} = V_{INMAX}$		50		ns
Min OFF Time	$T_{OFF,MIN}$			80		ns
VCC Output	V_{CC}	$V_{IN} = 4V$	3.2	3.3	3.4	V
Output Over Voltage Threshold		V_{FB} Rising	115	120	125	$\%V_{REF}$
Output Over Voltage Hysteresis				2		$\%V_{REF}$
Output Over Voltage Delay Time				20		μS
Power Good Threshold		V_{FB} Rising (Good)	88	90	92	$\%V_{REF}$
Power Good Hysteresis				2		$\%V_{REF}$
Power Good Delay Time				10		μS
Thermal Shutdown Temperature	T_{SD}			150		$^\circ C$
Thermal Shutdown hysteresis	T_{HYS}			15		$^\circ C$

Note 1: Stresses beyond the “Absolute Maximum Ratings” may cause permanent damage to the device. These are stress ratings only. Functional operation of the device at these or any other conditions beyond those indicated in the operational sections of the specification is not implied. Exposure to absolute maximum rating conditions for extended periods may affect device reliability

Note 2: θ_{JA} is measured in the natural convection at $T_A = 25^\circ C$ on a four-layer Silergy Evaluation Board..

Note 3: The device is not guaranteed to function outside its operating conditions.

Typical Performance Characteristics

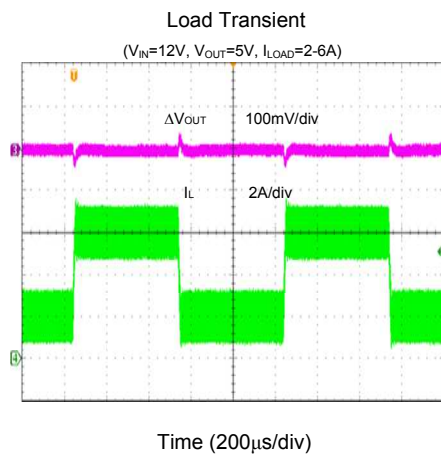
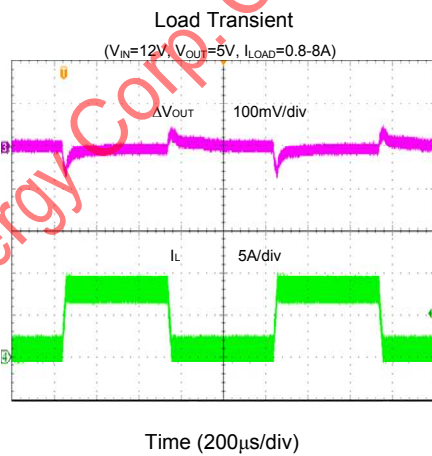
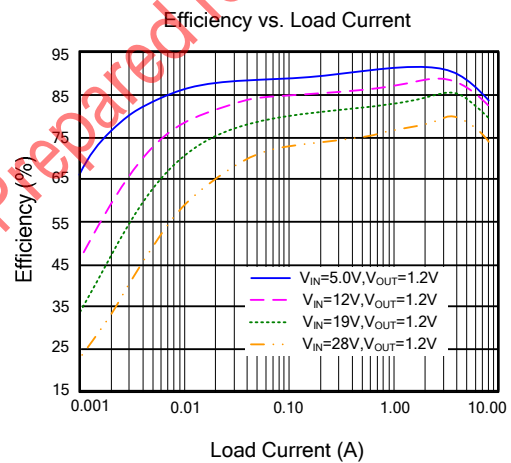
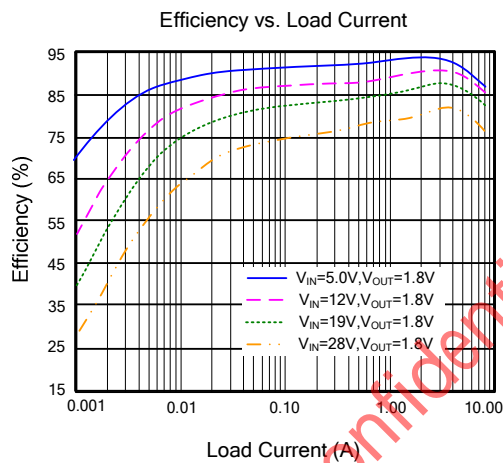
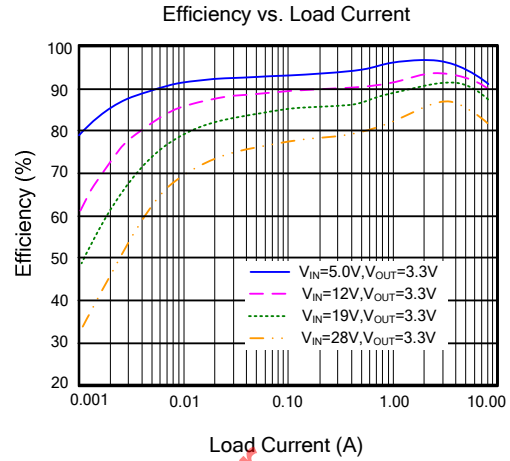
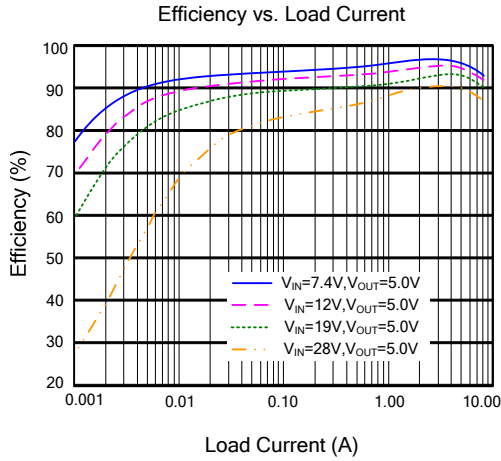

Startup from Enable

($V_{IN}=12V$, $V_{OUT}=5V$, $I_{LOAD}=8A$)

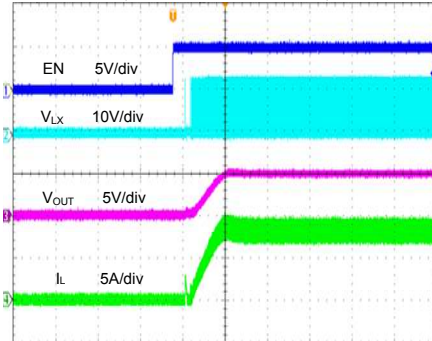

Time (400 μ s/div)

Shutdown from Enable

($V_{IN}=12V$, $V_{OUT}=5V$, $I_{LOAD}=8A$)

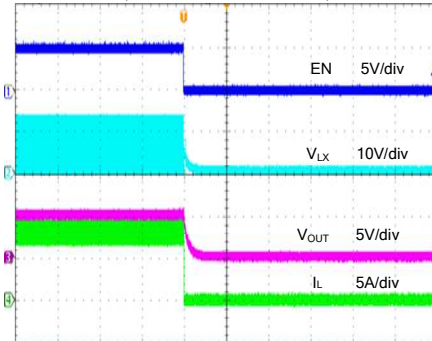

Time (400 μ s/div)

Startup from VIN

($V_{IN}=12V$, $V_{OUT}=5V$, $I_{LOAD}=8A$)

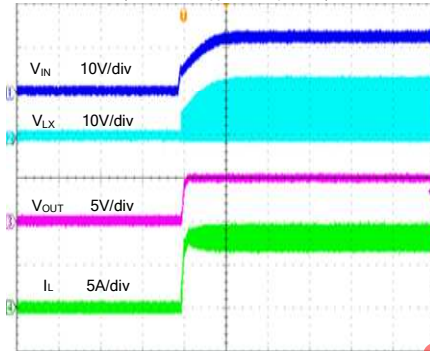

Time (4ms/div)

Shutdown from VIN

($V_{IN}=12V$, $V_{OUT}=5V$, $I_{LOAD}=8A$)

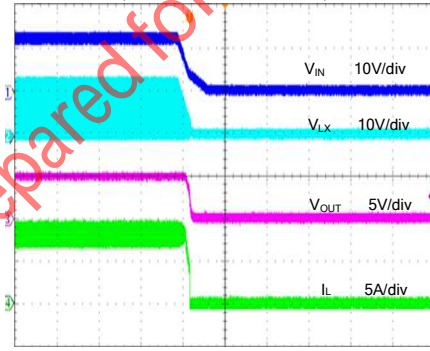

Time (2ms/div)

Short Circuit Protection

($V_{IN}=12V$, $V_{OUT}=5V$, ILMT floating, Null Load to Short)

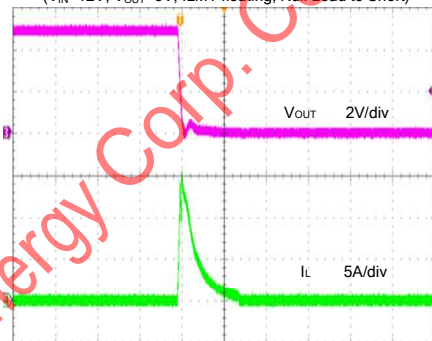

Time (100 μ s/div)

Short Circuit Protection

($V_{IN}=12V$, $V_{OUT}=5V$, ILMT floating, 8A to Short)

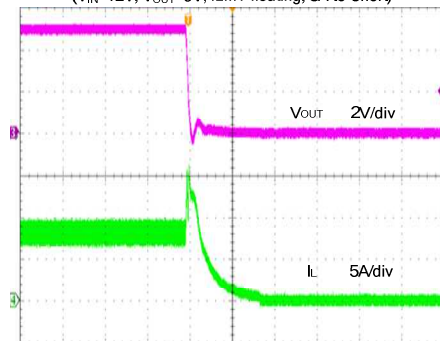

Time (100 μ s/div)

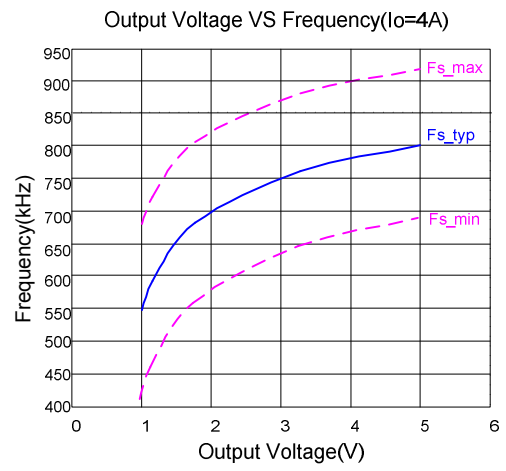
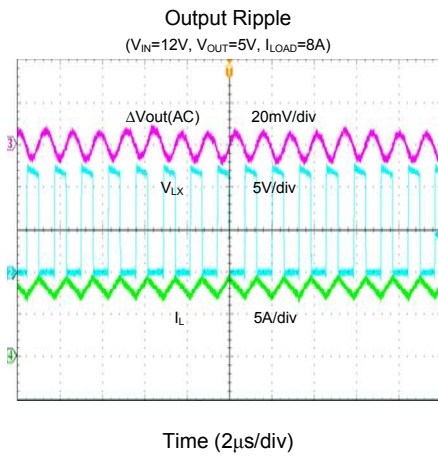

Silergy Corp. Confidential-Prepared for

Operation

The SY8368 develops a high efficiency synchronous step-down DC-DC regulator capable of delivering 8A continuous, 16A peak current. The SY8368 operates over a wide input voltage range from 4V to 28V and integrates main switch and synchronous switch with very low $R_{DS(ON)}$ to minimize the conduction loss.

The SY8368 adopts the instant PWM architecture to achieve fast transient responses for high step down applications and high efficiency at light loads. In addition, it operates at pseudo-constant frequency of 800kHz under continuous conduction mode to minimize the size of inductor and capacitor.

Applications Information

Because of the high integration in the SY8368 IC, the application circuit based on this regulator IC is rather simple. Only input capacitor C_{IN} , output capacitor C_{OUT} , output inductor L and feedback resistors (R_1 and R_2) need to be selected for the targeted applications specifications.

Feedback resistor dividers R_1 and R_2 :

Choose R_1 and R_2 to program the proper output voltage. To minimize the power consumption under light loads, it is desirable to choose large resistance values for both R_1 and R_2 . A value of between 10k Ω and 1M Ω is highly recommended for both resistors. If V_{OUT} is 3.3V, $R_1=100k$ is chosen, then using following equation, R_2 can be calculated to be 22.1k:

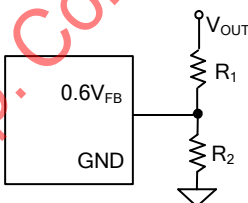
$$R_2 = \frac{0.6V}{V_{OUT} - 0.6V} R_1$$

Input capacitor C_{IN} :

The ripple current through input capacitor is calculated as:

$$I_{CIN_RMS} = I_{OUT} \cdot \sqrt{D(1-D)}$$

To minimize the potential noise problem, place a typical X5R or better grade ceramic capacitor really close to the IN and GND pins. Care should be taken to minimize the loop area formed by C_{IN} , and IN/GND pins. In this case, a 10uF low ESR ceramic capacitor is recommended.

Output capacitor C_{OUT} :

The output capacitor is selected to handle the output ripple noise requirements. Both steady state ripple and transient requirements must be taken into consideration when selecting this capacitor. For most applications, an X5R or better grade ceramic capacitor greater than 66uF capacitance can work well. The capacitance derating with DC voltage must be considered.

Output inductor L :

There are several considerations in choosing this inductor.

- 1) Choose the inductance to provide the desired ripple current. It is suggested to choose the ripple current to be about 40% of the maximum output current. The inductance is calculated as:

$$L = \frac{V_{OUT}(1 - V_{OUT}/V_{IN,MAX})}{F_{SW} \times I_{OUT,MAX} \times 40\%}$$

where F_{sw} is the switching frequency and $I_{OUT,MAX}$ is the maximum load current.

The SY8368 regulator IC is quite tolerant of different ripple current amplitude. Consequently, the final choice of inductance can be slightly off the calculation value without significantly impacting the performance.

- 2) The saturation current rating of the inductor must be selected to be greater than the peak inductor current under full load conditions.

$$I_{SAT, MIN} > I_{OUT, MAX} + \frac{V_{OUT}(1 - V_{OUT}/V_{IN,MAX})}{2 \cdot F_{SW} \cdot L}$$

- 3) The DCR of the inductor and the core loss at the switching frequency must be low enough to achieve the desired efficiency requirement. It is desirable to choose an inductor with $DCR < 10m\Omega$ to achieve a good overall efficiency.

Current limit setting

The current limit is set to 8A, 12A or 16A when ILMT pin is pull low, floating or pull high respectively.

Soft-start

The SY8368 has a built-in soft-start to control the rise rate of the output voltage and limit the input current surge during IC start-up. The typical soft-start time is 400us.

Enable Operation

Pulling the EN pin low (<0.4V) will shut down the device. During shutdown mode, the SY8368 shutdown current drops to lower than 10uA. Driving the EN pin high (>0.8V) will turn on the IC again.

External Bootstrap Cap

This capacitor provides the gate driver voltage for internal high side MOSEFET. A 100nF low ESR ceramic capacitor connected between BS pin and LX pin is recommended.

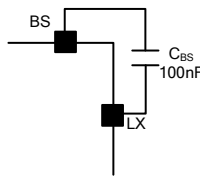

VCC LDO

The 3.3V VCC LDO provides the power supply for internal control circuit. Bypass this pin to ground with a 2.2uF ceramic capacitor.

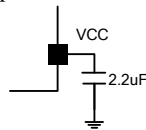

Power Good Indication

PG is an open drain output. This pin is externally pulled high when the FB voltage is within 90% to 120% of the internal reference voltage. Otherwise is pulled low.

Load Transient Considerations:

The SY8368 regulator IC adopts the instant PWM architecture to achieve good stability and fast transient responses. In applications with high step load current, adding an RC network R_{FF} and C_{FF} parallel with R_1

may further speed up the load transient responses.

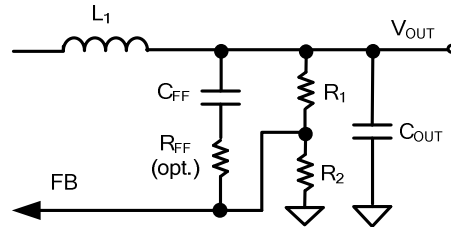

Layout Design:

The layout design of SY8368 regulator is relatively simple. For the best efficiency and minimum noise problem, we should place the following components close to the IC: C_{IN} , C_{VCC} , L , R_1 and R_2 .

1) It is desirable to maximize the PCB copper area connecting to GND pin to achieve the best thermal and noise performance. If the board space allowed, a ground plane is highly desirable.

2) C_{IN} must be close to Pins IN and GND. The loop area formed by C_{IN} and GND must be minimized.

3) The PCB copper area associated with LX pin must be minimized to avoid the potential noise problem.

4) The components R_1 and R_2 , and the trace connecting to the FB pin must NOT be adjacent to the LX net on the PCB layout to avoid the noise problem.

5) If the system chip interfacing with the EN pin has a high impedance state at shutdown mode and the IN pin is connected directly to a power source such as a Li-Ion battery, it is desirable to add a pull down 1Mohm resistor between the EN and GND pins to prevent the noise from falsely turning on the regulator at shutdown mode.

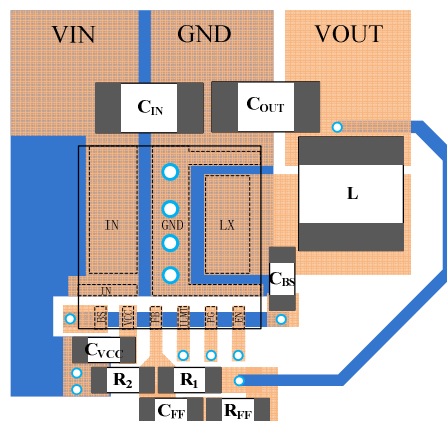

QFN3x3-10 FC Package Outline Drawing

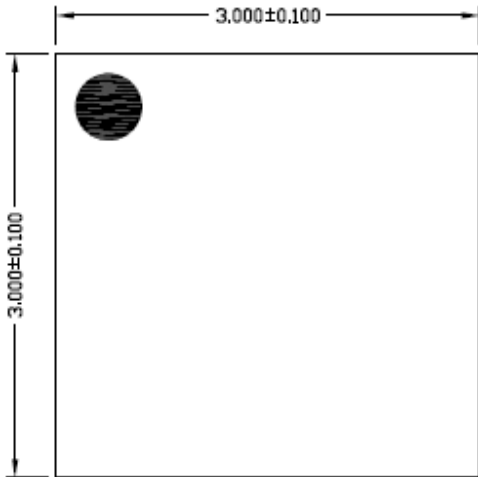

Top View

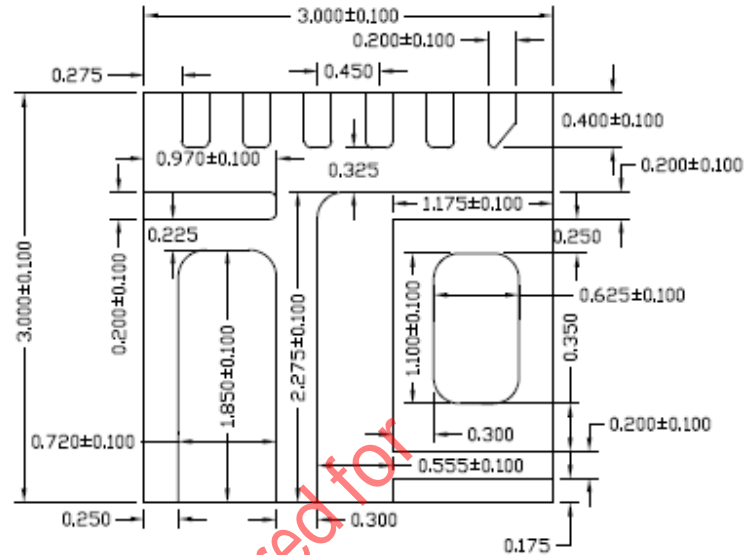

Bottom View



Side View

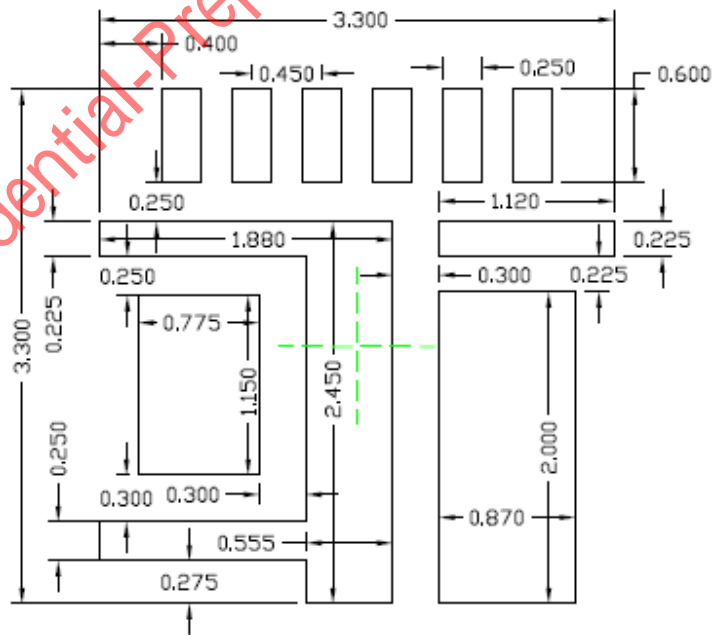

Recommended PCB Layout
(Reference only)

Notes: All dimension in MM and exclude mold flash & metal burr

Taping & Reel Specification

1. Taping orientation

QFN3x3

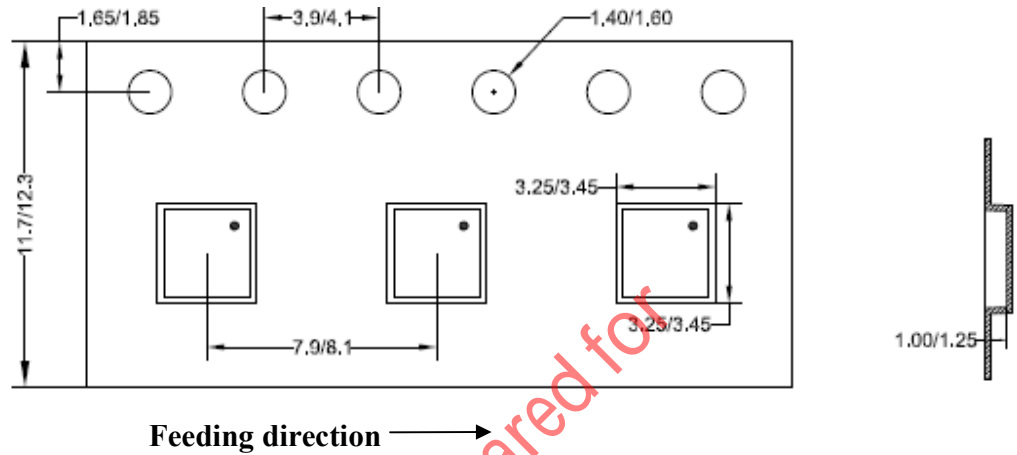

2. Carrier Tape & Reel specification for packages

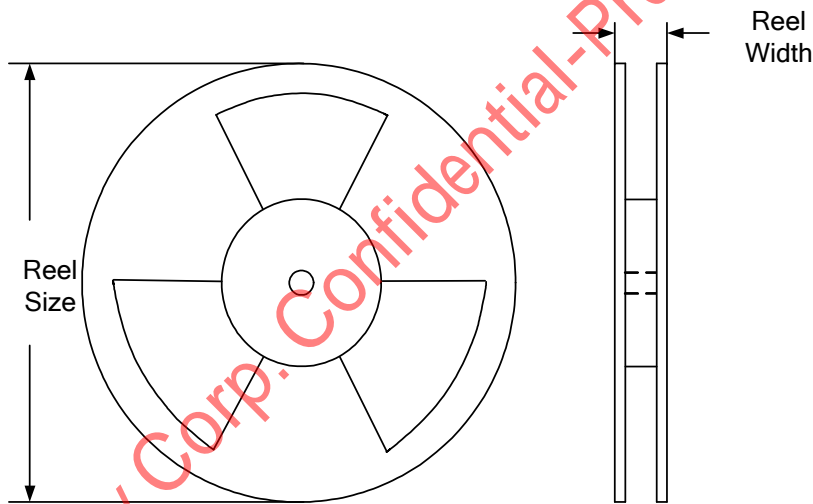

Package types	Tape width (mm)	Pocket pitch(mm)	Reel size (Inch)	Reel width(mm)	Trailer length(mm)	Leader length (mm)	Qty per reel
QFN3x3	12	8	13"	12.4	400	400	5000

3. Others: NA

X-ON Electronics

Largest Supplier of Electrical and Electronic Components

Click to view similar products for [Isolated DC/DC Converters](#) category:

Click to view products by [Silergy](#) manufacturer:

Other Similar products are found below :

[FMD15.24G](#) [PSL486-7LR](#) [Q48T30020-NBB0](#) [18362](#) [JAHW100Y1](#) [SPB05C-12](#) [SQ24S15033-PS0S](#) [19-130041](#) [CE-1003](#) [RDS180245](#)
[MAU228](#) [J80-0041NL](#) [DFC15U48D15](#) [XGS-1205](#) [NCT1000N040R050B](#) [SPB05B-15](#) [SPB05C-15](#) [L-DA20](#) [DCG40-5G](#) [QME48T40033-](#)
[PGB0](#) [AK1601-9RT](#) [DPA423R](#) [VI-R5022-EXWW](#) [PSC128-7iR](#) [RPS8-350ATX-XE](#) [DAS1004812](#) [PQA30-D24-S24-DH](#) [vi-m13-cw-03](#) [VI-](#)
[LN2-EW](#) [VI-PJW01-CZY](#) [CK2540-9ERT](#) [AK-1615-7R](#) [700DNC40-CON-KIT-8G](#) [350DNC40-CON-KIT-9G](#) [088-101348-G](#) [VI-L52-EW](#)
[VI-L53-CV](#) [PQA30-D48-S12-TH](#) [VI-L50-IY](#) [VI-LC63-EV](#) [AM2D-051212DZ](#) [24IBX15-50-0ZG](#) [HZZ01204-G](#) [SPU02L-09](#) [SPU02M-09](#)
[SPU02N-09](#) [UNO-PS/350-900DC/24DC/60W](#) [QUINT4-BUFFER/24DC/20](#) [QUINT4-CAP/24DC/5/4KJ](#) [QUINT4-CAP/24DC/10/8KJ](#)