

## YAS1/D(0.6)1.2P (Z) 22——700V SSR

### 概述/General Features

- 过零和调相型/ Zero-cross, random trigger
- 负载电流最大为1.2A/Max load current 1.2A
- 高负载耐压700V/High load voltage 700V
- 符合RoHS/RoHS compliant
- UL E481250

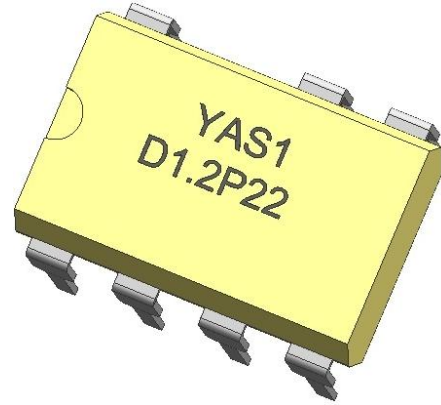

### 应用/Applications

➢ 家电产品（空调、冰箱、洗衣机微波炉等的风扇、加热、进出水开关等控制）

Home appliances (air conditioners, microwave ovens, washing machines, personal hygiene systems, refrigerators, fan heaters, inductive heating cooker, and water heaters, etc.)

➢ 工业控制 Industrial equipment market.

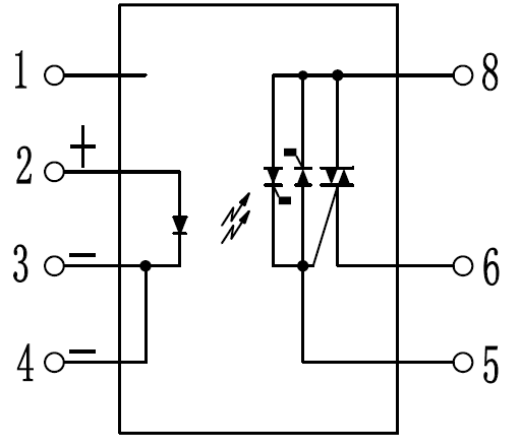

### 订货信息/Ordering Information

Part Number	Package	Marking
YAS1/D1.2P (Z) 22	DIP7	YAS1/D1.2P (Z) 22
YAS1/D0.6P (Z) 22	DIP7	YAS1/D0.6P (Z) 22

### 极限值/Absolute Maximum

(Ta=25)

特性参数/Parameter		符号/Symbol	测试条件/Test condition	最小值/Min.	典型值/Typ.	最大值/Max.	单位/Unit
输入端/Input	反向电流/LED reverse current	$I_R$	$V_R=5V$			1	$\mu A$
	正向电流/ LED forward current	$I_F$				50	mA
输出端/Output	断态泄漏电流/Output off-state leakage current	$I_R$	$V_b=700V$			1	$\mu A$
	阻断电压/ Repetitive peak OFF-state voltage	$V_{DRM}$				700	V
	额定电流/ ON-state RMS current	$I$	$I_F=10mA$			1200	mA
	额定电流/ ON-state RMS current (D0.6*22)	$I$	$I_F=10mA$			600	mA
	浪涌电流/ Surge current (D0.6*22)	$I$	50Hz, 1 cycle		6000		mA
	浪涌电流/ Surge current	$I$	50Hz, 1 cycle		12000		mA

## 电参数/Electrical parameter

(Ta=25℃)

特性参数/Parameter		符号 /Symbol	测试条件 /Test condition	最小 值 /Min.	典型值 /Typ.	最大值 /Max.	单位 /Unit
输入端 Input	正向电压 /LED forward voltage	$V_F$	$I_F=10mA$		1.2	1.3	V
	输入电流 / Input Current	$I$	$V_{in}=14.4$ $V_{d.c}, R_i=750\Omega$	10.0		19.8	mA
输出端 Output	额定电流 / ON-state RMS current	$I$	$I_F=10mA$			1200	mA
	额定电流 / ON-state RMS current (D0.6*22)	$I$	$I_F=10mA$			600	mA
	维持电流 /Holding current	$I_H$				50	mA
	电压指数上升率 /dv/dt	dv/dt	$V_{DM}=600V*1/\sqrt{2}$	200			V/ $\mu s$
耦合特性 Transfer characteristics	触发电流/Trigger current	$I_{FT}$	$V_o=6V, R_L=100\Omega$		4	8	mA
	导通电压降 /Output on-state voltage drop (D0.6*22)	V	$I_F=10mA, I_L=600mA$ $V_b=6V$		1.1	2.0	V
	导通电压降 /Output on-state voltage drop	V	$I_F=10mA, I_L=1200mA$ $V_b=6V$		1.1	2.0	V
	导通时间/ Turn on time	$t_{on}$	$I_F=10mA,$ $V_b=6V, R_L=100\Omega$		0.01	1	ms
	导通时间 /Turn on time (过零 zero-cross)	$t_{on}$	$I_F=10mA,$ $V_b=6V, R_L=100\Omega$			1+1/2cycle	ms
	关断时间 Turn off time	$t_{off}$				1+1/2cycle	ms
	介质电压 / Dielectric Strength*	$V_{ISO}$	$I_{off}\leq 0.5mA$	4000			$V_{rms}$
	工作温度 Operating temperature	T		-30		85	℃
储存温度 Store temperature			-40		125		

备注：1、介质电压超过 3000V 建议在油里测试。在测试前请务必确认输入端和输出端已经分别短路  
2、带“\*”参数为关键参数。

外形尺寸/Outline dimension :

1、DIP

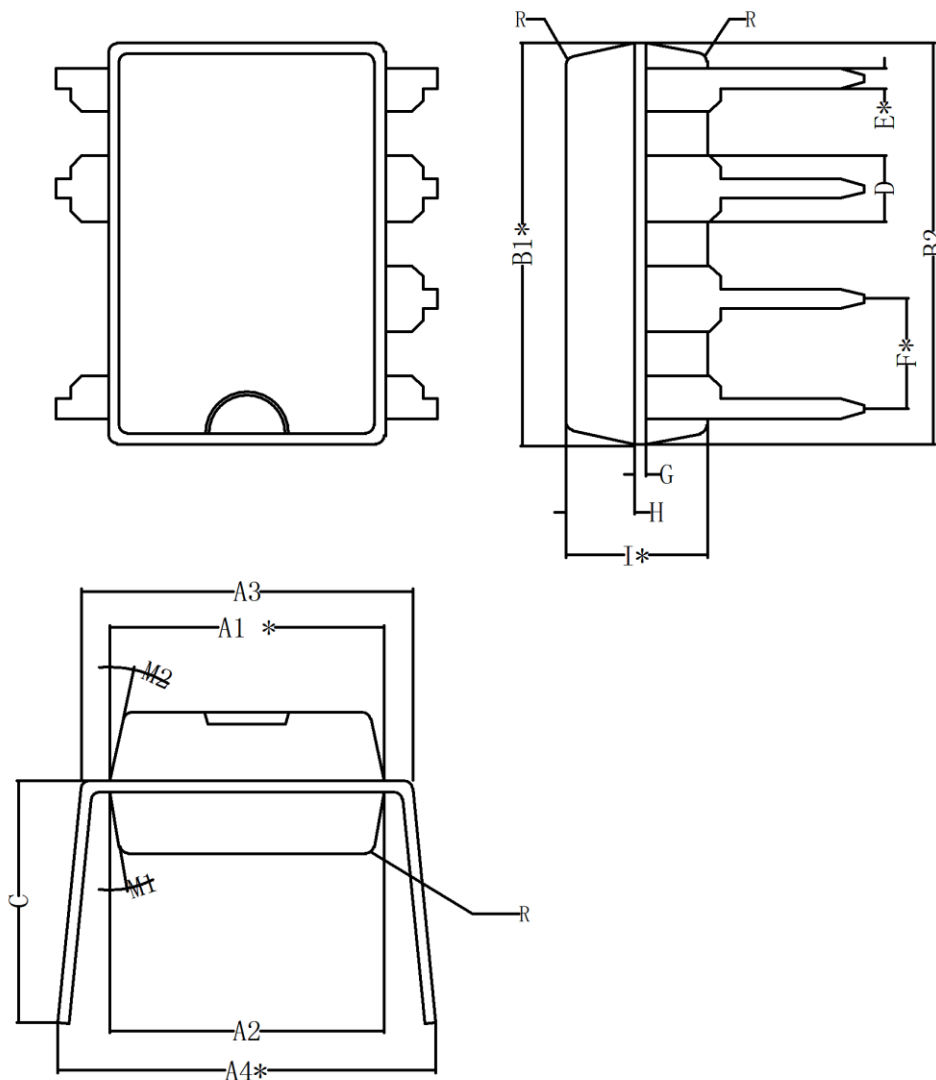

符号	最小	典型	最大	符号	最小	典型	最大
A1*	6.13	6.33	6.53	E*	0.34	0.42	0.50
A2	6.22	6.42	6.62	F*		2.54	
A3	7.32	7.62	7.92	G		0.25	
A4*	8.10	8.40	8.70	H	1.39	1.59	1.79
B1*	9.00	9.20	9.40	I*	3.07	3.27	3.47
B2	9.05	9.25	9.45	R		0.20	
C		5.57		M1		10°	
D		1.52		M2		12°	

注1: 未注公差请按±0.2;

注2: 带“\*”尺寸为关键尺寸。

## 2、SMD:

未注公差请按±0.2:

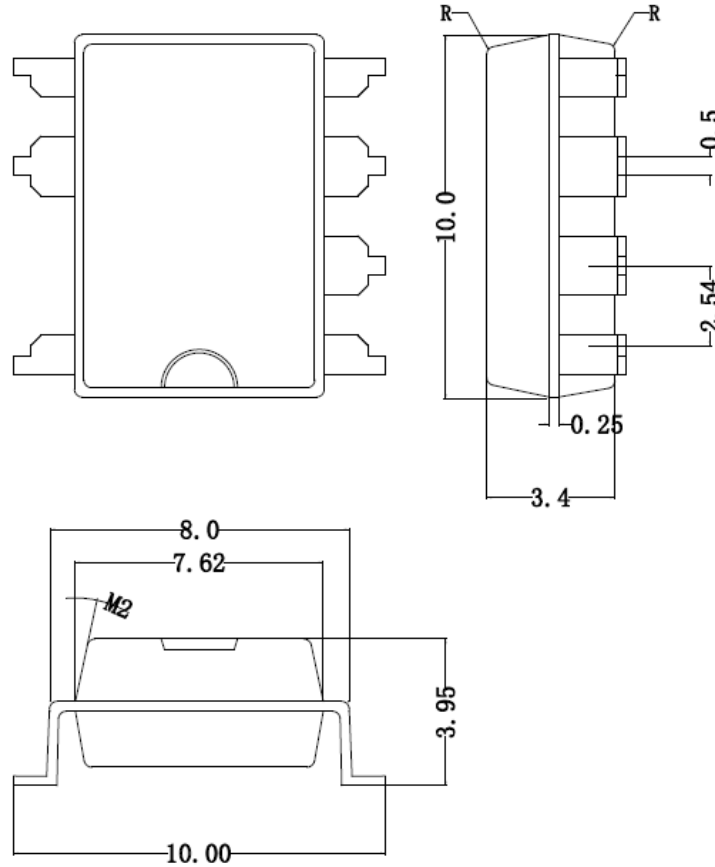

## 订货信息/Ordering Information :

订货信息/Ordering Information								
	Y	AS	1/	D	1.2	P	22	()
公司商标代号 Company symbol								
交流输出型 AC SSR								
封装 Package: 1: DIP8; 2: SIP4(单列直插)								
输入端电流型 Current driving: D 输入电压型 Voltage driving: 05D—5V;12D—12V;24D—24V;								
负载电流 Load current: 0.6—0.6A;1.2—1.2A;								
Z:过零 Zero-cross; P:调相 Non zero-cross								
负载电压 Load voltage: 22:220Vac;38:380Vac								
用户特殊编号 Special code								

### 安规要求/Safety and insulation ratings:

爬电距离 Creepage distance: 5.0mm, CTI  $\geq$ 275;

瞬时过电压 Highest allowable overvoltage 5000V;

再现峰值电压  $V_{IORM}$  769V;

局部放电 Partial discharge test voltage: 方法b Method b,  $V_{pd} = V_{IORM} \times 1.6$  1230V.

### 特性曲线/Characteristic Data:

负载电流与环境温度关系曲线 Load current vs. ambient temperature characteristics

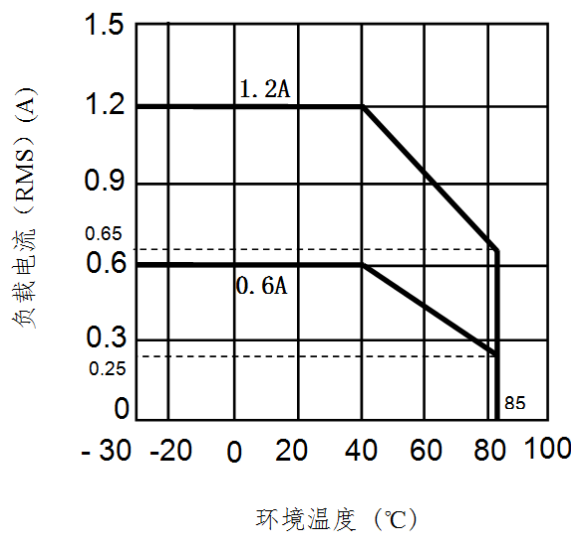

### 2. 导通压降—环境温度特性

On-state voltage drop vs. ambient temperature

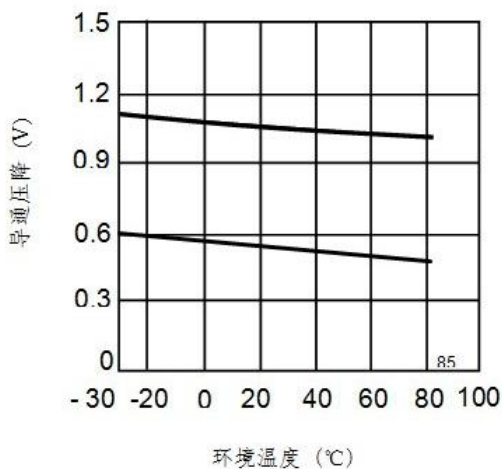

### 3. LED触发电流—环境温度特性

Trigger LED current vs. Ambient temperature

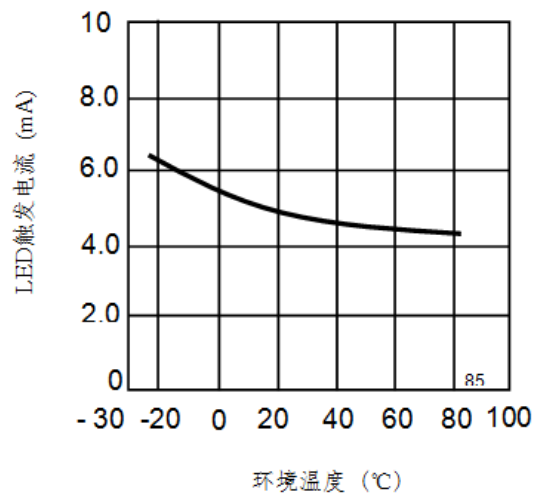

#### 4.LED 导通压降—环境温度特性

LED dropout voltage vs. Ambient temperature characteristics  
LED current: 10 to 50 mA

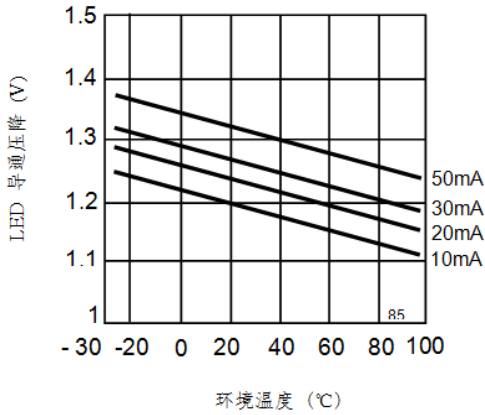

#### 5.导通时间—LED 电流特性

Turn on time vs. LED current

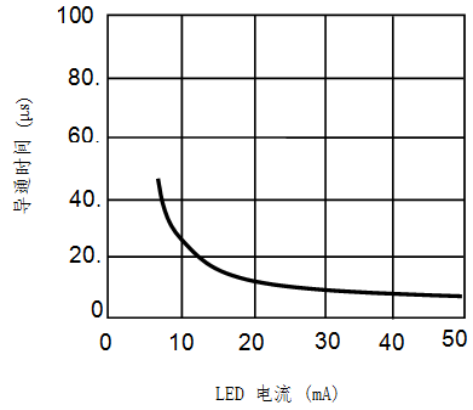

接通和关断时间关系, Turn on/Turn off time:

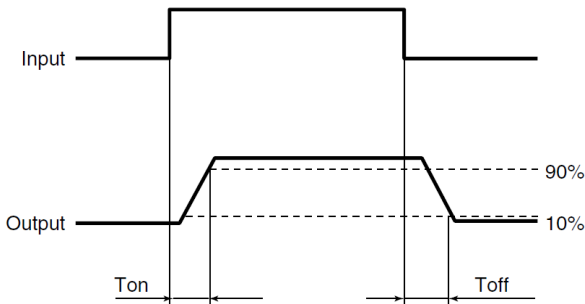

接线图/Wiring diagram:

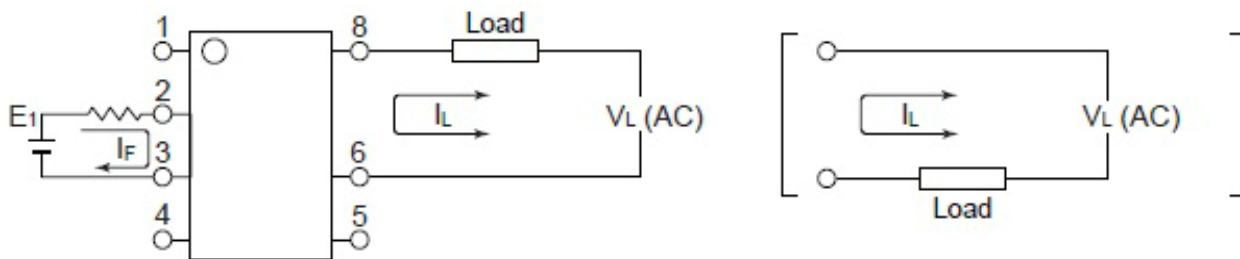

#### 注意事项 /Notes

- 工作环境温度超过 25°C 时请降额使用, 降额曲线参考附件。When ambient temperature is above 25°C, the load current must be reduced. (see Annexes, fig.1)
- 继电器接线时, 务必保证输入端极性的正确, 以免损坏继电器。Ensuring the polarity is correct when connecting the input lines, otherwise the wrong connection will damage the relay.

c) 由于 SSR 动作时间很短，输入端的噪声可能会引起 SSR 误动作，所以在输入端环境噪声较大时，应在输入端接 R/C 回路吸收噪声。

Since the operate time of the relay is extremely short, any noise to input terminal will cause malfunction of the SSR, So a RC circuit should be connected to input terminal to absorb the noise in the noisy condition.

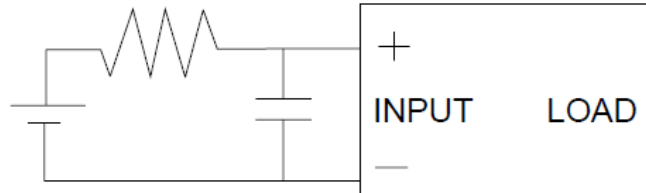

d) 推荐的使用电路，输出端的尖峰电压可能会引起 SSR 误动作，所以请在输出端应加 R/C 回路或压敏电子吸收尖峰电压，具体见下图：

Below shows a recommend circuit: Please add a RC circuit or varistor on the load side, as noise/surge could damage the unit or cause malfunctions.

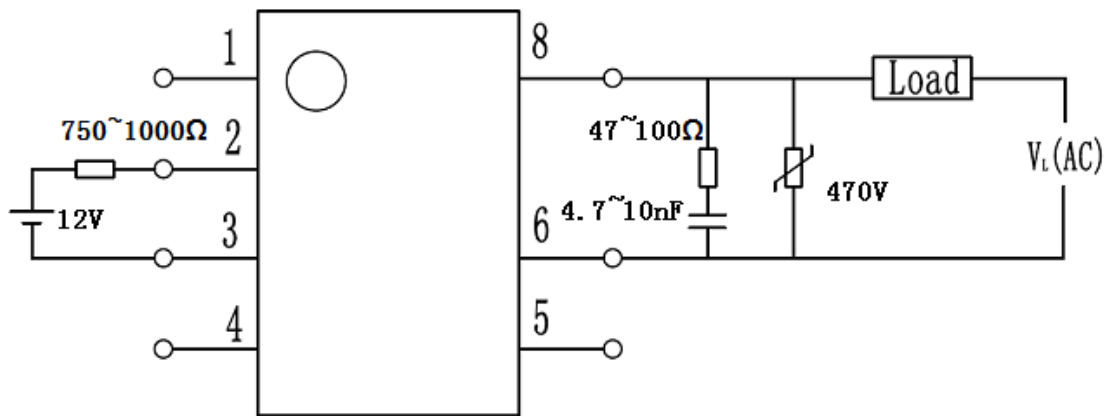

## 关于防静电对策/Cautions for Static Electricity

a. 使用电烙铁时，对电烙铁前端进行接地。(建议使用低电压用的电烙铁。) When using soldering irons, either use irons with low leakage current, or ground the tip of the soldering iron. (Use of low-voltage soldering irons is also recommended.)

b. 组装时使用的设备等也应正确地接地。Devices and equipment used in assembly should also be grounded.

## 关于焊接/soldering

继电器焊接，260 度情况下焊接时间不能超过 10 秒钟，350 度情况下焊接时间不能超过 5 秒钟。

Soldering must be completed within 10 seconds at 260°C or within 5 seconds at 350°C.

## **X-ON Electronics**

Largest Supplier of Electrical and Electronic Components

*Click to view similar products for [silicon billion manufacturer](#):*

Other Similar products are found below :

[YSM2/24D5P22](#) [YOM4/24D1006](#) [YAS2/D2P22](#) [YAS1/D0.6P22](#) [YDS1006D7](#) [YAS1/D1.2Z22](#) [YPN438S](#) [YOM3050D6](#) [Y2N655S](#)

[YAS1/D1.2P22](#) [YOM1006D6](#) [YAS2/D2Z22](#)