

YAS2/**D2P(Z)22——700V 2A SSR

概述/General Features

- 厚度3mm SSR/ Thickness3.0mm SSR
- 过零和调相型/ Zero-cross, random trigger
- 负载电流最大为2A/Max load current 2A
- 高负载耐压700V/High load voltage 700V
- 符合RoHS/RoHS compliant

应用/Applications

➢ 家电产品（空调、冰箱、洗衣机微波炉等的风扇、加热、进出水开关等控制）

Home appliances (air conditioners, microwave ovens, washing machines, personal hygiene systems, refrigerators, fan, heaters, inductive heating cooker, and water heaters, etc.)

➢ 工业控制

Industrial equipment market.

订货信息/Ordering Information

Part Number	Package	Marking
YAS2/**D2P(Z)22	SIP4	YAS2/**D2P(Z)22
YAS2/D2P(Z)22	SIP4	YAS2/D2P(Z)22

极限值/Absolute Maximum

特性参数/Parameter		符号/Symbol	测试条件/Test condition	最小值/Min.	典型值/Typ.	最大值/Max.	单位/Unit
输入端/Input	反向电流/LED reverse current	I_R	$V_i=5V$			10	μA
	正向电流/ LED forward current	I_F				50	mA
	输入电流/ Input current (**D2P22)	I_{in}	$V_{in}=V_{in}+20\%V$		15	18	mA
输出端/Output	阻断电压/ Repetitive peak OFF-state voltage	V_{DRM}				700	V
	额定电流/ ON-state RMS current	I	$I_F=10mA$			2	A
	浪涌电流/ Surge current	I	50Hz, 1 cycle		30		A

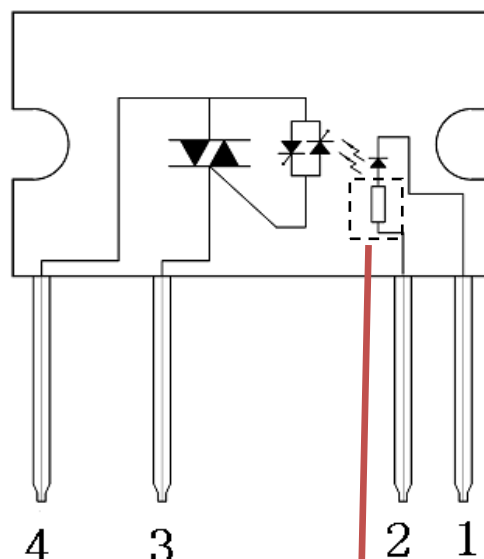
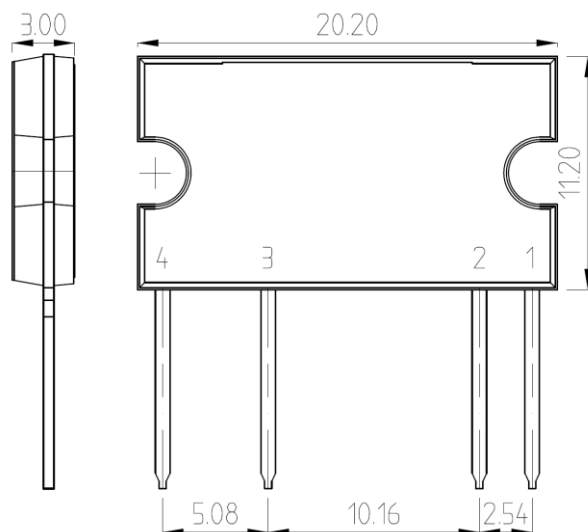

(环境温度/Ambient temperature: 25℃)

电参数/Electrical parameter

(环境温度/Ambient temperature: 25℃)

特性参数/Parameter		符号 /Symbol	测试条件/Test condition	最小值 /Min.	典型值 /Typ.	最大值 /Max.	单位 /Unit
输入端/Input	输入电流/Input current (**D2P22)	I_{in}	$V_{in}=V_{IN}(1+20\%)$		12	18	mA
	控制电压范围/Control voltage range (**D2P22)			$V_{IN}(1-20\%)$		$V_{IN}(1+20\%)$	V
	正向电压/LED forward Voltage drop	V_F	$I_F=10mA$		1.2	1.3	v
输出端/Output	额定电流/ ON-state RMS current	I	$I_F=10mA$			2000	mA
	断态漏电流/Output off-state leakage current	I_{DRM}	$V_o=700V$			3	μA
	电压指数上升率/ dv/dt	dv/dt	$V_{DRM}=600V*1/\sqrt{2}$	200			V/ μs
	负载电压/Load voltage	V_{ac}		48		264	V
	最小负载电流/Min. load current	I		100			mA
耦合特性 /Transfer characteristics	接通电压/Must operating voltage (**D2P22)	V_{on}				$V_{IN}(1-20\%)$	V
	LED 触发电流/trigger current	I_{FT}	$V_o=6V, R_L=100\Omega$		4 8		mA
	关断电压/ Must release voltage	V_{off}				1.2	V
	导通电压降/Output on-state voltage drop	V_T	$I_F=10mA, I_L=2A$ $V_o=6V$		1.2	1.5	V
	导通时间/Turn on time	t_{on}	$I_F=10mA,$ $V_o=6V, R_L=100\Omega$		0.01;	1	ms
	导通时间/Turn on time (**D2Z22, Zero-cross)	t_{on}	$I_F=10mA,$ $V_o=6V, R_L=100\Omega$		1+1/2 cycle	1	ms
	导通时间/Turn on time	t_{on}	$I_F=10mA,$ $V_o=6V, R_L=100\Omega$		0.01	1	ms
	关断时间/Turn off time	t_{off}				1+1/2cycle	ms
	绝缘电阻/Insulation Resistance	R_{iso}	500Vd. c			1000	M Ω
	介质电压/ I/O Dielectric Strength	V_{ISO}	$I_{off}\leq 0.5mA$		3000		V_{rms}
工作温度/Operating temperature	T			-30		85	℃
储存温度/Store temperature				-40		125	

安规要求/Safety and insulation ratings:

爬电距离 Creepage distance: 4.3mm, CTI ≥ 275 ;
 瞬时过电压 Highest allowable overvoltage 4000V;
 再现峰值电压 V_{IORM} 769V;
 局部放电 Partial discharge test voltage: 方法b Method b, $V_{pd} = V_{IORM} \times 1.6$ 1230V.

外形尺寸/Outline dimension : (mm)

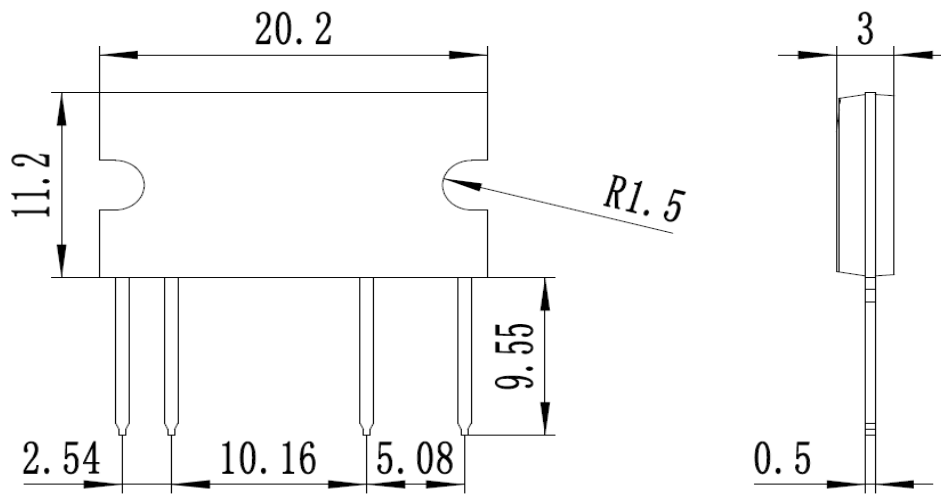

订货信息/Ordering Information :

订货信息/Ordering Information								
	Y	AS	1/	D	1.2	P	22	()
公司商标代号 Company symbol								
交流输出型 AC SSR								
封装 Package: 1: DIP8; 2: SIP4(单列直插)								
输入端电流型 Current driving: D								
输入电压型 Voltage driving: 05D—5V;12D—12V;24D—24V;								
负载电流 Load current: 1—1A;1.2—1.2A;2—2A;								
Z:过零 Zero-cross; P:调相 Non zero-cross								
负载电压 Load voltage: 22:220Vac;38:380Vac								
用户特殊编号 Special code								

特性曲线/Characteristic Data:

负载电流与环境温度关系曲线 Load current vs. ambient temperature characteristics

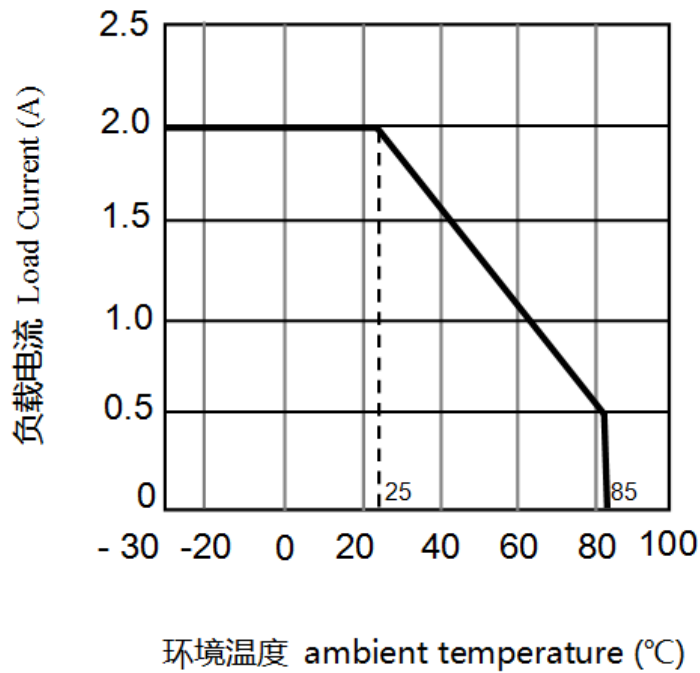

2. 导通压降—环境温度特性

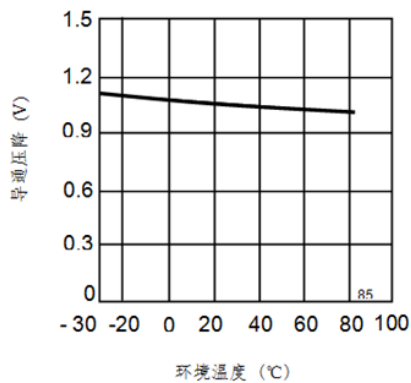

4. LED 导通压降—环境温度特性

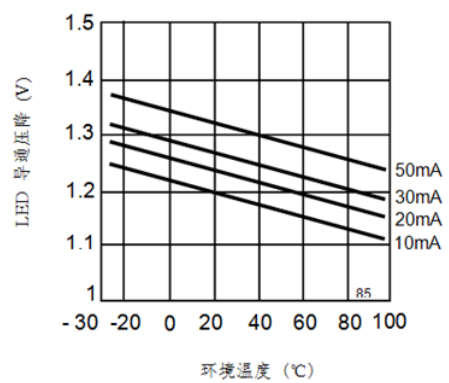

5. 导通时间—LED 电流特性

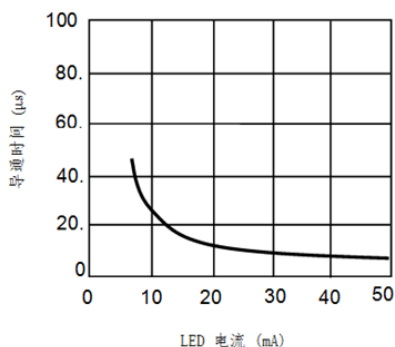

6. 重复峰值关断电流—负载电压

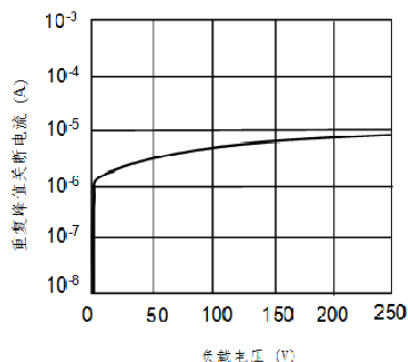

* 接通和关断时间关系, Turn on/Turn off time

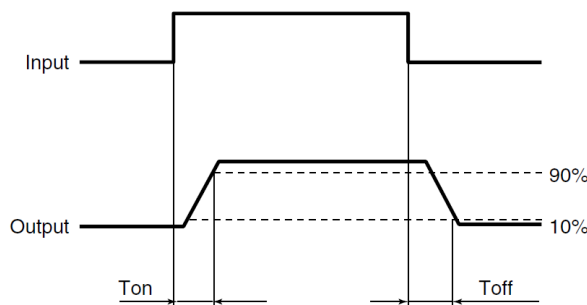

注意事项 /Notes

- a) 工作环境温度超过 25°C 时请降额使用, 降额曲线参考附件。When ambient temperature is above 25°C, the load current must be reduced. (see Annexes, fig.1)
- b) 继电器接线时, 务必保证输入端极性的正确, 以免损坏继电器。Ensuring the polarity is correct when connecting the input lines, otherwise the wrong connection will damage the relay.
- c) 由于 SSR 动作时间很短, 输入端的噪声可能会引起 SSR 误动作, 所以在输入端环境噪声较大时, 应在输入端接 R/C 回路吸收噪声。
Since the operate time of the relay is extremely short, any noise to input terminal will cause malfunction of the SSR, So a RC circuit should be connected to input terminal to absorb the noise in the noisy condition.

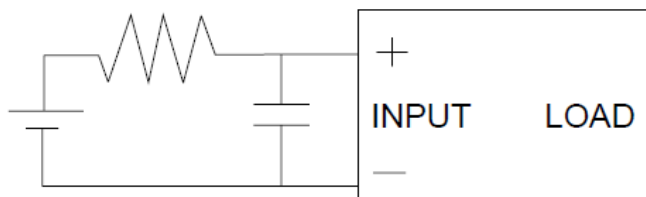

d) 推荐的使用电路，输出端的尖峰电压可能会引起 SSR 误动作，所以请在输出端应加 R/C 回路或压敏电子吸收尖峰电压，具体见下图：

Below shows a recommend circuit: Please add a RC circuit or varistor on the load side, as noise/surge could damage the unit or cause malfunctions.

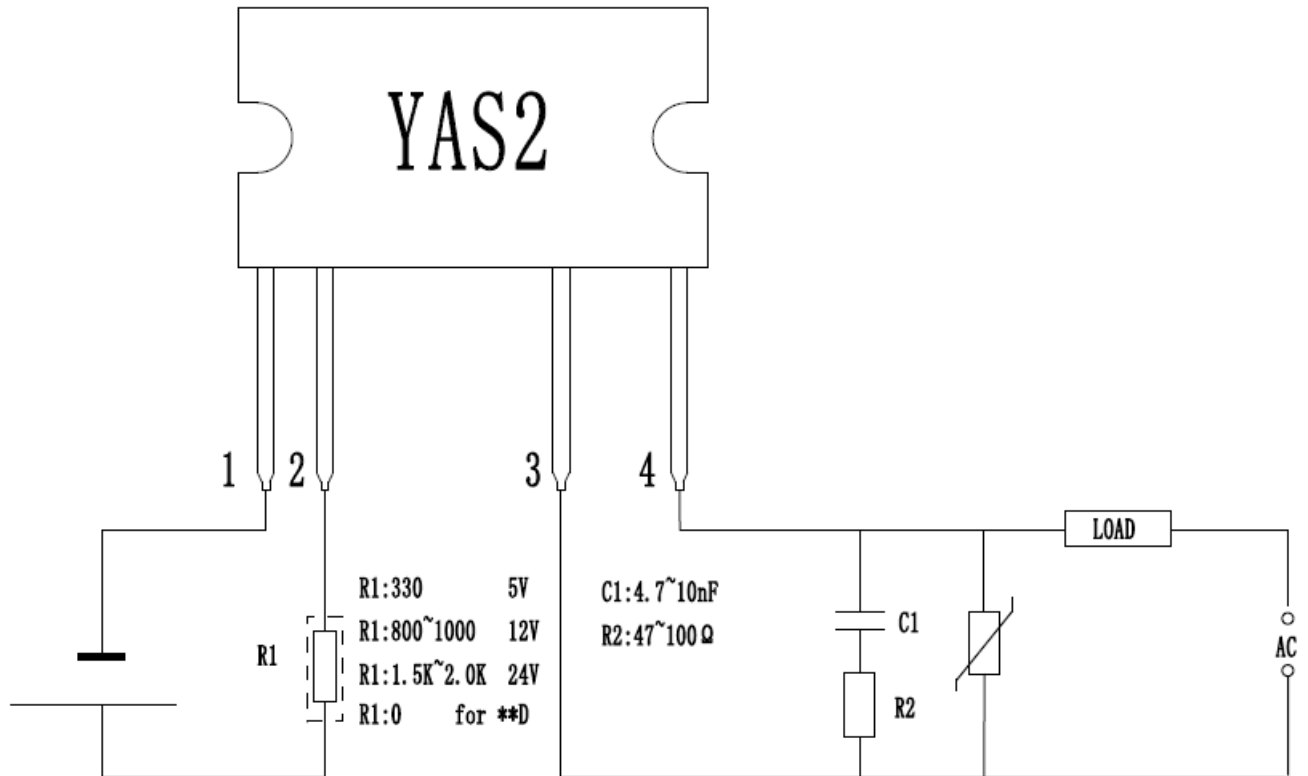

关于防静电对策/Cautions for Static Electricity

- 使用电烙铁时，对电烙铁前端进行接地。(建议使用低电压用的电烙铁。) When using soldering irons, either use irons with low leakage current, or ground the tip of the soldering iron. (Use of low-voltage soldering irons is also recommended.)
- 组装时使用的设备等也应正确地接地。Devices and equipment used in assembly should also be grounded.

关于焊接/soldering

继电器焊接，260 度情况下焊接时间不能超过 10 秒钟，350 度情况下焊接时间不能超过 5 秒钟。
Soldering must be completed within 10 seconds at 260°C or within 5 seconds at 350°C.

X-ON Electronics

Largest Supplier of Electrical and Electronic Components

Click to view similar products for [silicon billion](#) manufacturer:

Other Similar products are found below :

[YSM2/24D5P22](#) [YOM4/24D1006](#) [YAS2/D2P22](#) [YAS1/D0.6P22](#) [YDS1006D7](#) [YAS1/D1.2Z22](#) [YPN438S](#) [YOM3050D6](#) [Y2N655S](#)

[YAS1/D1.2P22](#) [YOM1006D6](#) [YAS2/D2Z22](#)