

YPN 438S——40V 10A N&P-Channel Power MOSFET (2 IN 1)

General Features

- Proprietary New Trench Technology
- Ultra-low Miller Charge
- N MOS RDS(ON),typ.=18mΩ@V_{GS}=10V
- P MOS RDS(ON),typ.=30mΩ@V_{GS}=10V
- Low Gate Charge Minimize Switching Loss
- Fast Recovery Body Diode

Applications

- High efficiency DC/DC Converters
- Synchronous Rectification
- Motor Drive

Ordering Information

Part Number	Package	Marking
YPN 438S	SOP-8	438

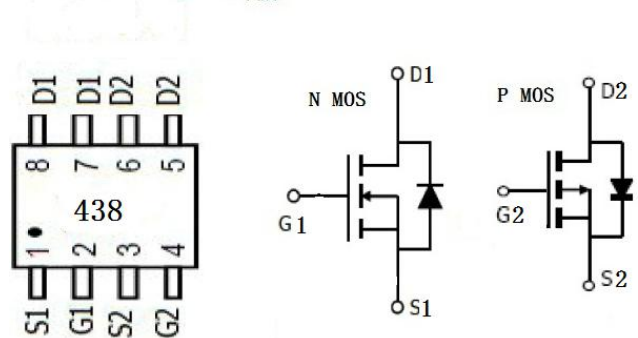

Absolute Maximum Ratings

Absolute Maximum Ratings		T _A =25°C unless otherwise noted			
		Symbol	Maximum		Units
Parameter		N MOS	P MOS		
Drain-Source Voltage	V _{DS}	+40	-40	V	
Gate-Source Voltage	V _{GS}	±20 V	±20 V	V	
Continuous Drain Current	I _D	T _A =25°C	12.2	-10	A
		T _A =70°C	8.5	-8	
Pulsed Drain Current	I _{DM}	35	-30		
Maximum Power Dissipation		2.5	2.8	W	
Operating Junction and Storage Temperature Range	T _J , T _{STG}	-55 to 150		°C	

Caution: Stresses greater than those listed in the "Absolute Maximum Ratings" may cause permanent damage to the device

Thermal Characteristics

Symbol	Parameter	Value	Unit
R _{θJC}	Thermal Resistance, Junction-to-Case	4.0	°C/W
R _{θJA}	Thermal Resistance, Junction-to-Ambient	42	

Electrical Characteristics

Symbol	Parameter	Conditions	Min	Typ	Max	Units
Off Characteristics						
BV_{DSS}	Drain-Source Breakdown Voltage	$I_D = \pm 250mA, V_{GS} = 0V$	± 40			V
I_{DSS}	Zero Gate Voltage Drain Current	$V_{DS} = \pm 40V, V_{GS} = 0V$			1	μA
I_{GSS}	Gate-Body leakage current	$V_{DS} = 0V, V_{GS} = \pm 20V$			± 100	nA
On Characteristics (Note 3)						
$V_{GS(th)}$	Gate Threshold Voltage	NMOS: $V_{DS} = V_{GS}, I_D = 250mA$	1	1.5	2.5	V
		PMOS: $V_{DS} = V_{GS}, I_D = -250mA$	-1.1	-1.7	-2.5	
$R_{DS(ON)}$	Static Drain-Source On-Resistance	NMOS: $V_{GS} = 10V, I_D = 10A$		15	18	$m\Omega$
		NMOS: $V_{GS} = 4.5V, I_D = 8A$		22	35	
		PMOS: $V_{GS} = -10V, I_D = -7.2A$		27	32	$m\Omega$
		PMOS: $V_{GS} = -4.5V, I_D = -5.6A$		32	38	
g_{FS}	Forward Transconductance	NMOS: $V_{DS} = 5V, I_D = 8A$	13			S
		PMOS: $V_{DS} = -5V, I_D = -5A$	20			
Drain-Source Diode Characteristics						
V_{SD}	Diode Forward Voltage _(Note 3)	NMOS: $V_{GS} = 0V, I_S = 8A$			1.2	V
		PMOS: $V_{GS} = 0V, I_S = -6A$				
I_S	Maximum Body-Diode Continuous Current _(Note 2)	NMOS			10	A
		PMOS			-6.2	
t_{rr}	Body Diode Reverse Recovery Time	NMOS: $T_J = 25^\circ C, I_F = 10A, di/dt = 100A/\mu s$ _(Note3)		35		ns
		PMOS: $T_J = 25^\circ C, I_F = -7A, di/dt = 100A/\mu s$ _(Note3)		60		
Dynamic Characteristics (Note4)						
C_{iss}	Input Capacitance	NMOS		500		pf
C_{oss}	Output Capacitance	$V_{DS} = 20V, V_{GS} = 0V, F = 1.0MHz$		60		
C_{rss}	Reverse Transfer Capacitance			25		
C_{iss}	Input Capacitance	PMOS		1750		
C_{oss}	Output Capacitance	$V_{DS} = -20V, V_{GS} = 0V, F = 1.0MHz$		215		
C_{rss}	Reverse Transfer Capacitance			180		

Symbol	Parameter	Conditions	Min	Typ	Max	Units
Switching Characteristics (Note 4)						
Q_g	Total Gate Charge	NMOS : $V_{GS}=10V$, $V_{DS}=20V$, $I_D=8A$		14		nC
Q_{gs}	Gate Source Charge			2.9		
Q_{gd}	Gate Drain Charge			5.2		
Q_g	Total Gate Charge	PMOS : $V_{GS}=-10V$, $V_{DS}=-20V$, $I_D=-5A$		24		nC
Q_{gs}	Gate Source Charge			3.5		
Q_{gd}	Gate Drain Charge			6		
$t_{d(on)}$	Turn-On Delay time	NMOS: $V_{DD}=20V, I_D=2A, R_L=6.7\Omega$ $V_{GS}=10V, R_G=3\Omega$		5		ns
t_r	Turn-On Rise Time			2.6		
$t_{d(off)}$	Turn-Off Delay Time			16.1		
t_f	Turn-Off Fall Time			2.3		
$t_{d(on)}$	Turn-On Delay Time	PMOS: $V_{DD}=-20V, I_D=-2A, R_L=2\Omega$, $V_{GS}=-10V, R_{GEN}=3\Omega$		9		ns
t_r	Turn-On Rise Time			8		
$t_{d(off)}$	Turn-Off Delay Time			28		
t_f	Turn-Off Fall Time			10		

Notes:

1. Repetitive Rating: Pulse width limited by maximum junction temperature.
2. Surface Mounted on FR4 Board, $t \leq 10$ sec.
3. Pulse Test: Pulse Width $\leq 300\mu s$, Duty Cycle $\leq 2\%$.
4. Guaranteed by design, not subject to production

Typical Electrical and Thermal Characteristics (Curves):P MOS

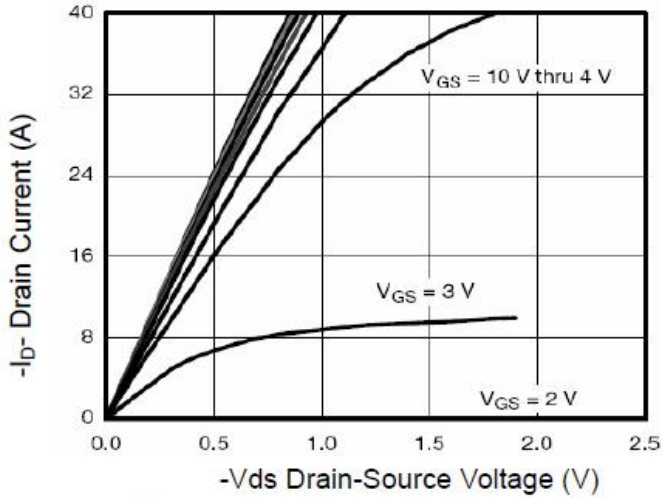

Figure 1 Output Characteristics

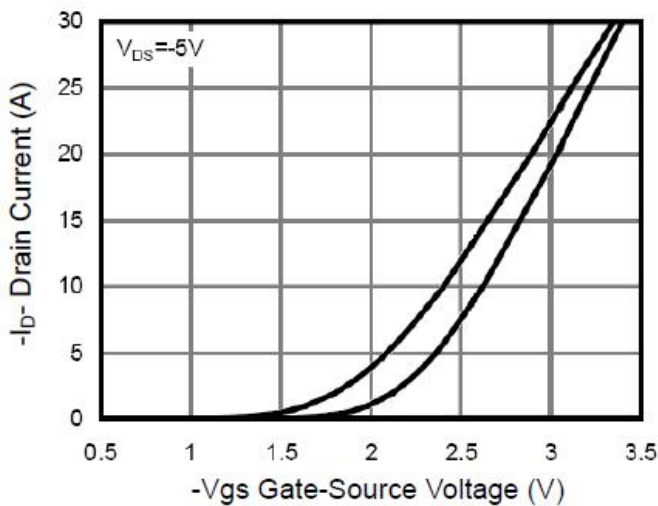

Figure 2 Transfer Characteristics

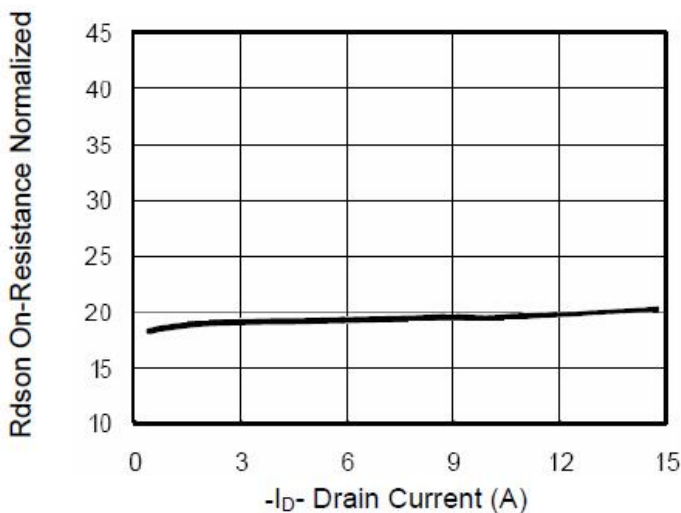

Figure 3 Rdson- Drain Current

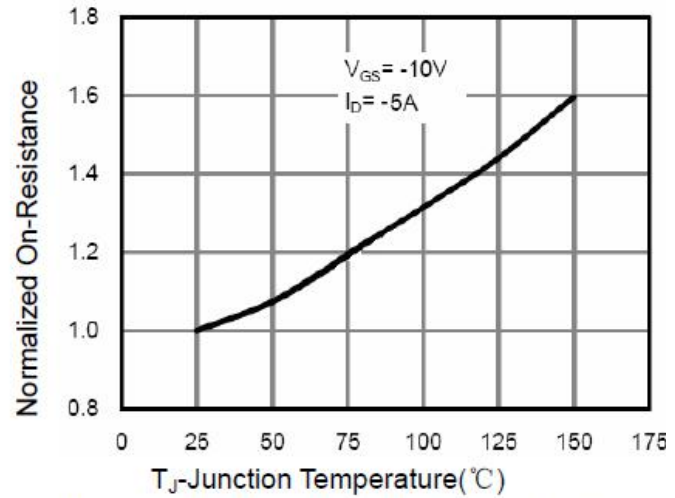

Figure 4 Rdson-Junction Temperature

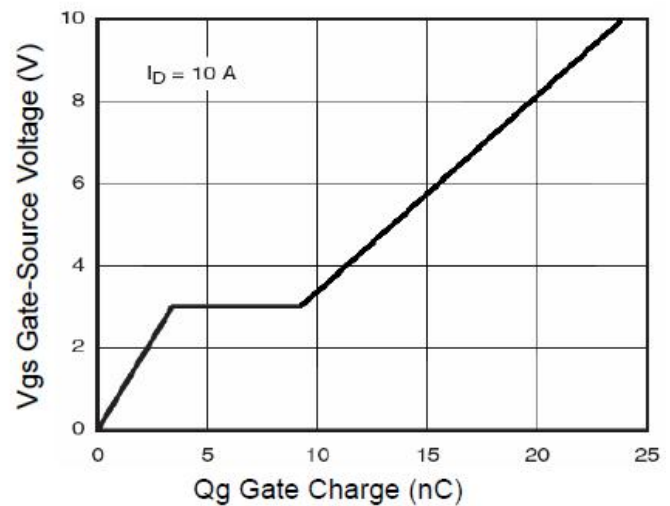

Figure 5 Gate Charge

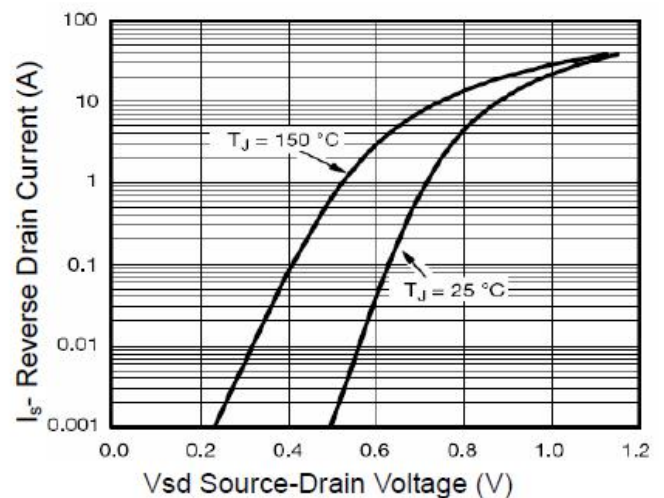

Figure 6 Source- Drain Diode Forward

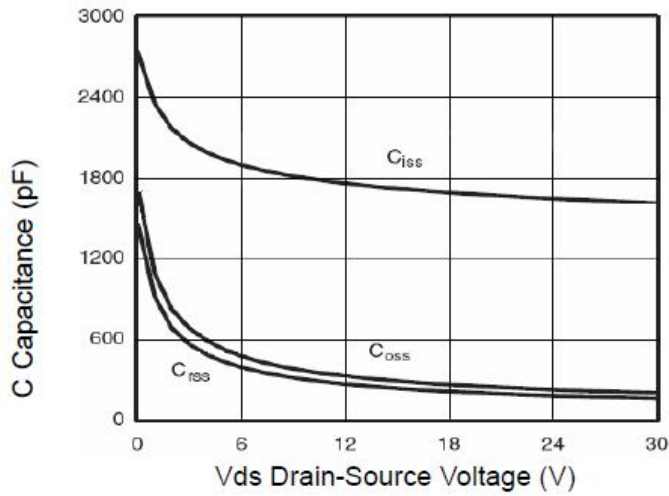

Figure 7 Capacitance vs Vds

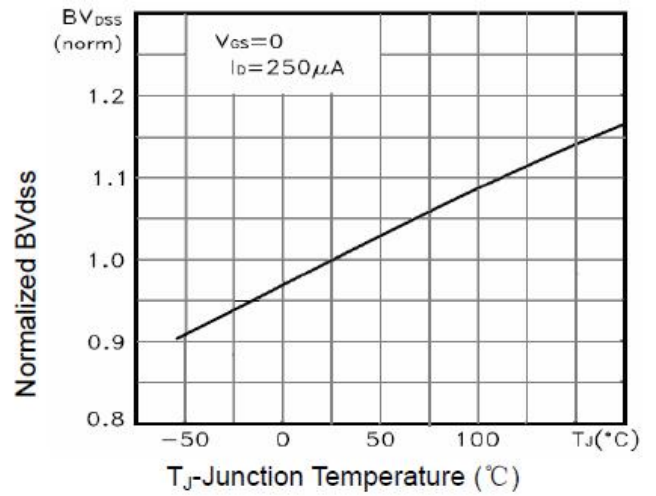

Figure 9 BV_{DSS} vs Junction Temperature

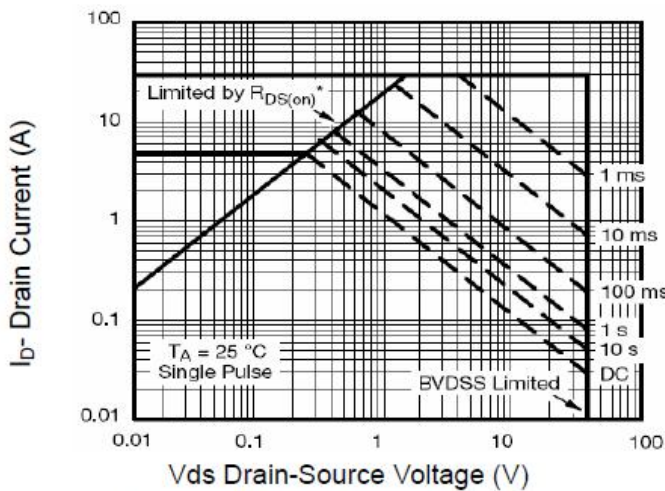

Figure 8 Safe Operation Area

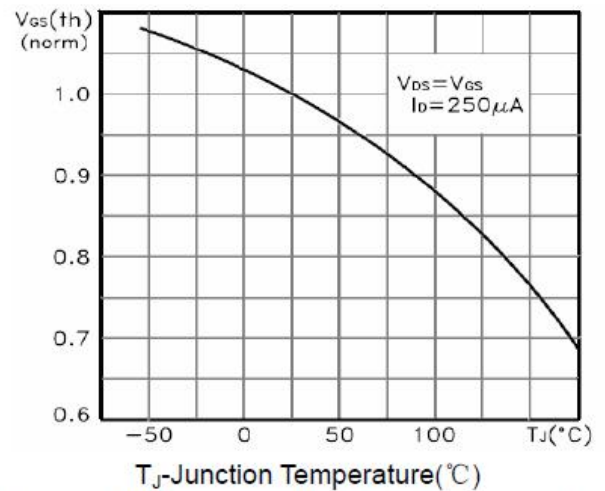

Figure 10 $V_{GS(th)}$ vs Junction Temperature

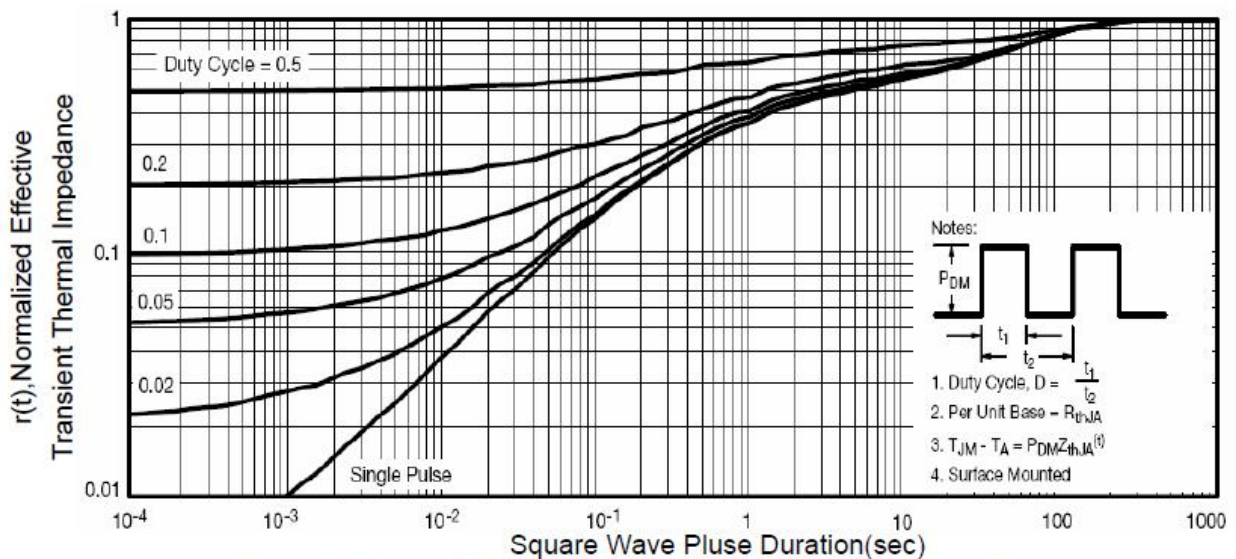

Figure 11 Normalized Maximum Transient Thermal Impedance

Typical Electrical and Thermal Characteristics (Curves):N MOS

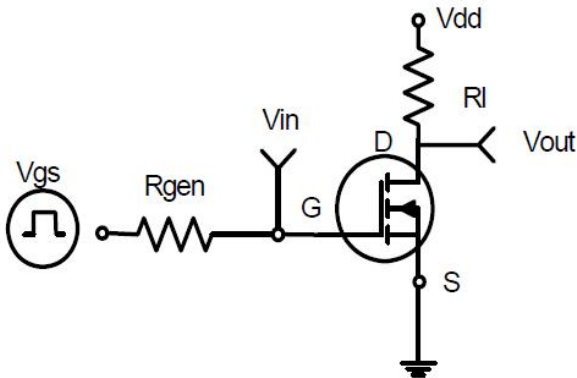

Figure 1: Switching Test Circuit

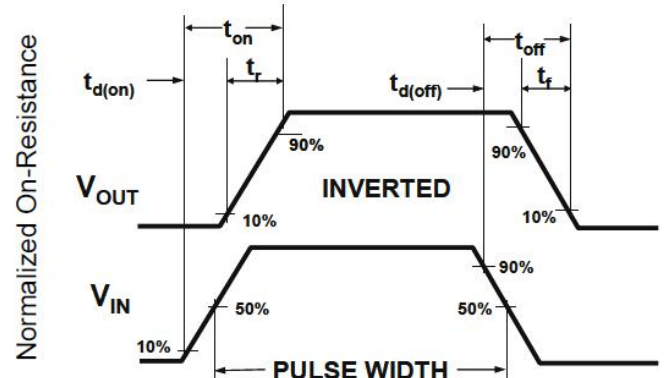

Figure 2: Switching Waveforms

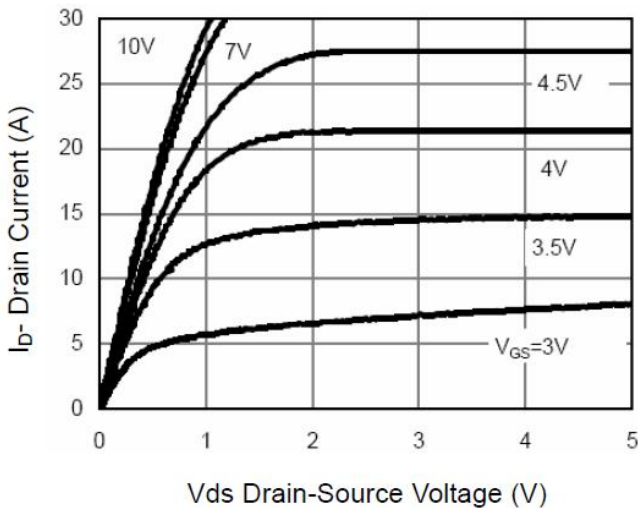

Figure 3 Output Characteristics

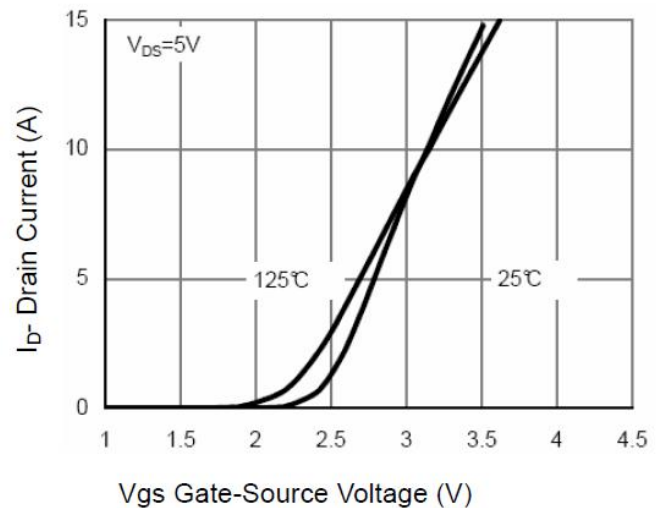

Figure 4 Transfer Characteristics

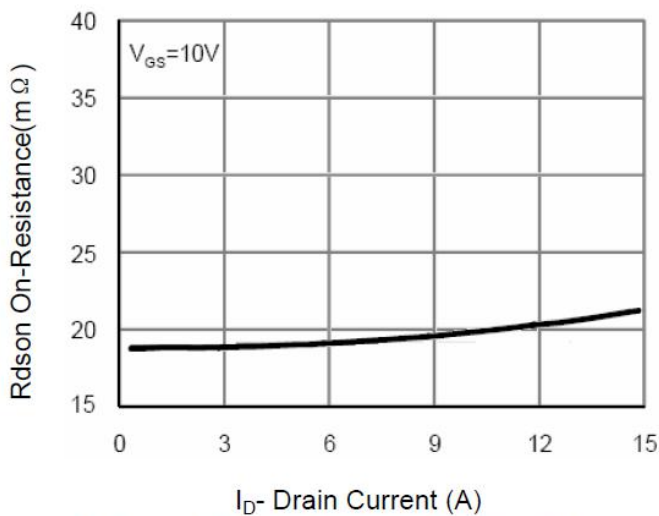

Figure 5 Drain-Source On-Resistance

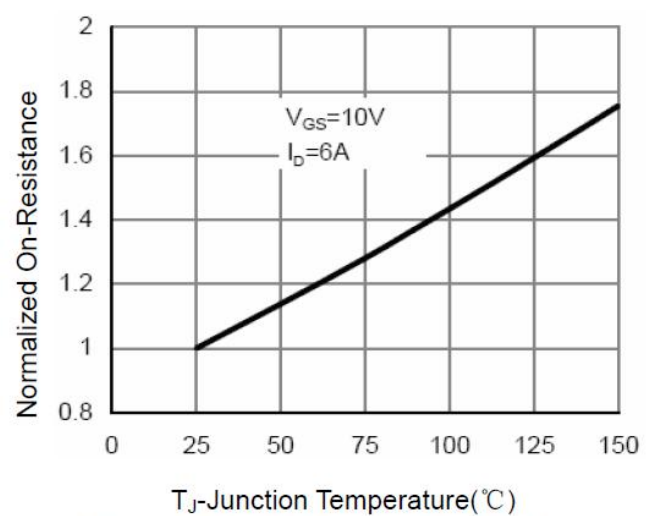

Figure 6 Drain-Source On-Resistance

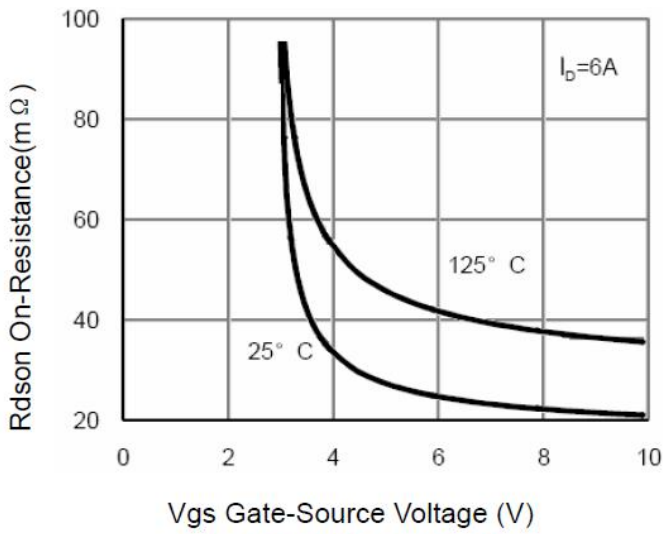

Figure 7 Rdson vs Vgs

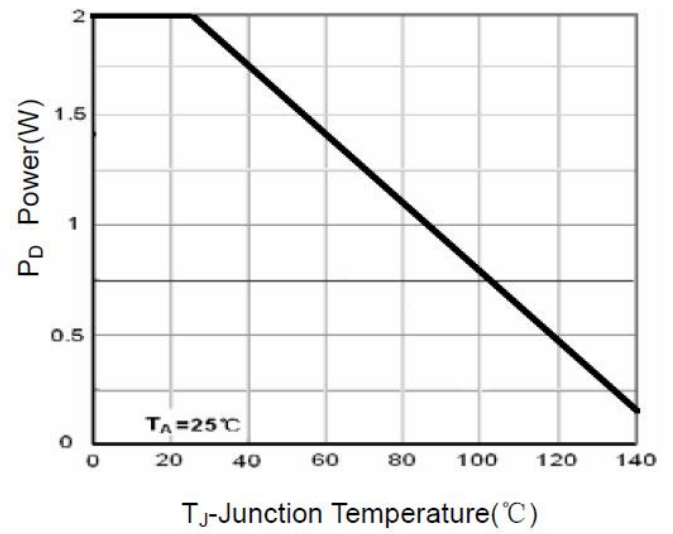

Figure 8 Power Dissipation

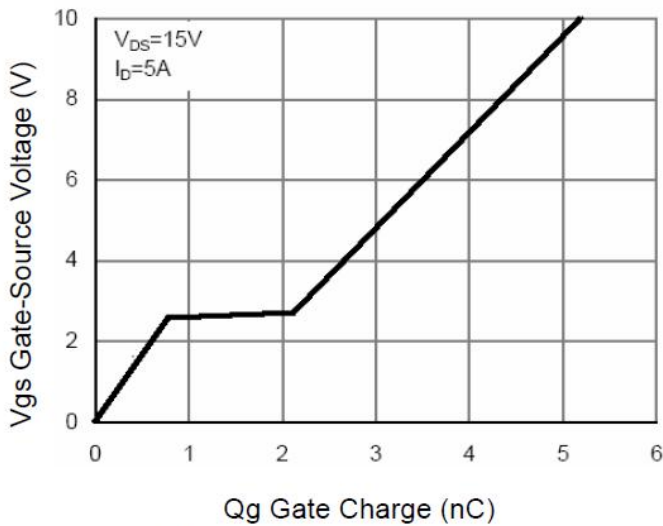

Figure 9 Gate Charge

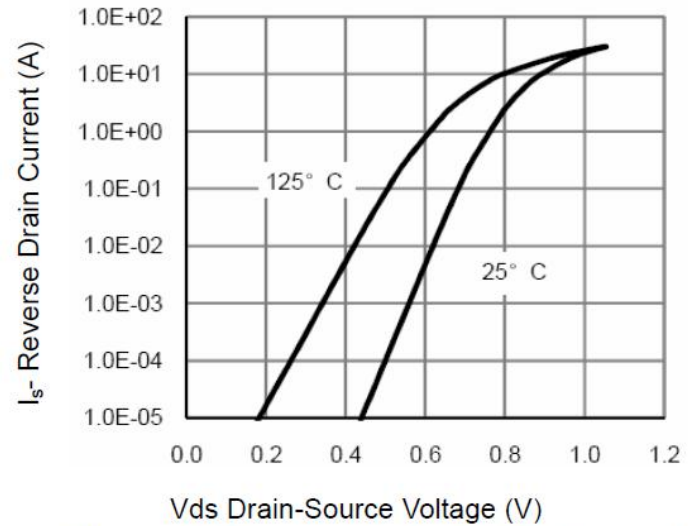

Figure 10 Source- Drain Diode Forward

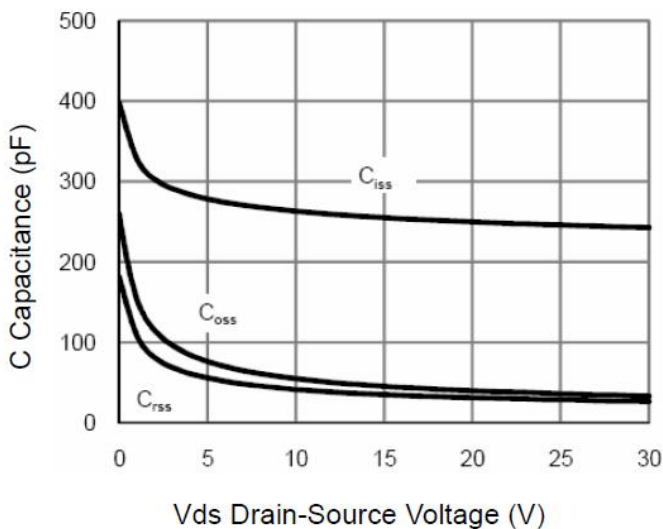

Figure 11 Capacitance vs Vds

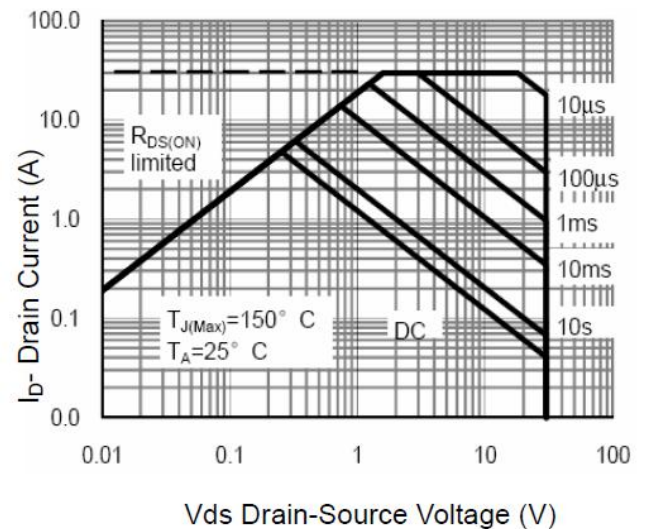

Figure 12 Safe Operation Area

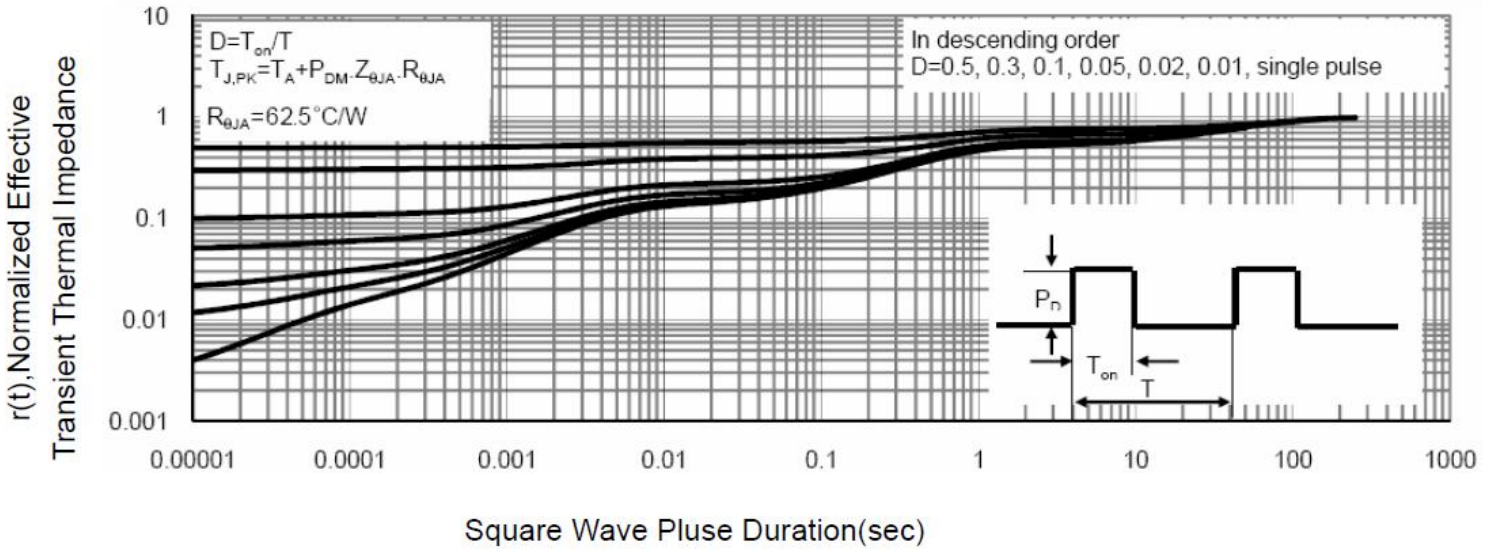
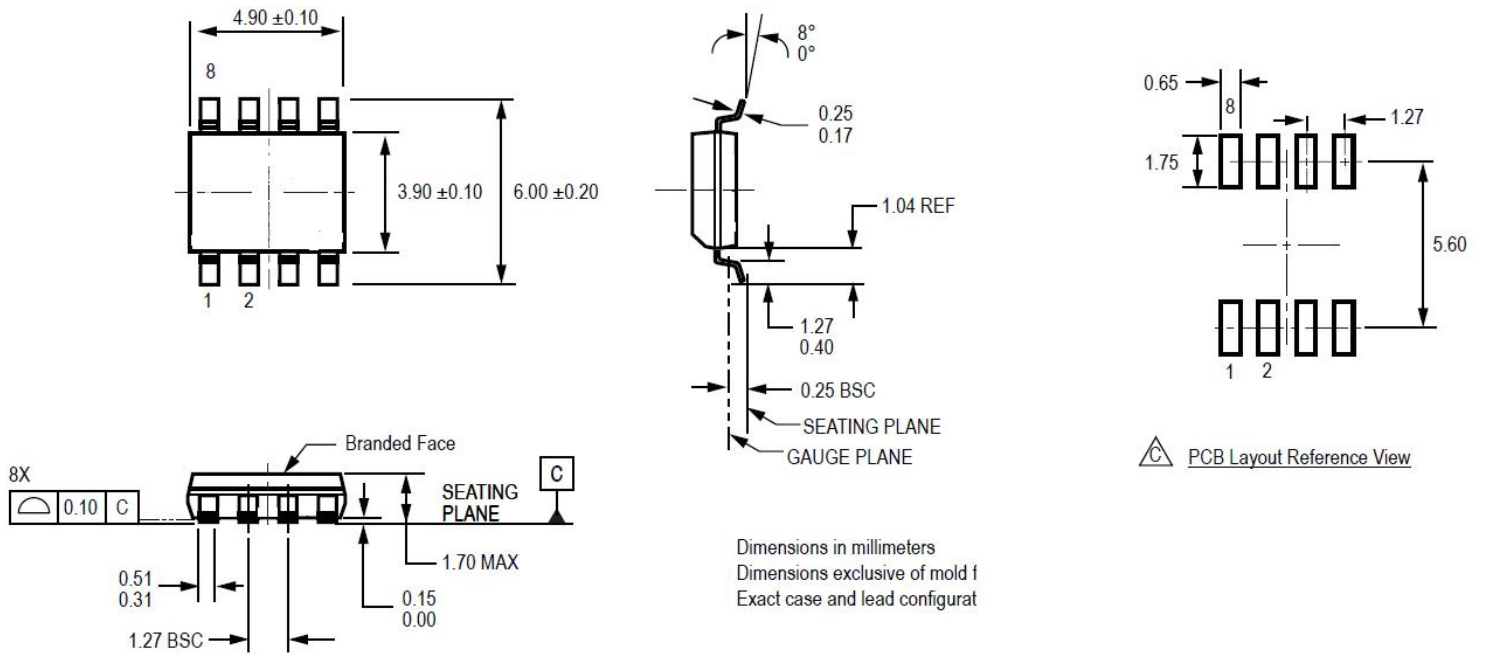

Figure 13 Normalized Maximum Transient Thermal Impedance

Order information:

Order information							
	Y	2	N/	6	55	S	()
公司商标代号 Company symbol							
1: NIL ,2:2 MOS							
P: PMOS, N:N MOS							
BVDSS: 6—60V;10—100V;20—200V; 35—350V; 40—400V							
RDS(on) : 55—55mΩ ;38—38mΩ ; 16—16mΩ							
D:DIP;S:SOP							
Special code							

Dimension and PCB layout :



X-ON Electronics

Largest Supplier of Electrical and Electronic Components

Click to view similar products for [MOSFET](#) category:

Click to view products by [Silicon Billion](#) manufacturer:

Other Similar products are found below :

[614233C](#) [648584F](#) [MCH3443-TL-E](#) [MCH6422-TL-E](#) [FDPF9N50NZ](#) [FW216A-TL-2W](#) [FW231A-TL-E](#) [APT5010JVR](#) [NTNS3A92PZT5G](#)
[IRF100S201](#) [JANTX2N5237](#) [2SK2464-TL-E](#) [2SK3818-DL-E](#) [FCA20N60_F109](#) [FDZ595PZ](#) [STD6600NT4G](#) [FSS804-TL-E](#) [2SJ277-DL-E](#)
[2SK1691-DL-E](#) [2SK2545\(Q,T\)](#) [D2294UK](#) [405094E](#) [423220D](#) [MCH6646-TL-E](#) [TPCC8103,L1Q\(CM](#) [367-8430-0972-503](#) [VN1206L](#)
[424134F](#) [026935X](#) [051075F](#) [SBVS138LT1G](#) [614234A](#) [715780A](#) [NTNS3166NZT5G](#) [751625C](#) [873612G](#) [IRF7380TRHR](#)
[IPS70R2K0CEAKMA1](#) [RJK60S3DPP-E0#T2](#) [RJK60S5DPK-M0#T0](#) [APT5010JVFR](#) [APT12031JFLL](#) [APT12040JVR](#) [DMN3404LQ-7](#)
[NTE6400](#) [JANTX2N6796U](#) [JANTX2N6784U](#) [JANTXV2N5416U4](#) [SQM110N05-06L-GE3](#) [SIHF35N60E-GE3](#)