



Zentri AMW004 Data Sheet



Disclaimer

While the information provided in this document is believed to be accurate, it is under development and Zentri reserves the right to make changes without further notice to the product described herein to improve reliability, function, or design, and makes no guarantee or warranty concerning the accuracy of said information, nor shall it be responsible for any loss or damage of whatever nature resulting from the use of, or reliance upon, such information. Zentri makes no warranties of any kind, whether express, implied or arising by custom or course of trade or performance, and specifically disclaims the implied warranties of title, non-infringement, merchantability, or fitness for a particular purpose.

No part of this document may be copied, reproduced, stored in a retrieval system, or transmitted, in any form or by any means, electronic, mechanical, photographic, or otherwise, or used as the basis for manufacture or sale of any items without the prior written consent of Zentri.

Trademarks

Zentri and the Zentri logo are trademarks of Zentri. Other trademarks in this document belong to their respective owners.

© 2014-2017 Zentri.

All rights reserved.

Document Number: ADS-MW004-106R

Release Date: August 29, 2017

Contact

<https://www.silabs.com/about-us/contact-us>

About this Data Sheet

This document provides information on the AMW004 embedded Wi-Fi networking solution from Zentri. Specifications for the I/O and peripherals are taken from the MCU datasheet. Specifications for the WLAN subsystem were compiled from measured data unless otherwise noted.

Organization

This data sheet is organized into the following sections:

General Features

Firmware Features

- 1 General Description
- 2 Block Diagram
- 3 Electrical Specifications
- 4 WLAN RF Specifications
- 5 Pinout and Signal Descriptions
- 6 Design Guidelines
- 7 Regulatory Certification
- 8 Packaging, Handling & Storage, RoHS
- 9 Ordering Information
- 10 Product Number Syntax
- 11 Revision History & Glossary
- 12 References

AMW004 Datasheet

Embedded Wi-Fi Networking Solution

General Features

- Self-contained low-power Wi-Fi networking module with onboard microcontroller and antenna (PCB trace and uFL).
- Integrated SPI-serial flash for software upgrades

Wi-Fi

- Cypress CYW43362 single band 2.4GHz IEEE 802.11b/g/n 1x1 Wi-Fi transceiver
- Includes support for all Wi-Fi security modes including Open, WEP, WPA, and WPA2-PSK

Microprocessor

- ARM 32-bit Cortex™-M4 CPU
- Up to 22 Peripheral DMA controller channels
- Ultra Low Power sleep, wait and backup modes
- 128-bit unique ID

Interfaces*

- A/D converters: 10 channel input, 12-bit resolution, 1MSPS with gain control and auto calibration
- D/A converter: 1 channel x 12-bit, 1 MSPS
- UART: 2 x 4-wire for host comms & debug
- SPI: 1 x SPI-Master for peripheral comms
- GPIO: Up to 29 GPIOs (overlaid with peripherals)
- PWM: Up to 12 PWM outputs
- Wake-up : 12 External wake inputs for ultra-low power operation
- External Wi-Fi antenna option

**Some interfaces share module pins*

Operational & Radio

- Single operating voltage : 3.3V (typical)
- Operational Temperature Range: -30°C to +85°C
- Size : 31.8 x 17.8 x 2.7 mm (1.25" x 0.70" x 0.11")
- Weight : 0.07 oz (2 g)
- Current consumption @ 25°C
 - Backup : 1.85 μ A, <300 μ s wakeup
 - Wait : 28 μ A, <100 μ s wakeup, RAM retention
 - Wi-Fi Powersave : 0.77 mA
 - UDP receive (1 Mbit/s) : 6.9 mA
 - UDP transmit (1 Mbit/s) : 12.5 mA
 - Active receive (100% duty cycle) : 87.8 mA

- Active transmit (100% duty cycle) : 348.8 mA

- Maximum RF transmit power

- 802.11b/g : +18.5 dBm
- 802.11n : +13.5 dBm

- Minimum Receive sensitivity

- 802.11b/g : -94 dBm
- 802.11n : -86 dBm

- Sustained TCP throughput

- UART : >10 Mbit/s

Applications

- Industrial, M2M and Home Automation
 - Environmental monitoring
 - Energy monitoring
 - Wireless sensing, remote data logging
 - HVAC, power, light, & thermostat control
 - Appliance control
- Security
 - Cameras, Doors/Window monitoring
 - Alarms, Smoke Detectors
 - Door and entry control
- Health & Fitness
 - Fitness Equipment
 - Home health monitoring eg. weight scales
- Consumer
 - Audio, Toys, Robots

ZentriOS-W/ZentriOS-WZ Firmware Features

The ZentriOS-W/ZentriOS-WZ firmware supplied with the AMW004 provides a wide range of features beyond the underlying hardware, and supports application development via its command API.

For complete documentation of ZentriOS-W, see:

<https://docs.zentri.com/zentrios/w/latest/>

The AMW004 supports ZentriOS-WZ firmware, which adds support for developing ZentriOS apps (ZAPs).

For complete documentation of ZentriOS-WZ, see:

<https://docs.zentri.com/zentrios/wz/latest/>

Software APIs

- [ZentriOS-W command API](#)
- [ZentriOS-WZ command API](#)
- [ZentriOS-WZ SDK and native API](#)

Interfaces

- Serial (UART, remote terminal)
- SoftAP and WLAN client (concurrent)
- I2C master
- SPI master

Servers

- TCP/TLS, UDP, HTTP(S), DHCP, DNS
- HTTP(S) Server with RESTful API and Websockets
- Fully customizable mobile responsive Web application with JavaScript and Python libraries

Clients

- TCP/TLS, UDP, NTP, Secure-SMTP, DHCP, DNS
- HTTP(S) client
- Websocket client

Setup

- Multiple Wi-Fi setup options, including via serial command and Web setup with SoftAP

Peripherals and Sensors

- GPIOs for control, indication and monitoring
- I2C-master API for interfacing to external peripherals
- SPI-master API for interfacing to external peripherals
- Automated broadcast and streaming of sensor data
- Local caching of sensor data

Update and Recovery

Wireless OTA (Over-the-Air) update to remote manage firmware using the Zentri DMS (Device Management Service)

System Management

- System configuration and monitoring via setting and getting a wide range of variables
- Configurable power states
- Sleep/wake timers

File System

- Read/write file system with appendable log files
- Storage of large files
- Optional additional bulk serial flash
- HTTP download to file system, HTTP upload from file system

Contents

1	General Description	1	7.1.3	Further Information.....	17
2	Block Diagram	2	7.2	Canada.....	18
3	Electrical Specifications.....	3	7.2.1	Labeling and User Information Requirements	18
3.1	Absolute Maximum Ratings	3	7.2.2	Approved Antenna Types	19
3.2	Recommended Operating Conditions	3	7.2.3	Further Information.....	19
3.2.1	DC Operating Conditions	3	7.3	Europe	20
3.2.2	Environmental Conditions	3	7.3.1	Labeling and User Information Requirements	20
3.3	Power Consumption	4	7.3.1	External Antenna Requirements	20
3.4	32kHz Crystal	4	7.3.2	Further Information.....	20
4	WLAN RF Specifications	5	7.4	Australia.....	21
4.1	Summary WLAN Specifications	5	7.4.1	External Antenna Requirements	21
4.2	WLAN Receiver Specifications.....	5	7.4.2	Further Information.....	21
4.3	WLAN Transmitter Specifications.....	6	7.5	New Zealand.....	21
5	Pinout and Signal Descriptions	7	7.5.1	External Antenna Requirements	21
5.1	Pinout	7	7.5.2	Further Information.....	21
5.2	Pin Description	7	8	Packaging, Handling & Storage, RoHS	22
6	Design Guidelines.....	10	8.1	Packaging.....	22
6.1	Dimensions	10	8.2	Handling & Storage.....	23
6.2	Recommended PCB Footprint.....	11	8.3	RoHS Directive	23
6.3	Routing Recommendations	11	9	Ordering Information.....	24
6.4	Soldering Information.....	12	9.1	Ordering an Unspecified ZentriOS Version 24	
6.5	Module Photograph	13	9.2	Ordering a Specific ZentriOS Version or a Custom Firmware Version.....	24
6.6	Antenna Radiation Pattern.....	13	9.3	ZentriOS Version History	24
6.7	External Antennas	14	10	Product Number Syntax.....	25
6.8	Application Examples	14	10.1	Examples.....	25
6.8.1	Power Supply.....	14	11	Revision History & Glossary	26
6.8.2	Operation using ZentriOS	15	11.1	Revision History	26
7	Regulatory Certification	16	11.2	Glossary	26
7.1	United States	16	12	References	27
7.1.1	Labeling and User Information Requirements	16			
7.1.2	Approved Antenna Types	17			

Not Recommended for New Design

1 General Description

The AMW004 module from Zentri combines a micro-controller with a BCM43362 Wi-Fi device and on-board antenna (PCB trace or uFL) to provide an advanced stand-alone Wi-Fi and networking solution.

An integrated module avoids difficult RF layout and enables designers to rapidly embed Wi-Fi and secure networking functionality into virtually any device.

The ZentriOS serial-to-Wi-Fi application may be used to fast-track module integration into end-products.

With dimensions of just 31.8 mm x 17.8 mm and a wide temperature range, the module is suitable for integration into most embedded applications.

The Wi-Fi device from Cypress includes an integrated RF transmit power amplifier and provides superior Wi-Fi performance and full compatibility with all 2.4GHz 802.11b/g/n Wi-Fi networks. An external antenna option provides additional performance and flexibility if required.

The microprocessor is based on a high-performance ARM® Cortex™-M4 32-bit RISC core operating at a frequency up to 120 MHz. The MCU incorporates high-speed embedded memory including 1MB Flash memory and 128 kB SRAM, and an extensive range of enhanced I/Os and peripherals.

The AMW004 module connects a large number of MCU pins to capitalize on the extensive MCU I/O and peripheral interfaces. The module supports the following list of interfaces, and provides additional interface combinations by leveraging MCU I/O multiplexing and alternate function capabilities.

- 10 x 12-bit A/D converters
- 1 x 12-bit D/A converters
- 2 x 4-Wire UART interfaces
- 1 x SPI-master interface
- 12 x edge/level sensitive wake inputs

The module may be powered by a single 3.3V power supply. A separate WLAN power supply pin is provided to minimize noise coupling into the WLAN subsystem, and to enable additional control for power sensitive applications.

Power consumption in various states is determined by the power consumption of the microprocessor and BCM43362 Wi-Fi chip. The power supply to the Wi-Fi chip and radio subsystem may be externally knife-switched under software control to achieve minimum power consumption in an ultra-low power backup state.

The microprocessor may be woken from low power states by connecting any of 12 different module pins.

The module incorporates a 32.768 kHz crystal to maintain an accurate real time clock. A 32kHz clock output is available on a dedicated module pin in both active and MCU powerdown modes. The 32 kHz clock output may be used to drive the clock input of other system devices. This avoids the need for an additional crystal thereby minimizing total system cost.

The module has numerous modular certifications. See Section 7, Regulatory Certification.

2 Block Diagram

The block diagram of the AMW004 module shows the main components of the module: an ARM Cortex-M4 microprocessor and BCM43362 Wi-Fi System-in-Package (SiP) module. The microprocessor and peripherals are driven by a 12MHz crystal. The integrated RTC is driven by a 32.768 kHz crystal. An integrated 1 MByte serial flash chip may be used to store additional applications, user data or firmware images as part of an over the air (OTA) update process.

The WLAN subsystem is controlled by ZentriOS enabling the module to achieve minimum power consumption when the Wi-Fi networking interface is not required.

The module includes an antenna diversity switch. The switch enables static or dynamic selection of the on-board antenna or an external antenna plugged to the u.FL connector.

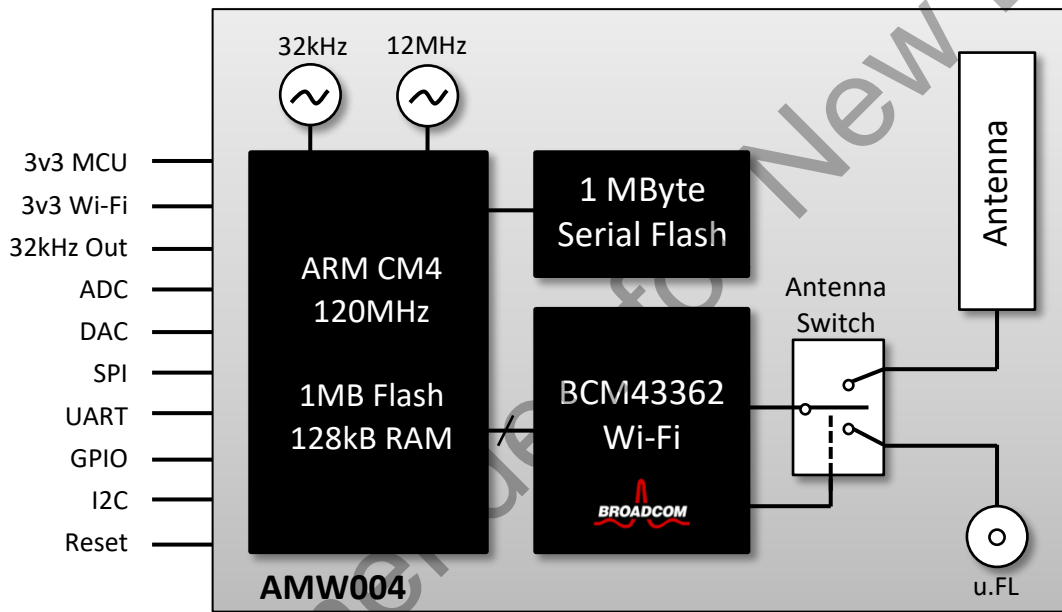

3 Electrical Specifications

3.1 Absolute Maximum Ratings

CAUTION! The absolute maximum ratings in Table 1 and Table 2 indicate levels where permanent damage to the device can occur, even if these limits are exceeded for only a brief duration. Functional operation is not guaranteed under these conditions. Operation at absolute maximum conditions for extended periods can adversely affect long-term reliability of the device.

The values in Table 1 reflect absolute maximum ratings from the respective MCU and BCM43362 datasheets.

Table 1. Absolute Maximum Voltage Ratings

Symbol	Ratings	Min	Max	Unit
VDD_3V3	External power supply voltage to MCU subsystem	-0.3	4.0	V
VDD_3V3_WIFI	External power supply voltage to WLAN subsystem	-0.5	6.0	
V _{in}	Input voltage on any other MCU pin	-0.3	4.0	

Table 2. Absolute Maximum Environmental Ratings

Characteristic	Note	Min	Max	Unit
Storage Temperature	–	-40	+125	°C
Storage Humidity	Non-condensing	–	65	%

3.2 Recommended Operating Conditions

Functional operation is not guaranteed outside the limits shown in Table 3 and Table 4, and operation outside these limits for extended periods can adversely affect long-term reliability of the device.

3.2.1 DC Operating Conditions

Table 3. Recommended DC Operating Conditions

Symbol	Ratings	Min	Typ.	Max	Unit
VDD_3V3	External power supply voltage to MCU subsystem	1.62	3.3	3.6	V
VDD_3V3_WIFI	External power supply voltage to WLAN subsystem	2.3	3.3	3.6	

Note: VDD_3V3 and VDD_3V3_WIFI must be at the same voltage when using the Wi-Fi subsystem.

3.2.2 Environmental Conditions

Table 4. Recommended Environmental Conditions

Characteristic	Note	Min	Max	Unit
Ambient Temperature	Limited by WLAN chip specification	-30	+85	°C
Relative Humidity	Non-condensing	–	85	%

3.3 Power Consumption

Table 5. Power consumption

Operational State	MCU Mode	Wi-Fi State	Typical ¹	Max ¹		Unit
				T _A = 25°C	T _A = 85°C	
Backup	MCU Backup Mode	Wi-Fi powered off	1.85	1.85	12.42	μA
Wait ³	MCU Wait Mode	Wi-Fi powered off	32.2	32.2	590	μA
Sleep	MCU Sleep Mode	Wi-Fi powered off	–	6.89	–	mA
Wi-Fi Powersave ^{2,3}	MCU Wait mode	Wi-Fi in powersave mode	0.77	–	–	mA
Active Receive	MCU Active Mode	Wi-Fi active receive	–	87.8	–	mA
Active Transmit ⁶	MCU Active Mode	Wi-Fi active transmit	–	348.8	–	mA
UDP Receive ^{2,3,4}	MCU Wait mode	Wi-Fi in powersave mode	6.9	–	–	mA
UDP Transmit ^{2,3,5}	MCU Wait mode	Wi-Fi in powersave mode	12.5	–	–	mA

Notes:

1. Total combined current consumed by all power supplies: VDD_3V3, VDD_3V3_WIFI.
2. 802.11 beacon Interval = 102.4ms, DTIM=3, Beacon Duration = 1ms @ 1Mbps.
3. MCU Wait Mode with 10μs wakeup latency
4. Average current receiving 1Mbit/s UDP at 802.11n MCS7
5. Average current transmitting 1Mbit/s UDP at 802.11n MCS7
6. Wi-Fi Transmitting at +18.5dBm CCK 11Mbit/s with 100% duty cycle, MCU Active mode with 128-bit flash-access.

3.4 32kHz Crystal

Table 6. 32kHz Crystal Specifications (reproduced from manufacturer's datasheet)

Operational State	Note	Min	Typical	Max	Unit
Frequency		–	32768	–	Hz
Frequency Tolerance		–	20	–	ppm
Frequency Ageing	Measured @25°C ±3°C	-3	–	+3	ppm

4 WLAN RF Specifications

The AMW004 WLAN radio specifications are derived from the Cypress CYW43362 WLAN radio specifications.

Unless otherwise stated, the specifications in this section apply when the operating conditions are within the limits specified in Section 3.2, Recommended Operating Conditions. Functional operation outside these limits is not guaranteed.

All specifications are measured by connecting directly to the u.FL connector.

4.1 Summary WLAN Specifications

Table 7. Summary WLAN Specifications

Feature Supported	Description
WLAN Standard	IEEE 802.11b/g/n 1x1 SISO
Frequency Band	2.400 GHz – 2.484 GHz
WLAN Channels	Channels 1 – 14
Data Rates	802.11b (1, 2, 5.5, 11 Mbps) 802.11g (6, 9, 12, 24, 36, 48, 54 Mbps) 802.11n (6.5 - 65 Mbps / MCS0 - MCS7, HT20 with 800ns GI)
Maximum Receive level @ 2.4GHz	-2.5 dBm @ 1, 2 Mbps (8% PER, 1024 octets) -8.5 dBm @ 5.5, 11 Mbps (8% PER, 1024 Octets) -12 dBm @ 6-54 Mbps (10% PER, 1000 Octets)
Maximum RF Tx Output Power	+18.5 dBm @ 802.11b (EVM < -9 dB) +13.5 dBm @ 802.11n MCS7 (EVM < -28 dB)
Carrier Frequency Accuracy	±20 ppm (26 MHz crystal with ±10 ppm @ 25°C)

4.2 WLAN Receiver Specifications

Table 8. WLAN Receiver Performance Specifications

Parameter	Condition/Notes	Min	Typical	Max	Unit
Frequency Range	–	2400	–	2500	MHz
Operating Temperature ¹	–	-30	–	+85	°C
Receive Sensitivity ² (8% PER for 1024 octet PSDU) at u.FL connector	1 Mbps DSSS	–	-94	-91	dBm
	11 Mbps CCK	–	-87	-83	
Receive Sensitivity ² (10% PER for 1000 octet PSDU) at u.FL connector ¹	6 Mbps OFDM	–	-86	-81	dBm
	54 Mbps OFDM	–	-73	-69	

Parameter	Condition/Notes	Min	Typical	Max	Unit
Receive Sensitivity ² (10% PER for 4096 octet PSDU) at u.FL connector. Defined for default parameters: GF, 800ns GI, and non-STBC	65 Mbps MCS0, HT20	-	-86	-81	dBm
	65 Mbps MCS7, HT20	-	-70	-65	
Max. Receive Level @ 2.4GHz	@ 1, 2 Mbps (8% PER, 1024 octets)	-2	-	-	dBm
	@ 5.5, 11 Mbps (8% PER, 1024 Octets)	-8	-	-	
	@ 6-54 Mbps (10% PER, 1000 Octets)	-11.5	-	-	

Notes:

1. Operation below -20°C and above +65°C with parameter derating per Note 2
2. Derate receive sensitivity by 1.5dB for operation between temperatures of -30°C to -20°C and 65°C to 85°C

4.3 WLAN Transmitter Specifications

Table 9. WLAN Transmitter Performance Specifications

Parameter	Condition/Notes	Min	Typical	Max	Unit	
Frequency Range	-	2400	-	2500	MHz	
Operating Temperature ¹	-	-30	-	+85	°C	
Transmit power ² measured at u.FL connector for highest power level setting at 25°C, VDD-3V3_RF_IN=3.3V with spectral mask and EVM compliance	EVM does NOT exceed :					
	1 Mbps DSSS	-11 dB	+15.5	+17	+18.5	dBm
	11 Mbps CCK	-11 dB	+15.5	+17	+18.5	
	6 Mbps OFDM	-22 dB	+12.5	+14	+15.5	
	54 Mbps OFDM	-25 dB	+12.5	+14	+15.5	
	MCS0, HT20	-22 dB	+10.5	+12	+13.5	
MCS7, HT20	-28 dB	+10.5	+12	+13.5		

Notes:

1. Operation below -20°C and above +65°C with parameter derating per Note 2
2. Derate transmit power by 1.5dB for operation between temperatures of -30°C to -20°C and 65°C to 85°C

5 Pinout and Signal Descriptions

5.1 Pinout

A top view of the AMW004 pinout is depicted in Figure 1. All dimensions are in thousands of an inch. A recommended footprint is provided in Section 6.2.

Figure 1. AMW004 Pinout (TOP View – Pins NOT visible from top!)

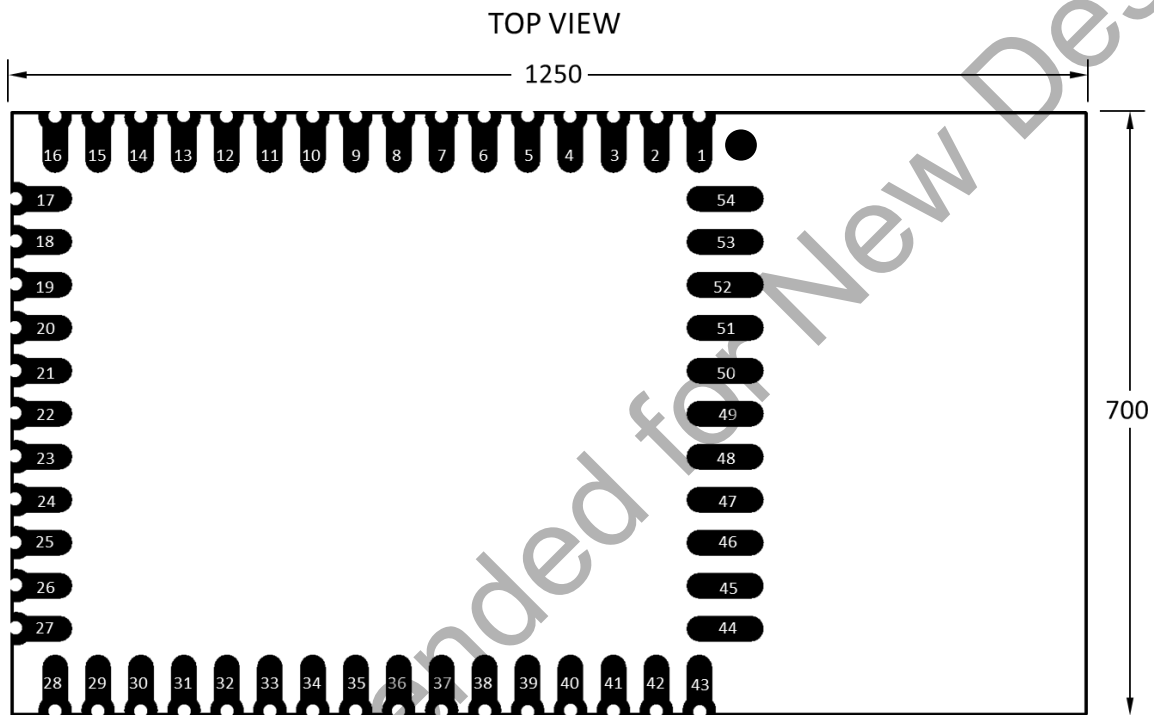

5.2 Pin Description

Table 10. AMW004 Pin Definitions

Pin	Name	Type ¹	Primary Function	Alternate & Other Function(s)
1	GND	S	Ground	-
2	VDD_3V3_WIFI	S	3.3V WLAN supply	-
3	NC1	NC	DO NOT CONNECT	-
4	NC2	NC	DO NOT CONNECT	-
5	NC3	NC	DO NOT CONNECT	-
6	NC4	NC	DO NOT CONNECT	-
7	GPIO_0	I/O	GPIO	PWM3, DAC0
8	GPIO_1	I/O	GPIO	-

Pin	Name	Type ¹	Primary Function	Alternate & Other Function(s)
9	GPIO_2	I/O	GPIO	-
10	OSC_32K_OUT	O	OSC_32K_OUT	-
11	GPIO_3	I/O	GPIO	ADC4, WAKE
12	GPIO_4	I/O	GPIO	ADC5
13	GPIO_5	I/O	GPIO	PWM0, WAKE
14	GPIO_6	I/O	GPIO	PWM1, WAKE
15	GPIO_7	I/O	GPIO	PWM3, ADC0
16	GND	S	Ground	-
17	GPIO_8	I/O	GPIO	ADC1
18	GPIO_9	I/O	GPIO	PWM0, ADC2, WAKE
19	GPIO_10	I/O	GPIO	PWM3, WAKE
20	GPIO_11	I/O	GPIO	PWM2, WAKE
21	GPIO_12	I/O	GPIO	PWM1, ADC3, WAKE
22	GND	S	Ground	-
23	GPIO_13	I/O	UART1_RX	GPIO, ADC6
24	GPIO_14	I/O	UART1_TX	GPIO, ADC7
25	NC5	NC	DO NOT CONNECT	-
26	GPIO_15	I/O	UART1_RTS	GPIO, PWM1
27	GPIO_16	I/O	UART1_CTS	GPIO, PWM2
28	GND	S	Ground	-
29	VDD_3V3	S	3.3V MCU supply	-
30	GPIO_17	I/O	SPI_CLK ³	WAKE. Not available as digital I/O
31	GPIO_18	O	SPI_MOSI ³	Not available as digital I/O
32	GPIO_19	I	SPI_MISO ³	Not available as digital I/O
33	GPIO_20	I/O	GPIO	PWM0, WAKE
34	GPIO_21	I/O	GPIO	PWM0, ADC8
35	GPIO_22	I/O	GPIO	ADC9
36	GPIO_23	I/O	GPIO	-
37	GPIO_24	I/O	GPIO	WAKE
38	GPIO_25	I/O	GPIO	UART0_TX
39	GPIO_26	I/O	GPIO	UART0_RX, WAKE

Pin	Name	Type ¹	Primary Function	Alternate & Other Function(s)
40	RESET_N ²	I	System Reset	-
41	GPIO_27	I/O	GPIO	I2C_SCL, WAKE
42	GPIO_28	I/O	GPIO	I2C_SDA
43-54	GND	S	Ground	-

Notes:

1. I = Input, O = Output, S = Supply, NC = No connect
2. The AMW004 RESET_N pin is connected directly to the MCU NRST pin. When the MCU is placed in low-power BACKUP mode, the NRST pin is disabled and RESET_N can NOT be used to reset the module. To enable reset when MCU BACKUP mode is used, the RESET_N pin must be connected to one of the WAKE pins, and the WAKE pin must be enabled via software.
3. Connected to SPI serial flash inside module

6 Design Guidelines

6.1 Dimensions

Figure 2 - AMW004 Wallaby Dimensions

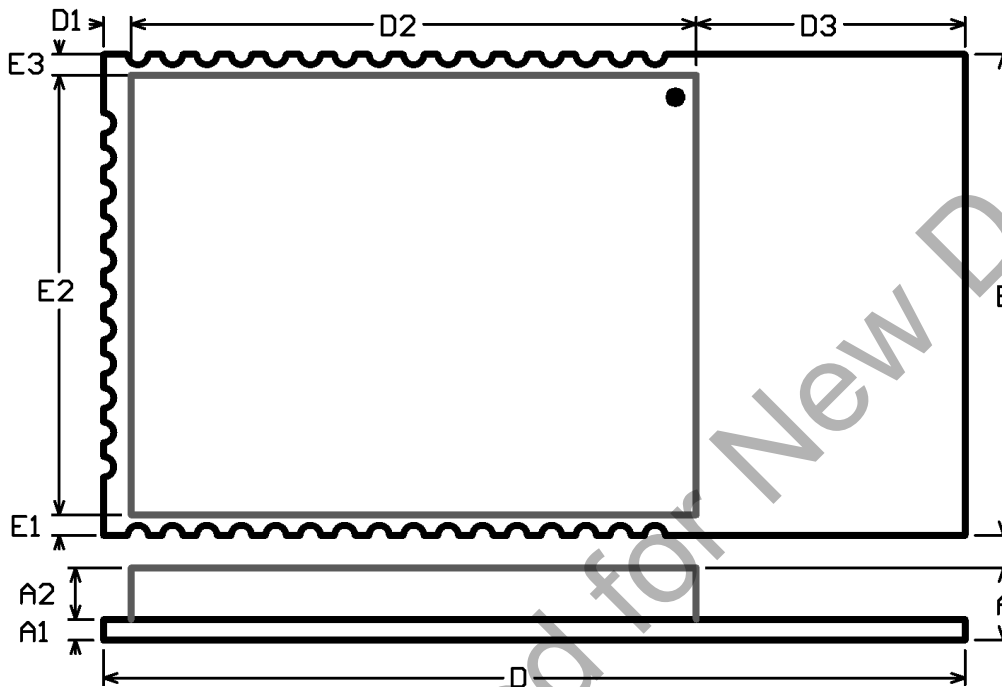

Table 11 - AMW004 Wallaby Dimensions

Symbol	Imperial (thou)	Tolerance (thou)	Metric (mm)	Tolerance (mm)
A	105	±6	2.67	±0.15
A1	30	±3	0.76	±0.08
A2	75	±6	1.91	±0.15
D	1250	±5	31.75	±0.13
D1	40	±5	1.02	±0.13
D2	820	±6	20.83	±0.15
D3	390	±5	9.91	±0.13
E	700	±5	17.78	±0.13
E1	30	±5	0.76	±0.13
E2	640	±6	16.26	±0.15
E3	30	±5	0.76	±0.13

6.2 Recommended PCB Footprint

Figure 3. AMW004 Recommended Footprint (Top view, all dimensions in thousands of an inch)

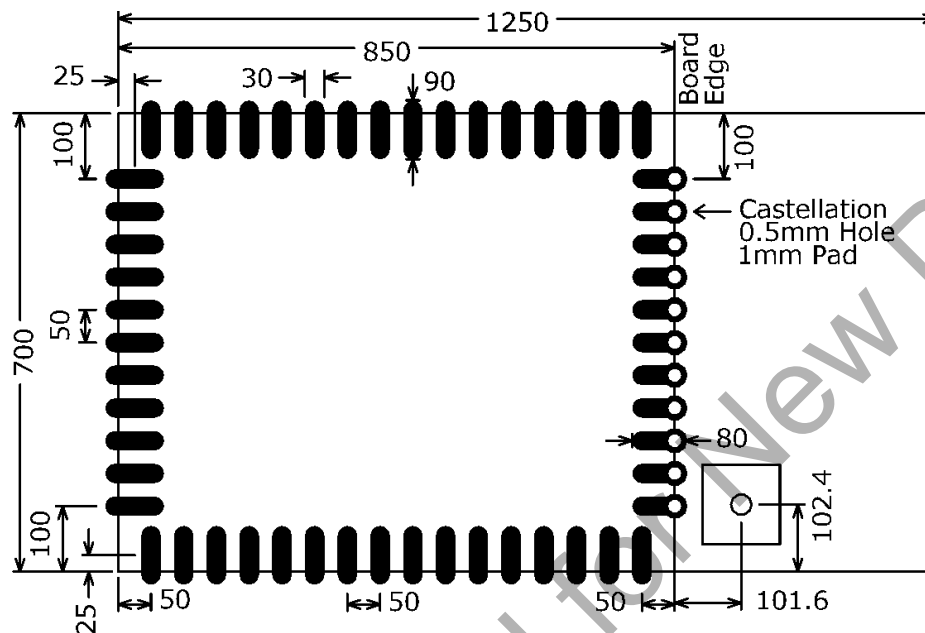

Figure 3 shows the recommended PCB footprint for the AMW004 module. All dimensions are in thousands of an inch.

The physical location of the u.FL antenna connector in the bottom-right corner of the picture is provided for reference ONLY. The connector is located on the top-side of the module and does not connect to the PCB.

The addition of castellations on the periphery of the module carrier board directly beneath the end of the module nearest the antenna (as depicted in Figure 3) are strongly recommended.

6.3 Routing Recommendations

When designing a carrier board, the addition of ground fill directly underneath the AMW004 module, rather than signal or power traces, is recommended.

All ground pads adjacent to antenna pins must be connected to a solid ground plane. Do not route ANY metal or PCB traces underneath the printed PCB antenna!

For optimal range, provide a clearance of approximately 4-5 mm (0.2") above, below and to the front and each side of the antenna end of the module. The antenna has been explicitly tuned with the expectation it will be positioned within close proximity of a plastic enclosure or printed circuit board.

Failure to comply with these recommendations will almost certainly result in degraded performance of the radio receiver and/or transmitter.

6.4 Soldering Information

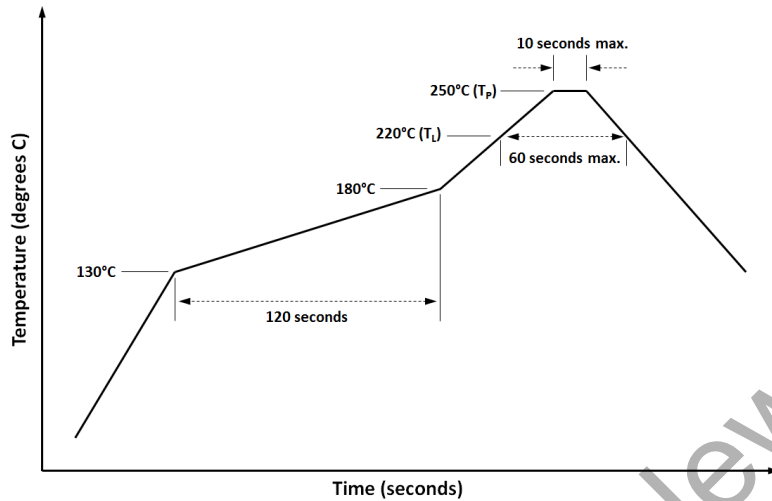
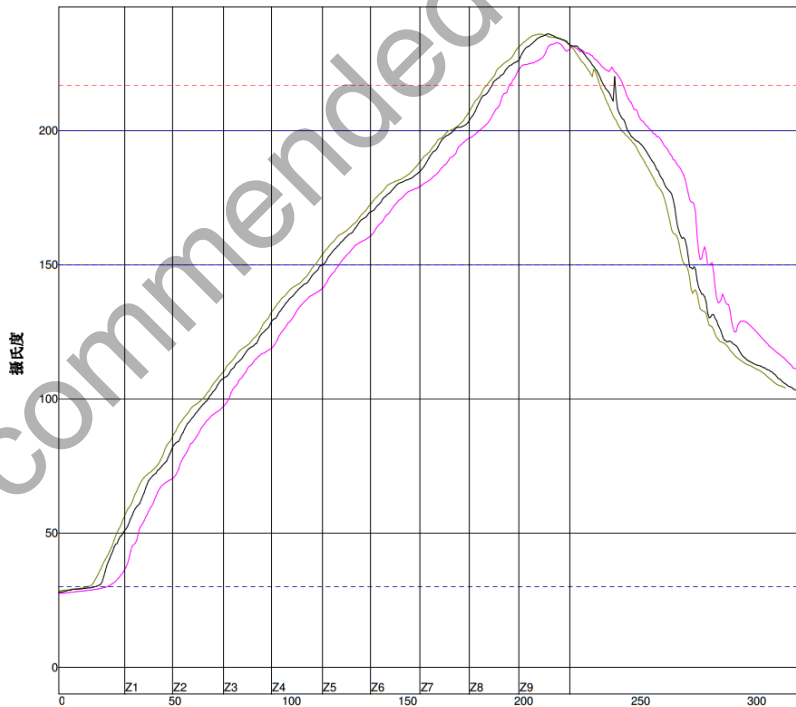

Figure 4 - Recommended solder reflow profile

Oven Name: HELLER

Process Window Name: ALPHA_OM325

Setpoints (摄氏度)									
Zone	1	2	3	4	5	6	7	8	9
Top	100	120	140	160	180	200	235	255	250
Bottom	100	120	140	160	180	200	235	255	250
Conveyor Speed (cm/min): 70.0									



	PWI= 67%	Max Rising Slope	Max Falling Slope	Preheat	30-150C	Soak Time 150-200C	Reflow Time /217C	Peak Temp				
TC2-	1.64	9%	-4.74	-87%	99.98	50%	60.17	-71%	48.88	-37%	232.83	-77%
TC4-	1.62	8%	-3.27	-14%	98.09	45%	57.87	-75%	48.45	-39%	235.95	-52%
TC5-	1.65	10%	-3.43	-22%	98.04	45%	56.43	-82%	48.08	-40%	236.06	-52%
Delta	0.03		1.47		1.94		3.74		0.80			3.23

Figure 5 - Example solder reflow profile (AMW004-E03 evaluation board)

6.5 Module Photograph

Figure 6. AMW004 Photograph (Top)



6.6 Antenna Radiation Pattern

The antenna radiation pattern of the AMW004 on-board PCB antenna shown in Figure 7 was measured with an AMW004 module mounted on an AMW004-E03 evaluation board. For each (0°, 180°) pair of X, Y, Z plots, the axis is perpendicular to the page. The orientation of the module is shown for reference on the 0° Y-axis plot. The maximum antenna gain is 3.18 dBi.

Figure 7. Antenna radiation pattern of the on-board antenna

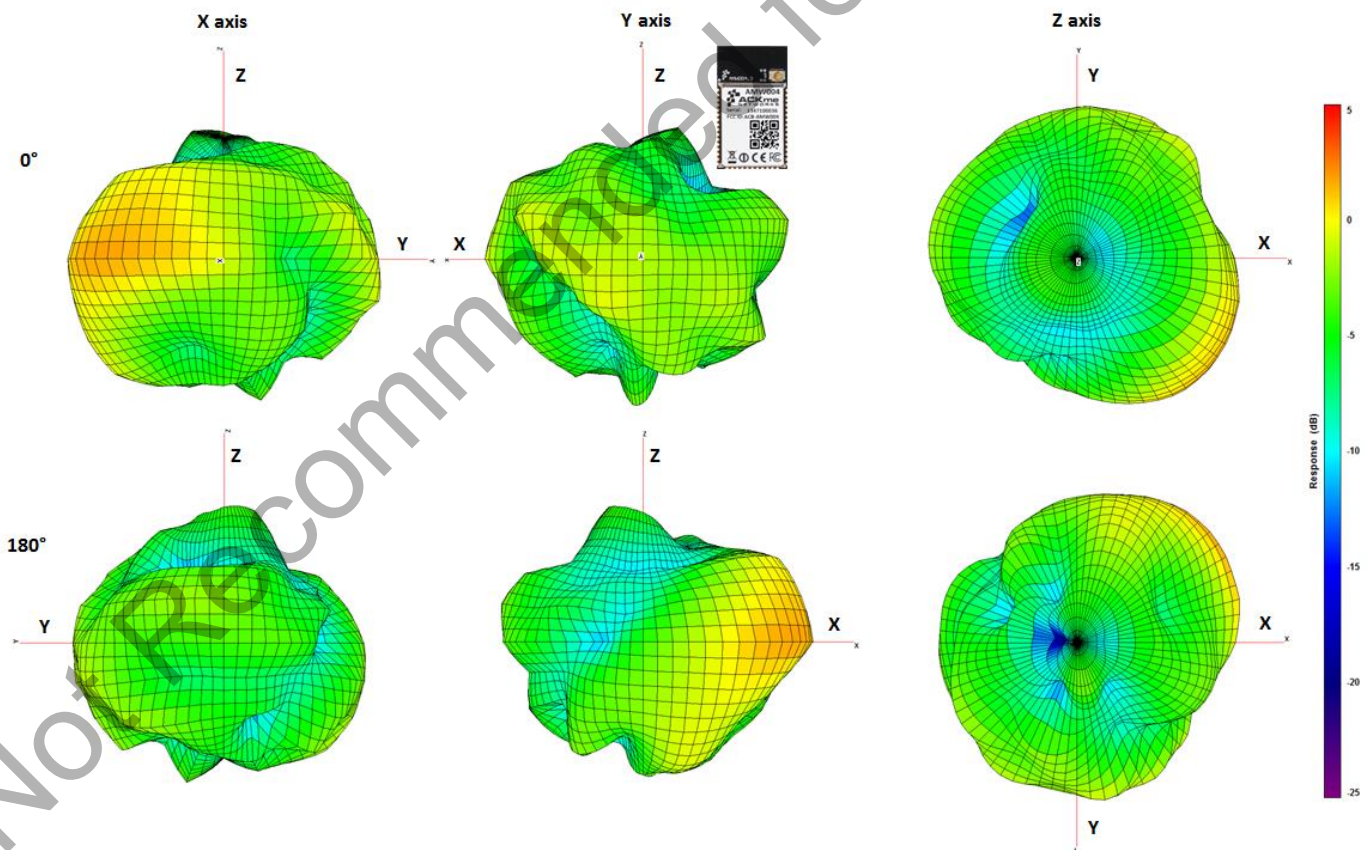

6.7 External Antennas

The AMW004 module supports an external antenna. The monopole antennas listed in Table 1 have been certified for use with the AMW004 when connected to the u.FL antenna port via a 50 ohm miniature coax cable.

Further information about both antennas, pictured in Figure 8 and Figure 9, is available online at <http://zentri.com>.

Table 12 - Certified Antenna Types

Model	Type	Gain (dBi)
Printed antenna	PCB trace	3.2
ACA_1SSRPP_2400	Monopole	0.6
ACA_4HSRPP_2458	Monopole	1.0



Figure 8 - ACA-1SSRPP-2400



Figure 9 - ACA-4HSRPP-2458

NOTE: If the external antenna port is configured for use with software, the port must be terminated in 50 ohms. Failure to terminate the antenna port will result in degraded radio performance.

6.8 Application Examples

This section provides circuit examples demonstrating how to configure the module to meet various application requirements.

For hardware design guidelines, see: <https://docs.zentri.com/hardware/zentri/amwx06/amwx06-hardware-design#pcb-layout>

The general guidelines for the AMWx06 devices apply to all Zentri devices.

6.8.1 Power Supply

The module requires at least 10μF of bulk capacitance between VDD_3V3 pin 29 and ground and between VDD_3V3_WIFI pin 2 and ground. The WLAN radio performance may be significantly degraded if ground Pins 44-54 near the antenna are not connected to a solid ground.

The VDD_3V3 and VDD_3V3_WIFI power supply pins must be connected together as shown in Figure 10.

Figure 10. VDD 3V3 Power Supply

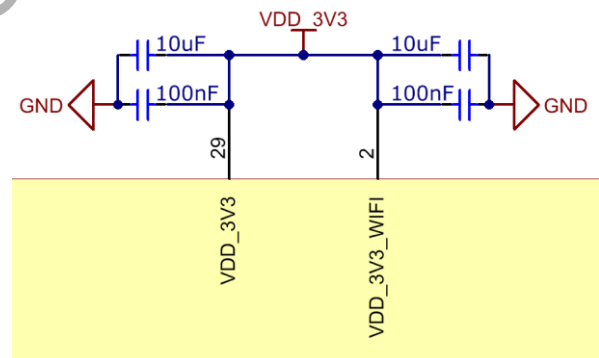

6.8.2 Operation using ZentriOS

Each AMW004 module is pre-installed with and licensed to use ZentriOS, Zentri’s feature-rich and reliable Wi-Fi networking application. The module can be used either with an external host microcontroller via the serial interface command API, or via a Native API app running on the internal microcontroller.

For more details see <https://docs.zentri.com/zentrios>.

When using the command API, the module requires a connection to a UART serial interface. A host processor connects to pins 23/24 as shown in Figure 11 if the default UART1 serial interface is used. Use of the hardware flow control RTS/CTS pins is optional (but recommended) for baud rates below 1 Mbit/s. The default UART settings are 115200 8N1 (8 data bits, No parity and 1 stop bit).

Figure 11. Using the AMW004 Module with ZentriOS and a UART serial interface

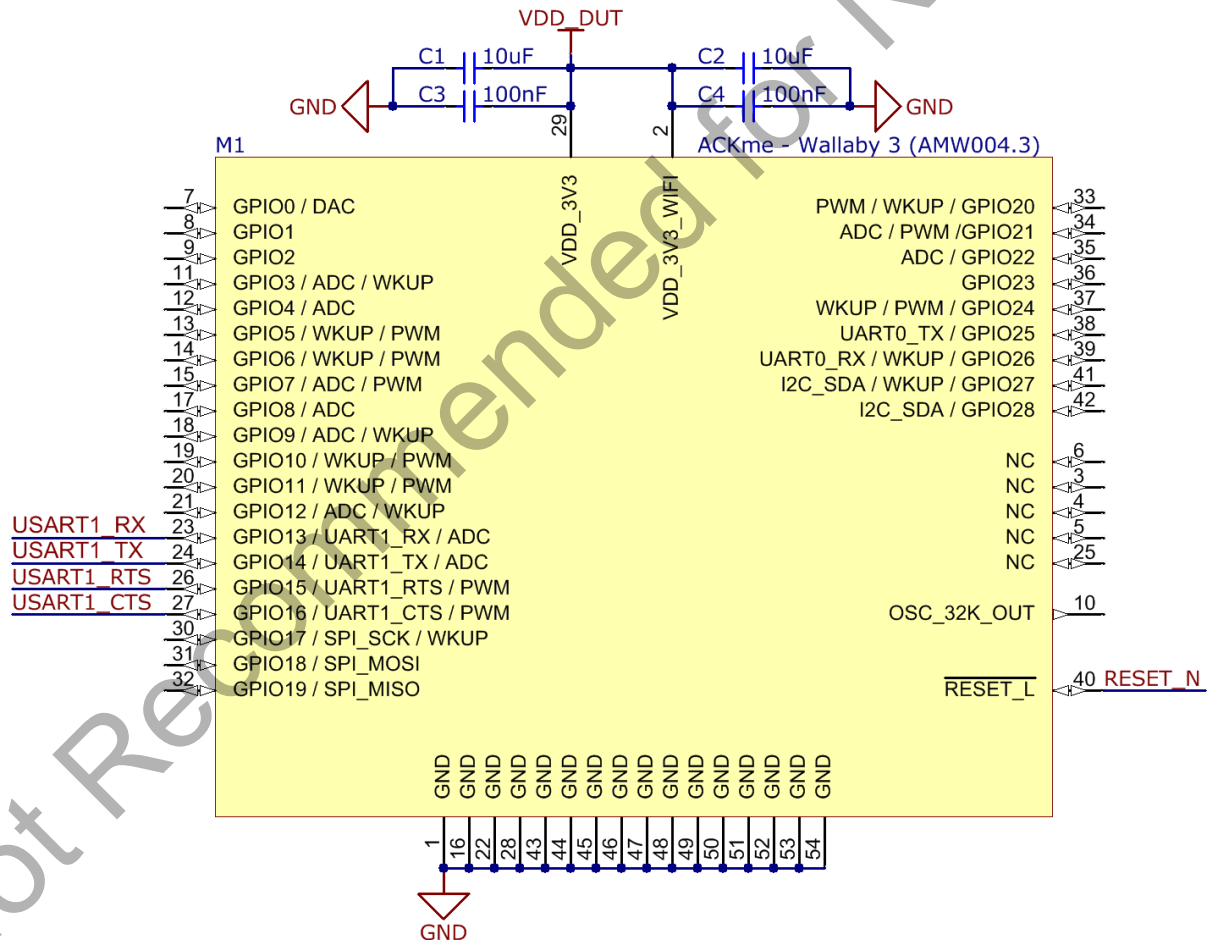

7 Regulatory Certification

The AMW004 module has been certified for operation in various regulatory domains. This section outlines certification information specific to the following countries and regions:

- United States
- Canada
- Europe
- Australia
- New Zealand

The certifications listed in this section are valid at the time of publication. For up-to-date information refer to Zentri documentation online at:

<https://docs.zentri.com>.

All AMW004 test reports are available on the Zentri website:

<https://docs.zentri.com/zentri/docresources#amw004>

Should you require regulatory certification for the AMW004 module in a country or region not listed, please contact your local Zentri sales office or create a support request via our website at

<https://www.silabs.com/about-us/contact-us>.

7.1 United States

The Zentri AMW004 module has received Federal Communications Commission (FCC) CFR47 Telecommunications, Part 15 Sub-part C “Intentional Radiators” modular approval in accordance with Part 15.212 Modular Transmitter approval. Modular approval allows the end user to integrate the AMW004 module into a finished product without obtaining subsequent and separate FCC approvals for intentional radiation, provided no changes or modifications are made to the module circuitry. Changes or modifications could void the user’s authority to operate the equipment. The end user must comply with all of the instructions provided by the Grantee which indicate installation and/or operating conditions necessary for compliance.

The finished product is required to comply with all applicable FCC equipment authorization, regulations, requirements, and equipment functions not associated with the transmitter module portion. For example, compliance must be demonstrated to regulations for

other transmitter components within the host product; to requirements for unintentional radiators (Part 15 Sub-part B “Unintentional Radiators”), such as digital devices, computer peripherals, radio receivers, etc.; and to additional authorization requirements for non-transmitter functions on the transmitter module (i.e. Verification, or Declaration of Conformity) (e.g., transmitter modules may also contain digital logic functions) as appropriate.

7.1.1 Labeling and User Information Requirements

The AMW004 module has been labelled with a unique FCC ID number, and if the FCC ID is not visible when the module is installed inside another device, then the outside of the finished product into which the module is installed must also display a label referring to the enclosed module. This exterior label can use wording as follows:

Contains FCC ID: 2ABPY-61F8D

This device complies with Part 15 of the FCC Rules.

Operation is subject to the following two conditions:

(1) this device may not cause harmful interference, and (2) this device must accept any interference received, including interference that may cause undesired operation.

The user manual for the product should include the following statement:

This equipment has been tested and found to comply with the limits for a Class B digital device, pursuant to part 15 of the FCC Rules. These limits are designed to provide reasonable protection against harmful interference in a residential installation. This equipment generates, uses and can radiate radio frequency energy and if not installed and used in accordance with the instructions, may cause harmful interference to radio communications. However, there is no guarantee that interference will not occur in a particular installation. If this equipment does cause harmful interference to radio or television reception, which can be determined by turning the equipment off and on, the user is encouraged to try to correct the interference by one or more of the following measures:

- Reorient or relocate the receiving antenna.
- Increase the separation between the equipment and receiver.
- Connect the equipment into an outlet on a circuit different from that to which the receiver is connected.
- Consult the dealer or an experienced radio/TV technician for help.

Additional information on labeling and user information requirements for Part 15 devices can be found in KDB Publication 784748 available at the FCC Office of Engineering and Technology (OET) Laboratory Division Knowledge Database (KDB).

RF Exposure

All transmitters regulated by FCC must comply with RF exposure requirements. OET Bulletin 65, Evaluating Compliance with FCC Guidelines for Human Exposure to Radio Frequency Electromagnetic Fields, provides assistance in determining whether proposed or existing transmitting facilities, operations or devices comply with limits for human exposure to Radio Frequency (RF) fields adopted by the Federal Communications Commission (FCC). The bulletin offers guidelines and suggestions for evaluating compliance.

If appropriate, compliance with exposure guidelines for mobile and unlicensed devices can be accomplished by the use of warning labels and by providing users with information concerning minimum separation distances from transmitting structures and proper installation of antennas.

The following statement must be included as a CAUTION statement in manuals and OEM products to alert users of FCC RF exposure compliance:

To satisfy FCC RF Exposure requirements for mobile and base station transmission devices, a separation distance of 20 cm or more should be maintained between the antenna of this device and persons during operation. To ensure compliance, operation at closer than this distance is not recommended. The antenna(s) used for this transmitter must not be co-located or operating in conjunction with any other antenna or transmitter

If the AMW004 module is used in a portable application (i.e., the antenna is less than 20 cm from persons during operation), the integrator is responsible for performing Specific Absorption Rate (SAR) testing in accordance with FCC rules 2.1091.

7.1.2 Approved Antenna Types

Modular approval testing of the AMW004 was performed with the antenna types listed in Table 12 - Certified Antenna Types.

To maintain modular approval in the United States, only the tested antenna types shall be used. It is permissible to use different antenna manufacturers provided the antenna types match: in-band and out-of-band radiation patterns and the antenna gain must be similar to those tested.

7.1.3 Further Information

Additional information regarding FCC certification and use of the AMW004 module in the United States is available from the following sources.

- Federal Communications Commission (FCC)
<http://www.fcc.gov>

7.2 Canada

The AMW004 module has been certified for use in Canada under Industry Canada (IC) Radio Standards Specification (RSS) RSS-210 and RSSGen. Modular approval permits the installation of a module in a host device without the need to recertify the device.

7.2.1 Labeling and User Information Requirements

Labeling Requirements for the Host Device (from Section 3.2.1, RSS-Gen, Issue 3, December 2010): The host device shall be properly labeled to identify the module within the host device.

The Industry Canada certification label of a module shall be clearly visible at all times when installed in the host device, otherwise the host device must be labeled to display the Industry Canada certification number of the module, preceded by the words “Contains transmitter module”, or the word “Contains”, or similar wording expressing the same meaning, as follows:

Contains transmitter module IC: 11685A-61F8D

User Manual Notice for License-Exempt Radio Apparatus (from Section 7.1.3 RSS-Gen, Issue 3, December 2010): User manuals for license-exempt radio apparatus shall contain the following or equivalent notice in a conspicuous location in the user manual or alternatively on the device or both:

This device complies with Industry Canada license-exempt RSS standard(s). Operation is subject to the following two conditions: (1) this device may not cause interference, and (2) this device must accept any interference, including interference that may cause undesired operation of the device.

Le présent appareil est conforme aux CNR d'Industrie Canada applicables aux appareils radio exempts de licence. L'exploitation est autorisée aux deux conditions suivantes: (1) l'appareil ne doit pas produire de brouillage, et (2) l'utilisateur de l'appareil doit accepter tout brouillage radioélectrique subi, même si le brouillage est susceptible d'en compromettre le fonctionnement.

Transmitter Antenna Notification (from Section 7.1.2 RSS-Gen, Issue 3, December 2010): User manuals for transmitters shall display the following notice in a conspicuous location:

Under Industry Canada regulations, this radio transmitter may only operate using an antenna of a type and maximum (or lesser) gain approved for the transmitter by Industry Canada. To reduce potential radio interference to other users, the antenna type and its gain should be so chosen that the equivalent isotropically radiated power (EIRP) is not more than that necessary for successful communication.

Conformément à la réglementation d'Industrie Canada, le présent émetteur radio peut fonctionner avec une antenne d'un type et d'un gain maximal (ou inférieur) approuvé pour l'émetteur par Industrie Canada. Dans le but de réduire les risques de brouillage radioélectrique à l'intention des autres utilisateurs, il faut choisir le type d'antenne et son gain de sorte que la puissance isotrope rayonnée équivalente (p.i.r.e.) ne dépasse pas l'intensité nécessaire à l'établissement d'une communication satisfaisante.

The above notice may be affixed to the device instead of displayed in the user manual.

User manuals for transmitters equipped with detachable antennas shall also contain the following notice in a conspicuous location:

This radio transmitter (identify the device by certification number, or model number if Category II) has been approved by Industry Canada to operate with the antenna types listed below with the maximum permissible gain and required antenna impedance for each antenna type indicated. Antenna types not included in this list, having a gain greater than the maximum gain indicated for that type, are strictly prohibited for use with this device.

Le présent émetteur radio (identifier le dispositif par son numéro de certification ou son numéro de modèle s'il fait partie du matériel de catégorie I) a été approuvé par Industrie Canada pour fonctionner avec les types d'antenne énumérés ci-dessous et ayant un gain admissible maximal et l'impédance requise pour chaque type d'antenne. Les types d'antenne non inclus dans cette liste, ou dont le gain est supérieur au gain maximal indiqué, sont strictement interdits pour l'exploitation de l'émetteur.

Immediately following the above notice, the manufacturer shall provide a list of all antenna types approved for use with the transmitter, indicating the maximum permissible antenna gain (in dBi) and required impedance for each.

7.2.2 Approved Antenna Types

Modular approval testing of the AMW004 was performed with the antenna types listed in Table 12 - Certified Antenna Types.

Transmitter Antenna (from Section 7.1.2 RSS-Gen, Issue 3, December 2010):

The AMW004 module can only be sold or operated with antennas with which it was approved. Transmitter may be approved with multiple antenna types. An antenna type comprises antennas having similar in-band and out-of-band radiation patterns. Testing shall be performed using the highest gain antenna of each combination of transmitter and antenna type for which approval is being sought, with the transmitter output power set at the maximum level. Any antenna of the same type having equal or lesser gain as an antenna that had been successfully tested with the transmitter,

will also be considered approved with the transmitter, and may be used and marketed with the transmitter.

When a measurement at the antenna connector is used to determine RF output power, the effective gain of the device's antenna shall be stated, based on measurement or on data from the antenna manufacturer.

For transmitters of output power greater than 10 milliwatts, the total antenna gain shall be added to the measured RF output power to demonstrate compliance to the specified radiated power limits.

7.2.3 Further Information

Additional information may be obtained from the Industry Canada website at <http://www.ic.gc.ca>

7.3 Europe

The AMW004 module is a Radio Equipment Directive (RED) assessed radio module that is CE marked and has been manufactured and tested with the intention of being integrated into a final product.

The AMW004 module has been tested to Radio Equipment Directive (2014/53/EU) and R&TTE Directive (1999/5/EC).

See Table 13. European Compliance Testing.

A Notified Body Opinion has also been issued.

See: [AMW004 Wallaby CE Certification Package](#)

The R&TTE Compliance Association provides guidance on modular devices in the document titled Technical Guidance Note 01.

NOTE: To maintain conformance with the tests listed in Table 13. European Compliance Testing, the module shall be installed in accordance with the installation instructions in this data sheet and shall not be modified.

When integrating a radio module into a completed product the integrator becomes the manufacturer of the final product and is therefore responsible for demonstrating compliance of the final product with the essential requirements of the R&TTE Directive.

7.3.1 Labeling and User Information Requirements

The label on the final product which contains the AMW004 module must follow CE marking requirements. The R&TTE Compliance Association Technical Guidance Note 01 provides guidance on final product CE marking.

7.3.1 External Antenna Requirements

From R&TTE Compliance Association document Technical Guidance Note 01:

Provided the integrator installing an assessed radio module with an integral or specific antenna and installed in conformance with the radio module manufacturer's installation instructions requires no further evaluation under Article 3.2 of the R&TTE Directive and does not require further involvement of an R&TTE Directive Notified Body for the final product. [Section 2.2.4]

The European Compliance Testing was performed using the antenna types listed in Table 12 - Certified Antenna Types.

7.3.2 Further Information

Further information may be obtained by searching for:

- European Conference of Postal and Telecommunications Administrations (CEPT)
- Radio Equipment Directive (RED), which replaces Radio and Telecommunications Terminal Equipment (R&TTE)

Table 13. European Compliance Testing

Certification	Standard	Report Number	Date	Laboratory
Safety	EN 60950-1:2006+A11:2009+A1:2010, A12:2011, A2:2013	W6M21401-13800-L	May 6, 2014	Worldwide Testing Services (Taiwan) Co., Ltd.
Health	EN 62311:2008	EA533175	May 1, 2015	Sporton International Inc. (Taiwan)
EMC	EN 301 489-1 v2.1.1 (2016-11), Class B EN301 489-17 v3.1.1 (2016-11)	21274930_001	Jul 11, 2017	TÜV Rheinland
	EN55022:2010/AC:2011, Class B EN 55024:2010	EH533175	Apr 10, 2015	Sporton International Inc. (Taiwan)
Radio	EN 300 328 v2.1.1 (2015-02)	21274940_001	Jul 10, 2017	TÜV Rheinland
Notified Body Opinion	CE1177	TCF-972TC15	May 19, 2015	TIMCO Engineering, Inc.

7.4 Australia

Australian radio regulations do not provide a modular approval policy similar to the United States (FCC) or Canada (IC). However, AMW004 module test reports may be used in part to demonstrate compliance in accordance with ACMA Radio communications “Short Range Devices” Standard 2004 which references Australia/New Zealand industry standard AS/NZS-4268:2012. AMW004 RF transmitter test reports may be used as part of the product certification and compliance folder. For further information regarding the availability of RF test reports, please contact Zentri via our website at <https://www.silabs.com/about-us/contact-us>.

7.4.1 External Antenna Requirements

Compliance tests were performed using antenna types listed in Table 12 - Certified Antenna Types.

If an external antenna is used with the AMW004 module, additional testing of the end product is needed to meet Australian regulatory requirements.

7.4.2 Further Information

Additional information may be obtained from the Australian Communications and Media Authority website at <http://www.acma.gov.au>.

7.5 New Zealand

New Zealand radio regulations do not provide a modular approval policy similar to the United States (FCC) or Canada (IC). However, AMW004 module test reports may be used in part to demonstrate compliance with the New Zealand “General User Radio License for Short Range Devices”. New Zealand Radio communications (Radio Standards) Notice 2010 references Australia/New Zealand industry standard AS/NZS-4268:2012. AMW004 RF transmitter test reports may be used as part of the product certification and compliance folder. For further information regarding the availability of RF test reports, please contact Zentri via our website at <https://www.silabs.com/about-us/contact-us>.

7.5.1 External Antenna Requirements

Compliance tests were performed using antenna types listed in Table 12 - Certified Antenna Types.

If an external antenna is used with the AMW004 module, additional testing of the end product is needed to meet New Zealand regulatory requirements.

7.5.2 Further Information

Additional information may be obtained from the New Zealand Radio Spectrum Ministry of Economic Development website at <http://www.rsm.govt.nz>.

8 Packaging, Handling & Storage, RoHS

8.1 Packaging

The tray packaging of AMW004 modules is shipped in a moisture resistant sealed bag as shown in Figure 12. The shelf life of the sealed bag is 12 months at 40°C and <90% Relative Humidity (RH). Please refer to the bag seal date. For package quantity, see section 9, Ordering Information.

Figure 12. Example of Typical MSL3 Packaging



8.2 Handling & Storage



CAUTION MSL3 Sensitive Device!

The AMW004 module is a moisture sensitive device rated at Moisture Sensitive Level 3 (MSL3) per **IPC/JEDEC J-STD-20**.

After opening the moisture sealed storage bag, modules that will be subjected to reflow solder or other high temperature processes must be:

1. mounted to a circuit board within 168 hours at factory conditions ($\leq 30^{\circ}\text{C}$ and $< 60\% \text{ RH}$)

OR

2. continuously stored per **IPC/JEDEC J-STD-033**

Modules that have been exposed to moisture and environmental conditions exceeding packaging and storage conditions **MUST** be baked before mounting according to **IPC/JEDEC J-STD-033**.

Failure to meet packaging and storage conditions will result in irreparable damage to modules during solder reflow.

8.3 RoHS Directive

The AMW004 module is produced according to the RoHS (Restriction of the use of certain Hazardous Substances in electrical and electronic equipment) directive and complies with the directive.

Recommendation: Bake product prior to any solder flow operation. This ensures optimal protection.

9 Ordering Information

You can order AMW004 in trays of 21 units, pre-loaded with an unspecified ZentriOS, or with either a specific ZentriOS version or a version of your embedded custom application.

When you order, refer to the OPN (Orderable Part Number), as described below. For examples, see Table 14. Ordering Information.

9.1 Ordering an Unspecified ZentriOS Version

Order OPN: AMW004

When ordering an unspecified ZentriOS version, the OPN is simply AMW004.

When ZentriOS version is unspecified, orders of AMW004 modules ship with whatever versions of ZentriOS are available. The ZentriOS version is not guaranteed to be the same for all items shipped. Unspecified ZentriOS versions are suitable for sampling, evaluation, and pilot builds.

Upon delivery, you can update modules individually, via OTA (Over-The-Air update), with a specific ZentriOS version.

9.2 Ordering a Specific ZentriOS Version or a Custom Firmware Version

ZentriOS version order OPN: AMW006-x.y.z

Custom firmware version OPN: AMW004-xxxxxx

Volume orders are delivered in trays. To ensure consistency, an OPN is specified, corresponding to a specific version.

ZentriOS version: the OPN is of the form AMW004-x.y.z, where **x** is the major version, **y** is the minor version and **z** is the patch version.

Custom firmware version: the OPN is of the form AMW004-xxxxxx, where **xxxxxx** is a unique ID indicating a specific product version. Zentri ships trays with the product version specified.

Custom firmware is a custom product bundle that includes a specific version of ZentriOS. An AMW004 ZAP product bundle also contains a ZAP (ZentriOS application).

Table 14. Ordering Information

Order Type	Delivery Format	Example OPN
Unspecified firmware		AMW004
Specified ZentriOS version	21 unit tray	AMW004-3.3.0
Custom firmware	21 unit tray	AMW004-H35GHJ

9.3 ZentriOS Version History

ZentriOS firmware revision history is available online at:

ZentriOS-W: <https://docs.zentri.com/zentrios/editions-and-versions#zentriosw>

ZentriOS-WZ: <https://docs.zentri.com/zentrios/editions-and-versions#zentrioswz>

10 Product Number Syntax

Zentri hardware products are numbered according to a scheme that indicates the product type technology, module type, board model and revision of the product.

Modules have the numbering scheme:

A[Product Type][Technology][Module Model].[Revision]

Evaluation boards and adapters start with the module and have the numbering scheme:

A[Product Type][Technology][Module Model]-[Board Type][Board Model].[Revision]

- **Product Type:**
Single character: **M**: Module, **S**: System-in-Package
- **Technology**
Single character: **S**: Bluetooth Smart (Bluetooth Low Energy or BLE) technology, **W**: Wi-Fi technology
- **Module Model**
Three digits, e.g.
 - AMW**004** – Wi-Fi module, Wallaby family, low power **004** model
 - AMW**006** – Wi-Fi module, Numbat family, ultra-low power **006** model
 - AMW**106** – Wi-Fi module, Numbat family, ultra-low power **106** model
 - AMS**001** – Bluetooth module, Bobcat family, LP (low power) **001** model
- **Board Type**
Single character: **E**: Evaluation board, **A**: Adaptor
- **Board Model**
Two digits
- **Revision**
Typically a single digit

10.1 Examples

AMW004 – **M**odule, **W**i-Fi, low power **004** model, Wallaby family

AMW006 – **M**odule, **W**i-Fi, ultra-low power **006** model, Numbat family

AMW106 – **M**odule, **W**i-Fi, ultra-low power **106** model, Numbat family

AMS001 – **M**odule, **S**mart (BLE) LP (low power) **001** model, Bobcat family

AMW004-E03.3 – Wallaby module **E**valuation board, **03** model (Mackerel), revision **3**

AMW006-A02.1 - Numbat 006 module **A**daptor board, **02** model (Mantis), revision **1**

11 Revision History & Glossary

11.1 Revision History

Table 15: Document Revision History

Revision	Date	Change Description
ADS-MW004-100R	Apr 15, 2014	Initial release
ADS-MW004-101R	Apr 28, 2014	Added solder reflow profile; updated throughput & data rate specs
ADS-MW004-102R	Dec 2, 2014	Added antenna certification details, revised for ZentriOS
ADS-MW004-103R	May 6, 2015	Updated ADC and PWM details, updated Table 12, European Compliance Testing
ADS-MW004-104R	Sep 9, 2015	Updated packaging information, updated Table 12, European Compliance Testing
ADS-MW004-104R	Nov 4, 2015	Modified for Zentri re-branding
ADS-MW004-105R	Dec 6, 2016	Added firmware note in Ordering Information section.
ADS-MW004-106R	Aug 29, 2017	Added Firmware Features section, Dimensions section, new Silabs ordering information, updated European Certification

11.2 Glossary

In most cases, acronyms and abbreviations are defined on first use. A comprehensive list of acronyms and other terms used in Zentri documents is provided on the Zentri website at <http://docs.zentri.com/zentri/glossary>.

12 References

Throughout this data sheet, references to other documents are listed. The following documents provide additional material:

1. [IEEE 802.11 Standard](#)
Institute of Electrical and Electronics Engineers.
<http://standards.ieee.org>

Not Recommended for New Design

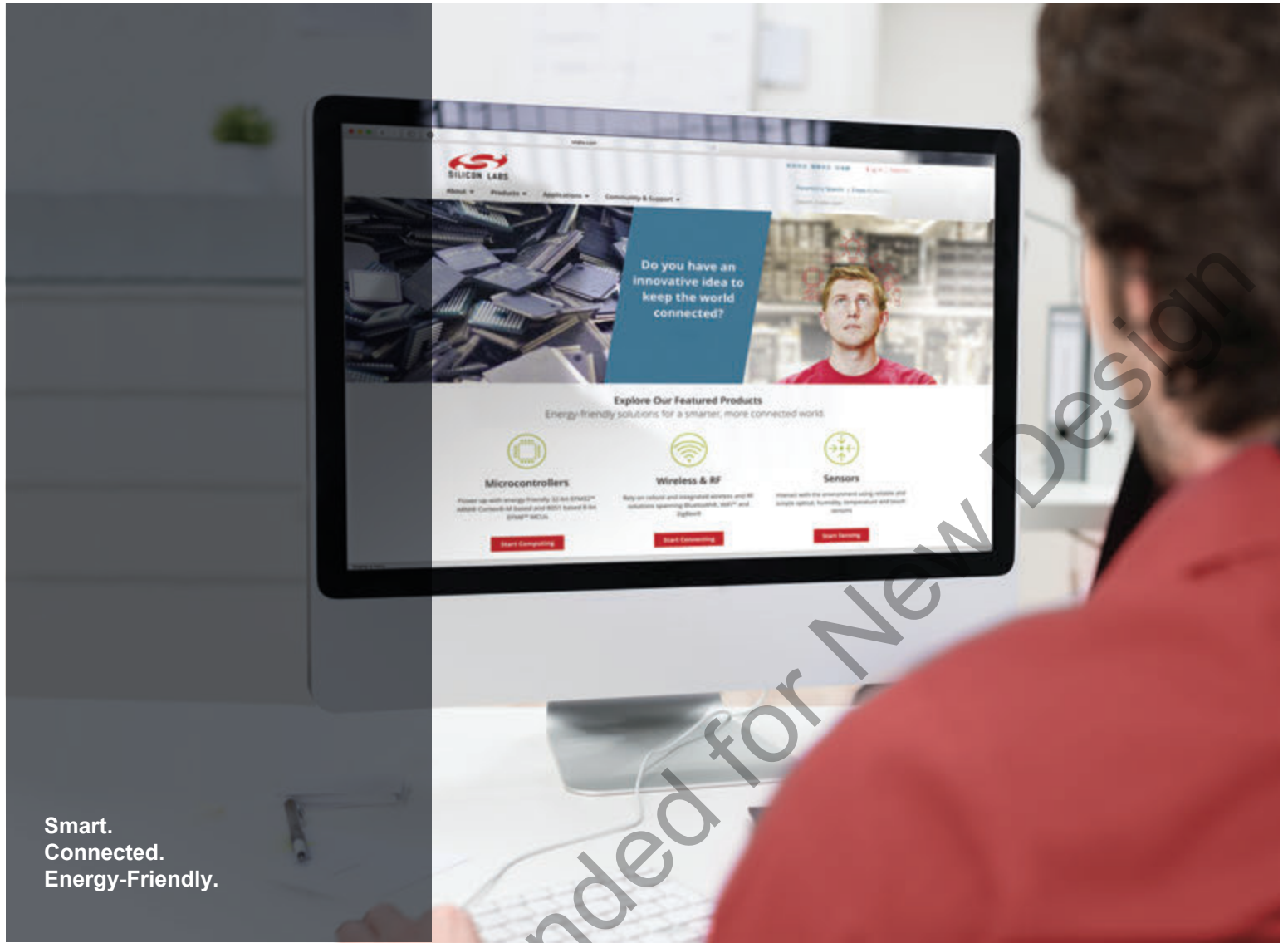

Smart.
Connected.
Energy-Friendly.



Products
www.silabs.com/products



Quality
www.silabs.com/quality



Support and Community
community.silabs.com

Disclaimer

Silicon Labs intends to provide customers with the latest, accurate, and in-depth documentation of all peripherals and modules available for system and software implementers using or intending to use the Silicon Labs products. Characterization data, available modules and peripherals, memory sizes and memory addresses refer to each specific device, and "Typical" parameters provided can and do vary in different applications. Application examples described herein are for illustrative purposes only. Silicon Labs reserves the right to make changes without further notice and limitation to product information, specifications, and descriptions herein, and does not give warranties as to the accuracy or completeness of the included information. Silicon Labs shall have no liability for the consequences of use of the information supplied herein. This document does not imply or express copyright licenses granted hereunder to design or fabricate any integrated circuits. The products are not designed or authorized to be used within any Life Support System without the specific written consent of Silicon Labs. A "Life Support System" is any product or system intended to support or sustain life and/or health, which, if it fails, can be reasonably expected to result in significant personal injury or death. Silicon Labs products are not designed or authorized for military applications. Silicon Labs products shall under no circumstances be used in weapons of mass destruction including (but not limited to) nuclear, biological or chemical weapons, or missiles capable of delivering such weapons.

Trademark Information

Silicon Laboratories Inc.®, Silicon Laboratories®, Silicon Labs®, SiLabs® and the Silicon Labs logo®, Bluegiga®, Bluegiga Logo®, Clockbuilder®, CMEMS®, DSPLL®, EFM®, EFM32®, EFR, Ember®, Energy Micro, Energy Micro logo and combinations thereof, "the world's most energy friendly microcontrollers", Ember®, EZLink®, EZRadio®, EZRadioPRO®, Gecko®, ISOModem®, Micrium, Precision32®, ProSLIC®, Simplicity Studio®, SiPHY®, Telegesis, the Telegesis Logo®, USBXpress®, Zentri and others are trademarks or registered trademarks of Silicon Labs. ARM, CORTEX, Cortex-M3 and THUMB are trademarks or registered trademarks of ARM Holdings. Keil is a registered trademark of ARM Limited. All other products or brand names mentioned herein are trademarks of their respective holders.



SILICON LABS

Silicon Laboratories Inc.
400 West Cesar Chavez
Austin, TX 78701
USA

<http://www.silabs.com>

X-ON Electronics

Largest Supplier of Electrical and Electronic Components

Click to view similar products for [WiFi Modules - 802.11 category](#):

Click to view products by [Silicon Labs manufacturer](#):

Other Similar products are found below :

[KBPC10/15/2506WP](#) [WIFI-RT5392-SB-R10](#) [SX-PCEAN2C-SP](#) [849WM520100E](#) [WIFI-AT2350](#) [7265.NGWG.SW](#) [HDG204-DN-3](#) [FXX-3061-MIX](#) [EMIO-1533-00A2](#) [7265.NGWWB.W](#) [PPC-WL-KIT02-R11](#) [RC-CC2640-B](#) [HLK-7688A](#) [E70-433T14S](#) [WH-NB73-BA](#) [NF-02-PA](#) [EAR00364](#) [ATSAMW25H18-MR210PB1961](#) [3168.NGWG](#) [MY-WF003U](#) [AX210.NGWG.NV](#) [ESP-15F32Mbit](#) [ESP32-S32Mb](#) [TG-01M](#) [ESP-13](#) [ESP-01F-2M](#) [ESP-01E-2M](#) [ESP-12S-8285-2M](#) [ESP-20](#) [ESP32-SL](#) [ESP-12K-PSRAM](#) [ESP-12K](#) [ESP-12K-PSRAM-IPEX](#) [ESP-12H](#) [BW18](#) [BW12-16Mb](#) [BW14](#) [BW15](#) [BW16](#) [TG-12F](#) [SIM7600CE-L1S](#) [CB3S\(tjrl\)](#) [CB3S\(hvk9\)](#) [CB3S\(qh6\)](#) [WB2S\(csyd\)](#) [WB3S\(ppty\)](#) [WB3S\(h238\)](#) [WB3S\(uvmz\)](#) [1005869](#) [1012](#)