

# UG550: BB50 Explorer Kit User's Guide



The BB50 Explorer Kit is an ultra-low cost, small form factor development and evaluation platform for the EFM8BB50 Busy Bee 8-bit microcontroller.

The BB50 Explorer Kit is focused on rapid prototyping and concept creation of multi-purpose applications. It is designed around the EFM8BB50 MCU, which is an ideal device family for developing energy-friendly embedded applications.

The kit features a USB interface, an on-board SEGGER J-Link debugger, one user-LED and button, and support for hardware add-on boards via a mikroBUS™ socket and a Qwiic® connector. The hardware add-on support allows developers to create and prototype applications using a virtually endless combination of off-the-shelf boards from mikroE, sparkfun, AdaFruit, and Seeed Studios.



## TARGET DEVICE

- EFM8BB50 Busy Bee 8-bit microcontroller (EFM8BB50F16I-A-QFN16)
- Pipelined 8-bit C8051 core with 50 MHz maximum operating frequency
- 16 kB flash and 512 bytes RAM

## KIT FEATURES

- User LED and push button
- 2.54 mm breakout pads
- mikroBUS™ socket
- Qwiic® connector
- SEGGER J-Link on-board debugger
- Virtual COM port
- USB-powered

## SOFTWARE SUPPORT

- Simplicity Studio™

## ORDERING INFORMATION

- BB50-EK2702A

# Table of Contents

<b>1. Introduction</b>	<b>3</b>
1.1 Kit Contents	3
1.2 Getting Started	3
1.3 Hardware Content	3
1.4 Kit Hardware Layout	4
<b>2. Specifications</b>	<b>5</b>
2.1 Recommended Operating Conditions	5
2.2 Current Consumption	5
<b>3. Hardware</b>	<b>6</b>
3.1 Block Diagram	6
3.2 Power Supply	7
3.3 EFM8BB50 Reset	7
3.4 Push Button and LED	7
3.5 On-board Debugger	8
3.6 Connectors	8
3.6.1 Breakout Pads	9
3.6.2 MikroBUS Socket	10
3.6.3 Qwiic Connector	11
3.6.4 Debug USB Micro-B Connector	11
<b>4. Debugging</b>	<b>12</b>
4.1 On-board Debugger	12
4.2 Virtual COM Port	12
<b>5. Schematics, Assembly Drawings, and BOM</b>	<b>13</b>
<b>6. Kit Revision History and Errata</b>	<b>14</b>
6.1 Revision History	14
6.2 Errata	14
<b>7. Board Revision History and Errata</b>	<b>15</b>
7.1 Revision History	15
7.2 Errata	15
<b>8. Document Revision History</b>	<b>16</b>

## 1. Introduction

The BB50 Explorer Kit has been designed to inspire customers to explore the Silicon Labs EFM8BB50 Busy Bee 8-bit microcontroller. The kit includes a mikroBUS™ socket and Qwiic® connector, allowing users to add features to the kit with a large selection of off-the-shelf boards.

Programming the BB50 Explorer Kit is easily done using a USB Micro-B cable and the on-board J-Link debugger. A USB virtual COM port provides a serial connection to the target application. The BB50 Explorer Kit is supported in Simplicity Studio™ and a Board Support Package (BSP) is provided to give application developers a flying start.

Connecting external hardware to the BB50 Explorer Kit can be done using the breakout pads which present peripherals from the EFM8BB50 Busy Bee such as I<sup>2</sup>C, SPI, UART, and GPIOs. The mikroBUS socket allows inserting mikroBUS add-on boards which interface with the EFM8BB50 through SPI, UART, or I<sup>2</sup>C. The Qwiic connector can be used to connect hardware from the Qwiic Connect System through I<sup>2</sup>C.

### 1.1 Kit Contents

The following items are included in the box:

- 1x BB50 Explorer Kit board (BRD2702A)

### 1.2 Getting Started

Detailed instructions for how to get started with your new BB50 Explorer Kit can be found on the Silicon Labs web pages:

[silabs.com/dev-tools](https://silabs.com/dev-tools)

### 1.3 Hardware Content

The following key hardware elements are included on the BB50 Explorer Kit:

- EFM8BB50 Busy Bee MCU with 50 MHz operating frequency, 16 kB flash, and 512 bytes RAM
- One LED and one push button
- On-board SEGGER J-Link debugger for easy programming and debugging, which includes a USB virtual COM port
- MikroBUS™ socket for connecting Click boards™ and other mikroBUS add-on boards
- Qwiic® connector for connecting Qwiic Connect System hardware
- Breakout pads for GPIO access and connection to external hardware
- Reset button

### 1.4 Kit Hardware Layout

The layout of the BB50 Explorer Kit is shown below.

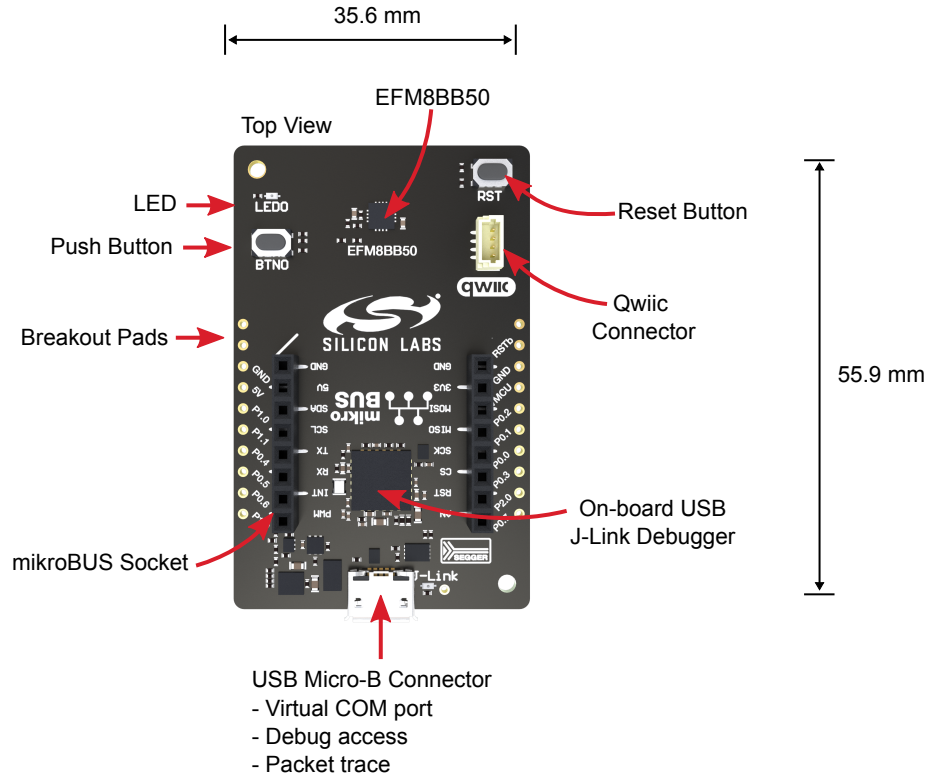

Figure 1.1. BB50 Explorer Kit Hardware Layout

## 2. Specifications

### 2.1 Recommended Operating Conditions

Parameter	Symbol	Min	Typ	Max	Unit
USB Supply Input Voltage	$V_{USB}$	—	5.0	—	V
Supply Input Voltage (VMCU supplied externally) <sup>1, 2</sup>	$V_{VMCU}$	1.8	3.3	3.6	V
Operating Temperature	$T_{OP}$	—	20	—	°C

- 1 Not recommended for use with rechargeable Lithium batteries. Most Li-Ion and Li-Po cells exceed 3.6 V when fully charged.
- 2 When using the provided interfaces with add-on boards or other external hardware, tighter voltage limits might apply.

### 2.2 Current Consumption

The operating current of the board greatly depends on the application and the amount of external hardware connected. The table below attempts to give some indication of typical current consumptions for the EFM8BB50 and the on-board debugger. Note that the numbers are taken from the data sheets for the devices. For a full overview of the conditions that apply for a specific number from a data sheet, the reader is encouraged to read the specific data sheet.

**Table 2.1. Current Consumption**

Parameter	Symbol	Condition	Typ	Unit
EFM8BB50 Current Consumption <sup>1</sup>	$I_{BB}$	MCU current consumption in NORMAL mode (module supply voltage = 3.3 V, $f_{SYSCLK}$ = 49 MHz using HFOSC, $T_{AMB}$ 25 °C)	2.79	mA
		MCU current consumption in SNOOZE mode (module supply voltage = 3.3 V, LFOSC running at 80 kHz, $T_{AMB}$ 25 °C)	9.3	µA
		MCU current consumption in SHUTDOWN mode (module supply voltage = 3.3 V, $T_{AMB}$ 25 °C)	0.24	µA
On-board Debugger Sleep Current Consumption <sup>2</sup>	$I_{DBG}$	On-board debugger current consumption when USB cable is not inserted (EFM32GG12 EM4S mode current consumption)	80	nA

- 1 From EFM8BB50 data sheet.
- 2 From EFM32GG12 data sheet.

### 3. Hardware

The core of the BB50 Explorer Kit is the EFM8BB50 Busy Bee 8-bit microcontroller. Refer to section 1.4 [Kit Hardware Layout](#) for placement and layout of the hardware components.

#### 3.1 Block Diagram

An overview of the BB50 Explorer Kit is illustrated in the figure below.

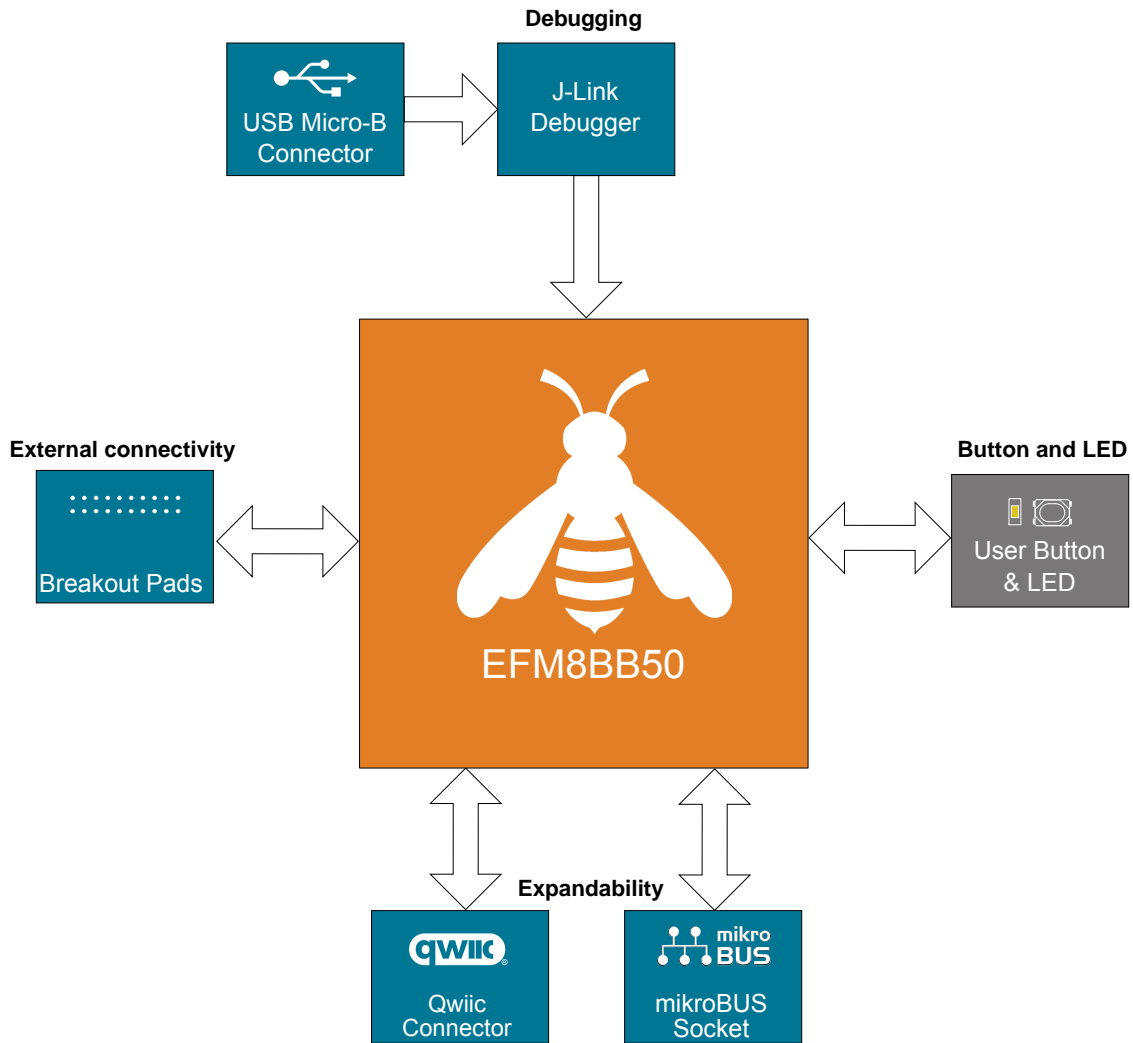
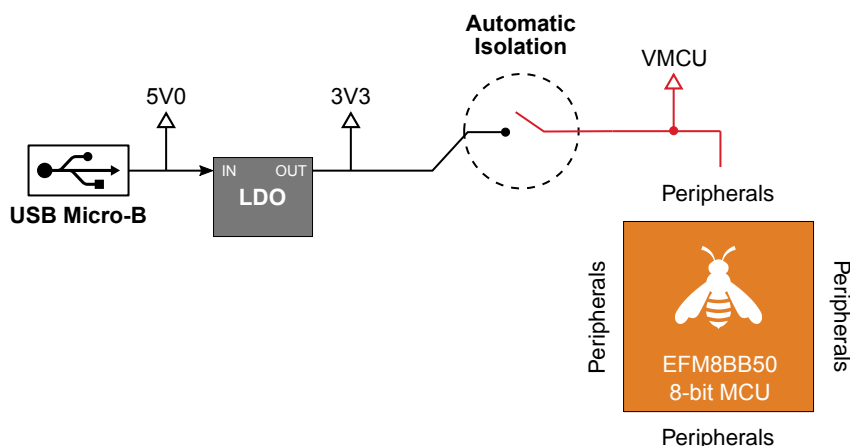

Figure 3.1. Kit Block Diagram

### 3.2 Power Supply

The kit is powered by the debug USB cable as illustrated in the figure below.



**Figure 3.2. BB50 Explorer Kit Power Topology**

The 5 volt power net on the USB bus is regulated down to 3.3 V using a low dropout regulator (LDO). An automatic isolation circuit isolates the LDO when the USB cable is not plugged in.

Power can be injected externally on the VMCU net if the USB cable is removed and no other power sources are present on the kit. Failure to follow this guideline can cause power conflicts and damage the LDO.

### 3.3 EFM8BB50 Reset

The EFM8BB50 can be reset by a few different sources:

- A user pressing the RESET button.
- The on-board debugger pulling the #RESET pin low.

### 3.4 Push Button and LED

The kit has one user push button, marked BTN0, that is connected to a GPIO on the EFM8BB50. The button is connected to pin P0.7 and it is debounced by an RC filter with a time constant of 1 ms. The logic state of the button is high while the button is not being pressed, and low when the button is pressed.

The kit also features one yellow LED, marked LED0, that is controlled by a GPIO pin on the EFM8BB50. The LED is connected to pin P1.2 in an active-high configuration.

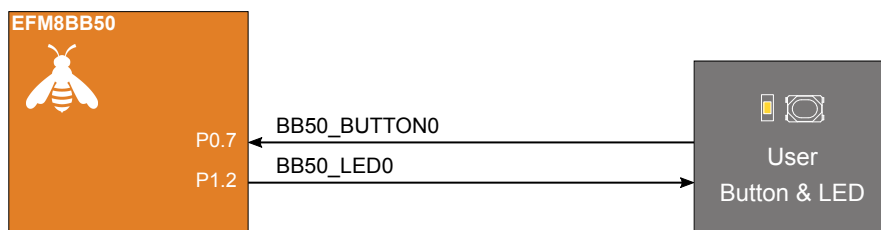

**Figure 3.3. Button and LED**

### 3.5 On-board Debugger

The BB50 Explorer Kit contains a microcontroller separate from the EFM8BB50 Busy Bee that provides the user with an on-board J-Link debugger through the USB Micro-B port. This microcontroller is referred to as the "on-board debugger", and is not programmable by the user. When the USB cable is removed, the on-board debugger goes into a very low power shutoff mode (EM4S).

In addition to providing code download and debug features, the on-board debugger also presents a virtual COM port for general purpose application serial data transfer.

The figure below shows the connections between the target EFM8BB50 device and the on-board debugger. The figure also shows the presence of the Mini Simplicity Connector, and how this is connected to the same I/O pins.

Refer to chapter 4. [Debugging](#) for more details on debugging.

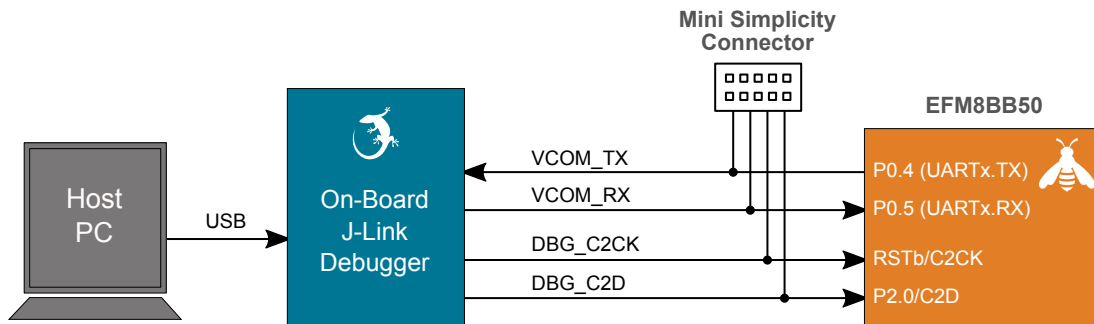

Figure 3.4. On-Board Debugger Connections

### 3.6 Connectors

The BB50 Explorer Kit features a USB Micro-B connector, breakout pads, a mikroBUS connector for connecting mikroBUS add-on boards, and a Qwiic connector for connecting Qwiic Connect System hardware. The connectors are placed on the top side of the board, and their placement and pinout are shown in the figure below. For additional information on the connectors, see the following sub chapters.

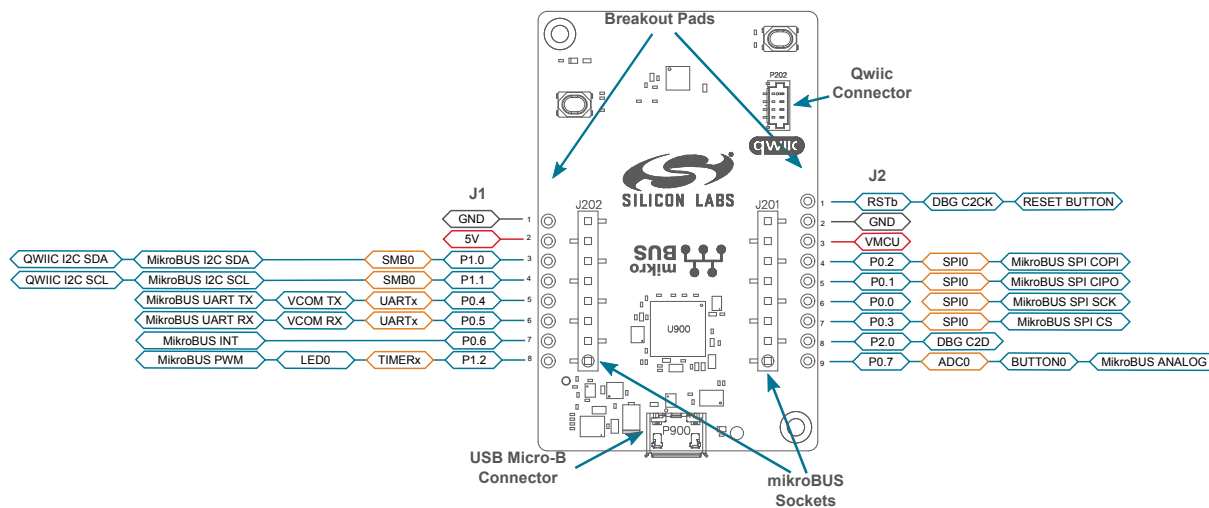

Figure 3.5. BB50 Explorer Kit Connectors



### 3.6.1 Breakout Pads

Seventeen breakout pads are provided and allow connection of external peripherals. The breakout pads are arranged in two rows and contain a number of I/O pins that can be used with most of the EFM8BB50 Busy Bee's features. Additionally, the VMCU (main board power rail), 3V3 (LDO regulator output), and 5V power rails are also exposed on the pads.

The pin-routing on the Busy Bee is flexible, so most peripherals can be routed to any pin on port 1 or 2. However, pins may be shared between the breakout pads and other functions on the BB50 Explorer Kit. The figure in section 3.6 Connectors includes an overview of the breakout pads and functionality that is shared with the kit.

**Table 3.1. Breakout Pads Pinout**

Pin	Connection	Shared Feature
<b>Left-side Breakout Pins</b>		
1	GND	Ground
2	5V	Board USB voltage
3	P1.0	MikroBUS I2C_SDA, Qwiic I2C_SDA
4	P1.1	MikroBUS I2C_SCL, Qwiic I2C_SCL
5	P0.4	VCOM_TX, MicroBUS UART_TX
6	P0.5	VCOM_RX, MicroBUS UART_RX
7	P0.6	MikroBUS INT
8	P1.2	LED0, MikroBUS PWM
<b>Right-side Breakout Pins</b>		
1	RSTb	EFM8BB50 reset, active low
2	GND	Ground
3	VMCU	EFM8BB50 voltage domain
4	P0.2	MikroBUS SPI_COPI
5	P0.1	MikroBUS SPI_CIPO
6	P0.0	MikroBUS SPI_SCK
7	P0.3	MikroBUS SPI_CS
8	P2.0	DBG C2D
9	P0.7	BUTTON0, MikroBUS Analog

### 3.6.2 MikroBUS Socket

The BB50 Explorer Kit features a mikroBUS™ socket compatible with mikroBUS add-on boards. MikroBUS add-on boards can expand the functionality of the kit with peripherals such as sensors and LCDs. Add-on boards follow the mikroBUS socket pin mapping, and communicate with the on-kit EFM8BB50 through UART, SPI, or I<sup>2</sup>C. Several GPIOs are exposed on the mikroBUS socket. MikroBUS add-on boards can be powered by the 5V or VMCU power rails, which are available on the mikroBUS socket.

The pinout of the EFM8BB50 on the kit is made such that all required peripherals are available on the mikroBUS socket. The I<sup>2</sup>C signals are, however, shared with the Qwiic connector, and all mikroBUS signals are also routed to adjacent breakout pads.

When inserting a mikroBUS add-on board, refer to the orientation notch on the BB50 Explorer Kit, shown in the figure below, to ensure correct orientation. Add-on boards have a similar notch that needs to be lined up with the one shown below.

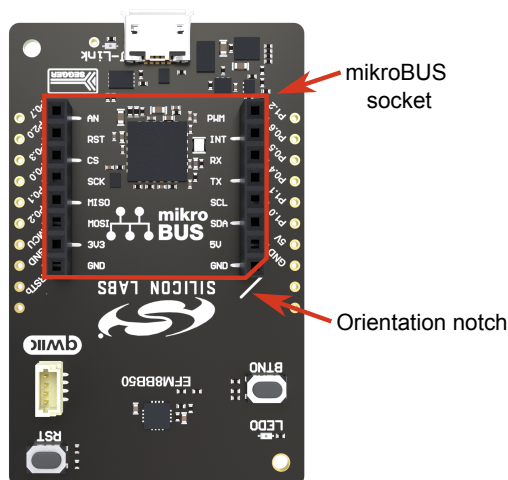

**Figure 3.6. mikroBUS Add-on Board Orientation**

The table below gives an overview of the mikroBUS socket pin connections to the EFM8BB50.

**Table 3.2. mikroBUS Socket Pinout**

mikro-BUS Pin Name	mikroBUS Pin Function	Connection	Shared Feature	Suggested Peripheral Mapping
AN	Analog	P0.7	BREAKOUT_RIGHT9	ADC0.CH1
RST	Reset	P2.0	BREAKOUT_RIGHT8	
CS	SPI Chip Select	P0.3	BREAKOUT_RIGHT7	SPI0.NSS
SCK	SPI Clock	P0.0	BREAKOUT_RIGHT6	SPI0.SCK
MISO	SPI Main Input Secondary Output	P0.1	BREAKOUT_RIGHT5	SPI0.CIPO
MOSI	SPI Main Output Secondary Input	P0.2	BREAKOUT_RIGHT4	SPI0.COPI
PWM	PWM output	P1.2	BREAKOUT_LEFT8	TIMERx.Tx
INT	Hardware Interrupt	P0.6	BREAKOUT_LEFT7	
RX	UART Receive	P0.5	VCOM_RX, BREAKOUT_LEFT6	UARTx.RX
TX	UART Transmit	P0.4	VCOM_TX, BREAKOUT_LEFT5	UARTx.TX
SCL	I2C Clock	P1.1	QWIIC_I2C_SCL, BREAKOUT_LEFT4	SMB0.SCL
SDA	I2C Data	P1.0	QWIIC_I2C_SDA, BREAKOUT_LEFT3	SMB0.SDA

mikro-BUS Pin Name	mikroBUS Pin Function	Connection	Shared Feature	Suggested Peripheral Mapping
3V3	VCC 3.3V power	VMCU	EFM8BB50 voltage domain	—
5V	VCC 5V power	5V	Board USB voltage	—
GND	Reference Ground	GND	Ground	—

### 3.6.3 Qwiic Connector

The BB50 Explorer Kit features a Qwiic® connector compatible with Qwiic Connect System hardware. The Qwiic connector provides an easy way to expand the functionality of the BB50 Explorer Kit with sensors, LCDs, and other peripherals over the I<sup>2</sup>C interface. The Qwiic connector is a 4-pin polarized JST connector, which ensures the cable is inserted the right way.

Qwiic Connect System hardware is daisy chain-able as long as each I<sup>2</sup>C device in the chain has a unique I<sup>2</sup>C address.

**Note:** The Qwiic I<sup>2</sup>C connections on the BB50 Explorer Kit are shared with the mikroBUS I<sup>2</sup>C signals.

The Qwiic connector and its connections to Qwiic cables and the EFM8BB50 are illustrated in the figure below.

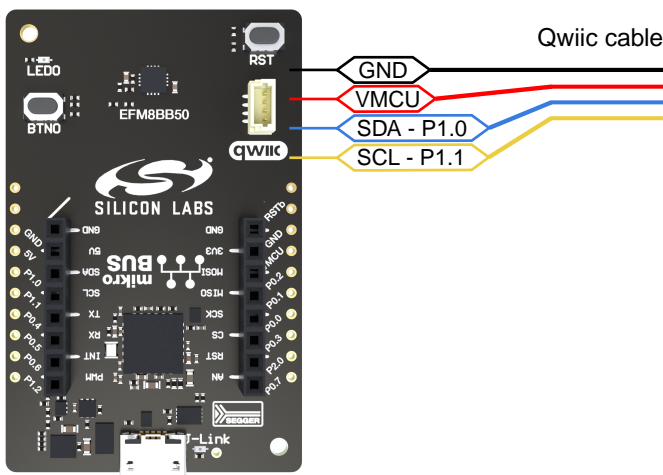

Figure 3.7. Qwiic Connector

The table below gives an overview of the Qwiic connections to the EFM8BB50.

Table 3.3. Qwiic Connector Pinout

Qwiic Pin	Connection	Shared Feature	Suggested Peripheral Mapping
Ground	GND	Ground	—
3.3V	VMCU	EFM8BB50 voltage domain	—
SDA	P1.0	MIKROE_I2C_SDA, BREAKOUT_LEFT3	SMB0.SDA
SCL	P1.1	MIKROE_I2C_SCL, BREAKOUT_LEFT4	SMB0.SCL

### 3.6.4 Debug USB Micro-B Connector

The debug USB port can be used for uploading code, debugging, and as a virtual COM port. More information is available in section 4. Debugging.

## 4. Debugging

The BB50 Explorer Kit contains an on-board SEGGER J-Link Debugger that is connected to the C2 debugging interface on the EFM8BB50. The debugger allows the user to download code and debug applications running in the target EFM8BB50. Additionally, it also provides a virtual COM port (VCOM) to the host computer that is connected to the target device's serial port for general purpose communication between the running application and the host computer. The on-board debugger is accessible through the USB Micro-B connector.

### 4.1 On-board Debugger

The on-board debugger is a SEGGER J-Link debugger running on an EFM32 Giant Gecko. The debugger is directly connected to the debug and VCOM pins of the target EFM8BB50.

When the debug USB cable is inserted, the on-board debugger is automatically active, and takes control of the debug and VCOM interfaces. This means that debug and communication will *not* work with an external debugger connected at the same time. The on-board LDO is also activated, providing power to the board.

When the USB cable is removed, the board might still be running on external power, as described in section [3.2 Power Supply](#). In this case, the on-board debugger goes into a very low power shutoff mode (EM4S), consuming about 80 nA.

### 4.2 Virtual COM Port

The virtual COM port is a connection to a UART of the target EFM8BB50 and allows serial data to be sent and received from the device. The on-board debugger presents the target UART as a virtual COM port on the host computer that shows up when the USB cable is inserted.

Data is transferred between the host computer and the debugger through the USB connection, which emulates a serial port using the USB Communication Device Class (CDC). From the debugger, the data is passed on to the target device through a physical UART connection.

The serial format is 115200 bps, 8 bits, no parity, and 1 stop bit by default.

**Note:** Changing the baud rate for the COM port on the PC side does not influence the UART baud rate between the debugger and the target device.

## 5. Schematics, Assembly Drawings, and BOM

Schematics, assembly drawings, and bill of materials (BOM) are available through Simplicity Studio when the kit documentation package has been installed. They are also available from the kit page on the Silicon Labs website: [silabs.com](https://silabs.com).

## 6. Kit Revision History and Errata

### 6.1 Revision History

The kit revision can be found printed on the box label of the kit, as outlined in the figure below. The kit revision history is summarized in the table below.

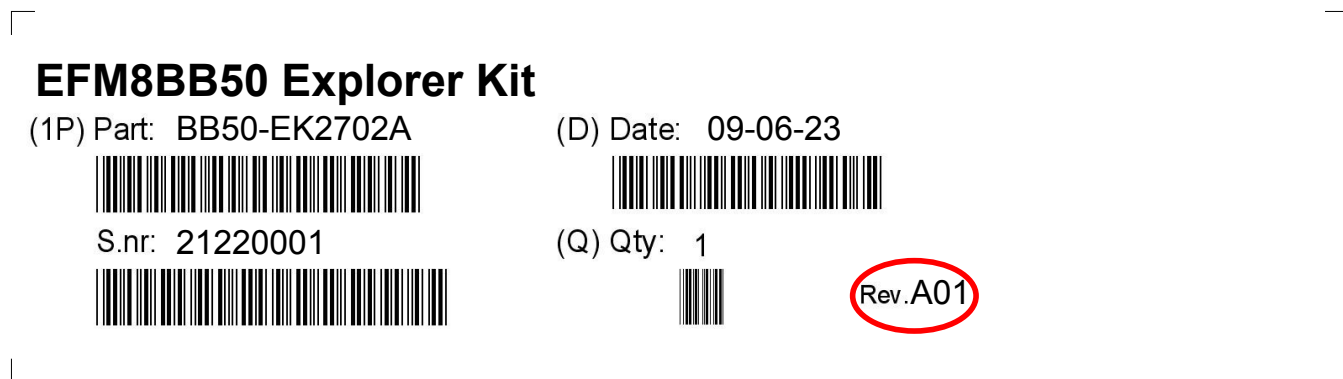

Figure 6.1. Revision Info

Table 6.1. Kit Revision History

Kit Revision	Released	Description
A01	9 June 2023	Initial kit version.

### 6.2 Errata

There are no known errata at present.

## 7. Board Revision History and Errata

### 7.1 Revision History

The board revision can be found laser printed on the board, and the board revision history is summarized in the following table.

**Table 7.1. Board Revision History**

Revision	Released	Description
A01	9 June 2023	Initial version.

### 7.2 Errata

There are no known errata at present.

## 8. Document Revision History

### Revision 1.0

June 2023

- Initial document release.



# Simplicity Studio

One-click access to MCU and wireless tools, documentation, software, source code libraries & more. Available for Windows, Mac and Linux!



**IoT Portfolio**  
[www.silabs.com/IoT](http://www.silabs.com/IoT)



**SW/HW**  
[www.silabs.com/simplicity](http://www.silabs.com/simplicity)



**Quality**  
[www.silabs.com/quality](http://www.silabs.com/quality)



**Support & Community**  
[www.silabs.com/community](http://www.silabs.com/community)

## Disclaimer

Silicon Labs intends to provide customers with the latest, accurate, and in-depth documentation of all peripherals and modules available for system and software implementers using or intending to use the Silicon Labs products. Characterization data, available modules and peripherals, memory sizes and memory addresses refer to each specific device, and "Typical" parameters provided can and do vary in different applications. Application examples described herein are for illustrative purposes only. Silicon Labs reserves the right to make changes without further notice to the product information, specifications, and descriptions herein, and does not give warranties as to the accuracy or completeness of the included information. Without prior notification, Silicon Labs may update product firmware during the manufacturing process for security or reliability reasons. Such changes will not alter the specifications or the performance of the product. Silicon Labs shall have no liability for the consequences of use of the information supplied in this document. This document does not imply or expressly grant any license to design or fabricate any integrated circuits. The products are not designed or authorized to be used within any FDA Class III devices, applications for which FDA premarket approval is required or Life Support Systems without the specific written consent of Silicon Labs. A "Life Support System" is any product or system intended to support or sustain life and/or health, which, if it fails, can be reasonably expected to result in significant personal injury or death. Silicon Labs products are not designed or authorized for military applications. Silicon Labs products shall under no circumstances be used in weapons of mass destruction including (but not limited to) nuclear, biological or chemical weapons, or missiles capable of delivering such weapons. Silicon Labs disclaims all express and implied warranties and shall not be responsible or liable for any injuries or damages related to use of a Silicon Labs product in such unauthorized applications.

**Note: This content may contain offensive terminology that is now obsolete. Silicon Labs is replacing these terms with inclusive language wherever possible. For more information, visit [www.silabs.com/about-us/inclusive-lexicon-project](http://www.silabs.com/about-us/inclusive-lexicon-project)**

## Trademark Information

Silicon Laboratories Inc.<sup>®</sup>, Silicon Laboratories<sup>®</sup>, Silicon Labs<sup>®</sup>, SiLabs<sup>®</sup> and the Silicon Labs logo<sup>®</sup>, Bluegiga<sup>®</sup>, Bluegiga Logo<sup>®</sup>, EFM<sup>®</sup>, EFM32<sup>®</sup>, EFR, Ember<sup>®</sup>, Energy Micro, Energy Micro logo and combinations thereof, "the world's most energy friendly microcontrollers", Redpine Signals<sup>®</sup>, WiSeConnect, n-Link, ThreadArch<sup>®</sup>, EZLink<sup>®</sup>, EZRadio<sup>®</sup>, EZRadioPRO<sup>®</sup>, Gecko<sup>®</sup>, Gecko OS, Gecko OS Studio, Precision32<sup>®</sup>, Simplicity Studio<sup>®</sup>, Telegesis, the Telegesis Logo<sup>®</sup>, USBXpress<sup>®</sup>, Zentri, the Zentri logo and Zentri DMS, Z-Wave<sup>®</sup>, and others are trademarks or registered trademarks of Silicon Labs. ARM, CORTEX, Cortex-M3 and THUMB are trademarks or registered trademarks of ARM Holdings. Keil is a registered trademark of ARM Limited. Wi-Fi is a registered trademark of the Wi-Fi Alliance. All other products or brand names mentioned herein are trademarks of their respective holders.



Silicon Laboratories Inc.  
400 West Cesar Chavez  
Austin, TX 78701  
USA

[www.silabs.com](http://www.silabs.com)

## X-ON Electronics

Largest Supplier of Electrical and Electronic Components

*Click to view similar products for [Development Boards & Kits - 8051 category](#):*

*Click to view products by [Silicon Labs manufacturer](#):*

Other Similar products are found below :

[C8051F360-TB-K](#) [C8051F310DK](#) [C8051F390-A-DK](#) [C8051F930-TB-K](#) [C8051F850-B-DK](#) [CY8CKIT-030A](#) [AT85RFD-07](#) [MIKROE-2018](#)  
[MIKROE-2019](#) [MIKROE-257](#) [MIKROE-598](#) [PIM447](#) [BB50-EK2702A](#) [BB50-PK5208A](#) [BB51-EK2700A](#) [BB52-EK2701A](#) [C8051F020DK](#)  
[C8051F120DK](#) [C8051F330DK](#) [C8051F350DK](#) [C8051F350-TB-K](#) [C8051F380DK](#) [C8051F380-TB-K](#) [C8051F410DK](#) [C8051F500DK](#)  
[C8051F540DK](#) [C8051F560DK](#) [C8051F560-TB-K](#) [C8051F580DK](#) [C8051F912DK](#) [C8051F930DK](#) [C8051F970-A-DK](#) [C8051F996DK](#)  
[C8051F996-TB](#) [C8051F996-TB-K](#) [EFM8BB1LCK](#) [F990SLIDEREK](#) [MCUNIVERSITYKIT](#) [SLBLDC-MTR-RD](#) [SLSTK2010A](#)