

### Analog Peripherals

- **10-Bit ADC ('F330/2/4 only)**
  - Up to 200 ksp/s
  - Up to 16 external single-ended or differential inputs
  - VREF from internal VREF, external pin or V<sub>DD</sub>
  - Internal or external start of conversion source
  - Built-in temperature sensor
- **10-Bit Current Output DAC ('F330 only)**
- **Comparator**
  - Programmable hysteresis and response time
  - Configurable as interrupt or reset source
  - Low current (0.4 μA)

### On-Chip Debug

- On-chip debug circuitry facilitates full speed, non-intrusive in-system debug (no emulator required)
- Provides breakpoints, single stepping, inspect/modify memory and registers
- Superior performance to emulation systems using ICE-chips, target pods, and sockets
- Low cost, **complete** development kit

### Supply Voltage 2.7 to 3.6 V

- Typical operating current: 6.4 mA at 25 MHz;  
9 μA at 32 kHz
- Typical stop mode current: 0.1 μA

**Temperature Range: -40 to +85 °C**

### High Speed 8051 μC Core

- Pipelined instruction architecture; executes 70% of instructions in 1 or 2 system clocks
- Up to 25 MIPS throughput with 25 MHz clock
- Expanded interrupt handler

### Memory

- 768 bytes internal data RAM (256 + 512)
- 8 kB ('F330/1), 4 kB ('F332/3), or 2 kB ('F334/5) Flash; In-system programmable in 512-byte Sectors—512 bytes are reserved in the 8 kB devices

### Digital Peripherals

- 17 Port I/O; All 5 V tolerant with high sink current
- Hardware enhanced UART, SMBus™, and enhanced SPI™ serial ports
- Four general purpose 16-bit counter/timers
- 16-Bit programmable counter array (PCA) with three capture/compare modules
- Real time clock mode using PCA or timer and external clock source

### Clock Sources

- Two internal oscillators:
  - 24.5 MHz with ±2% accuracy supports crystal-less UART operation
  - 80/40/20/10 kHz low frequency, low power
- External oscillator: Crystal, RC, C, or clock (1 or 2 pin modes)
- Can switch between clock sources on-the-fly; useful in power saving modes

### 20-Pin QFN Package

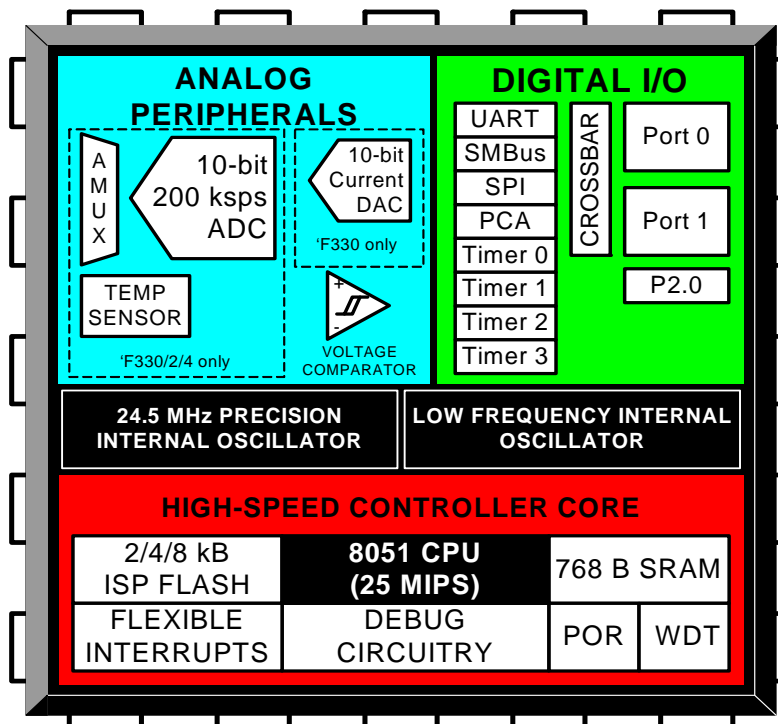

# C8051F330/1/2/3/4/5

---

---

## Table of Contents

<b>1. System Overview</b>	<b>17</b>
1.1. CIP-51™ Microcontroller Core	22
1.1.1. Fully 8051 Compatible	22
1.1.2. Improved Throughput	22
1.1.3. Additional Features	23
1.2. On-Chip Memory	24
1.3. On-Chip Debug Circuitry	25
1.4. Programmable Digital I/O and Crossbar	26
1.5. Serial Ports	26
1.6. Programmable Counter Array	27
1.7. 10-Bit Analog to Digital Converter	28
1.8. Comparators	29
1.9. 10-bit Current Output DAC	30
<b>2. Absolute Maximum Ratings</b>	<b>31</b>
<b>3. Global Electrical Characteristics</b>	<b>32</b>
<b>4. Pinout and Package Definitions</b>	<b>35</b>
<b>5. 10-Bit ADC (ADC0, C8051F330/2/4 only)</b>	<b>41</b>
5.1. Analog Multiplexer	41
5.2. Temperature Sensor	42
5.3. Modes of Operation	43
5.3.1. Starting a Conversion	44
5.3.2. Tracking Modes	45
5.3.3. Settling Time Requirements	46
5.4. Programmable Window Detector	51
5.4.1. Window Detector In Single-Ended Mode	53
5.4.2. Window Detector In Differential Mode	54
<b>6. 10-Bit Current Mode DAC (IDA0, C8051F330 only)</b>	<b>57</b>
6.1. IDA0 Output Scheduling	57
6.1.1. Update Output On-Demand	57
6.1.2. Update Output Based on Timer Overflow	58
6.1.3. Update Output Based on CNVSTR Edge	58
6.2. IDAC Output Mapping	58
<b>7. Voltage Reference (C8051F330/2/4 only)</b>	<b>61</b>
<b>8. Comparator0</b>	<b>65</b>
<b>9. CIP-51 Microcontroller</b>	<b>71</b>
9.1. Instruction Set	72
9.1.1. Instruction and CPU Timing	72
9.1.2. MOVX Instruction and Program Memory	72
9.2. Memory Organization	76
9.2.1. Program Memory	77
9.2.2. Data Memory	78
9.2.3. General Purpose Registers	78
9.2.4. Bit Addressable Locations	78

# C8051F330/1/2/3/4/5

---

9.2.5. Stack .....	78
9.2.6. Special Function Registers.....	79
9.2.7. Register Descriptions .....	83
9.3. Interrupt Handler .....	85
9.3.1. MCU Interrupt Sources and Vectors .....	86
9.3.2. External Interrupts .....	87
9.3.3. Interrupt Priorities .....	87
9.3.4. Interrupt Latency .....	87
9.3.5. Interrupt Register Descriptions.....	89
9.4. Power Management Modes .....	94
9.4.1. Idle Mode.....	94
9.4.2. Stop Mode .....	95
<b>10. Reset Sources.....</b>	<b>97</b>
10.1. Power-On Reset .....	98
10.2. Power-Fail Reset/VDD Monitor .....	98
10.3. External Reset .....	99
10.4. Missing Clock Detector Reset .....	99
10.5. Comparator0 Reset .....	100
10.6. PCA Watchdog Timer Reset .....	100
10.7. Flash Error Reset .....	100
10.8. Software Reset.....	100
<b>11. Flash Memory .....</b>	<b>103</b>
11.1. Programming The Flash Memory .....	103
11.1.1. Flash Lock and Key Functions .....	103
11.1.2. Flash Erase Procedure .....	103
11.1.3. Flash Write Procedure .....	104
11.2. Non-volatile Data Storage .....	104
11.3. Security Options .....	105
11.4. Flash Write and Erase Guidelines .....	107
11.4.1. $V_{DD}$ Maintenance and the $V_{DD}$ monitor .....	107
11.4.2. PSWE Maintenance .....	107
11.4.3. System Clock .....	108
<b>12. External RAM .....</b>	<b>111</b>
<b>13. Oscillators .....</b>	<b>113</b>
13.1. Programmable Internal High-Frequency (H-F) Oscillator .....	113
13.2. Programmable Internal Low-Frequency (L-F) Oscillator .....	115
13.2.1. Calibrating the Internal L-F Oscillator.....	115
13.3. External Oscillator Drive Circuit.....	116
13.3.1. External Crystal Example.....	118
13.3.2. External RC Example.....	120
13.3.3. External Capacitor Example.....	120
13.4. System Clock Selection.....	121
<b>14. Port Input/Output.....</b>	<b>123</b>
14.1. Priority Crossbar Decoder .....	125
14.2. Port I/O Initialization .....	127

---

---

14.3.General Purpose Port I/O .....	129
<b>15. SMBus .....</b>	<b>135</b>
15.1.Supporting Documents .....	136
15.2.SMBus Configuration.....	136
15.3.SMBus Operation .....	136
15.3.1.Arbitration.....	137
15.3.2.Clock Low Extension.....	138
15.3.3.SCL Low Timeout.....	138
15.3.4.SCL High (SMBus Free) Timeout .....	138
15.4.Using the SMBus.....	138
15.4.1.SMBus Configuration Register.....	140
15.4.2.SMB0CN Control Register .....	143
15.4.3.Data Register .....	146
15.5.SMBus Transfer Modes.....	146
15.5.1.Master Transmitter Mode .....	146
15.5.2.Master Receiver Mode .....	148
15.5.3.Slave Receiver Mode .....	149
15.5.4.Slave Transmitter Mode .....	150
15.6.SMBus Status Decoding.....	150
<b>16. UART0.....</b>	<b>153</b>
16.1.Enhanced Baud Rate Generation.....	154
16.2.Operational Modes .....	155
16.2.1.8-Bit UART .....	155
16.2.2.9-Bit UART .....	156
16.3.Multiprocessor Communications .....	156
<b>17. Enhanced Serial Peripheral Interface (SPI0).....</b>	<b>163</b>
17.1.Signal Descriptions.....	164
17.1.1.Master Out, Slave In (MOSI).....	164
17.1.2.Master In, Slave Out (MISO).....	164
17.1.3.Serial Clock (SCK) .....	164
17.1.4.Slave Select (NSS) .....	164
17.2.SPI0 Master Mode Operation .....	165
17.3.SPI0 Slave Mode Operation .....	167
17.4.SPI0 Interrupt Sources .....	167
17.5.Serial Clock Timing.....	168
17.6.SPI Special Function Registers .....	169
<b>18. Timers.....</b>	<b>177</b>
18.1.Timer 0 and Timer 1 .....	177
18.1.1.Mode 0: 13-bit Counter/Timer .....	177
18.1.2.Mode 1: 16-bit Counter/Timer .....	178
18.1.3.Mode 2: 8-bit Counter/Timer with Auto-Reload.....	179
18.1.4.Mode 3: Two 8-bit Counter/Timers (Timer 0 Only).....	180
18.2.Timer 2 .....	185
18.2.1.16-bit Timer with Auto-Reload.....	185

---

# C8051F330/1/2/3/4/5

---

18.2.2.8-bit Timers with Auto-Reload.....	186
18.3.Timer 3 .....	189
18.3.1.16-bit Timer with Auto-Reload.....	189
18.3.2.8-bit Timers with Auto-Reload.....	190
<b>19. Programmable Counter Array .....</b>	<b>193</b>
19.1.PCA Counter/Timer .....	194
19.2.Capture/Compare Modules .....	195
19.2.1.Edge-triggered Capture Mode.....	196
19.2.2.Software Timer (Compare) Mode.....	197
19.2.3.High-Speed Output Mode .....	198
19.2.4.Frequency Output Mode .....	199
19.2.5.8-Bit Pulse Width Modulator Mode.....	200
19.2.6.16-Bit Pulse Width Modulator Mode.....	201
19.3.Watchdog Timer Mode .....	201
19.3.1.Watchdog Timer Operation .....	202
19.3.2.Watchdog Timer Usage .....	203
19.4.Register Descriptions for PCA.....	204
<b>20. C2 Interface .....</b>	<b>209</b>
20.1.C2 Interface Registers.....	209
20.2.C2 Pin Sharing .....	211

## List of Figures

### 1. System Overview

Figure 1.1. C8051F330 Block Diagram.....	19
Figure 1.2. C8051F331 Block Diagram.....	19
Figure 1.3. C8051F332 Block Diagram.....	20
Figure 1.4. C8051F333 Block Diagram.....	20
Figure 1.5. C8051F334 Block Diagram.....	21
Figure 1.6. C8051F335 Block Diagram.....	21
Figure 1.7. Comparison of Peak MCU Execution Speeds .....	22
Figure 1.8. On-Chip Clock and Reset.....	23
Figure 1.9. On-Board Memory Map .....	24
Figure 1.10. Development/In-System Debug Diagram.....	25
Figure 1.11. Digital Crossbar Diagram .....	26
Figure 1.12. PCA Block Diagram.....	27
Figure 1.13. PCA Block Diagram.....	27
Figure 1.14. 10-Bit ADC Block Diagram.....	28
Figure 1.15. Comparator0 Block Diagram.....	29
Figure 1.16. IDA0 Functional Block Diagram .....	30

### 2. Absolute Maximum Ratings

### 3. Global Electrical Characteristics

### 4. Pinout and Package Definitions

Figure 4.1. QFN-20 Pinout Diagram (Top View).....	37
---	----

### 5. 10-Bit ADC (ADC0, C8051F330/2/4 only)

Figure 5.1. ADC0 Functional Block Diagram .....	41
Figure 5.2. Typical Temperature Sensor Transfer Function .....	43
Figure 5.3. 10-Bit ADC Track and Conversion Example Timing.....	45
Figure 5.4. ADC0 Equivalent Input Circuits .....	46
Figure 5.5. ADC Window Compare Example: Right-Justified Single-Ended Data... 53	
Figure 5.6. ADC Window Compare Example: Left-Justified Single-Ended Data .....	53
Figure 5.7. ADC Window Compare Example: Right-Justified Differential Data .....	54
Figure 5.8. ADC Window Compare Example: Left-Justified Differential Data .....	54

### 6. 10-Bit Current Mode DAC (IDA0, C8051F330 only)

Figure 6.1. IDA0 Functional Block Diagram.....	57
Figure 6.2. IDA0 Data Word Mapping.....	58

### 7. Voltage Reference (C8051F330/2/4 only)

Figure 7.1. Voltage Reference Functional Block Diagram.....	61
---	----

### 8. Comparator0

Figure 8.1. Comparator0 Functional Block Diagram.....	65
Figure 8.2. Comparator Hysteresis Plot.....	66

### 9. CIP-51 Microcontroller

Figure 9.1. CIP-51 Block Diagram .....	71
Figure 9.2. Memory Map.....	77

### 10. Reset Sources

Figure 10.1. Reset Sources.....	97
---------------------------------	----

# C8051F330/1/2/3/4/5

---

Figure 10.2. Power-On and VDD Monitor Reset Timing .....	98
<b>11. Flash Memory</b>	
Figure 11.1. Flash Program Memory Map .....	105
<b>12. External RAM</b>	
<b>13. Oscillators</b>	
Figure 13.1. Oscillator Diagram .....	113
Figure 13.2. External 32.768 kHz Quartz Crystal Oscillator Connection Diagram .	119
<b>14. Port Input/Output</b>	
Figure 14.1. Port I/O Functional Block Diagram .....	123
Figure 14.2. Port I/O Cell Block Diagram .....	124
Figure 14.3. Crossbar Priority Decoder with No Pins Skipped .....	125
Figure 14.4. Crossbar Priority Decoder with Crystal Pins Skipped .....	126
<b>15. SMBus</b>	
Figure 15.1. SMBus Block Diagram .....	135
Figure 15.2. Typical SMBus Configuration .....	136
Figure 15.3. SMBus Transaction .....	137
Figure 15.4. Typical SMBus SCL Generation.....	141
Figure 15.5. Typical Master Transmitter Sequence.....	147
Figure 15.6. Typical Master Receiver Sequence.....	148
Figure 15.7. Typical Slave Receiver Sequence.....	149
Figure 15.8. Typical Slave Transmitter Sequence.....	150
<b>16. UART0</b>	
Figure 16.1. UART0 Block Diagram .....	153
Figure 16.2. UART0 Baud Rate Logic .....	154
Figure 16.3. UART Interconnect Diagram .....	155
Figure 16.4. 8-Bit UART Timing Diagram.....	155
Figure 16.5. 9-Bit UART Timing Diagram.....	156
Figure 16.6. UART Multi-Processor Mode Interconnect Diagram .....	157
<b>17. Enhanced Serial Peripheral Interface (SPI0)</b>	
Figure 17.1. SPI Block Diagram .....	163
Figure 17.2. Multiple-Master Mode Connection Diagram .....	166
Figure 17.3. 3-Wire Single Master and 3-Wire Single Slave Mode Connection Diagram	166
Figure 17.4. 4-Wire Single Master Mode and 4-Wire Slave Mode Connection Diagram	166
Figure 17.5. Master Mode Data/Clock Timing .....	168
Figure 17.6. Slave Mode Data/Clock Timing (CKPHA = 0) .....	169
Figure 17.7. Slave Mode Data/Clock Timing (CKPHA = 1) .....	169
Figure 17.8. SPI Master Timing (CKPHA = 0) .....	173
Figure 17.9. SPI Master Timing (CKPHA = 1) .....	173
Figure 17.10. SPI Slave Timing (CKPHA = 0) .....	174
Figure 17.11. SPI Slave Timing (CKPHA = 1) .....	174
<b>18. Timers</b>	
Figure 18.1. T0 Mode 0 Block Diagram.....	178
Figure 18.2. T0 Mode 2 Block Diagram.....	179

---



---

Figure 18.3. T0 Mode 3 Block Diagram.....	180
Figure 18.4. Timer 2 16-Bit Mode Block Diagram .....	185
Figure 18.5. Timer 2 8-Bit Mode Block Diagram .....	186
Figure 18.6. Timer 3 16-Bit Mode Block Diagram .....	189
Figure 18.7. Timer 3 8-Bit Mode Block Diagram .....	190
<b>19. Programmable Counter Array</b>	
Figure 19.1. PCA Block Diagram.....	193
Figure 19.2. PCA Counter/Timer Block Diagram.....	194
Figure 19.3. PCA Interrupt Block Diagram .....	195
Figure 19.4. PCA Capture Mode Diagram.....	196
Figure 19.5. PCA Software Timer Mode Diagram .....	197
Figure 19.6. PCA High-Speed Output Mode Diagram.....	198
Figure 19.7. PCA Frequency Output Mode .....	199
Figure 19.8. PCA 8-Bit PWM Mode Diagram .....	200
Figure 19.9. PCA 16-Bit PWM Mode.....	201
Figure 19.10. PCA Module 2 with Watchdog Timer Enabled .....	202
<b>20. C2 Interface</b>	
Figure 20.1. Typical C2 Pin Sharing.....	211

# C8051F330/1/2/3/4/5

---

---

## List of Tables

<b>1. System Overview</b>	
Table 1.1. Product Selection Guide .....	18
<b>2. Absolute Maximum Ratings</b>	
Table 2.1. Absolute Maximum Ratings .....	31
<b>3. Global Electrical Characteristics</b>	
Table 3.1. Global Electrical Characteristics .....	32
Table 3.2. Index to Electrical Characteristics Tables .....	34
<b>4. Pinout and Package Definitions</b>	
Table 4.1. Pin Definitions for the C8051F330/1/2/3/4/5 .....	35
Table 4.2. QFN-20 Package Dimensions .....	38
Table 4.3. QFN-20 PCB Land Pattern Dimensions .....	39
<b>5. 10-Bit ADC (ADC0, C8051F330/2/4 only)</b>	
Table 5.1. ADC0 Electrical Characteristics .....	55
<b>6. 10-Bit Current Mode DAC (IDA0, C8051F330 only)</b>	
Table 6.1. IDAC Electrical Characteristics .....	60
<b>7. Voltage Reference (C8051F330/2/4 only)</b>	
Table 7.1. Voltage Reference Electrical Characteristics .....	63
<b>8. Comparator0</b>	
Table 8.1. Comparator Electrical Characteristics .....	70
<b>9. CIP-51 Microcontroller</b>	
Table 9.1. CIP-51 Instruction Set Summary .....	73
Table 9.2. Special Function Register (SFR) Memory Map .....	79
Table 9.3. Special Function Registers .....	80
Table 9.4. Interrupt Summary .....	88
<b>10. Reset Sources</b>	
Table 10.1. Reset Electrical Characteristics .....	102
<b>11. Flash Memory</b>	
Table 11.1. Flash Electrical Characteristics .....	104
Table 11.2. Flash Security Summary .....	106
<b>12. External RAM</b>	
<b>13. Oscillators</b>	
Table 13.1. Internal Oscillator Electrical Characteristics .....	122
<b>14. Port Input/Output</b>	
Table 14.1. Port I/O DC Electrical Characteristics .....	134
<b>15. SMBus</b>	
Table 15.1. SMBus Clock Source Selection .....	140
Table 15.2. Minimum SDA Setup and Hold Times .....	141
Table 15.3. Sources for Hardware Changes to SMBOCN .....	145
Table 15.4. SMBus Status Decoding .....	151
<b>16. UART0</b>	
Table 16.1. Timer Settings for Standard Baud Rates Using the Internal 24.5 MHz Oscillator .....	160

# C8051F330/1/2/3/4/5

---

Table 16.2. Timer Settings for Standard Baud Rates Using an External 25.0 MHz Oscillator .....	160
Table 16.3. Timer Settings for Standard Baud Rates Using an External 22.1184 MHz Oscillator .....	161
Table 16.4. Timer Settings for Standard Baud Rates Using an External 18.432 MHz Oscillator .....	161
Table 16.5. Timer Settings for Standard Baud Rates Using an External 11.0592 MHz Oscillator .....	162
Table 16.6. Timer Settings for Standard Baud Rates Using an External 3.6864 MHz Oscillator .....	162
<b>17. Enhanced Serial Peripheral Interface (SPI0)</b>	
Table 17.1. SPI Slave Timing Parameters .....	175
<b>18. Timers</b>	
<b>19. Programmable Counter Array</b>	
Table 19.1. PCA Timebase Input Options .....	194
Table 19.2. PCA0CPM Register Settings for PCA Capture/Compare Modules ....	195
Table 19.3. Watchdog Timer Timeout Intervals1 .....	204
<b>20. C2 Interface</b>	

## List of Registers

SFR Definition 5.1. AMX0P: AMUX0 Positive Channel Select	47
SFR Definition 5.2. AMX0N: AMUX0 Negative Channel Select	48
SFR Definition 5.3. ADC0CF: ADC0 Configuration	49
SFR Definition 5.4. ADC0H: ADC0 Data Word MSB	49
SFR Definition 5.5. ADC0L: ADC0 Data Word LSB	49
SFR Definition 5.6. ADC0CN: ADC0 Control	50
SFR Definition 5.7. ADC0GTH: ADC0 Greater-Than Data High Byte	51
SFR Definition 5.8. ADC0GTL: ADC0 Greater-Than Data Low Byte	51
SFR Definition 5.9. ADC0LTH: ADC0 Less-Than Data High Byte	52
SFR Definition 5.10. ADC0LTL: ADC0 Less-Than Data Low Byte	52
SFR Definition 6.1. IDA0CN: IDA0 Control	59
SFR Definition 6.2. IDA0H: IDA0 Data Word MSB	59
SFR Definition 6.3. IDA0L: IDA0 Data Word LSB	60
SFR Definition 7.1. REF0CN: Reference Control	62
SFR Definition 8.1. CPT0CN: Comparator0 Control	67
SFR Definition 8.2. CPT0MX: Comparator0 MUX Selection	68
SFR Definition 8.3. CPT0MD: Comparator0 Mode Selection	69
SFR Definition 9.1. DPL: Data Pointer Low Byte	83
SFR Definition 9.2. DPH: Data Pointer High Byte	83
SFR Definition 9.3. SP: Stack Pointer	83
SFR Definition 9.4. PSW: Program Status Word	84
SFR Definition 9.5. ACC: Accumulator	85
SFR Definition 9.6. B: B Register	85
SFR Definition 9.7. IE: Interrupt Enable	89
SFR Definition 9.8. IP: Interrupt Priority	90
SFR Definition 9.9. EIE1: Extended Interrupt Enable 1	91
SFR Definition 9.10. EIP1: Extended Interrupt Priority 1	92
SFR Definition 9.11. IT01CF: INT0/INT1 Configuration	93
SFR Definition 9.12. PCON: Power Control	95
SFR Definition 10.1. VDM0CN: VDD Monitor Control	99
SFR Definition 10.2. RSTSRC: Reset Source	101
SFR Definition 11.1. PSCTL: Program Store R/W Control	108
SFR Definition 11.2. FLKEY: Flash Lock and Key	109
SFR Definition 11.3. FLSCL: Flash Scale	109
SFR Definition 12.1. EMI0CN: External Memory Interface Control	111
SFR Definition 13.1. OSCICL: Internal H-F Oscillator Calibration	114
SFR Definition 13.2. OSCICN: Internal H-F Oscillator Control	114
SFR Definition 13.3. OSCLCN: Internal L-F Oscillator Control	115
SFR Definition 13.4. OSCXCN: External Oscillator Control	117
SFR Definition 13.5. CLKSEL: Clock Select	121
SFR Definition 14.1. XBR0: Port I/O Crossbar Register 0	128
SFR Definition 14.2. XBR1: Port I/O Crossbar Register 1	129
SFR Definition 14.3. P0: Port0	130

# C8051F330/1/2/3/4/5

---

SFR Definition 14.4. P0MDIN: Port0 Input Mode	130
SFR Definition 14.5. P0MDOUT: Port0 Output Mode	131
SFR Definition 14.6. P0SKIP: Port0 Skip	131
SFR Definition 14.7. P1: Port1	131
SFR Definition 14.8. P1MDIN: Port1 Input Mode	132
SFR Definition 14.9. P1MDOUT: Port1 Output Mode	132
SFR Definition 14.10. P1SKIP: Port1 Skip	132
SFR Definition 14.11. P2: Port2	133
SFR Definition 14.12. P2MDOUT: Port2 Output Mode	133
SFR Definition 15.1. SMB0CF: SMBus Clock/Configuration	142
SFR Definition 15.2. SMB0CN: SMBus Control	144
SFR Definition 15.3. SMB0DAT: SMBus Data	146
SFR Definition 16.1. SCON0: Serial Port 0 Control	158
SFR Definition 16.2. SBUF0: Serial (UART0) Port Data Buffer	159
SFR Definition 17.1. SPI0CFG: SPI0 Configuration	170
SFR Definition 17.2. SPI0CN: SPI0 Control	171
SFR Definition 17.3. SPI0CKR: SPI0 Clock Rate	172
SFR Definition 17.4. SPI0DAT: SPI0 Data	172
SFR Definition 18.1. TCON: Timer Control	181
SFR Definition 18.2. TMOD: Timer Mode	182
SFR Definition 18.3. CKCON: Clock Control	183
SFR Definition 18.4. TL0: Timer 0 Low Byte	184
SFR Definition 18.5. TL1: Timer 1 Low Byte	184
SFR Definition 18.6. TH0: Timer 0 High Byte	184
SFR Definition 18.7. TH1: Timer 1 High Byte	184
SFR Definition 18.8. TMR2CN: Timer 2 Control	187
SFR Definition 18.9. TMR2RLL: Timer 2 Reload Register Low Byte	188
SFR Definition 18.10. TMR2RLH: Timer 2 Reload Register High Byte	188
SFR Definition 18.11. TMR2L: Timer 2 Low Byte	188
SFR Definition 18.12. TMR2H: Timer 2 High Byte	188
SFR Definition 18.13. TMR3CN: Timer 3 Control	191
SFR Definition 18.14. TMR3RLL: Timer 3 Reload Register Low Byte	192
SFR Definition 18.15. TMR3RLH: Timer 3 Reload Register High Byte	192
SFR Definition 18.16. TMR3L: Timer 3 Low Byte	192
SFR Definition 18.17. TMR3H: Timer 3 High Byte	192
SFR Definition 19.1. PCA0CN: PCA Control	205
SFR Definition 19.2. PCA0MD: PCA Mode	206
SFR Definition 19.3. PCA0CPMn: PCA Capture/Compare Mode	207
SFR Definition 19.4. PCA0L: PCA Counter/Timer Low Byte	208
SFR Definition 19.5. PCA0H: PCA Counter/Timer High Byte	208
SFR Definition 19.6. PCA0CPLn: PCA Capture Module Low Byte	208
SFR Definition 19.7. PCA0CPHn: PCA Capture Module High Byte	208
C2 Register Definition 20.1. C2ADD: C2 Address	209
C2 Register Definition 20.2. DEVICEID: C2 Device ID	209
C2 Register Definition 20.3. REVID: C2 Revision ID	210

---

# C8051F330/1/2/3/4/5

---

C2 Register Definition 20.4. FPCTL: C2 Flash Programming Control	210
C2 Register Definition 20.5. FPDAT: C2 Flash Programming Data	210

# C8051F330/1/2/3/4/5

---



## 1. System Overview

C8051F330/1/2/3/4/5 devices are fully integrated mixed-signal System-on-a-Chip MCUs. Highlighted features are listed below. Refer to Table 1.1 for specific product feature selection.

- High-speed pipelined 8051-compatible microcontroller core (up to 25 MIPS)
- In-system, full-speed, non-intrusive debug interface (on-chip)
- True 10-bit 200 ksps 16-channel single-ended/differential ADC with analog multiplexer
- 10-bit Current Output DAC
- Precision programmable 25 MHz internal oscillator
- Up to 8 kB of on-chip Flash memory—512 bytes are reserved
- 768 bytes of on-chip RAM
- SMBus/I2C, Enhanced UART, and Enhanced SPI serial interfaces implemented in hardware
- Four general-purpose 16-bit timers
- Programmable Counter/Timer Array (PCA) with three capture/compare modules and Watchdog Timer function
- On-chip Power-On Reset,  $V_{DD}$  Monitor, and Temperature Sensor
- On-chip Voltage Comparator
- 17 Port I/O (5 V tolerant)

With on-chip Power-On Reset,  $V_{DD}$  monitor, Watchdog Timer, and clock oscillator, the C8051F330/1/2/3/4/5 devices are truly stand-alone System-on-a-Chip solutions. The Flash memory can be reprogrammed even in-circuit, providing non-volatile data storage, and also allowing field upgrades of the 8051 firmware. User software has complete control of all peripherals, and may individually shut down any or all peripherals for power savings.

The on-chip Silicon Labs 2-Wire (C2) Development Interface allows non-intrusive (uses no on-chip resources), full speed, in-circuit debugging using the production MCU installed in the final application. This debug logic supports inspection and modification of memory and registers, setting breakpoints, single stepping, run and halt commands. All analog and digital peripherals are fully functional while debugging using C2. The two C2 interface pins can be shared with user functions, allowing in-system debugging without occupying package pins.

Each device is specified for 2.7 to 3.6 V operation over the industrial temperature range (–40 to +85 °C). The Port I/O and RST pins are tolerant of input signals up to 5 V. The C8051F330/1/2/3/4/5 are available in 20-pin QFN packages (also referred to as MLP or MLF packages). Lead-free (RoHS compliant) packages are also available. See Table 1.1 for ordering part numbers. Block diagrams are included in Figure 1.1, Figure 1.2, Figure 1.3, Figure 1.4, Figure 1.5, and Figure 1.6.

# C8051F330/1/2/3/4/5

**Table 1.1. Product Selection Guide**

Ordering Part Number	MIPS (Peak)	Flash Memory (kB)	RAM (bytes)	Calibrated Internal 24.5 MHz Oscillator	Internal 80 kHz Oscillator	SMBus/I <sup>2</sup> C	Enhanced SPI	UART	Timers (16-bit)	Programmable Counter Array	Digital Port I/Os	10-bit 200kps ADC	10-bit Current Output DAC	Internal Voltage Reference	Temperature Sensor	Analog Comparator	Lead-free (RoHS Compliant)	Package
C8051F330-GM	25	8	768	✓	✓	✓	✓	✓	4	✓	17	✓	✓	✓	✓	✓	✓	QFN-20
C8051F331-GM	25	8	768	✓	✓	✓	✓	✓	4	✓	17	—	—	—	—	✓	✓	QFN-20
C8051F332-GM	25	4	768	✓	✓	✓	✓	✓	4	✓	17	✓	—	✓	✓	✓	✓	QFN-20
C8051F333-GM	25	4	768	✓	✓	✓	✓	✓	4	✓	17	—	—	—	—	✓	✓	QFN-20
C8051F334-GM	25	2	768	✓	✓	✓	✓	✓	4	✓	17	✓	—	✓	✓	✓	✓	QFN-20
C8051F335-GM	25	2	768	✓	✓	✓	✓	✓	4	✓	17	—	—	—	—	✓	✓	QFN-20

# C8051F330/1/2/3/4/5

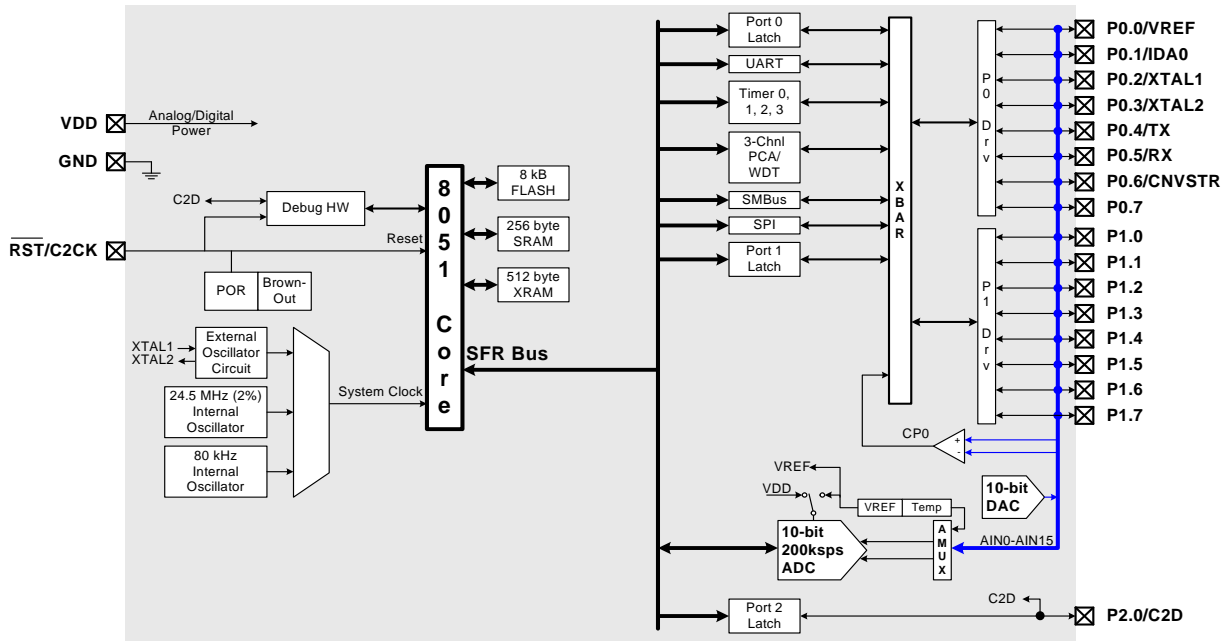

Figure 1.1. C8051F330 Block Diagram

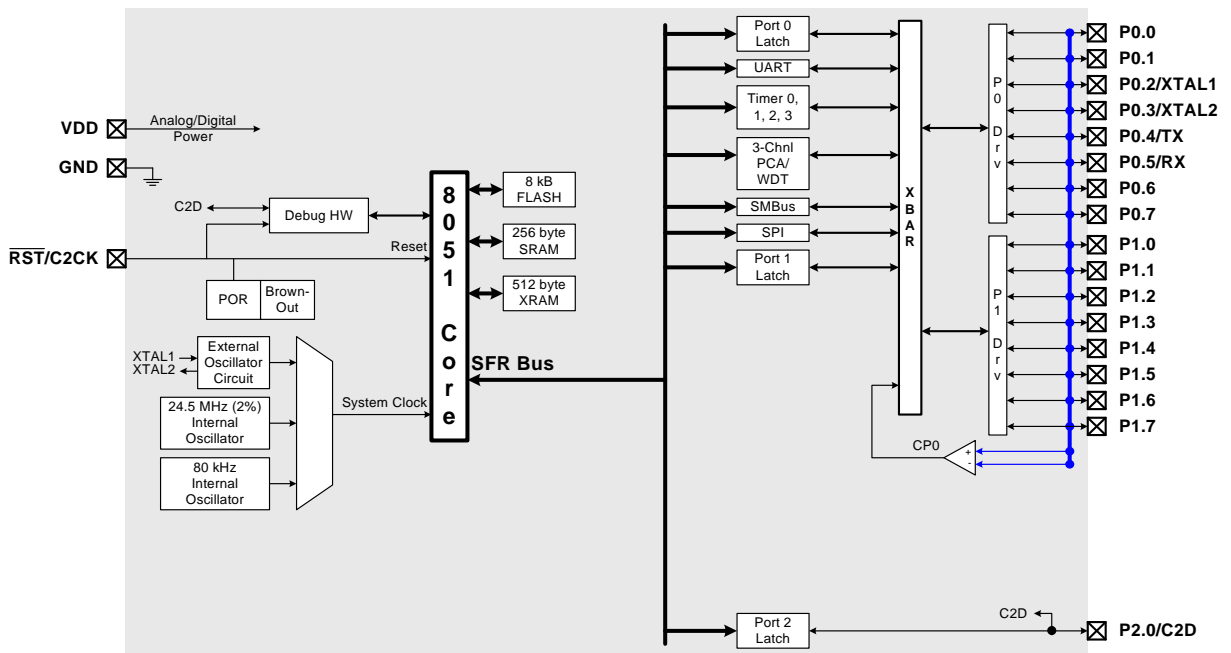

Figure 1.2. C8051F331 Block Diagram

# C8051F330/1/2/3/4/5

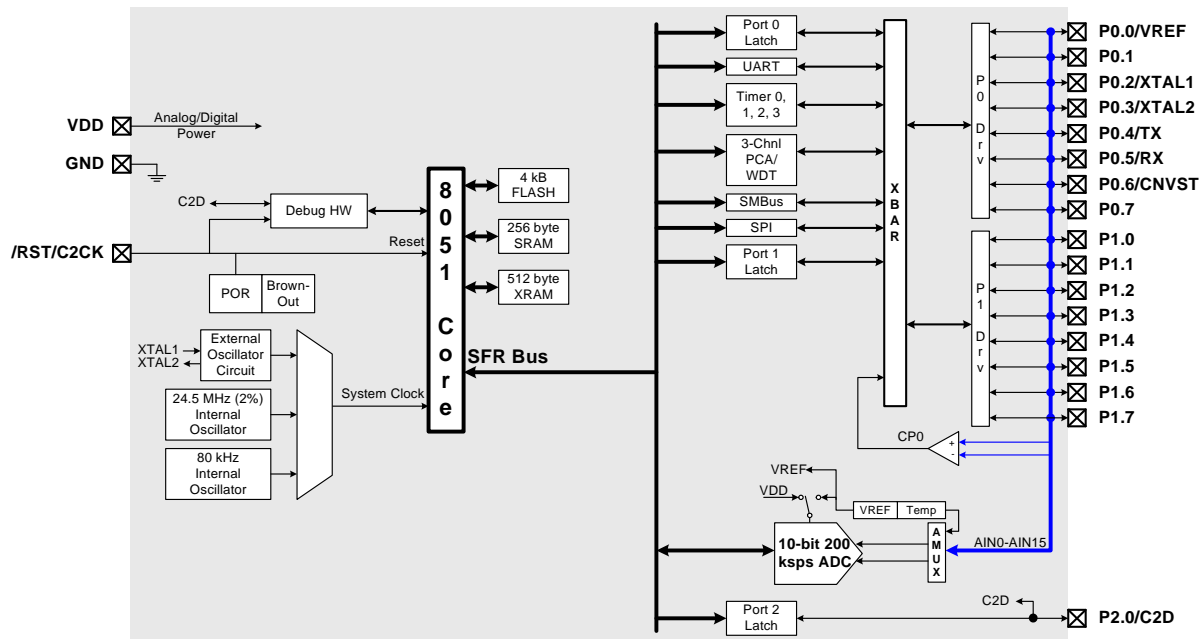

Figure 1.3. C8051F332 Block Diagram

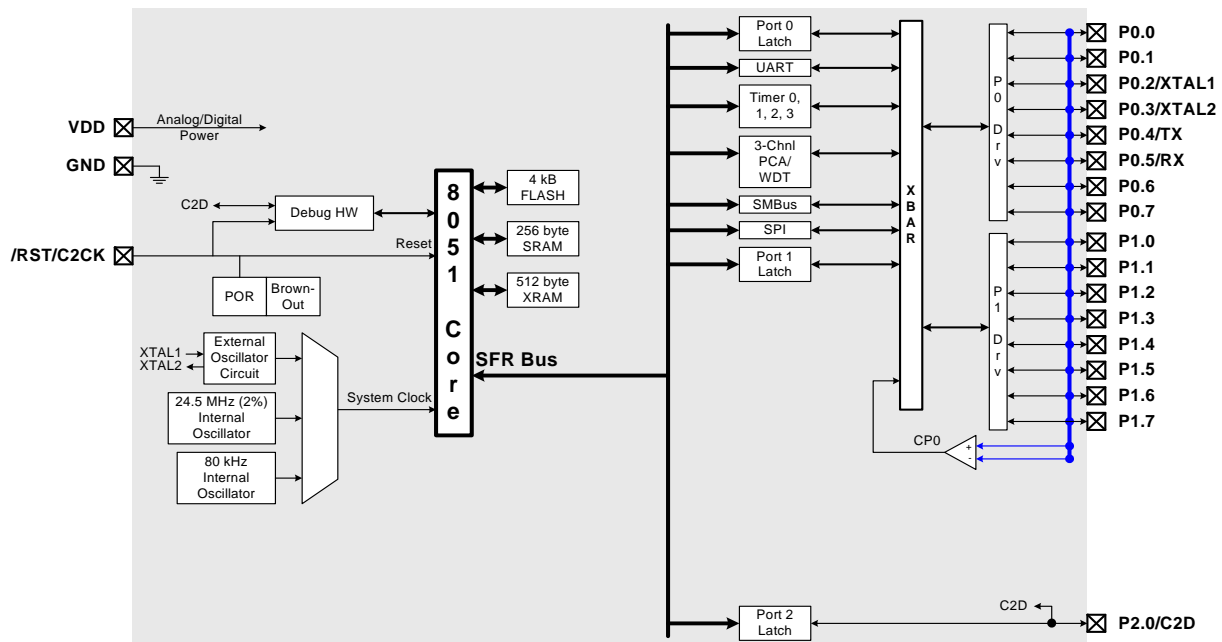

Figure 1.4. C8051F333 Block Diagram

# C8051F330/1/2/3/4/5

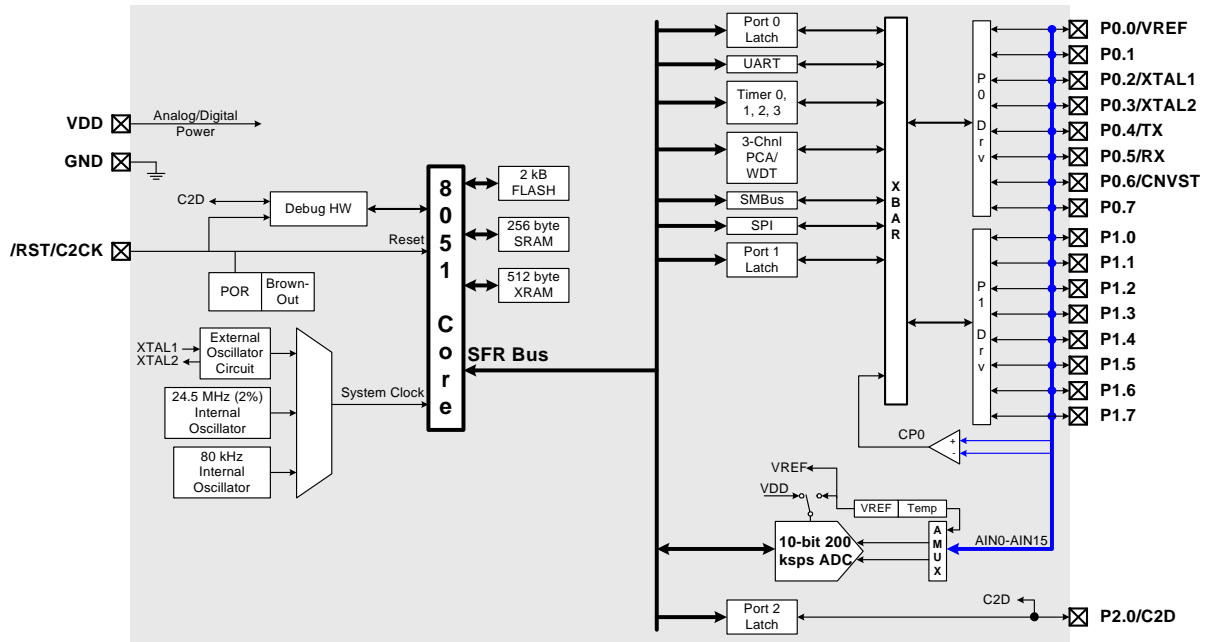

Figure 1.5. C8051F334 Block Diagram

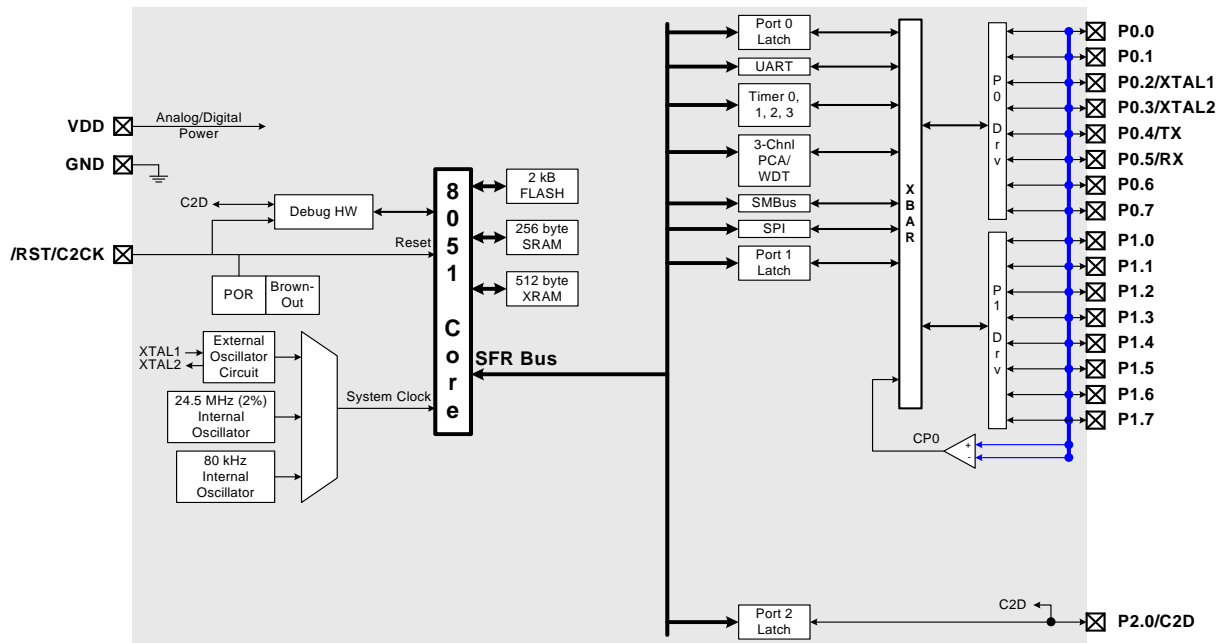

Figure 1.6. C8051F335 Block Diagram

# C8051F330/1/2/3/4/5

## 1.1. CIP-51™ Microcontroller Core

### 1.1.1. Fully 8051 Compatible

The C8051F330/1/2/3/4/5 family utilizes Silicon Labs' proprietary CIP-51 microcontroller core. The CIP-51 is fully compatible with the MCS-51™ instruction set; standard 803x/805x assemblers and compilers can be used to develop software. The CIP-51 core offers all the peripherals included with a standard 8052, including four 16-bit counter/timers, a full-duplex UART with extended baud rate configuration, an enhanced SPI port, 768 bytes of internal RAM, 128 byte Special Function Register (SFR) address space, and 17 I/O pins.

### 1.1.2. Improved Throughput

The CIP-51 employs a pipelined architecture that greatly increases its instruction throughput over the standard 8051 architecture. In a standard 8051, all instructions except for MUL and DIV take 12 or 24 system clock cycles to execute with a maximum system clock of 12-to-24 MHz. By contrast, the CIP-51 core executes 70% of its instructions in one or two system clock cycles, with only four instructions taking more than four system clock cycles.

The CIP-51 has a total of 109 instructions. The table below shows the total number of instructions that require each execution time.

Clocks to Execute	1	2	2/3	3	3/4	4	4/5	5	8
Number of Instructions	26	50	5	14	7	3	1	2	1

With the CIP-51's maximum system clock at 25 MHz, it has a peak throughput of 25 MIPS. Figure 1.7 shows a comparison of peak throughputs for various 8-bit microcontroller cores with their maximum system clocks.

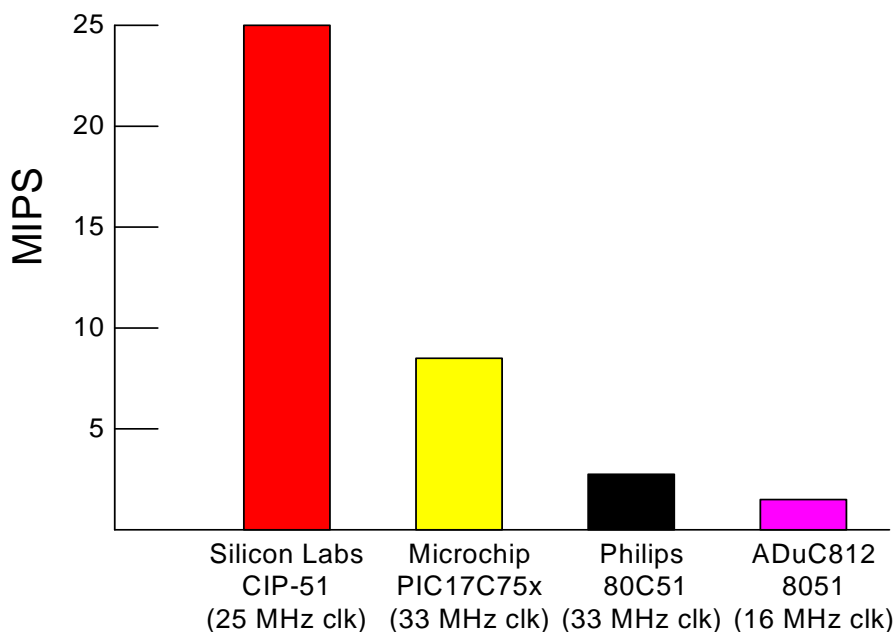

Figure 1.7. Comparison of Peak MCU Execution Speeds

## 1.1.3. Additional Features

The C8051F330/1/2/3/4/5 SoC family includes several key enhancements to the CIP-51 core and peripherals to improve performance and ease of use in end applications.

The extended interrupt handler provides 14 interrupt sources into the CIP-51 (as opposed to 7 for the standard 8051), allowing numerous analog and digital peripherals to interrupt the controller. An interrupt driven system requires less intervention by the MCU, giving it more effective throughput. The extra interrupt sources are very useful when building multi-tasking, real-time systems.

Eight reset sources are available: power-on reset circuitry (POR), an on-chip  $V_{DD}$  monitor (forces reset when power supply voltage drops below  $V_{RST}$  as given in Table 10.1 on page 102), a Watchdog Timer, a Missing Clock Detector, a voltage level detection from Comparator0, a forced software reset, an external reset pin, and an illegal Flash access protection circuit. Each reset source except for the POR, Reset Input Pin, or Flash error may be disabled by the user in software. The WDT may be permanently enabled in software after a power-on reset during MCU initialization.

The internal oscillator factory calibrated to 24.5 MHz  $\pm 2\%$ . This internal oscillator period may be user programmed in  $\sim 0.5\%$  increments. An additional low-frequency oscillator is also available which facilitates low-power operation. An external oscillator drive circuit is included, allowing an external crystal, ceramic resonator, capacitor, RC, or CMOS clock source to generate the system clock. If desired, the system clock source may be switched on-the-fly between both internal and external oscillator circuits. An external oscillator can also be extremely useful in low power applications, allowing the MCU to run from a slow (power saving) source, while periodically switching to the fast (up to 25 MHz) internal oscillator as needed.

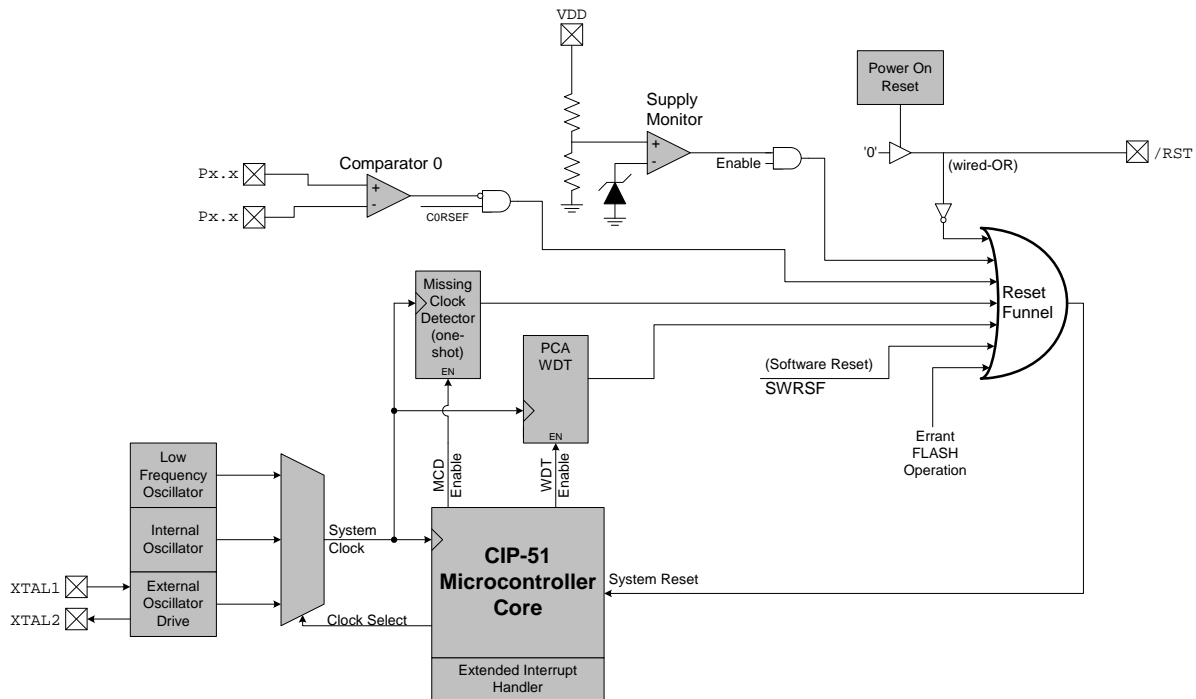

**Figure 1.8. On-Chip Clock and Reset**

# C8051F330/1/2/3/4/5

## 1.2. On-Chip Memory

The CIP-51 has a standard 8051 program and data address configuration. It includes 256 bytes of data RAM, with the upper 128 bytes dual-mapped. Indirect addressing accesses the upper 128 bytes of general purpose RAM, and direct addressing accesses the 128 byte SFR address space. The lower 128 bytes of RAM are accessible via direct and indirect addressing. The first 32 bytes are addressable as four banks of general purpose registers, and the next 16 bytes can be byte addressable or bit addressable.

Program memory consists of 2/4/8 kB of Flash. This memory may be reprogrammed in-system in 512 byte sectors, and requires no special off-chip programming voltage. See Figure 1.9 for the MCU system memory map.

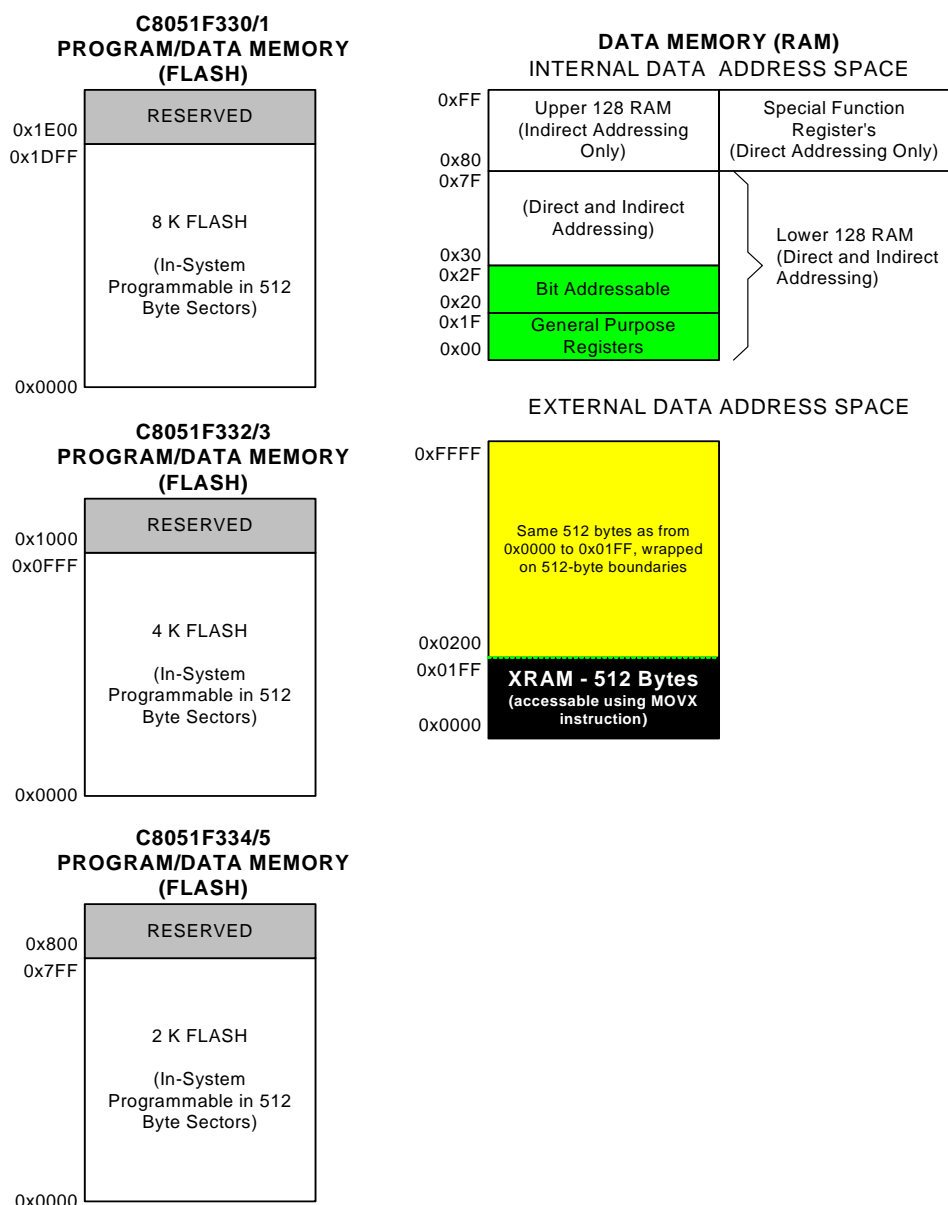

Figure 1.9. On-Board Memory Map



## 1.3. On-Chip Debug Circuitry

The C8051F330/1/2/3/4/5 devices include on-chip Silicon Labs 2-Wire (C2) debug circuitry that provides non-intrusive, full speed, in-circuit debugging of the production part *installed in the end application*.

Silicon Labs' debugging system supports inspection and modification of memory and registers, breakpoints, and single stepping. No additional target RAM, program memory, timers, or communications channels are required. All the digital and analog peripherals are functional and work correctly while debugging. All the peripherals (except for the ADC and SMBus) are stalled when the MCU is halted, during single stepping, or at a breakpoint in order to keep them synchronized.

The C8051F330DK development kit provides all the hardware and software necessary to develop application code and perform in-circuit debugging with the C8051F330/1/2/3/4/5 MCUs. The kit includes software with a developer's studio and debugger, an integrated 8051 assembler, and a debug adapter. It also has a target application board with the associated MCU installed and prototyping area, plus the required cables, and wall-mount power supply. The Development Kit requires a PC running Windows98SE or later.

The Silicon Labs IDE interface is a vastly superior developing and debugging configuration, compared to standard MCU emulators that use on-board "ICE Chips" and require the MCU in the application board to be socketed. Silicon Labs' debug paradigm increases ease of use and preserves the performance of the precision analog peripherals.

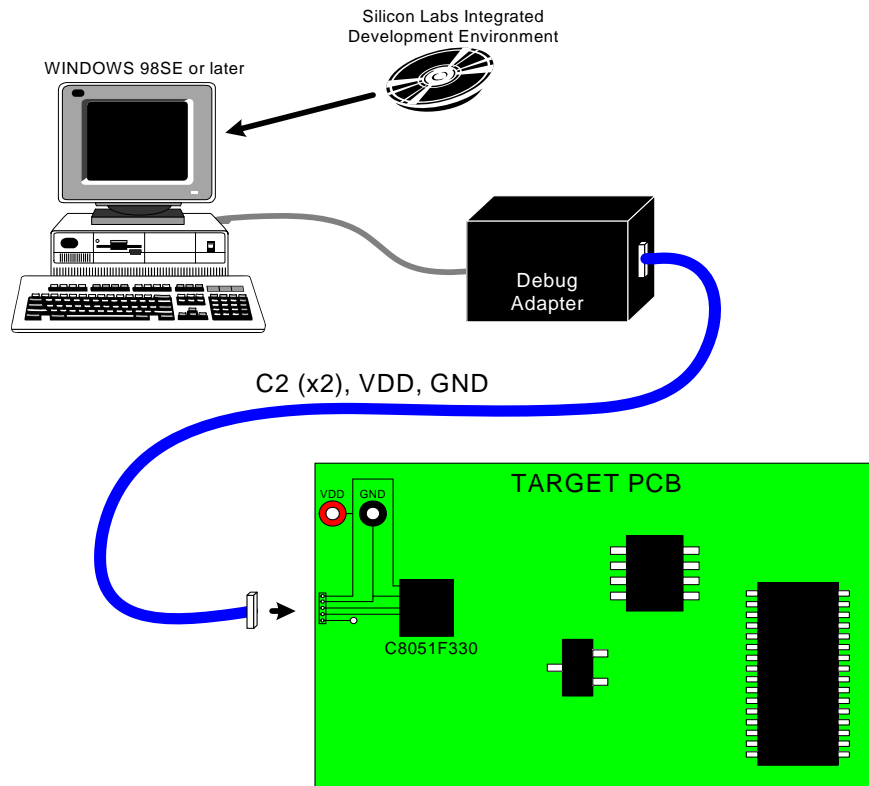

Figure 1.10. Development/In-System Debug Diagram

# C8051F330/1/2/3/4/5

## 1.4. Programmable Digital I/O and Crossbar

C8051F330/1/2/3/4/5 devices include 17 I/O pins (two byte-wide Ports and one 1-bit-wide Port). The C8051F330/1/2/3/4/5 Ports behave like typical 8051 Ports with a few enhancements. Each Port pin may be configured as an analog input or a digital I/O pin. Pins selected as digital I/Os may additionally be configured for push-pull or open-drain output. The “weak pullups” that are fixed on typical 8051 devices may be globally disabled, providing power savings capabilities.

The Digital Crossbar allows mapping of internal digital system resources to Port I/O pins. (See Figure 1.11.) On-chip counter/timers, serial buses, HW interrupts, comparator output, and other digital signals in the controller can be configured to appear on the Port I/O pins specified in the Crossbar Control registers. This allows the user to select the exact mix of general purpose Port I/O and digital resources needed for the particular application.

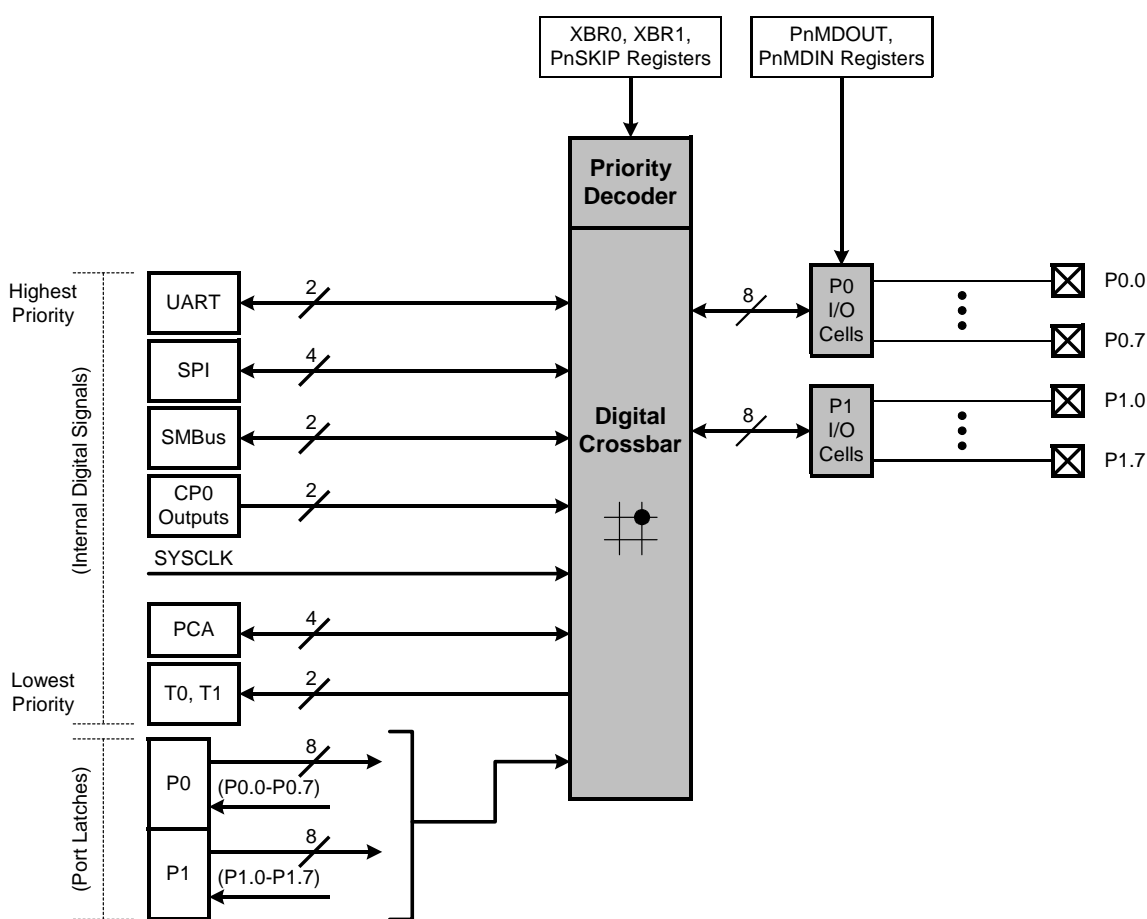

Figure 1.11. Digital Crossbar Diagram

## 1.5. Serial Ports

The C8051F330/1/2/3/4/5 Family includes an SMBus/I<sup>2</sup>C interface, a full-duplex UART with enhanced baud rate configuration, and an Enhanced SPI interface. Each of the serial buses is fully implemented in hardware and makes extensive use of the CIP-51's interrupts, thus requiring very little CPU intervention.

### 1.6. Programmable Counter Array

An on-chip Programmable Counter/Timer Array (PCA) is included in addition to the four 16-bit general purpose counter/timers. The PCA consists of a dedicated 16-bit counter/timer time base with three programmable capture/compare modules. The PCA clock is derived from one of six sources: the system clock divided by 12, the system clock divided by 4, Timer 0 overflows, an External Clock Input (ECI), the system clock, or the external oscillator clock source divided by 8. The external clock source selection is useful for real-time clock functionality, where the PCA is clocked by an external source while the internal oscillator drives the system clock.

Each capture/compare module can be configured to operate in one of six modes: Edge-Triggered Capture, Software Timer, High Speed Output, 8- or 16-bit Pulse Width Modulator, or Frequency Output. Additionally, Capture/Compare Module 2 offers watchdog timer (WDT) capabilities. Following a system reset, Module 2 is configured and enabled in WDT mode. The PCA Capture/Compare Module I/O and External Clock Input may be routed to Port I/O via the Digital Crossbar.

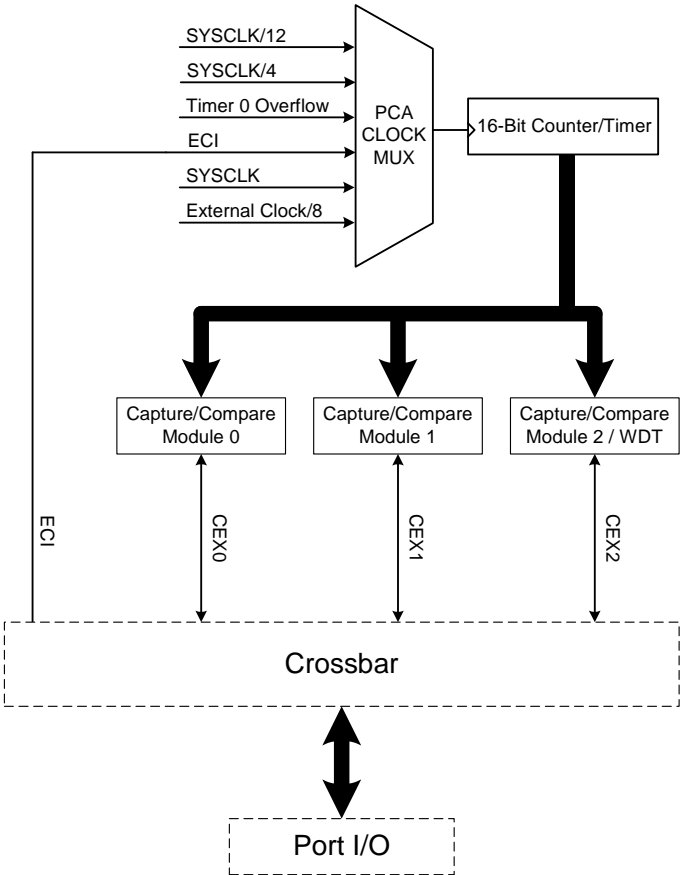

Figure 1.13. PCA Block Diagram

# C8051F330/1/2/3/4/5

## 1.7. 10-Bit Analog to Digital Converter

The C8051F330/2/4 devices include an on-chip 10-bit SAR ADC with a 16-channel differential input multiplexer. With a maximum throughput of 200 ksps, the ADC offers true 10-bit linearity with an INL and DNL of  $\pm 1$  LSB. The ADC system includes a configurable analog multiplexer that selects both positive and negative ADC inputs. Ports0-1 are available as an ADC inputs; additionally, the on-chip Temperature Sensor output and the power supply voltage ( $V_{DD}$ ) are available as ADC inputs. User firmware may shut down the ADC to save power.

Conversions can be started in six ways: a software command, an overflow of Timer 0, 1, 2, or 3, or an external convert start signal. This flexibility allows the start of conversion to be triggered by software events, a periodic signal (timer overflows), or external HW signals. Conversion completions are indicated by a status bit and an interrupt (if enabled). The resulting 10-bit data word is latched into the ADC data SFRs upon completion of a conversion.

Window compare registers for the ADC data can be configured to interrupt the controller when ADC data is either within or outside of a specified range. The ADC can monitor a key voltage continuously in background mode, but not interrupt the controller unless the converted data is within/outside the specified range.

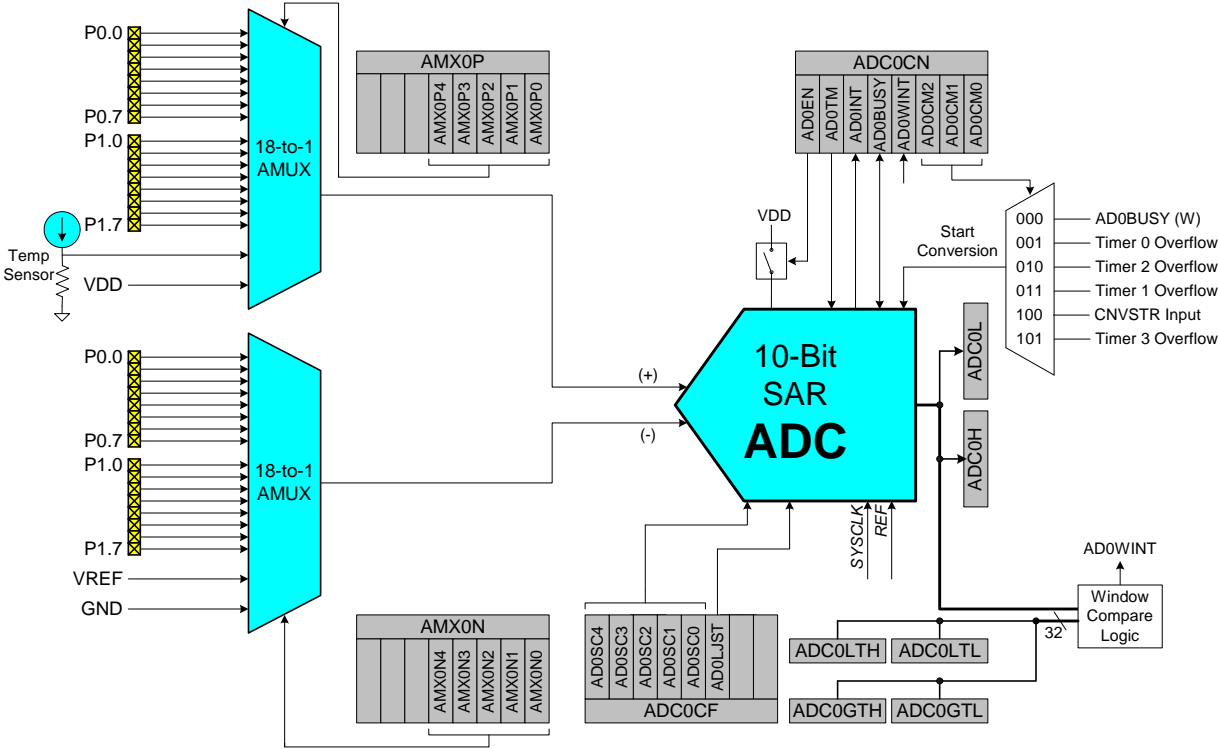

Figure 1.14. 10-Bit ADC Block Diagram

## 1.8. Comparators

C8051F330/1/2/3/4/5 devices include an on-chip voltage comparator that is enabled/disabled and configured via user software. Port I/O pins may be configured as comparator inputs via a selection mux. Two comparator outputs may be routed to a Port pin if desired: a latched output and/or an unlatched (asynchronous) output. Comparator response time is programmable, allowing the user to select between high-speed and low-power modes. Positive and negative hysteresis are also configurable.

Comparator interrupts may be generated on rising, falling, or both edges. When in IDLE mode, these interrupts may be used as a “wake-up” source. Comparator0 may also be configured as a reset source. Figure 1.15 shows the Comparator0 block diagram.

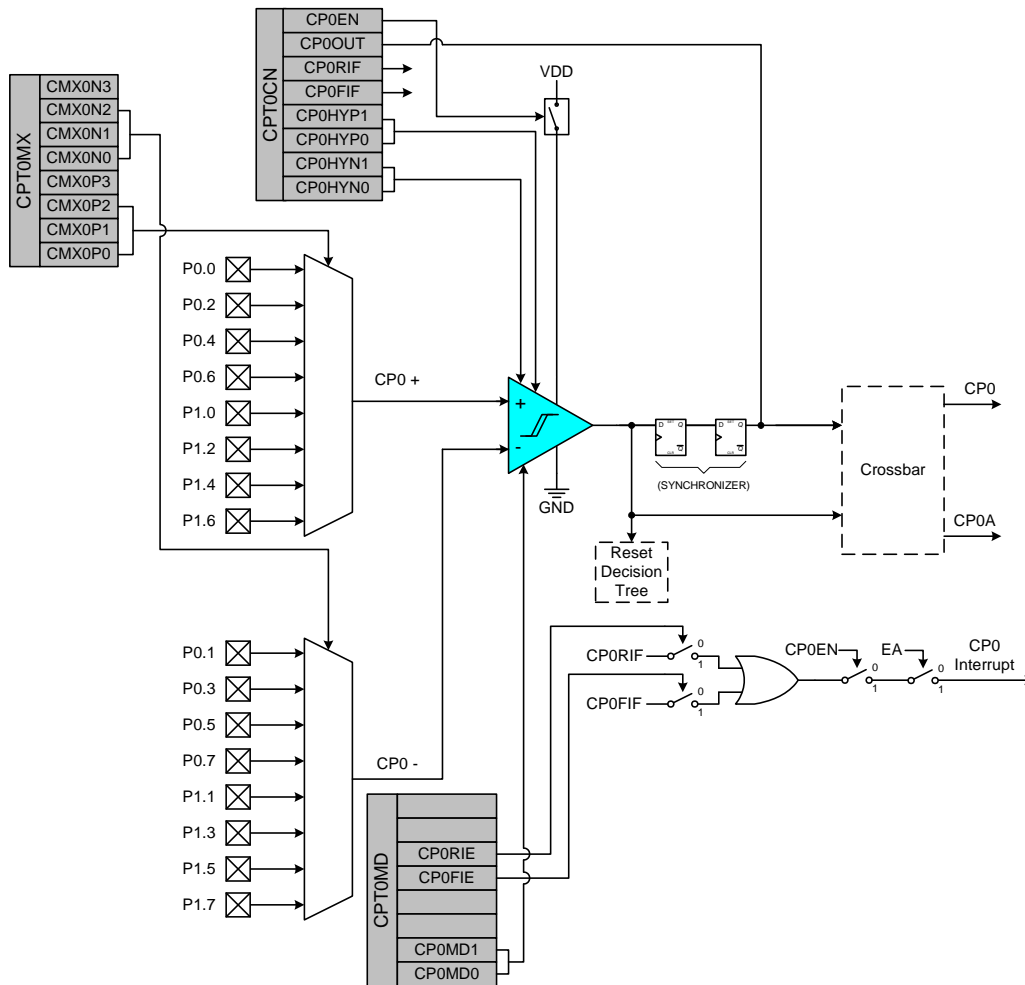

Figure 1.15. Comparator0 Block Diagram

# C8051F330/1/2/3/4/5

## 1.9. 10-bit Current Output DAC

The C8051F330 device includes a 10-bit current-mode Digital-to-Analog Converter (IDA0). The maximum current output of the IDA0 can be adjusted for three different current settings; 0.5 mA, 1 mA, and 2 mA. IDA0 features a flexible output update mechanism which allows for seamless full-scale changes and supports jitter-free updates for waveform generation. Three update modes are provided, allowing IDA0 output updates on a write to IDA0H, on a Timer overflow, or on an external pin edge.

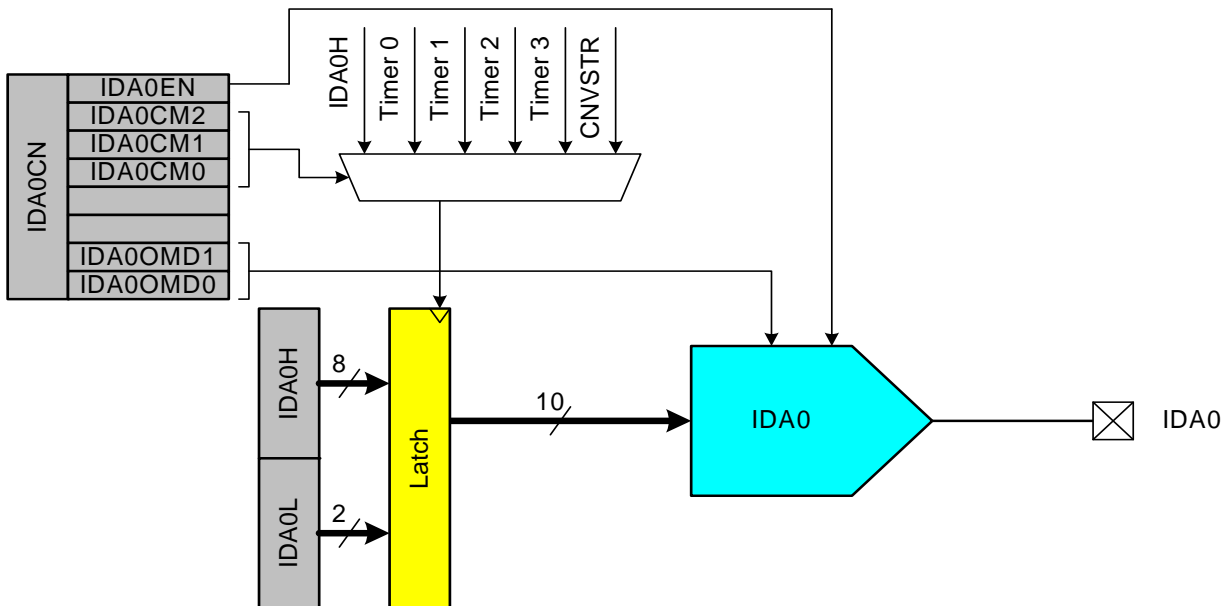

Figure 1.16. IDA0 Functional Block Diagram

## 2. Absolute Maximum Ratings

Table 2.1. Absolute Maximum Ratings

Parameter	Conditions	Min	Typ	Max	Units
Ambient temperature under bias		-55	—	125	°C
Storage Temperature		-65	—	150	°C
Voltage on any Port I/O Pin or $\overline{\text{RST}}$ with respect to GND		-0.3	—	5.8	V
Voltage on $V_{\text{DD}}$ with respect to GND		-0.3	—	4.2	V
Maximum Total current through $V_{\text{DD}}$ or GND		—	—	500	mA
Maximum output current sunk by $\overline{\text{RST}}$ or any Port pin		—	—	100	mA
<p><b>Note:</b> Stresses above those listed under “Absolute Maximum Ratings” may cause permanent damage to the device. This is a stress rating only and functional operation of the devices at those or any other conditions above those indicated in the operation listings of this specification is not implied. Exposure to maximum rating conditions for extended periods may affect device reliability.</p>					

# C8051F330/1/2/3/4/5

## 3. Global Electrical Characteristics

**Table 3.1. Global Electrical Characteristics**

–40 to +85 °C, 25 MHz system clock unless otherwise specified.

Parameter	Conditions	Min	Typ	Max	Units
Digital Supply Voltage		$V_{RST}^1$	3.0	3.6	V
Digital Supply RAM Data Retention Voltage		—	1.5	—	V
SYSCLK (System Clock) (Note 2)		0	—	25	MHz
$T_{SYSH}$ (SYSCLK High Time)		18	—	—	ns
$T_{SYSL}$ (SYSCLK Low Time)		18	—	—	ns
Specified Operating Temperature Range		–40	—	+85	°C
<b>Digital Supply Current—CPU Active (Normal Mode, fetching instructions from Flash)</b>					
$I_{DD}$ (Note 3)	$V_{DD} = 3.6$ V, $F = 25$ MHz	—	10.7	11.7	mA
	$V_{DD} = 3.0$ V, $F = 25$ MHz	—	7.8	8.3	mA
	$V_{DD} = 3.0$ V, $F = 1$ MHz	—	0.38	—	mA
	$V_{DD} = 3.0$ V, $F = 80$ kHz	—	31	—	μA
$I_{DD}$ Supply Sensitivity (Note 3)	$F = 25$ MHz	—	65	—	%/V
	$F = 1$ MHz	—	61	—	%/V
$I_{DD}$ Frequency Sensitivity (Note 3, Note 4)	$V_{DD} = 3.0$ V, $F \leq 15$ MHz, $T = 25$ °C	—	0.38	—	mA/MHz
	$V_{DD} = 3.0$ V, $F > 15$ MHz, $T = 25$ °C	—	0.21	—	mA/MHz
	$V_{DD} = 3.6$ V, $F \leq 15$ MHz, $T = 25$ °C	—	0.53	—	mA/MHz
	$V_{DD} = 3.6$ V, $F > 15$ MHz, $T = 25$ °C	—	0.27	—	mA/MHz



**Table 3.1. Global Electrical Characteristics**

–40 to +85 °C, 25 MHz system clock unless otherwise specified.

Parameter	Conditions	Min	Typ	Max	Units
<b>Digital Supply Current—CPU Inactive (Idle Mode, not fetching instructions from Flash)</b>					
I <sub>DD</sub> (Note 3)	V <sub>DD</sub> = 3.6 V, F = 25 MHz	—	4.8	5.2	mA
	V <sub>DD</sub> = 3.0 V, F = 25 MHz	—	3.8	4.1	mA
	V <sub>DD</sub> = 3.0 V, F = 1 MHz	—	0.20	—	mA
	V <sub>DD</sub> = 3.0 V, F = 80 kHz	—	16	—	µA
I <sub>DD</sub> Supply Sensitivity (Note 3)	F = 25 MHz	—	43	—	%/V
	F = 1 MHz	—	55	—	%/V
I <sub>DD</sub> Frequency Sensitivity (Note 3, Note 5)	V <sub>DD</sub> = 3.0 V, F ≤ 1 MHz, T = 25 °C	—	0.20	—	mA/MHz
	V <sub>DD</sub> = 3.0 V, F > 1 MHz, T = 25 °C	—	0.15	—	mA/MHz
	V <sub>DD</sub> = 3.6 V, F ≤ 1 MHz, T = 25 °C	—	0.24	—	mA/MHz
	V <sub>DD</sub> = 3.6 V, F > 1 MHz, T = 25 °C	—	0.19	—	mA/MHz
Digital Supply Current (Stop Mode, shutdown)	Oscillator not running, V <sub>DD</sub> Monitor Disabled	—	< 0.1	—	µA
<b>Notes:</b> <ol style="list-style-type: none"> <li>Given in Table 10.1 on page 102.</li> <li>SYSCCLK must be at least 32 kHz to enable debugging.</li> <li>Based on device characterization data; Not production tested.</li> <li>IDD can be estimated for frequencies ≤ 15 MHz by simply multiplying the frequency of interest by the frequency sensitivity number for that range. When using these numbers to estimate I<sub>DD</sub> for &gt;15 MHz, the estimate should be the current at 25 MHz minus the difference in current indicated by the frequency sensitivity number. For example: V<sub>DD</sub> = 3.0 V; F = 20 MHz, I<sub>DD</sub> = 7.8 mA - (25 MHz - 20 MHz) * 0.21 mA/MHz = 6.75 mA.</li> <li>Idle IDD can be estimated for frequencies ≤ 1 MHz by simply multiplying the frequency of interest by the frequency sensitivity number for that range. When using these numbers to estimate Idle I<sub>DD</sub> for &gt;1 MHz, the estimate should be the current at 25 MHz minus the difference in current indicated by the frequency sensitivity number. For example: V<sub>DD</sub> = 3.0 V; F = 5 MHz, Idle I<sub>DD</sub> = 4.8 mA - (25 MHz - 5 MHz) * 0.15 mA/MHz = 1.8 mA.</li> </ol>					

Other electrical characteristics tables are found in the data sheet section corresponding to the associated peripherals. For more information on electrical characteristics for a specific peripheral, refer to the page indicated in Table 3.2.

# C8051F330/1/2/3/4/5

**Table 3.2. Index to Electrical Characteristics Tables**

<b>Peripheral Electrical Characteristics</b>	<b>Page No.</b>
ADC0 Electrical Characteristics	55
IDAC Electrical Characteristics	60
Voltage Reference Electrical Characteristics	63
Comparator Electrical Characteristics	70
Reset Electrical Characteristics	102
Flash Electrical Characteristics	104
Internal Oscillator Electrical Characteristics	122
Port I/O DC Electrical Characteristics	134

## 4. Pinout and Package Definitions

Table 4.1. Pin Definitions for the C8051F330/1/2/3/4/5

Name	Pin 'F330/1/2/ 3/4/5-GM	Pin 'F330-GP	Type	Description
V <sub>DD</sub>	3	6		Power Supply Voltage.
GND	2	5		Ground.
$\overline{\text{RST}}$	4	7	D I/O	Device Reset. Open-drain output of internal POR or V <sub>DD</sub> monitor. An external source can initiate a system reset by driving this pin low for at least 10 $\mu\text{s}$ .
C2CK			D I/O	Clock signal for the C2 Debug Interface.
P2.0/ C2D	5	8	D I/O D I/O	Port 3.0. See <a href="#">Section 14</a> for a complete description. Bi-directional data signal for the C2 Debug Interface.
P0.0/ VREF	1	4	D I/O or A In A In	Port 0.0. See <a href="#">Section 14</a> for a complete description. External VREF input. See <a href="#">Section 7</a> for a complete description.
P0.1 IDA0	20	3	D I/O or A In AOut	Port 0.1. See <a href="#">Section 14</a> for a complete description. IDA0 Output. See <a href="#">Section 6</a> for a complete description.
P0.2/ XTAL1	19	2	D I/O or A In A In	Port 0.2. See <a href="#">Section 14</a> for a complete description. External Clock Input. This pin is the external oscillator return for a crystal or resonator. See <a href="#">Section 13</a> for a complete description.
P0.3/ XTAL2	18	1	D I/O or A In A I/O or D In	Port 0.3. See <a href="#">Section 14</a> for a complete description. External Clock Output. For an external crystal or resonator, this pin is the excitation driver. This pin is the external clock input for CMOS, capacitor, or RC oscillator configurations. See <a href="#">Section 13</a> for a complete description.
P0.4	17	20	D I/O or A In	Port 0.4. See <a href="#">Section 14</a> for a complete description.
P0.5	16	19	D I/O or A In	Port 0.5. See <a href="#">Section 14</a> for a complete description.

# C8051F330/1/2/3/4/5

**Table 4.1. Pin Definitions for the C8051F330/1/2/3/4/5 (Continued)**

Name	Pin 'F330/1/2/ 3/4/5-GM	Pin 'F330-GP	Type	Description
P0.6/  CNVSTR	15	18	D I/O or A In  D In	Port 0.6. See <a href="#">Section 14</a> for a complete description.  ADC0 External Convert Start or IDA0 Update Source Input. See <a href="#">Section 5</a> and <a href="#">Section 6</a> for a complete description.
P0.7	14	17	D I/O or A In	Port 0.7. See <a href="#">Section 14</a> for a complete description.
P1.0	13	16	D I/O or A In	Port 1.0. See <a href="#">Section 14</a> for a complete description.
P1.1	12	15	D I/O or A In	Port 1.1. See <a href="#">Section 14</a> for a complete description.
P1.2	11	14	D I/O or A In	Port 1.2. See <a href="#">Section 14</a> for a complete description.
P1.3	10	13	D I/O or A In	Port 1.3. See <a href="#">Section 14</a> for a complete description.
P1.4	9	12	D I/O or A In	Port 1.4. See <a href="#">Section 14</a> for a complete description.
P1.5	8	11	D I/O or A In	Port 1.5. See <a href="#">Section 14</a> for a complete description.
P1.6	7	10	D I/O or A In	Port 1.6. See <a href="#">Section 14</a> for a complete description.
P1.7	6	9	D I/O or A In	Port 1.7. See <a href="#">Section 14</a> for a complete description.

# C8051F330/1/2/3/4/5

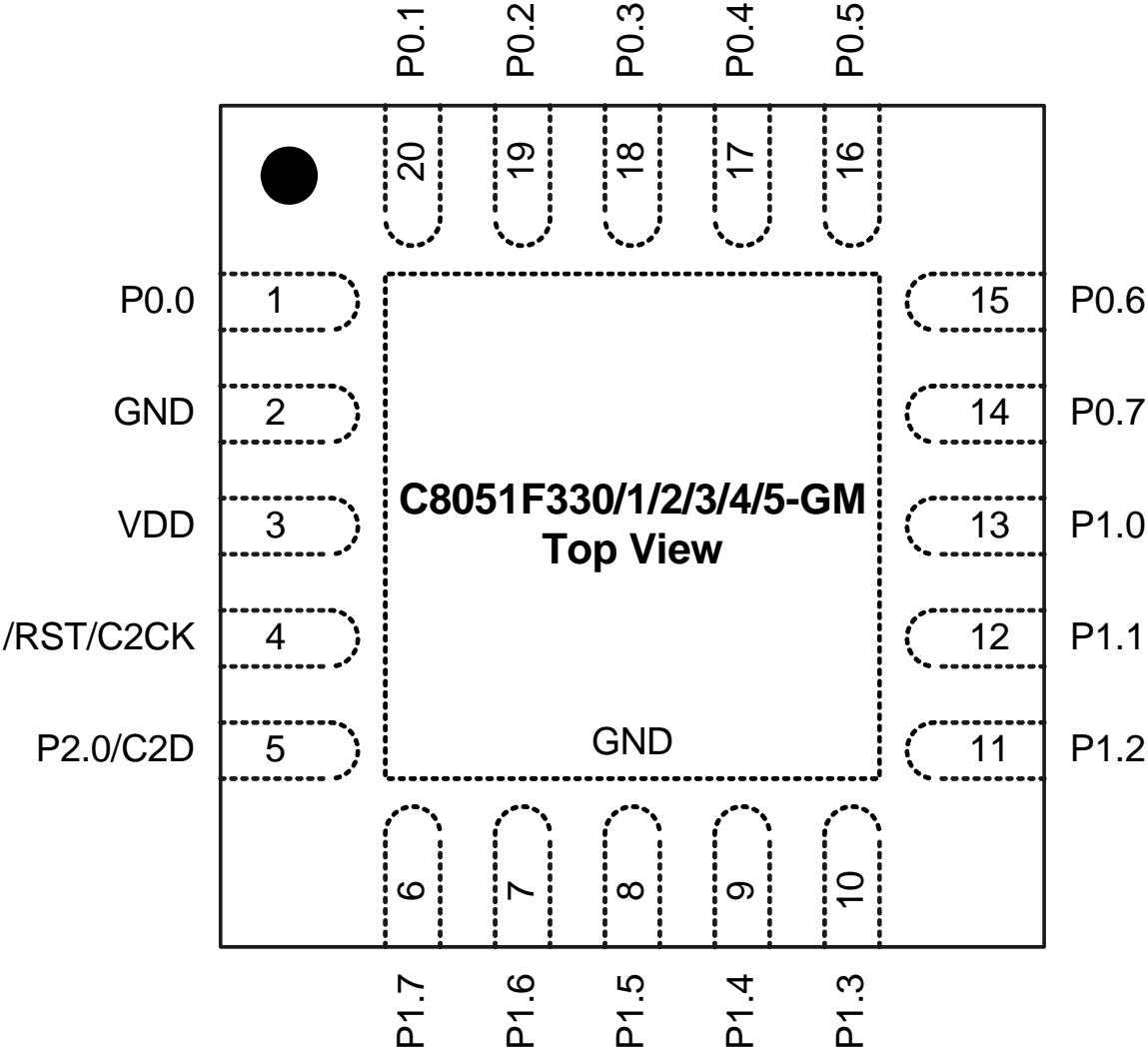
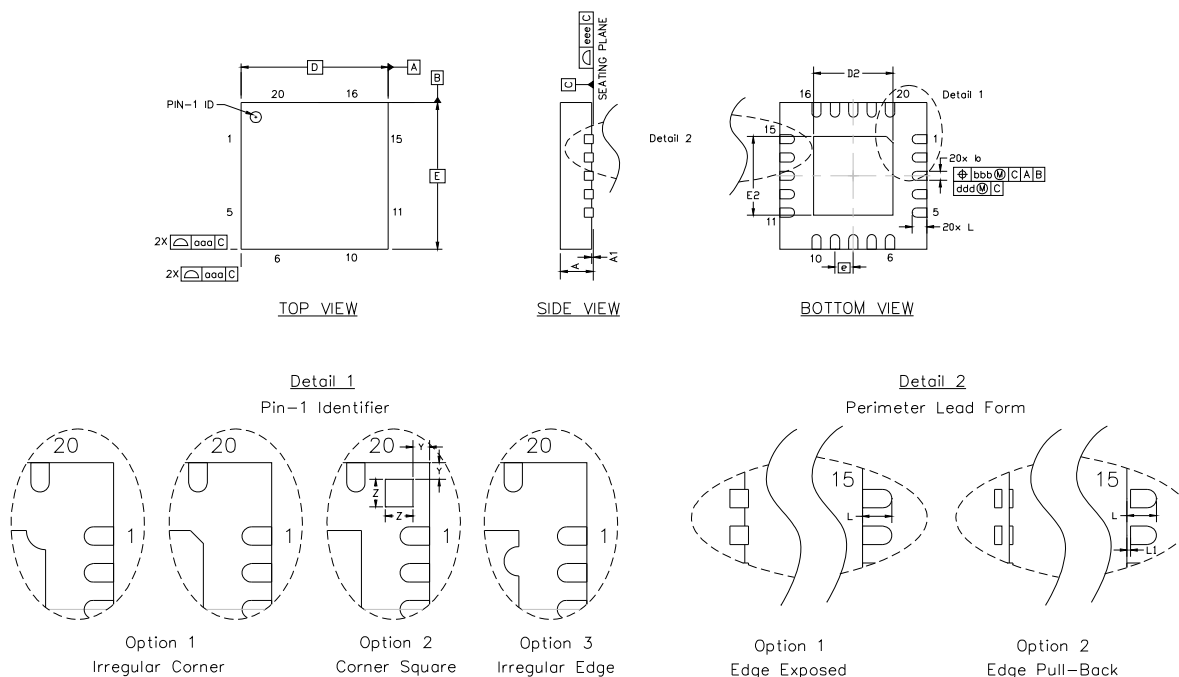

Figure 4.1. QFN-20 Pinout Diagram (Top View)

# C8051F330/1/2/3/4/5



**Figure 4.2. QFN-20 Package Drawing**

**Table 4.2. QFN-20 Package Dimensions**

Dimension	Min	Typ	Max
A	0.80	0.90	1.00
A1	0.00	0.02	0.05
b	0.18	0.23	0.30
D	4.00 BSC.		
D2	2.00	2.15	2.25
e	0.50 BSC.		
E	4.00 BSC.		
E2	2.00	2.15	2.25
L	0.45	0.55	0.65
L1	0.00	—	0.15
aaa	—	—	0.15
bbb	—	—	0.10
ddd	—	—	0.05
eee	—	—	0.08
Z	—	0.43	—
Y	—	0.18	—

**Notes:**

1. All dimensions shown are in millimeters (mm) unless otherwise noted.
2. Dimensioning and Tolerancing per ANSI Y14.5M-1994.
3. This drawing conforms to the JEDEC Solid State Outline MO-220, variation VGGD except for custom features D2, E2, Z, Y, and L which are toleranced per supplier designation.
4. Recommended card reflow profile is per the JEDEC/IPC J-STD-020C specification for Small Body Components.

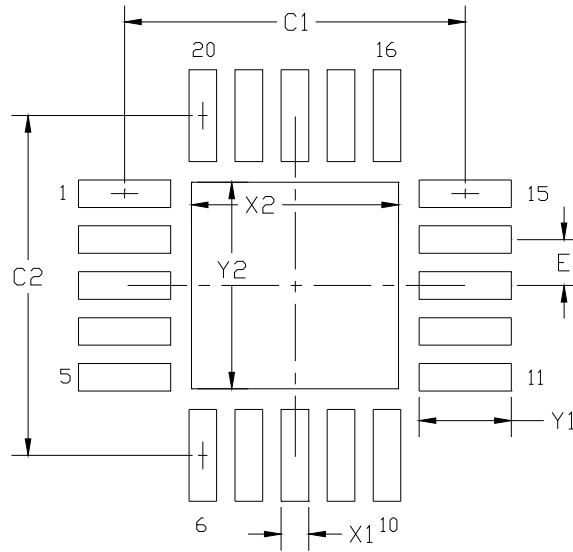

**Figure 4.3. QFN-20 Recommended PCB Land Pattern**

**Table 4.3. QFN-20 PCB Land Pattern Dimensions**

Dimension	Min	Max	Dimension	Min	Max
C1	3.70		X2	2.15	2.25
C2	3.70		Y1	0.90	1.00
E	0.50		Y2	2.15	2.25
X1	0.20	0.30			

**Notes:**

General

1. All dimensions shown are in millimeters (mm) unless otherwise noted.
2. Dimensioning and Tolerancing is per the ANSI Y14.5M-1994 specification.
3. This Land Pattern Design is based on the IPC-7351 guidelines.

Solder Mask Design

4. All metal pads are to be non-solder mask defined (NSMD). Clearance between the solder mask and the metal pad is to be 60  $\mu$ m minimum, all the way around the pad.

Stencil Design

5. A stainless steel, laser-cut and electro-polished stencil with trapezoidal walls should be used to assure good solder paste release.
6. The stencil thickness should be 0.125 mm (5 mils).
7. The ratio of stencil aperture to land pad size should be 1:1 for all perimeter pins.
8. A 2x2 array of 0.95 mm openings on a 1.1 mm pitch should be used for the center pad to assure the proper paste volume (71% Paste Coverage).

Card Assembly

9. A No-Clean, Type-3 solder paste is recommended.
10. The recommended card reflow profile is per the JEDEC/IPC J-STD-020 specification for Small Body Components.

# C8051F330/1/2/3/4/5

---



## 5. 10-Bit ADC (ADC0, C8051F330/2/4 only)

The ADC0 subsystem for the C8051F330/2/4 consists of two analog multiplexers (referred to collectively as AMUX0) with 16 total input selections, and a 200 kpsps, 10-bit successive-approximation-register ADC with integrated track-and-hold and programmable window detector. The AMUX0, data conversion modes, and window detector are all configurable under software control via the Special Function Registers shown in Figure 5.1. ADC0 operates in both Single-ended and Differential modes, and may be configured to measure Ports0-1, the Temperature Sensor output, or  $V_{DD}$  with respect to Ports0-1 or GND. The ADC0 subsystem is enabled only when the AD0EN bit in the ADC0 Control register (ADC0CN) is set to logic 1. The ADC0 subsystem is in low power shutdown when this bit is logic 0.

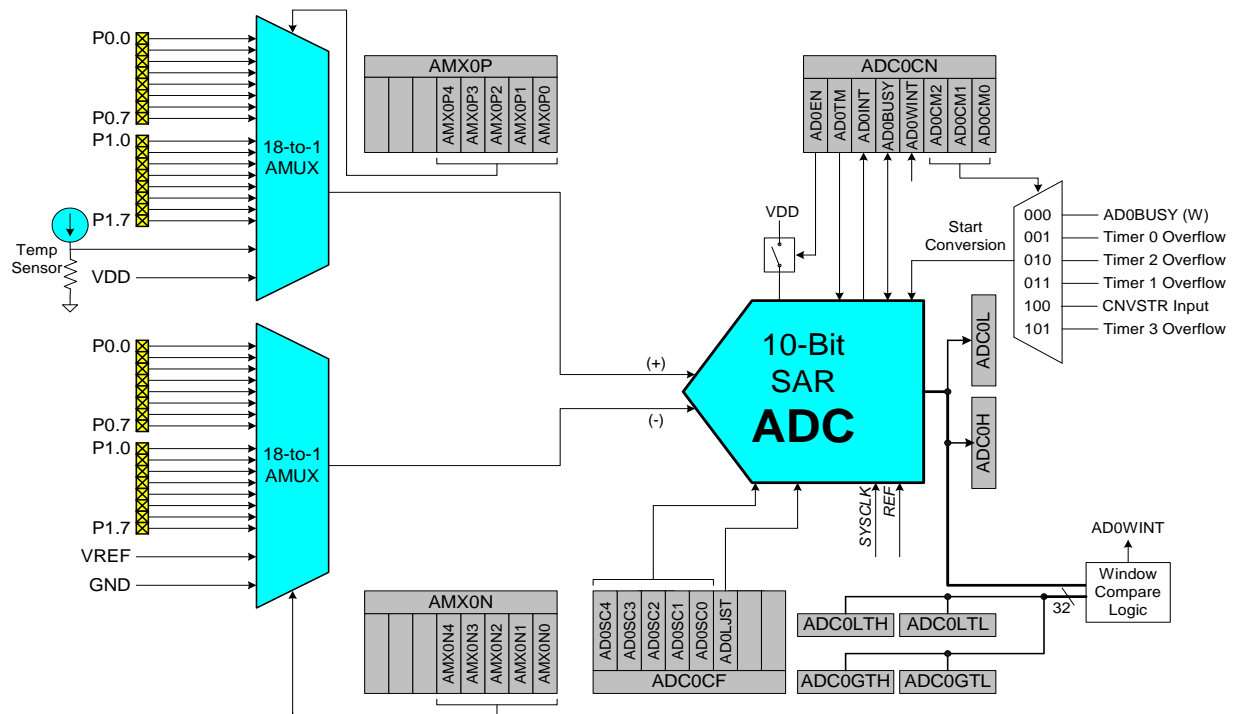

Figure 5.1. ADC0 Functional Block Diagram

### 5.1. Analog Multiplexer

AMUX0 selects the positive and negative inputs to the ADC. Any of the following may be selected as the positive input: Ports0-1, the on-chip temperature sensor, or the positive power supply ( $V_{DD}$ ). Any of the following may be selected as the negative input: Ports0-1,  $V_{REF1}$ , or GND. **When GND is selected as the negative input, ADC0 operates in Single-ended Mode; all other times, ADC0 operates in Differential Mode.** The ADC0 input channels are selected in the AMX0P and AMX0N registers as described in SFR Definition 5.1 and SFR Definition 5.2.

The conversion code format differs between Single-ended and Differential modes. The registers ADC0H and ADC0L contain the high and low bytes of the output conversion code from the ADC at the completion of each conversion. Data can be right-justified or left-justified, depending on the setting of the AD0LJST. When in Single-ended Mode, conversion codes are represented as 10-bit unsigned integers. Inputs are

# C8051F330/1/2/3/4/5

measured from '0' to  $V_{REF} \times 1023/1024$ . Example codes are shown below for both right-justified and left-justified data. Unused bits in the ADC0H and ADC0L registers are set to '0'.

Input Voltage	Right-Justified ADC0H:ADC0L (AD0LJST = 0)	Left-Justified ADC0H:ADC0L (AD0LJST = 1)
$V_{REF} \times 1023/1024$	0x03FF	0xFFC0
$V_{REF} \times 512/1024$	0x0200	0x8000
$V_{REF} \times 256/1024$	0x0100	0x4000
0	0x0000	0x0000

When in Differential Mode, conversion codes are represented as 10-bit signed 2's complement numbers. Inputs are measured from  $-V_{REF}$  to  $V_{REF} \times 511/512$ . Example codes are shown below for both right-justified and left-justified data. For right-justified data, the unused MSBs of ADC0H are a sign-extension of the data word. For left-justified data, the unused LSBs in the ADC0L register are set to '0'.

Input Voltage	Right-Justified ADC0H:ADC0L (AD0LJST = 0)	Left-Justified ADC0H:ADC0L (AD0LJST = 1)
$V_{REF} \times 511/512$	0x01FF	0x7FC0
$V_{REF} \times 256/512$	0x0100	0x4000
0	0x0000	0x0000
$-V_{REF} \times 256/512$	0xFF00	0xC000
$-V_{REF}$	0xFE00	0x8000

**Important Note About ADC0 Input Configuration:** Port pins selected as ADC0 inputs should be configured as analog inputs, and should be skipped by the Digital Crossbar. To configure a Port pin for analog input, set to '0' the corresponding bit in register PnMDIN (for n = 0,1). To force the Crossbar to skip a Port pin, set to '1' the corresponding bit in register PnSKIP (for n = 0,1). See [Section "14. Port Input/Output" on page 123](#) for more Port I/O configuration details.

## 5.2. Temperature Sensor

The typical temperature sensor transfer function is shown in Figure 5.2. The output voltage ( $V_{TEMP}$ ) is the positive ADC input when the temperature sensor is selected by bits AMX0P4–0 in register AMX0P.

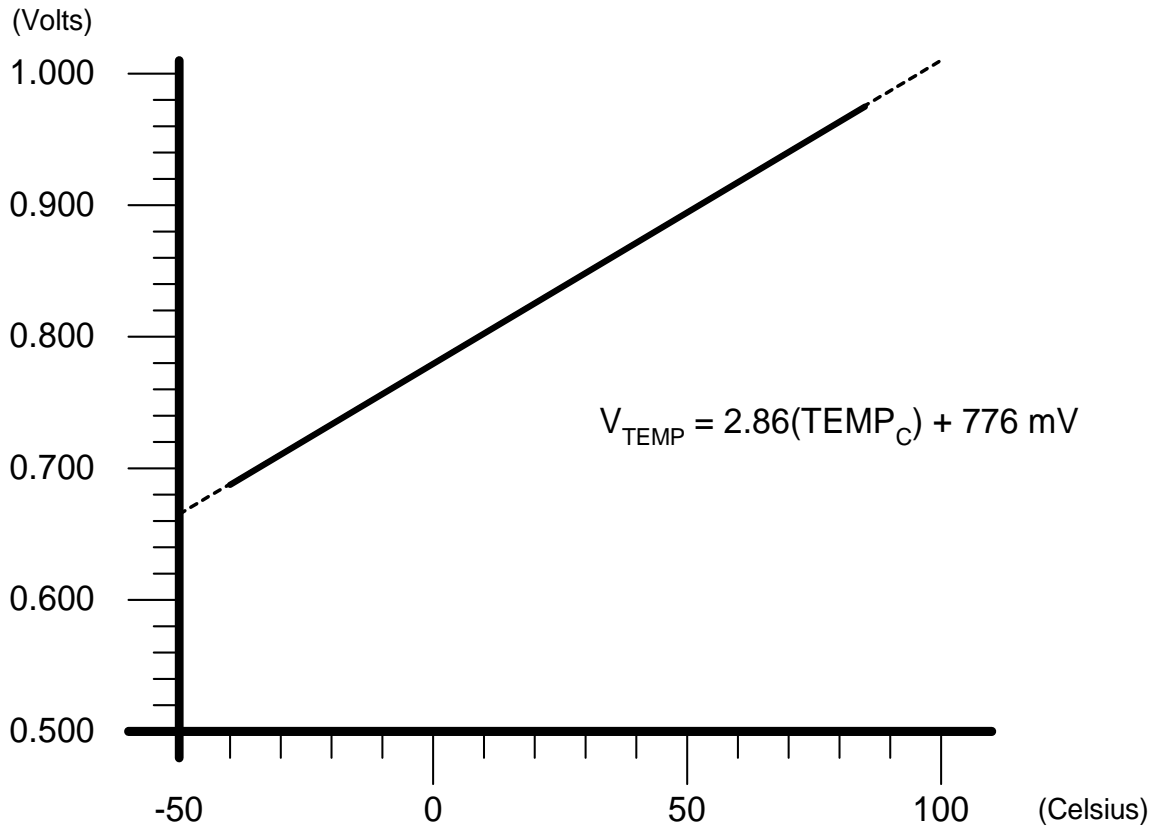

Figure 5.2. Typical Temperature Sensor Transfer Function

### 5.3. Modes of Operation

ADC0 has a maximum conversion speed of 200 ksp/s. The ADC0 conversion clock is a divided version of the system clock, determined by the AD0SC bits in the ADC0CF register (system clock divided by (AD0SC + 1) for  $0 \leq AD0SC \leq 31$ ).

# C8051F330/1/2/3/4/5

---

## 5.3.1. Starting a Conversion

A conversion can be initiated in one of six ways, depending on the programmed states of the ADC0 Start of Conversion Mode bits (AD0CM2–0) in register ADC0CN. Conversions may be initiated by one of the following:

1. Writing a '1' to the AD0BUSY bit of register ADC0CN
2. A Timer 0 overflow (i.e., timed continuous conversions)
3. A Timer 2 overflow
4. A Timer 1 overflow
5. A rising edge on the CNVSTR input signal (pin P0.6)
6. A Timer 3 overflow

Writing a '1' to AD0BUSY provides software control of ADC0 whereby conversions are performed "on-demand". During conversion, the AD0BUSY bit is set to logic 1 and reset to logic 0 when the conversion is complete. The falling edge of AD0BUSY triggers an interrupt (when enabled) and sets the ADC0 interrupt flag (AD0INT). Note: When polling for ADC conversion completions, the ADC0 interrupt flag (AD0INT) should be used. Converted data is available in the ADC0 data registers, ADC0H:ADC0L, when bit AD0INT is logic 1. Note that when Timer 2 or Timer 3 overflows are used as the conversion source, Low Byte overflows are used if Timer 2/3 is in 8-bit mode; High byte overflows are used if Timer 2/3 is in 16-bit mode. See [Section "18. Timers" on page 177](#) for timer configuration.

**Important Note About Using CNVSTR:** The CNVSTR input pin also functions as Port pin P0.6. When the CNVSTR input is used as the ADC0 conversion source, Port pin P0.6 should be skipped by the Digital Crossbar. To configure the Crossbar to skip P0.6, set to '1' Bit6 in register P0SKIP. See [Section "14. Port Input/Output" on page 123](#) for details on Port I/O configuration.

## 5.3.2. Tracking Modes

Each ADC0 conversion must be preceded by a minimum tracking time in order for the converted result to be accurate. The minimum tracking time is given in Table 5.1. The AD0TM bit in register ADC0CN controls the ADC0 track-and-hold mode. In its default state, the ADC0 input is continuously tracked, except when a conversion is in progress. When the AD0TM bit is logic 1, ADC0 operates in low-power track-and-hold mode. In this mode, each conversion is preceded by a tracking period of 3 SAR clocks (after the start-of-conversion signal). When the CNVSTR signal is used to initiate conversions in low-power tracking mode, ADC0 tracks only when CNVSTR is low; conversion begins on the rising edge of CNVSTR (see Figure 5.3). Tracking can also be disabled (shutdown) when the device is in low power standby or sleep modes. Low-power track-and-hold mode is also useful when AMUX settings are frequently changed, due to the settling time requirements described in [Section “5.3.3. Settling Time Requirements” on page 46](#).

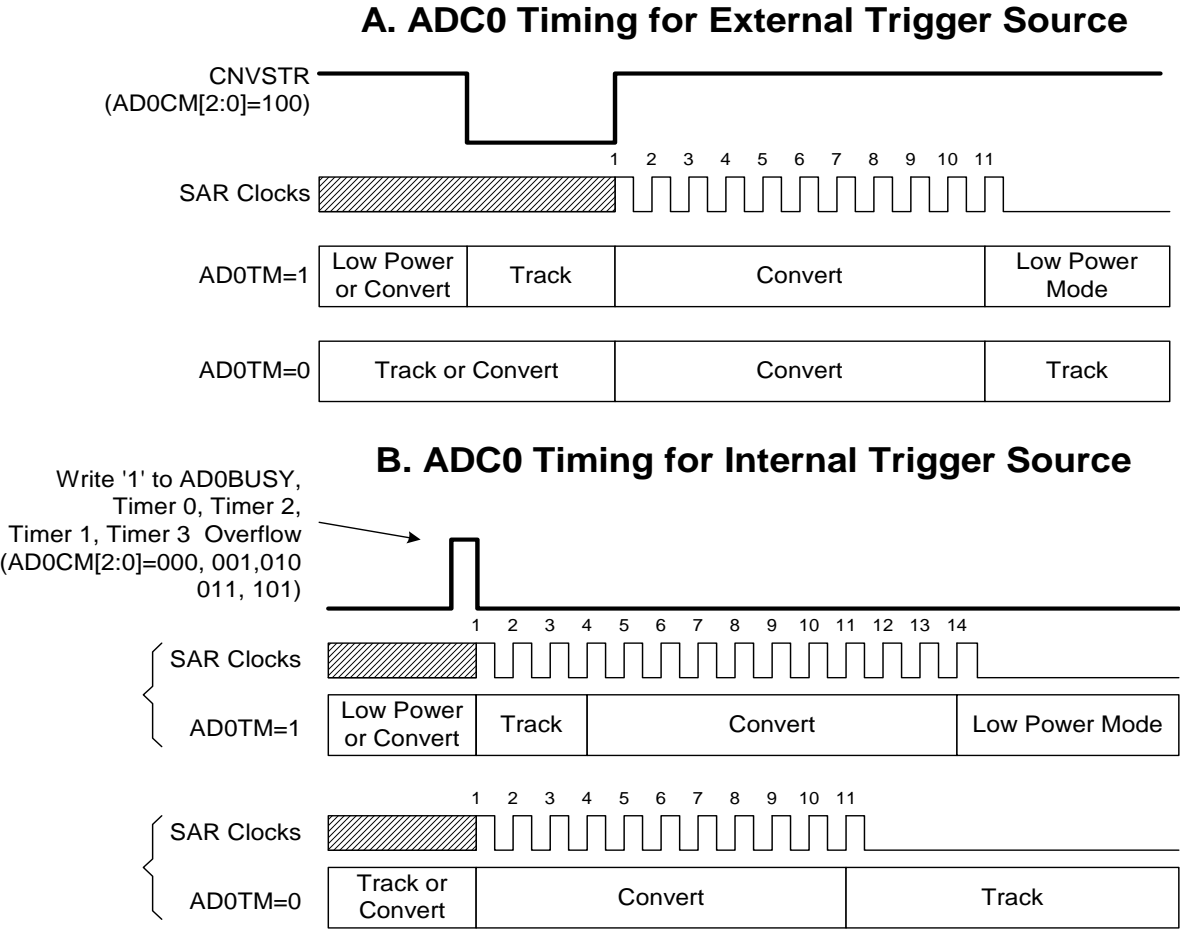

**Figure 5.3. 10-Bit ADC Track and Conversion Example Timing**

## 5.3.3. Settling Time Requirements

When the ADC0 input configuration is changed (i.e., a different AMUX0 selection is made), a minimum tracking time is required before an accurate conversion can be performed. This tracking time is determined by the AMUX0 resistance, the ADC0 sampling capacitance, any external source resistance, and the accuracy required for the conversion. Note that in low-power tracking mode, three SAR clocks are used for tracking at the start of every conversion. For most applications, these three SAR clocks will meet the minimum tracking time requirements.

Figure 5.4 shows the equivalent ADC0 input circuits for both Differential and Single-ended modes. Notice that the equivalent time constant for both input circuits is the same. The required ADC0 settling time for a given settling accuracy (SA) may be approximated by Equation 5.1. When measuring the Temperature Sensor output or  $V_{DD}$  with respect to GND,  $R_{TOTAL}$  reduces to  $R_{MUX}$ . See Table 5.1 for ADC0 minimum settling time requirements.

$$t = \ln\left(\frac{2^n}{SA}\right) \times R_{TOTAL} C_{SAMPLE}$$

### Equation 5.1. ADC0 Settling Time Requirements

Where:

SA is the settling accuracy, given as a fraction of an LSB (for example, 0.25 to settle within 1/4 LSB)

t is the required settling time in seconds

$R_{TOTAL}$  is the sum of the AMUX0 resistance and any external source resistance.

n is the ADC resolution in bits (10).

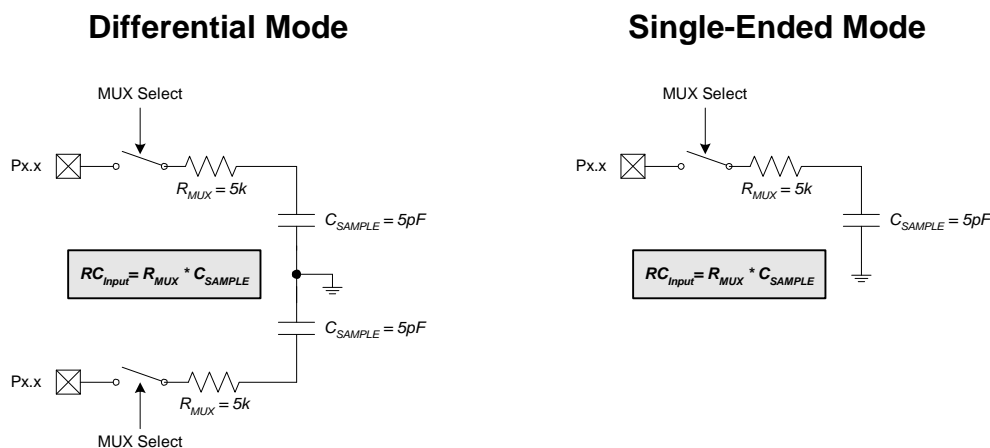

Figure 5.4. ADC0 Equivalent Input Circuits

## SFR Definition 5.1. AMX0P: AMUX0 Positive Channel Select

R	R	R	R/W	R/W	R/W	R/W	R/W	Reset Value
-	-	-	AMX0P4	AMX0P3	AMX0P2	AMX0P1	AMX0P0	00011111
Bit7	Bit6	Bit5	Bit4	Bit3	Bit2	Bit1	Bit0	SFR Address: 0xBB

Bits7–5: UNUSED. Read = 000b; Write = don't care.

Bits4–0: AMX0P4–0: AMUX0 Positive Input Selection

AMX0P4–0	ADC0 Positive Input
00000	P0.0
00001	P0.1
00010	P0.2
00011	P0.3
00100	P0.4
00101	P0.5
00110	P0.6
00111	P0.7
01000	P1.0
01001	P1.1
01010	P1.2
01011	P1.3
01100	P1.4
01101	P1.5
01110	P1.6
01111	P1.7
10000	Temp Sensor
10001	V <sub>DD</sub>
10010 – 11111	no input selected

# C8051F330/1/2/3/4/5

## SFR Definition 5.2. AMX0N: AMUX0 Negative Channel Select

R	R	R	R/W	R/W	R/W	R/W	R/W	Reset Value
-	-	-	AMX0N4	AMX0N3	AMX0N2	AMX0N1	AMX0N0	00011111
Bit7	Bit6	Bit5	Bit4	Bit3	Bit2	Bit1	Bit0	SFR Address: 0xBA

Bits7–5: UNUSED. Read = 000b; Write = don't care.

Bits4–0: AMX0N4–0: AMUX0 Negative Input Selection.

Note that when GND is selected as the Negative Input, ADC0 operates in Single-ended mode. For all other Negative Input selections, ADC0 operates in Differential mode.

AMX0N4–0	ADC0 Negative Input
00000	P0.0
00001	P0.1
00010	P0.2
00011	P0.3
00100	P0.4
00101	P0.5
00110	P0.6
00111	P0.7
01000	P1.0
01001	P1.1
01010	P1.2
01011	P1.3
01100	P1.4
01101	P1.5
01110	P1.6
01111	P1.7
10000	VREF
10001	GND (ADC in Single-Ended Mode)
10010–11111	no input selected



## SFR Definition 5.3. ADC0CF: ADC0 Configuration

R/W	R/W	R/W	R/W	R/W	R/W	R	R	Reset Value
AD0SC4	AD0SC3	AD0SC2	AD0SC1	AD0SC0	AD0LJST	-	-	11111000
Bit7	Bit6	Bit5	Bit4	Bit3	Bit2	Bit1	Bit0	SFR Address: 0xBC

Bits7–3: AD0SC4–0: ADC0 SAR Conversion Clock Period Bits.  
SAR Conversion clock is derived from system clock by the following equation, where AD0SC refers to the 5-bit value held in bits AD0SC4–0. SAR Conversion clock requirements are given in Table 5.1.

$$AD0SC = \frac{SYSCLK}{CLK_{SAR}} - 1$$

Bit2: AD0LJST: ADC0 Left Justify Select.  
0: Data in ADC0H:ADC0L registers are right-justified.  
1: Data in ADC0H:ADC0L registers are left-justified.

Bits1–0: UNUSED. Read = 00b; Write = don't care.

## SFR Definition 5.4. ADC0H: ADC0 Data Word MSB

R/W	R/W	R/W	R/W	R/W	R/W	R/W	R/W	Reset Value
								00000000
Bit7	Bit6	Bit5	Bit4	Bit3	Bit2	Bit1	Bit0	SFR Address: 0xBE

Bits7–0: ADC0 Data Word High-Order Bits.  
For AD0LJST = 0: Bits 7–2 are the sign extension of Bit1. Bits 1–0 are the upper 2 bits of the 10-bit ADC0 Data Word.  
For AD0LJST = 1: Bits 7–0 are the most-significant bits of the 10-bit ADC0 Data Word.

## SFR Definition 5.5. ADC0L: ADC0 Data Word LSB

R/W	R/W	R/W	R/W	R/W	R/W	R/W	R/W	Reset Value
								00000000
Bit7	Bit6	Bit5	Bit4	Bit3	Bit2	Bit1	Bit0	SFR Address: 0xBD

Bits7–0: ADC0 Data Word Low-Order Bits.  
For AD0LJST = 0: Bits 7–0 are the lower 8 bits of the 10-bit Data Word.  
For AD0LJST = 1: Bits 7–6 are the lower 2 bits of the 10-bit Data Word. Bits 5–0 will always read '0'.

# C8051F330/1/2/3/4/5

## SFR Definition 5.6. ADC0CN: ADC0 Control

R/W	R/W	R/W	R/W	R/W	R/W	R/W	R/W	Reset Value
AD0EN	AD0TM	AD0INT	AD0BUSY	AD0WINT	AD0CM2	AD0CM1	AD0CM0	00000000
Bit7	Bit6	Bit5	Bit4	Bit3	Bit2	Bit1	Bit0	SFR Address: 0xE8
								(bit addressable)
Bit7:	AD0EN: ADC0 Enable Bit. 0: ADC0 Disabled. ADC0 is in low-power shutdown. 1: ADC0 Enabled. ADC0 is active and ready for data conversions.							
Bit6:	AD0TM: ADC0 Track Mode Bit. 0: Normal Track Mode: When ADC0 is enabled, tracking is continuous unless a conversion is in progress. 1: Low-power Track Mode: Tracking Defined by AD0CM2–0 bits (see below).							
Bit5:	AD0INT: ADC0 Conversion Complete Interrupt Flag. 0: ADC0 has not completed a data conversion since the last time AD0INT was cleared. 1: ADC0 has completed a data conversion.							
Bit4:	AD0BUSY: ADC0 Busy Bit. Read: 0: ADC0 conversion is complete or a conversion is not currently in progress. AD0INT is set to logic 1 on the falling edge of AD0BUSY. 1: ADC0 conversion is in progress. Write: 0: No Effect. 1: Initiates ADC0 Conversion if AD0CM2–0 = 000b							
Bit3:	AD0WINT: ADC0 Window Compare Interrupt Flag. 0: ADC0 Window Comparison Data match has not occurred since this flag was last cleared. 1: ADC0 Window Comparison Data match has occurred.							
Bits2–0:	AD0CM2–0: ADC0 Start of Conversion Mode Select. When AD0TM = 0: 000: ADC0 conversion initiated on every write of '1' to AD0BUSY. 001: ADC0 conversion initiated on overflow of Timer 0. 010: ADC0 conversion initiated on overflow of Timer 2. 011: ADC0 conversion initiated on overflow of Timer 1. 100: ADC0 conversion initiated on rising edge of external CNVSTR. 101: ADC0 conversion initiated on overflow of Timer 3. 11x: Reserved. When AD0TM = 1: 000: Tracking initiated on write of '1' to AD0BUSY and lasts 3 SAR clocks, followed by conversion. 001: Tracking initiated on overflow of Timer 0 and lasts 3 SAR clocks, followed by conversion. 010: Tracking initiated on overflow of Timer 2 and lasts 3 SAR clocks, followed by conversion. 011: Tracking initiated on overflow of Timer 1 and lasts 3 SAR clocks, followed by conversion. 100: ADC0 tracks only when CNVSTR input is logic low; conversion starts on rising CNVSTR edge. 101: Tracking initiated on overflow of Timer 3 and lasts 3 SAR clocks, followed by conversion. 11x: Reserved.							

## 5.4. Programmable Window Detector

The ADC Programmable Window Detector continuously compares the ADC0 output registers to user-programmed limits, and notifies the system when a desired condition is detected. This is especially effective in an interrupt-driven system, saving code space and CPU bandwidth while delivering faster system response times. The window detector interrupt flag (AD0WINT in register ADC0CN) can also be used in polled mode. The ADC0 Greater-Than (ADC0GTH, ADC0GTL) and Less-Than (ADC0LTH, ADC0LTL) registers hold the comparison values. The window detector flag can be programmed to indicate when measured data is inside or outside of the user-programmed limits, depending on the contents of the ADC0 Less-Than and ADC0 Greater-Than registers.

### SFR Definition 5.7. ADC0GTH: ADC0 Greater-Than Data High Byte

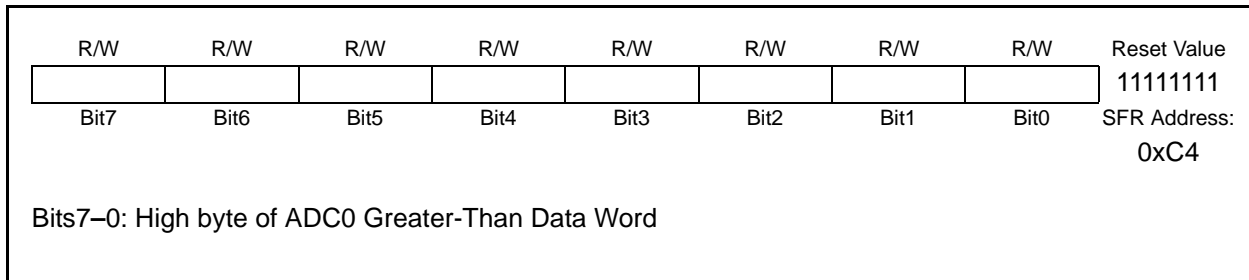

### SFR Definition 5.8. ADC0GTL: ADC0 Greater-Than Data Low Byte

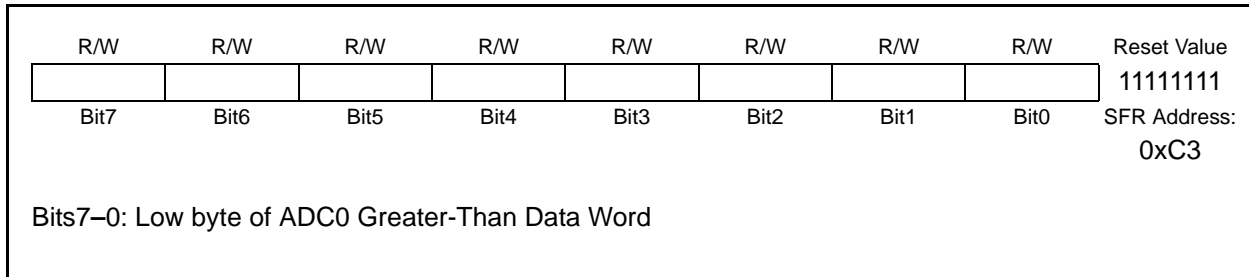

# C8051F330/1/2/3/4/5

## SFR Definition 5.9. ADC0LTH: ADC0 Less-Than Data High Byte

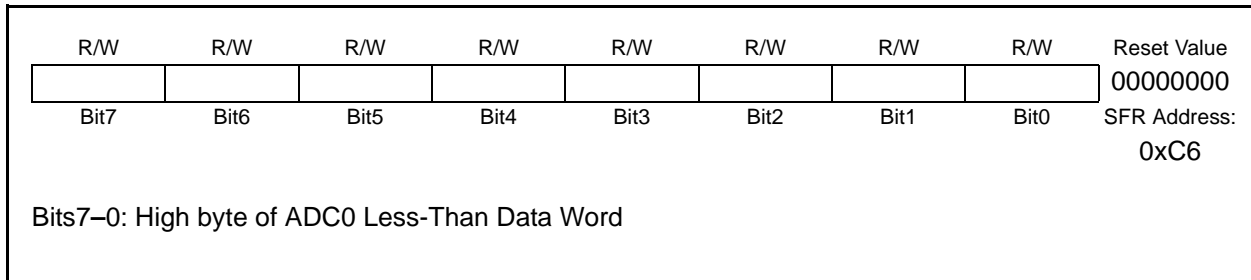

## SFR Definition 5.10. ADC0LTL: ADC0 Less-Than Data Low Byte

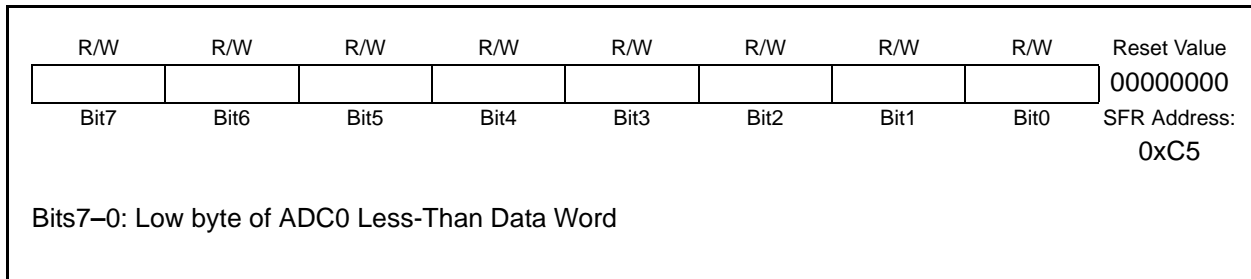

## 5.4.1. Window Detector In Single-Ended Mode

Figure 5.5 shows two example window comparisons for right-justified, single-ended data, with ADC0LTH:ADC0LTL = 0x0080 (128d) and ADC0GTH:ADC0GTL = 0x0040 (64d). In single-ended mode, the input voltage can range from '0' to VREF x (1023/1024) with respect to GND, and is represented by a 10-bit unsigned integer value. In the left example, an AD0WINT interrupt will be generated if the ADC0 conversion word (ADC0H:ADC0L) is within the range defined by ADC0GTH:ADC0GTL and ADC0LTH:ADC0LTL (if  $0x0040 < \text{ADC0H:ADC0L} < 0x0080$ ). In the right example, and AD0WINT interrupt will be generated if the ADC0 conversion word is outside of the range defined by the ADC0GT and ADC0LT registers (if  $\text{ADC0H:ADC0L} < 0x0040$  or  $\text{ADC0H:ADC0L} > 0x0080$ ). Figure 5.6 shows an example using left-justified data with the same comparison values.

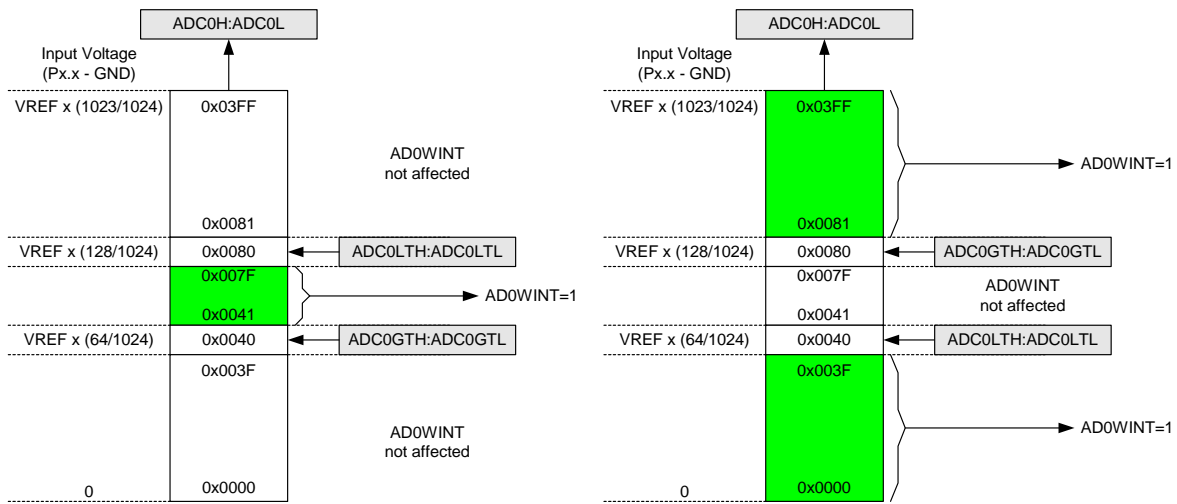

**Figure 5.5. ADC Window Compare Example: Right-Justified Single-Ended Data**

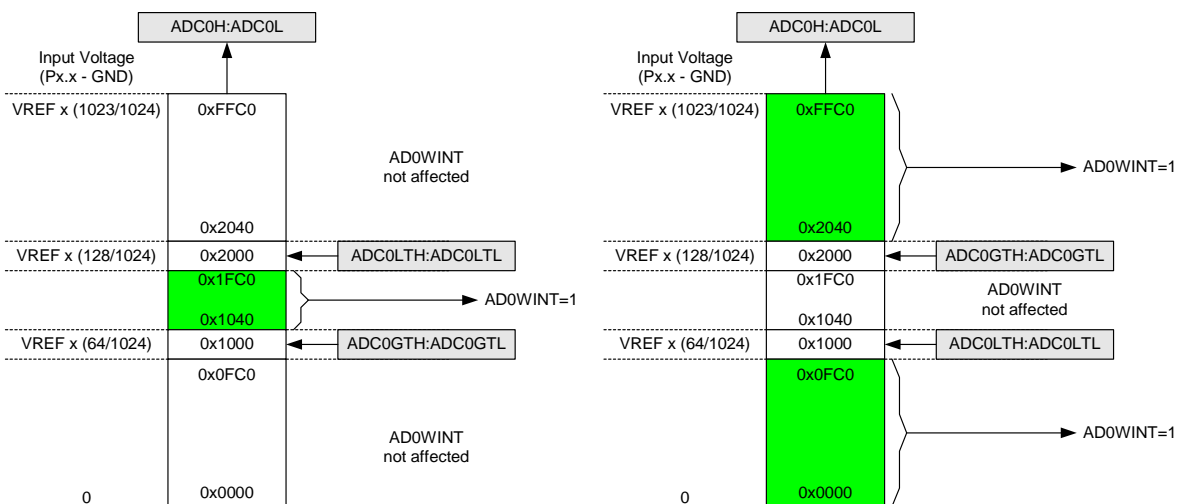

**Figure 5.6. ADC Window Compare Example: Left-Justified Single-Ended Data**

# C8051F330/1/2/3/4/5

## 5.4.2. Window Detector In Differential Mode

Figure 5.7 shows two example window comparisons for right-justified, differential data, with  $ADC0LTH:ADC0LTL = 0x0040 (+64d)$  and  $ADC0GTH:ADC0GTL = 0xFFFF (-1d)$ . In differential mode, the measurable voltage between the input pins is between  $-VREF$  and  $VREF \times (511/512)$ . Output codes are represented as 10-bit 2s complement signed integers. In the left example, an  $AD0WINT$  interrupt will be generated if the  $ADC0$  conversion word ( $ADC0H:ADC0L$ ) is within the range defined by  $ADC0GTH:ADC0GTL$  and  $ADC0LTH:ADC0LTL$  (if  $0xFFFF (-1d) < ADC0H:ADC0L < 0x0040 (64d)$ ). In the right example, an  $AD0WINT$  interrupt will be generated if the  $ADC0$  conversion word is outside of the range defined by the  $ADC0GT$  and  $ADC0LT$  registers (if  $ADC0H:ADC0L < 0xFFFF (-1d)$  or  $ADC0H:ADC0L > 0x0040 (+64d)$ ). Figure 5.8 shows an example using left-justified data with the same comparison values.

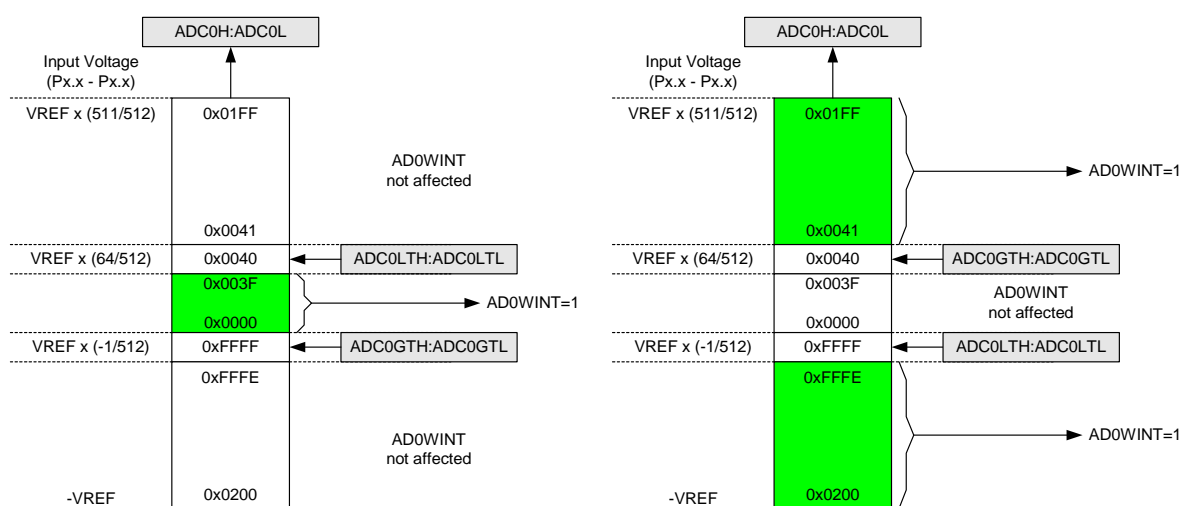

Figure 5.7. ADC Window Compare Example: Right-Justified Differential Data

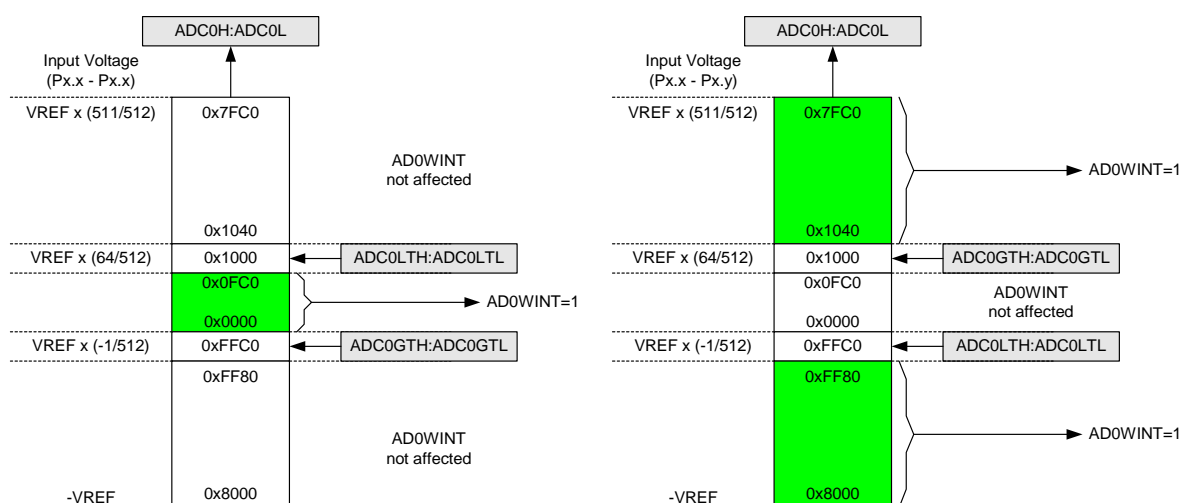

Figure 5.8. ADC Window Compare Example: Left-Justified Differential Data

**Table 5.1. ADC0 Electrical Characteristics**

$V_{DD} = 3.0\text{ V}$ ,  $V_{REF} = 2.40\text{ V}$  (REFSL=0),  $-40$  to  $+85\text{ }^{\circ}\text{C}$  unless otherwise specified.

Parameter	Conditions	Min	Typ	Max	Units
<b>DC Accuracy</b>					
Resolution			10		bits
Integral Nonlinearity		—	$\pm 0.5$	$\pm 1$	LSB
Differential Nonlinearity	Guaranteed Monotonic	—	$\pm 0.5$	$\pm 1$	LSB
Offset Error		-15	0	15	LSB
Full Scale Error		-15	-1	15	LSB
Offset Temperature Coefficient		—	10	—	ppm/ $^{\circ}\text{C}$
<b>Dynamic performance (10 kHz sine-wave single-ended input, 1 dB below Full Scale, 200 ksps)</b>					
Signal-to-Noise Plus Distortion		53	55.5	—	dB
Total Harmonic Distortion	Up to the 5th harmonic	—	-67	—	dB
Spurious-Free Dynamic Range		—	78	—	dB
<b>Conversion Rate</b>					
SAR Conversion Clock		—	—	3	MHz
Conversion Time in SAR Clocks		10	—	—	clocks
Track/Hold Acquisition Time		300	—	—	ns
Throughput Rate		—	—	200	ksps
<b>Analog Inputs</b>					
ADC Input Voltage Range	Single Ended (AIN+ – GND)	0	—	$V_{REF}$	V
	Differential (AIN+ – AIN-)	$-V_{REF}$	—	$V_{REF}$	V
Absolute Pin Voltage with respect to GND	Single Ended or Differential	0	—	$V_{DD}$	V
Input Capacitance		—	5	—	pF
<b>Temperature Sensor</b>					
Linearity		—	$\pm 0.2$	—	$^{\circ}\text{C}$
Absolute Accuracy		—	$\pm 3$	—	$^{\circ}\text{C}$
Gain		—	2.86	—	mV/ $^{\circ}\text{C}$
Gain Error*		—	$\pm 33.5$	—	$\mu\text{V}/^{\circ}\text{C}$
Offset	Temp = $0\text{ }^{\circ}\text{C}$	—	776	—	mV
Offset Error*		—	$\pm 8.51$	—	mV
<b>Power Specifications</b>					
Power Supply Current ( $V_{DD}$ supplied to ADC0)	Operating Mode, 200 ksps	—	400	900	$\mu\text{A}$
Power Supply Rejection		—	$\pm 0.3$	—	mV/V
<b>*Note:</b> Represents one standard deviation from the mean.					

# C8051F330/1/2/3/4/5

---



## 6. 10-Bit Current Mode DAC (IDA0, C8051F330 only)

The C8051F330 device includes a 10-bit current-mode Digital-to-Analog Converter (IDAC). The maximum current output of the IDAC can be adjusted for three different current settings; 0.5 mA, 1 mA, and 2 mA. The IDAC is enabled or disabled with the IDA0EN bit in the IDA0 Control Register (see SFR Definition 6.1). When IDA0EN is set to '0', the IDAC port pin (P0.1) behaves as a normal GPIO pin. When IDA0EN is set to '1', the digital output drivers and weak pullup for the IDAC pin are automatically disabled, and the pin is connected to the IDAC output. An internal bandgap bias generator is used to generate a reference current for the IDAC whenever it is enabled. When using the IDAC, bit 1 in the P0SKIP register should be set to '1', to force the Crossbar to skip the IDAC pin.

### 6.1. IDA0 Output Scheduling

IDA0 features a flexible output update mechanism which allows for seamless full-scale changes and supports jitter-free updates for waveform generation. Three update modes are provided, allowing IDAC output updates on a write to IDA0H, on a Timer overflow, or on an external pin edge.

#### 6.1.1. Update Output On-Demand

In its default mode (IDA0CN.[6:4] = '111') the IDA0 output is updated "on-demand" on a write to the high-byte of the IDA0 data register (IDA0H). It is important to note that writes to IDA0L are held in this mode, and have no effect on the IDA0 output until a write to IDA0H takes place. If writing a full 10-bit word to the IDAC data registers, the 10-bit data word is written to the low byte (IDA0L) and high byte (IDA0H) data registers. Data is latched into IDA0 after a write to the IDA0H register, **so the write sequence should be IDA0L followed by IDA0H** if the full 10-bit resolution is required. The IDAC can be used in 8-bit mode by initializing IDA0L to the desired value (typically 0x00), and writing data to only IDA0H (see [Section 6.2](#) for information on the format of the 10-bit IDAC data word within the 16-bit SFR space).

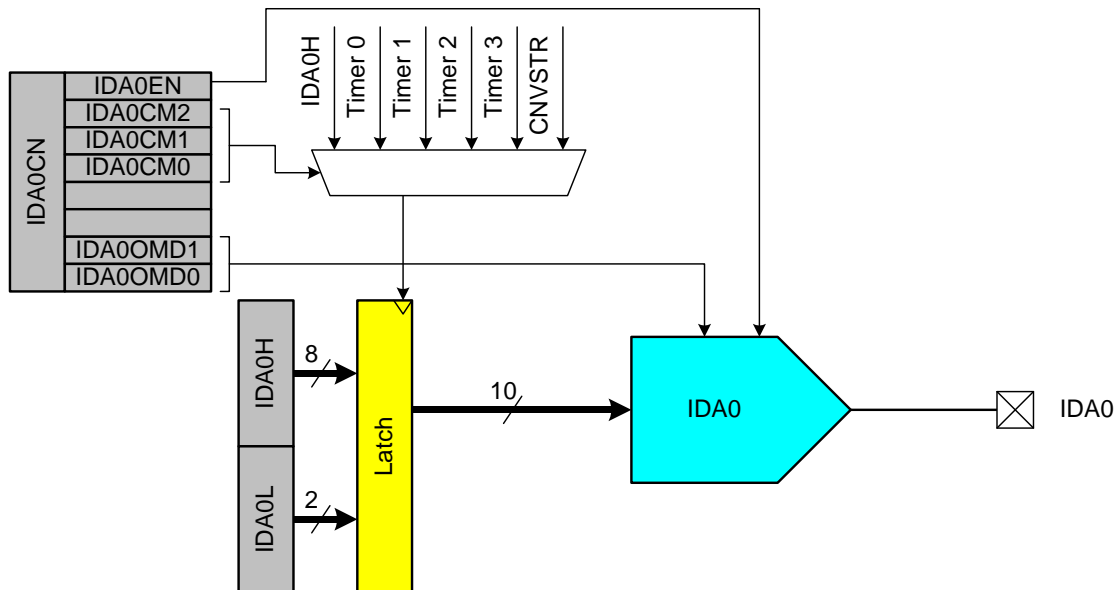

Figure 6.1. IDA0 Functional Block Diagram

# C8051F330/1/2/3/4/5

## 6.1.2. Update Output Based on Timer Overflow

Similar to the ADC operation, in which an ADC conversion can be initiated by a timer overflow independently of the processor, the IDAC outputs can use a Timer overflow to schedule an output update event. This feature is useful in systems where the IDAC is used to generate a waveform of a defined sampling rate by eliminating the effects of variable interrupt latency and instruction execution on the timing of the IDAC output. When the IDA0CM bits (IDA0CN.[6:4]) are set to '000', '001', '010' or '011', writes to both IDAC data registers (IDA0L and IDA0H) are held until an associated Timer overflow event (Timer 0, Timer 1, Timer 2 or Timer 3, respectively) occurs, at which time the IDA0H:IDA0L contents are copied to the IDAC input latches, allowing the IDAC output to change to the new value.

## 6.1.3. Update Output Based on CNVSTR Edge

The IDAC output can also be configured to update on a rising edge, falling edge, or both edges of the external CNVSTR signal. When the IDA0CM bits (IDA0CN.[6:4]) are set to '100', '101', or '110', writes to both IDAC data registers (IDA0L and IDA0H) are held until an edge occurs on the CNVSTR input pin. The particular setting of the IDA0CM bits determines whether IDAC outputs are updated on rising, falling, or both edges of CNVSTR. When a corresponding edge occurs, the IDA0H:IDA0L contents are copied to the IDAC input latches, allowing the IDAC output to change to the new value.

## 6.2. IDAC Output Mapping

The IDAC data registers (IDA0H and IDA0L) are left-justified, meaning that the eight MSBs of the IDAC output word are mapped to bits 7–0 of the IDA0H register, and the two LSBs of the IDAC output word are mapped to bits 7 and 6 of the IDA0L register. The data word mapping for the IDAC is shown in Figure 6.2.

IDA0H								IDA0L											
D9	D8	D7	D6	D5	D4	D3	D2	D1	D0										
<b>Input Data Word (D9–D0)</b>								<b>Output Current</b>											
								<b>IDA0OMD[1:0] = '1x'</b>				<b>IDA0OMD[1:0] = '01'</b>				<b>IDA0OMD[1:0] = '00'</b>			
0x000								0 mA				0 mA				0 mA			
0x001								1/1024 x 2 mA				1/1024 x 1 mA				1/1024 x 0.5 mA			
0x200								512/1024 x 2 mA				512/1024 x 1 mA				512/1024 x 0.5 mA			
0x3FF								1023/1024 x 2 mA				1023/1024 x 1 mA				1023/1024 x 0.5 mA			

**Figure 6.2. IDA0 Data Word Mapping**

The full-scale output current of the IDAC is selected using the IDA0OMD bits (IDA0CN[1:0]). By default, the IDAC is set to a full-scale output current of 2 mA. The IDA0OMD bits can also be configured to provide full-scale output currents of 1 mA or 0.5 mA, as shown in SFR Definition 6.1.

## SFR Definition 6.1. IDA0CN: IDA0 Control

R/W	R/W	R/W	R/W	R	R	R/W	R/W	Reset Value
IDA0EN	IDA0CM			-	-	IDA0OMD		01110010
Bit7	Bit6	Bit5	Bit4	Bit3	Bit2	Bit1	Bit0	SFR Address: 0xB9

Bit 7: IDA0EN: IDA0 Enable.  
 0: IDA0 Disabled.  
 1: IDA0 Enabled.

Bits 6–4: IDA0CM[2:0]: IDA0 Update Source Select bits.  
 000: DAC output updates on Timer 0 overflow.  
 001: DAC output updates on Timer 1 overflow.  
 010: DAC output updates on Timer 2 overflow.  
 011: DAC output updates on Timer 3 overflow.  
 100: DAC output updates on rising edge of CNVSTR.  
 101: DAC output updates on falling edge of CNVSTR.  
 110: DAC output updates on any edge of CNVSTR.  
 111: DAC output updates on write to IDA0H.

Bits 3–2: Unused. Read = 00b. Write = don't care.

Bits 1:0: IDA0OMD[1:0]: IDA0 Output Mode Select bits.  
 00: 0.5 mA full-scale output current.  
 01: 1.0 mA full-scale output current.  
 1x: 2.0 mA full-scale output current.

## SFR Definition 6.2. IDA0H: IDA0 Data Word MSB

R/W	R/W	R/W	R/W	R/W	R/W	R/W	R/W	Reset Value
								00000000
Bit7	Bit6	Bit5	Bit4	Bit3	Bit2	Bit1	Bit0	SFR Address: 0x97

Bits 7–0: IDA0 Data Word High-Order Bits.  
 Bits 7–0 are the most-significant bits of the 10-bit IDA0 Data Word.

# C8051F330/1/2/3/4/5

## SFR Definition 6.3. IDA0L: IDA0 Data Word LSB

R/W	R/W	R	R	R	R	R	R	Reset Value
		—	—	—	—	—	—	00000000
Bit7	Bit6	Bit5	Bit4	Bit3	Bit2	Bit1	Bit0	SFR Address: 0x96

Bits 7–6: IDA0 Data Word Low-Order Bits.  
Lower 2 bits of the 10-bit Data Word.

Bits 5–0: UNUSED. Read = 000000b, Write = don't care.

**Table 6.1. IDAC Electrical Characteristics**

–40 to +85 °C,  $V_{DD} = 3.0$  V Full-scale output current set to 2 mA unless otherwise specified.

Parameter	Conditions	Min	Typ	Max	Units
<b>Static Performance</b>					
Resolution			10		bits
Integral Nonlinearity		—	±0.5	—	LSB
Differential Nonlinearity	Guaranteed Monotonic	—	±0.5	±1	LSB
Output Compliance Range		—	—	$V_{DD} - 1.2$	V
Output Noise	$I_{OUT} = 2$ mA; $R_{LOAD} = 100$ $\Omega$	—	1	—	nA/rHz
Offset Error		—	0	—	LSB
Full Scale Error	2 mA Full Scale Output Current	—	0	—	LSB
Full Scale Error Tempco		—	30	—	ppm/°C
$V_{DD}$ Power Supply Rejection Ratio		—	52	—	dB
Output Capacitance		—	2	—	pF
<b>Dynamic Performance</b>					
Output Settling Time to 1/2 LSB	IDA0H:L = 0x3FF to 0x000	—	5	—	$\mu$ s
Startup Time		—	5	—	$\mu$ s
Gain Variation	1 mA Full Scale Output Current	—	±1	—	%
	0.5 mA Full Scale Output Current	—	±1	—	%
<b>Power Consumption</b>					
Power Supply Current ( $V_{DD}$ supplied to IDAC)	2 mA Full Scale Output Current	—	2100	—	$\mu$ A
	1 mA Full Scale Output Current	—	1100	—	$\mu$ A
	0.5 mA Full Scale Output Current	—	600	—	$\mu$ A

## 7. Voltage Reference (C8051F330/2/4 only)

The Voltage reference MUX on the C8051F330/2/4 devices is configurable to use an externally connected voltage reference, the internal reference voltage generator, or the  $V_{DD}$  power supply voltage (see Figure 7.1). The REFSL bit in the Reference Control register (REF0CN) selects the reference source. For an external source or the internal reference, REFSL should be set to '0'. To use  $V_{DD}$  as the reference source, REFSL should be set to '1'.

The BIASE bit enables the internal voltage bias generator, which is used by the ADC, Temperature Sensor, internal oscillators, and Current DAC. This bias is enabled when any of the aforementioned peripherals are enabled. The bias generator may be enabled manually by writing a '1' to the BIASE bit in register REF0CN; see SFR Definition 7.1 for REF0CN register details. The electrical specifications for the voltage reference circuit are given in Table 7.1.

The internal voltage reference circuit consists of a 1.2 V, temperature stable bandgap voltage reference generator and a gain-of-two output buffer amplifier. The internal voltage reference can be driven out on the VREF pin by setting the REFBE bit in register REF0CN to a '1' (see SFR Definition 7.1). The maximum load seen by the VREF pin must be less than 200  $\mu\text{A}$  to GND. When using the internal voltage reference, bypass capacitors of 0.1  $\mu\text{F}$  and 4.7  $\mu\text{F}$  are recommended from the VREF pin to GND. If the internal reference is not used, the REFBE bit should be cleared to '0'. Electrical specifications for the internal voltage reference are given in Table 7.1.

**Important Note about the VREF Pin:** Port pin P0.0 is used as the external VREF input and as an output for the internal VREF. When using either an external voltage reference or the internal reference circuitry, P0.0 should be configured as an analog pin, and skipped by the Digital Crossbar. To configure P0.0 as an analog pin, set to '0' Bit0 in register P0MDIN. To configure the Crossbar to skip P0.0, set Bit 0 in register P0SKIP to '1'. Refer to [Section "14. Port Input/Output" on page 123](#) for complete Port I/O configuration details. The TEMPE bit in register REF0CN enables/disables the temperature sensor. While disabled, the temperature sensor defaults to a high impedance state and any ADC0 measurements performed on the sensor result in meaningless data.

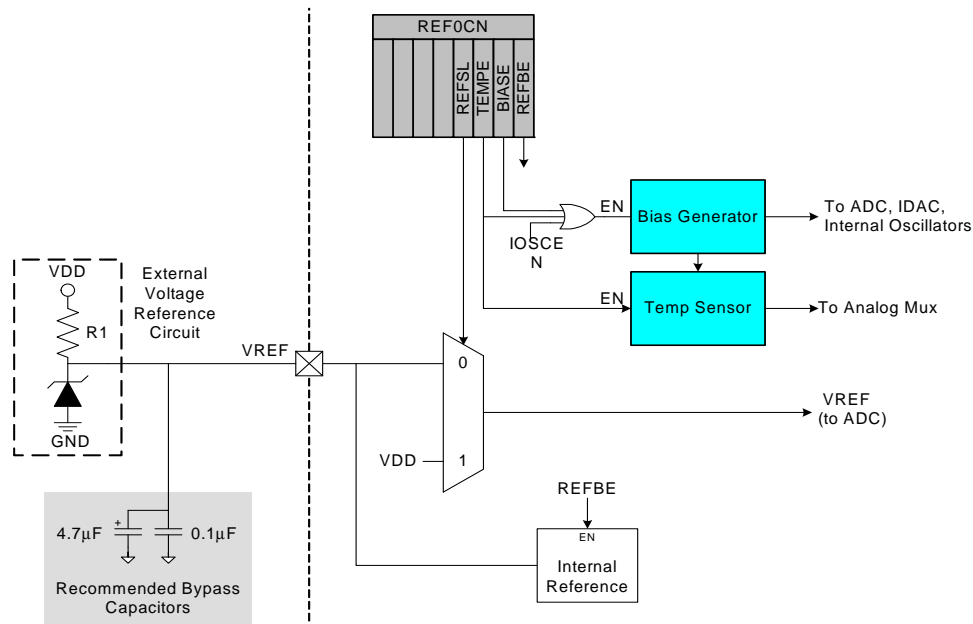

**Figure 7.1. Voltage Reference Functional Block Diagram**

# C8051F330/1/2/3/4/5

## SFR Definition 7.1. REF0CN: Reference Control

R	R	R	R	R/W	R/W	R/W	R/W	Reset Value
-	-	-	-	REFSL	TEMPE	BIASE	REFBE	00000000
Bit7	Bit6	Bit5	Bit4	Bit3	Bit2	Bit1	Bit0	SFR Address: 0xD1

Bits7–4: UNUSED. Read = 0000b; Write = don't care.

Bit3: REFSL: Voltage Reference Select.  
This bit selects the source for the internal voltage reference.  
0: VREF pin used as voltage reference.  
1: V<sub>DD</sub> used as voltage reference.

Bit2: TEMPE: Temperature Sensor Enable Bit.  
0: Internal Temperature Sensor off.  
1: Internal Temperature Sensor on.

Bit1: BIASE: Internal Analog Bias Generator Enable Bit.  
0: Internal Bias Generator off.  
1: Internal Bias Generator on.

Bit0: REFBE: Internal Reference Buffer Enable Bit.  
0: Internal Reference Buffer disabled.  
1: Internal Reference Buffer enabled. Internal voltage reference driven on the VREF pin.

**Table 7.1. Voltage Reference Electrical Characteristics**

$V_{DD} = 3.0\text{ V}$ ;  $-40$  to  $+85\text{ }^{\circ}\text{C}$  unless otherwise specified.

Parameter	Conditions	Min	Typ	Max	Units
<b>Internal Reference (REFBE = 1)</b>					
Output Voltage	25 °C ambient	2.38	2.44	2.50	V
VREF Short-Circuit Current		—	—	10	mA
VREF Temperature Coefficient		—	15	—	ppm/°C
Load Regulation	Load = 0 to 200 $\mu\text{A}$ to AGND	—	0.5	—	ppm/ $\mu\text{A}$
VREF Turn-on Time 1	4.7 $\mu\text{F}$ tantalum, 0.1 $\mu\text{F}$ ceramic bypass	—	2	—	ms
VREF Turn-on Time 2	0.1 $\mu\text{F}$ ceramic bypass	—	20	—	$\mu\text{s}$
VREF Turn-on Time 3	no bypass cap	—	10	—	$\mu\text{s}$
Power Supply Rejection		—	140	—	ppm/V
<b>External Reference (REFBE = 0)</b>					
Input Voltage Range		0	—	$V_{DD}$	V
Input Current	Sample Rate = 200 ksp/s; VREF = 3.0 V	—	12	—	$\mu\text{A}$
<b>Power Specifications</b>					
ADC Bias Generator	BIASE = '1' or AD0EN = '1' or IOSCEN = '1'	—	100	—	$\mu\text{A}$
Reference Bias Generator	REFBE = '1' or TEMPE = '1' or IDA0EN = '1'	—	40	—	$\mu\text{A}$

# C8051F330/1/2/3/4/5

---



## 8. Comparator0

C8051F330/1/2/3/4/5 devices include an on-chip programmable voltage comparator, Comparator0, shown in Figure 8.1.

The Comparator offers programmable response time and hysteresis, an analog input multiplexer, and two outputs that are optionally available at the Port pins: a synchronous “latched” output (CP0), or an asynchronous “raw” output (CP0A). The asynchronous CP0A signal is available even when in when the system clock is not active. This allows the Comparator to operate and generate an output with the device in STOP mode. When assigned to a Port pin, the Comparator output may be configured as open drain or push-pull (see [Section “14.2. Port I/O Initialization” on page 127](#)). Comparator0 may also be used as a reset source (see [Section “10.5. Comparator0 Reset” on page 100](#)).

The Comparator0 inputs are selected in the CPT0MX register (SFR Definition 8.2). The CMX0P1–CMX0P0 bits select the Comparator0 positive input; the CMX0N1–CMX0N0 bits select the Comparator0 negative input. **Important Note About Comparator Inputs:** The Port pins selected as comparator inputs should be configured as analog inputs in their associated Port configuration register, and configured to be skipped by the Crossbar (for details on Port configuration, see [Section “14.3. General Purpose Port I/O” on page 129](#)).

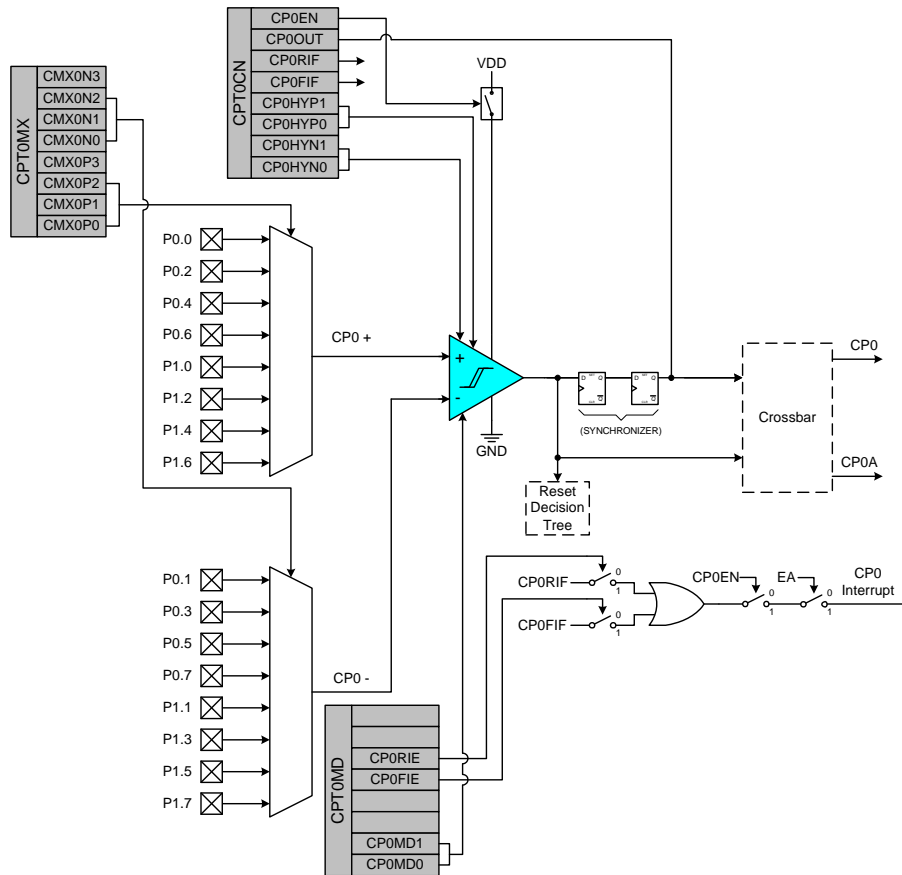
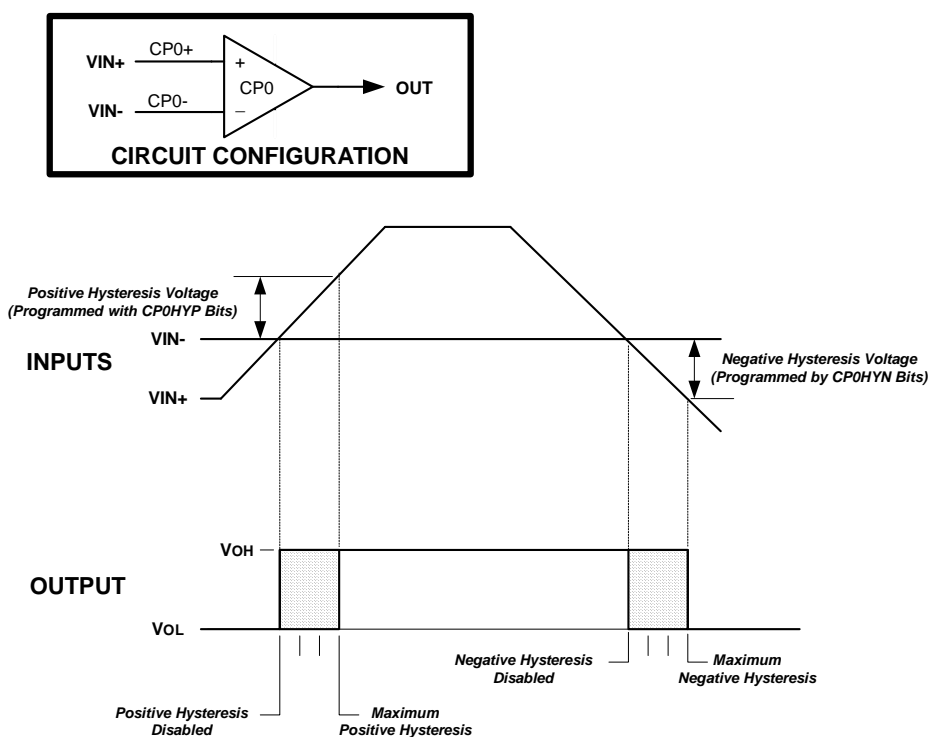

Figure 8.1. Comparator0 Functional Block Diagram

# C8051F330/1/2/3/4/5

The Comparator output can be polled in software, used as an interrupt source, and/or routed to a Port pin. When routed to a Port pin, the Comparator output is available asynchronous or synchronous to the system clock; the asynchronous output is available even in STOP mode (with no system clock active). When disabled, the Comparator output (if assigned to a Port I/O pin via the Crossbar) defaults to the logic low state, and its supply current falls to less than 100 nA. See [Section “14.1. Priority Crossbar Decoder” on page 125](#) for details on configuring Comparator outputs via the digital Crossbar. Comparator inputs can be externally driven from  $-0.25\text{ V}$  to  $(VDD) + 0.25\text{ V}$  without damage or upset. The complete Comparator electrical specifications are given in Table 8.1.

The Comparator response time may be configured in software via the CPT0MD register (see SFR Definition 8.3). Selecting a longer response time reduces the Comparator supply current. See Table 8.1 for complete timing and power consumption specifications.



**Figure 8.2. Comparator Hysteresis Plot**

The Comparator hysteresis is software-programmable via its Comparator Control register CPT0CN. The user can program both the amount of hysteresis voltage (referred to the input voltage) and the positive and negative-going symmetry of this hysteresis around the threshold voltage.

The Comparator hysteresis is programmed using Bits3–0 in the Comparator Control Register CPT0CN (shown in SFR Definition 8.1). The amount of negative hysteresis voltage is determined by the settings of the CP0HYN bits. As shown in Figure 8.2, settings of 20, 10 or 5 mV of negative hysteresis can be programmed, or negative hysteresis can be disabled. In a similar way, the amount of positive hysteresis is determined by the setting the CP0HYP bits.

Comparator interrupts can be generated on both rising-edge and falling-edge output transitions. (For Interrupt enable and priority control, see Section “8.3. Interrupt Handler” on page 58). The CP0FIF flag is set to

logic 1 upon a Comparator falling-edge occurrence, and the CP0RIF flag is set to logic 1 upon the Comparator rising-edge occurrence. Once set, these bits remain set until cleared by software. The Comparator rising-edge interrupt mask is enabled by setting CP0RIE to a logic 1. The Comparator0 falling-edge interrupt mask is enabled by setting CP0FIE to a logic 1.

The output state of the Comparator can be obtained at any time by reading the CP0OUT bit. The Comparator is enabled by setting the CP0EN bit to logic 1, and is disabled by clearing this bit to logic 0.

Note that false rising edges and falling edges can be detected when the comparator is first powered on or if changes are made to the hysteresis or response time control bits. Therefore, it is recommended that the rising-edge and falling-edge flags be explicitly cleared to logic 0 a short time after the comparator is enabled or its mode bits have been changed. This Power Up Time is specified in Table 8.1 on page 70.

## SFR Definition 8.1. CPT0CN: Comparator0 Control

R/W	R	R/W	R/W	R/W	R/W	R/W	R/W	Reset Value
CP0EN	CP0OUT	CP0RIF	CP0FIF	CP0HYP1	CP0HYP0	CP0HYN1	CP0HYN0	00000000
Bit7	Bit6	Bit5	Bit4	Bit3	Bit2	Bit1	Bit0	SFR Address: 0x9B
<p>Bit7: CP0EN: Comparator0 Enable Bit. 0: Comparator0 Disabled. 1: Comparator0 Enabled.</p> <p>Bit6: CP0OUT: Comparator0 Output State Flag. 0: Voltage on CP0+ &lt; CP0-. 1: Voltage on CP0+ &gt; CP0-.</p> <p>Bit5: CP0RIF: Comparator0 Rising-Edge Flag. Must be cleared by software. 0: No Comparator0 Rising Edge has occurred since this flag was last cleared. 1: Comparator0 Rising Edge has occurred.</p> <p>Bit4: CP0FIF: Comparator0 Falling-Edge Flag. Must be cleared by software. 0: No Comparator0 Falling-Edge has occurred since this flag was last cleared. 1: Comparator0 Falling-Edge has occurred.</p> <p>Bits3–2: CP0HYP1–0: Comparator0 Positive Hysteresis Control Bits. 00: Positive Hysteresis Disabled. 01: Positive Hysteresis = 5 mV. 10: Positive Hysteresis = 10 mV. 11: Positive Hysteresis = 20 mV.</p> <p>Bits1–0: CP0HYN1–0: Comparator0 Negative Hysteresis Control Bits. 00: Negative Hysteresis Disabled. 01: Negative Hysteresis = 5 mV. 10: Negative Hysteresis = 10 mV. 11: Negative Hysteresis = 20 mV.</p>								

# C8051F330/1/2/3/4/5

## SFR Definition 8.2. CPT0MX: Comparator0 MUX Selection

R/W	R/W	R/W	R/W	R/W	R/W	R/W	R/W	Reset Value
CMX0N3	CMX0N2	CMX0N1	CMX0N0	CMX0P3	CMX0P2	CMX0P1	CMX0P0	11111111
Bit7	Bit6	Bit5	Bit4	Bit3	Bit2	Bit1	Bit0	SFR Address: 0x9F

Bits7–4: CMX0N3–CMX0N0: Comparator0 Negative Input MUX Select.  
These bits select which Port pin is used as the Comparator0 negative input.

CMX0N3	CMX0N2	CMX0N1	CMX0N0	Negative Input
0	0	0	0	P0.1
0	0	0	1	P0.3
0	0	1	0	P0.5
0	0	1	1	P0.7
0	1	0	0	P1.1
0	1	0	1	P1.3
0	1	1	0	P1.5
0	1	1	1	P1.7
1	x	x	x	None

Bits3–0: CMX0P3–CMX0P0: Comparator0 Positive Input MUX Select.  
These bits select which Port pin is used as the Comparator0 positive input.

CMX0P3	CMX0P2	CMX0P1	CMX0P0	Positive Input
0	0	0	0	P0.0
0	0	0	1	P0.2
0	0	1	0	P0.4
0	0	1	1	P0.6
0	1	0	0	P1.0
0	1	0	1	P1.2
0	1	1	0	P1.4
0	1	1	1	P1.6
1	x	x	x	None

## SFR Definition 8.3. CPT0MD: Comparator0 Mode Selection

R	R	R/W	R/W	R	R	R/W	R/W	Reset Value
-	-	CP0RIE	CP0FIE	-	-	CP0MD1	CP0MD0	00000010
Bit7	Bit6	Bit5	Bit4	Bit3	Bit2	Bit1	Bit0	SFR Address: 0x9D

Bits7–6: UNUSED. Read = 00b, Write = don't care.

Bit5: CP0RIE: Comparator0 Rising-Edge Interrupt Enable.  
0: Comparator0 Rising-edge interrupt disabled.  
1: Comparator0 Rising-edge interrupt enabled.

Bit4: CP0FIE: Comparator0 Falling-Edge Interrupt Enable.  
0: Comparator0 Falling-edge interrupt disabled.  
1: Comparator0 Falling-edge interrupt enabled.

Bits3–2: UNUSED. Read = 00b, Write = don't care.

Bits1–0: CP0MD1–CP0MD0: Comparator0 Mode Select  
These bits select the response time for Comparator0.

Mode	CP0MD1	CP0MD0	CP0 Response Time (TYP)
0	0	0	100 ns
1	0	1	175 ns
2	1	0	320 ns
3	1	1	1050 ns

# C8051F330/1/2/3/4/5

**Table 8.1. Comparator Electrical Characteristics**

$V_{DD} = 3.0\text{ V}$ ,  $-40$  to  $+85\text{ }^{\circ}\text{C}$  unless otherwise noted.

Parameter	Conditions	Min	Typ	Max	Units
Response Time: Mode 0, $V_{cm}^* = 1.5\text{ V}$	$CP0+ - CP0- = 100\text{ mV}$	—	100	—	ns
	$CP0+ - CP0- = -100\text{ mV}$	—	250	—	ns
Response Time: Mode 1, $V_{cm}^* = 1.5\text{ V}$	$CP0+ - CP0- = 100\text{ mV}$	—	175	—	ns
	$CP0+ - CP0- = -100\text{ mV}$	—	500	—	ns
Response Time: Mode 2, $V_{cm}^* = 1.5\text{ V}$	$CP0+ - CP0- = 100\text{ mV}$	—	320	—	ns
	$CP0+ - CP0- = -100\text{ mV}$	—	1100	—	ns
Response Time: Mode 3, $V_{cm}^* = 1.5\text{ V}$	$CP0+ - CP0- = 100\text{ mV}$	—	1050	—	ns
	$CP0+ - CP0- = -100\text{ mV}$	—	5200	—	ns
Common-Mode Rejection Ratio		—	1.5	4	mV/V
Positive Hysteresis 1	$CP0HYP1-0 = 00$	—	0	1	mV
Positive Hysteresis 2	$CP0HYP1-0 = 01$	2	5	10	mV
Positive Hysteresis 3	$CP0HYP1-0 = 10$	7	10	20	mV
Positive Hysteresis 4	$CP0HYP1-0 = 11$	15	20	30	mV
Negative Hysteresis 1	$CP0HYN1-0 = 00$	—	0	1	mV
Negative Hysteresis 2	$CP0HYN1-0 = 01$	2	5	10	mV
Negative Hysteresis 3	$CP0HYN1-0 = 10$	7	10	20	mV
Negative Hysteresis 4	$CP0HYN1-0 = 11$	15	20	30	mV
Inverting or Non-Inverting Input Voltage Range		-0.25	—	$V_{DD} + 0.25$	V
Input Capacitance		—	4	—	pF
Input Bias Current		—	0.001	—	nA
Input Offset Voltage		-5	—	+5	mV
<b>Power Supply</b>					
Power Supply Rejection		—	0.1	—	mV/V
Power-up Time		—	10	—	$\mu\text{s}$
Supply Current at DC	Mode 0	—	7.6	—	$\mu\text{A}$
	Mode 1	—	3.2	—	$\mu\text{A}$
	Mode 2	—	1.3	—	$\mu\text{A}$
	Mode 3	—	0.4	—	$\mu\text{A}$
<b>*Note:</b> $V_{cm}$ is the common-mode voltage on $CP0+$ and $CP0-$ .					

## 9. CIP-51 Microcontroller

The MCU system controller core is the CIP-51 microcontroller. The CIP-51 is fully compatible with the MCS-51™ instruction set; standard 803x/805x assemblers and compilers can be used to develop software. The MCU family has a superset of all the peripherals included with a standard 8051. Included are four 16-bit counter/timers (see description in [Section 18](#)), an enhanced full-duplex UART (see description in [Section 16](#)), an Enhanced SPI (see description in [Section 17](#)), 256 bytes of internal RAM, 128 byte Special Function Register (SFR) address space ([Section 9.2.6](#)), and 17 Port I/O (see description in [Section 14](#)). The CIP-51 also includes on-chip debug hardware (see description in [Section 20](#)), and interfaces directly with the analog and digital subsystems providing a complete data acquisition or control-system solution in a single integrated circuit.

The CIP-51 Microcontroller core implements the standard 8051 organization and peripherals as well as additional custom peripherals and functions to extend its capability (see Figure 9.1 for a block diagram). The CIP-51 includes the following features:

- Fully Compatible with MCS-51 Instruction Set
- 25 MIPS Peak Throughput with 25 MHz Clock
- 0 to 25 MHz Clock Frequency
- 256 Bytes of Internal RAM
- 17 Port I/O
- Extended Interrupt Handler
- Reset Input
- Power Management Modes

### Performance

The CIP-51 employs a pipelined architecture that greatly increases its instruction throughput over the standard 8051 architecture. In a standard 8051, all instructions except for MUL and DIV take 12 or 24 system clock cycles to execute, and usually have a maximum system clock of 12 MHz. By contrast, the CIP-51 core executes 70% of its instructions in one or two system clock cycles, with no instructions taking more than eight system clock cycles.

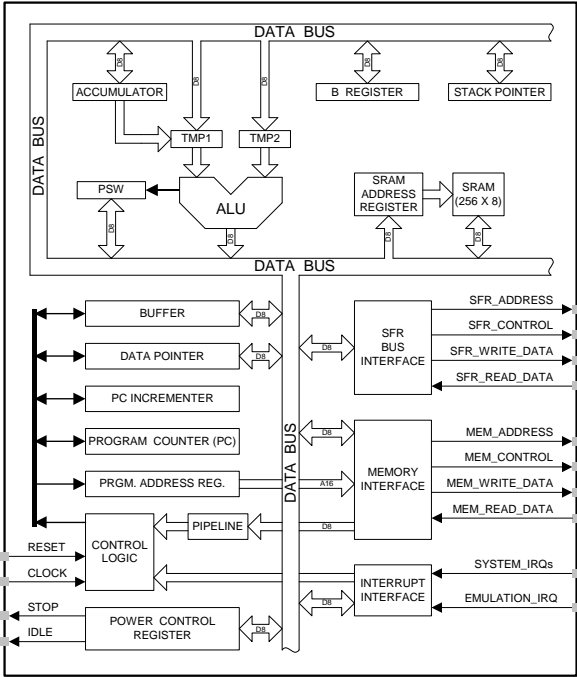

Figure 9.1. CIP-51 Block Diagram

# C8051F330/1/2/3/4/5

With the CIP-51's maximum system clock at 25 MHz, it has a peak throughput of 25 MIPS. The CIP-51 has a total of 109 instructions. The table below shows the total number of instructions that require each execution time.

Clocks to Execute	1	2	2/3	3	3/4	4	4/5	5	8
Number of Instructions	26	50	5	14	7	3	1	2	1

## Programming and Debugging Support

In-system programming of the Flash program memory and communication with on-chip debug support logic is accomplished via the Silicon Labs 2-Wire Development Interface (C2). Note that the re-programmable Flash can also be read and changed a single byte at a time by the application software using the MOVC and MOVX instructions. This feature allows program memory to be used for non-volatile data storage as well as updating program code under software control.

The on-chip debug support logic facilitates full speed in-circuit debugging, allowing the setting of hardware breakpoints, starting, stopping and single stepping through program execution (including interrupt service routines), examination of the program's call stack, and reading/writing the contents of registers and memory. This method of on-chip debugging is completely non-intrusive, requiring no RAM, Stack, timers, or other on-chip resources. C2 details can be found in [Section "20. C2 Interface" on page 209](#).

The CIP-51 is supported by development tools from Silicon Labs and third party vendors. Silicon Labs provides an integrated development environment (IDE) including editor, macro assembler, debugger and programmer. The IDE's debugger and programmer interface to the CIP-51 via the C2 interface to provide fast and efficient in-system device programming and debugging. Third party macro assemblers and C compilers are also available.

## 9.1. Instruction Set

The instruction set of the CIP-51 System Controller is fully compatible with the standard MCS-51™ instruction set. Standard 8051 development tools can be used to develop software for the CIP-51. All CIP-51 instructions are the binary and functional equivalent of their MCS-51™ counterparts, including opcodes, addressing modes and effect on PSW flags. However, instruction timing is different than that of the standard 8051.

### 9.1.1. Instruction and CPU Timing

In many 8051 implementations, a distinction is made between machine cycles and clock cycles, with machine cycles varying from 2 to 12 clock cycles in length. However, the CIP-51 implementation is based solely on clock cycle timing. All instruction timings are specified in terms of clock cycles.

Due to the pipelined architecture of the CIP-51, most instructions execute in the same number of clock cycles as there are program bytes in the instruction. Conditional branch instructions take one less clock cycle to complete when the branch is not taken as opposed to when the branch is taken. Table 9.1 is the CIP-51 Instruction Set Summary, which includes the mnemonic, number of bytes, and number of clock cycles for each instruction.

### 9.1.2. MOVX Instruction and Program Memory

The MOVX instruction is typically used to access external data memory (Note: the C8051F330/1/2/3/4/5 does not support off-chip data or program memory). In the CIP-51, the MOVX instruction can be used to access on-chip XRAM or on-chip program memory space implemented as re-programmable Flash memory. The Flash access feature provides a mechanism for the CIP-51 to update program code and use the



program memory space for non-volatile data storage. Refer to [Section “11. Flash Memory” on page 103](#) for further details.

**Table 9.1. CIP-51 Instruction Set Summary**

Mnemonic	Description	Bytes	Clock Cycles
<b>Arithmetic Operations</b>			
ADD A, Rn	Add register to A	1	1
ADD A, direct	Add direct byte to A	2	2
ADD A, @Ri	Add indirect RAM to A	1	2
ADD A, #data	Add immediate to A	2	2
ADDC A, Rn	Add register to A with carry	1	1
ADDC A, direct	Add direct byte to A with carry	2	2
ADDC A, @Ri	Add indirect RAM to A with carry	1	2
ADDC A, #data	Add immediate to A with carry	2	2
SUBB A, Rn	Subtract register from A with borrow	1	1
SUBB A, direct	Subtract direct byte from A with borrow	2	2
SUBB A, @Ri	Subtract indirect RAM from A with borrow	1	2
SUBB A, #data	Subtract immediate from A with borrow	2	2
INC A	Increment A	1	1
INC Rn	Increment register	1	1
INC direct	Increment direct byte	2	2
INC @Ri	Increment indirect RAM	1	2
DEC A	Decrement A	1	1
DEC Rn	Decrement register	1	1
DEC direct	Decrement direct byte	2	2
DEC @Ri	Decrement indirect RAM	1	2
INC DPTR	Increment Data Pointer	1	1
MUL AB	Multiply A and B	1	4
DIV AB	Divide A by B	1	8
DA A	Decimal adjust A	1	1
<b>Logical Operations</b>			
ANL A, Rn	AND Register to A	1	1
ANL A, direct	AND direct byte to A	2	2
ANL A, @Ri	AND indirect RAM to A	1	2
ANL A, #data	AND immediate to A	2	2
ANL direct, A	AND A to direct byte	2	2
ANL direct, #data	AND immediate to direct byte	3	3
ORL A, Rn	OR Register to A	1	1
ORL A, direct	OR direct byte to A	2	2
ORL A, @Ri	OR indirect RAM to A	1	2
ORL A, #data	OR immediate to A	2	2
ORL direct, A	OR A to direct byte	2	2
ORL direct, #data	OR immediate to direct byte	3	3
XRL A, Rn	Exclusive-OR Register to A	1	1
XRL A, direct	Exclusive-OR direct byte to A	2	2
XRL A, @Ri	Exclusive-OR indirect RAM to A	1	2

# C8051F330/1/2/3/4/5

**Table 9.1. CIP-51 Instruction Set Summary (Continued)**

Mnemonic	Description	Bytes	Clock Cycles
XRL A, #data	Exclusive-OR immediate to A	2	2
XRL direct, A	Exclusive-OR A to direct byte	2	2
XRL direct, #data	Exclusive-OR immediate to direct byte	3	3
CLR A	Clear A	1	1
CPL A	Complement A	1	1
RL A	Rotate A left	1	1
RLC A	Rotate A left through Carry	1	1
RR A	Rotate A right	1	1
RRC A	Rotate A right through Carry	1	1
SWAP A	Swap nibbles of A	1	1
<b>Data Transfer</b>			
MOV A, Rn	Move Register to A	1	1
MOV A, direct	Move direct byte to A	2	2
MOV A, @Ri	Move indirect RAM to A	1	2
MOV A, #data	Move immediate to A	2	2
MOV Rn, A	Move A to Register	1	1
MOV Rn, direct	Move direct byte to Register	2	2
MOV Rn, #data	Move immediate to Register	2	2
MOV direct, A	Move A to direct byte	2	2
MOV direct, Rn	Move Register to direct byte	2	2
MOV direct, direct	Move direct byte to direct byte	3	3
MOV direct, @Ri	Move indirect RAM to direct byte	2	2
MOV direct, #data	Move immediate to direct byte	3	3
MOV @Ri, A	Move A to indirect RAM	1	2
MOV @Ri, direct	Move direct byte to indirect RAM	2	2
MOV @Ri, #data	Move immediate to indirect RAM	2	2
MOV DPTR, #data16	Load DPTR with 16-bit constant	3	3
MOVC A, @A+DPTR	Move code byte relative DPTR to A	1	3
MOVC A, @A+PC	Move code byte relative PC to A	1	3
MOVX A, @Ri	Move external data (8-bit address) to A	1	3
MOVX @Ri, A	Move A to external data (8-bit address)	1	3
MOVX A, @DPTR	Move external data (16-bit address) to A	1	3
MOVX @DPTR, A	Move A to external data (16-bit address)	1	3
PUSH direct	Push direct byte onto stack	2	2
POP direct	Pop direct byte from stack	2	2
XCH A, Rn	Exchange Register with A	1	1
XCH A, direct	Exchange direct byte with A	2	2
XCH A, @Ri	Exchange indirect RAM with A	1	2
XCHD A, @Ri	Exchange low nibble of indirect RAM with A	1	2
<b>Boolean Manipulation</b>			
CLR C	Clear Carry	1	1
CLR bit	Clear direct bit	2	2
SETB C	Set Carry	1	1
SETB bit	Set direct bit	2	2

**Table 9.1. CIP-51 Instruction Set Summary (Continued)**

Mnemonic	Description	Bytes	Clock Cycles
CPL C	Complement Carry	1	1
CPL bit	Complement direct bit	2	2
ANL C, bit	AND direct bit to Carry	2	2
ANL C, /bit	AND complement of direct bit to Carry	2	2
ORL C, bit	OR direct bit to carry	2	2
ORL C, /bit	OR complement of direct bit to Carry	2	2
MOV C, bit	Move direct bit to Carry	2	2
MOV bit, C	Move Carry to direct bit	2	2
JC rel	Jump if Carry is set	2	2/3
JNC rel	Jump if Carry is not set	2	2/3
JB bit, rel	Jump if direct bit is set	3	3/4
JNB bit, rel	Jump if direct bit is not set	3	3/4
JBC bit, rel	Jump if direct bit is set and clear bit	3	3/4
<b>Program Branching</b>			
ACALL addr11	Absolute subroutine call	2	3
LCALL addr16	Long subroutine call	3	4
RET	Return from subroutine	1	5
RETI	Return from interrupt	1	5
AJMP addr11	Absolute jump	2	3
LJMP addr16	Long jump	3	4
SJMP rel	Short jump (relative address)	2	3
JMP @A+DPTR	Jump indirect relative to DPTR	1	3
JZ rel	Jump if A equals zero	2	2/3
JNZ rel	Jump if A does not equal zero	2	2/3
CJNE A, direct, rel	Compare direct byte to A and jump if not equal	3	3/4
CJNE A, #data, rel	Compare immediate to A and jump if not equal	3	3/4
CJNE Rn, #data, rel	Compare immediate to Register and jump if not equal	3	3/4
CJNE @Ri, #data, rel	Compare immediate to indirect and jump if not equal	3	4/5
DJNZ Rn, rel	Decrement Register and jump if not zero	2	2/3
DJNZ direct, rel	Decrement direct byte and jump if not zero	3	3/4
NOP	No operation	1	1

# C8051F330/1/2/3/4/5

## Notes on Registers, Operands and Addressing Modes:

**Rn** - Register R0–R7 of the currently selected register bank.

**@Ri** - Data RAM location addressed indirectly through R0 or R1.

**rel** - 8-bit, signed (two's complement) offset relative to the first byte of the following instruction. Used by SJMP and all conditional jumps.

**direct** - 8-bit internal data location's address. This could be a direct-access Data RAM location (0x00–0x7F) or an SFR (0x80–0xFF).

**#data** - 8-bit constant

**#data16** - 16-bit constant

**bit** - Direct-accessed bit in Data RAM or SFR

**addr11** - 11-bit destination address used by ACALL and AJMP. The destination must be within the same 2 kB page of program memory as the first byte of the following instruction.

**addr16** - 16-bit destination address used by LCALL and LJMP. The destination may be anywhere within the 8 kB program memory space.

There is one unused opcode (0xA5) that performs the same function as NOP.  
All mnemonics copyrighted © Intel Corporation 1980.

## 9.2. Memory Organization

The memory organization of the CIP-51 System Controller is similar to that of a standard 8051. There are two separate memory spaces: program memory and data memory. Program and data memory share the same address space but are accessed via different instruction types. The CIP-51 memory organization is shown in Figure 9.2

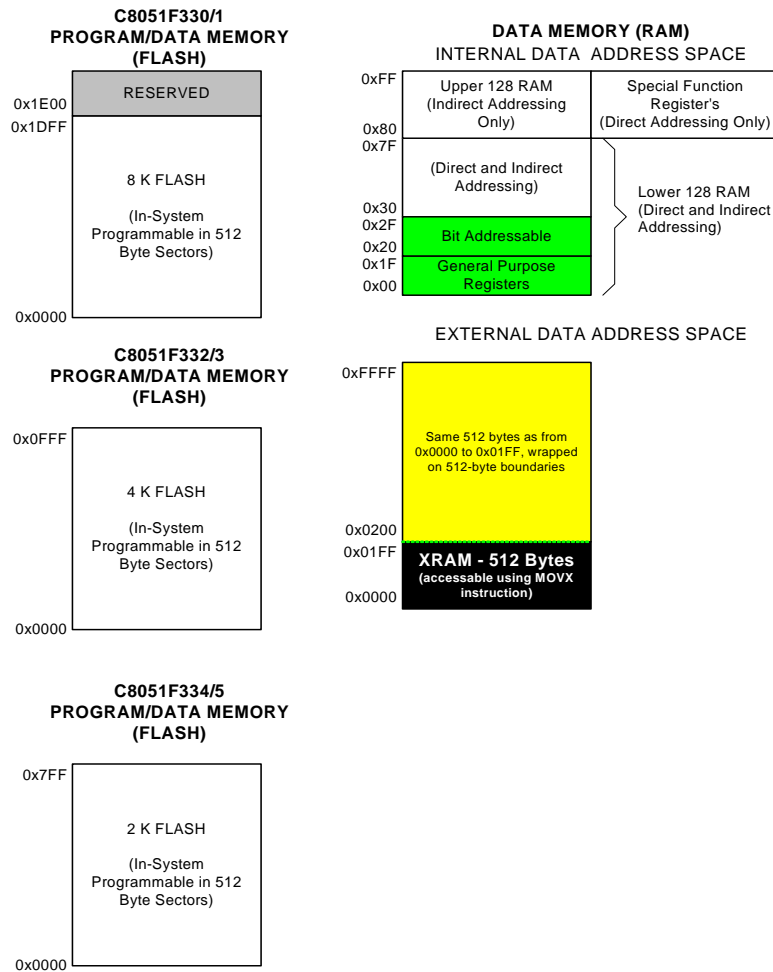

**Figure 9.2. Memory Map**

## 9.2.1. Program Memory

The CIP-51 core has a 64 kB program memory space. The C8051F330/1 implements 8 kB of this program memory space as in-system, re-programmable Flash memory, organized in a contiguous block from addresses 0x0000 to 0x1DFF. Addresses above 0x1DFF are reserved on the 8 kB devices. The C8051F332/3 and C8051F334/5 implement, in contiguous blocks, 2 and 4 kB, from addresses 0x0000 to 0x07FF or 0x0000 to 0x0FFF, respectively. Addresses above 0x0800 and 0x1000 are reserved on the 2 and 4 kB devices, respectively.

Program memory is normally assumed to be read-only. However, the CIP-51 can write to program memory by setting the Program Store Write Enable bit (PSCTL.0) and using the MOVX write instruction. This feature provides a mechanism for the CIP-51 to update program code and use the program memory space for non-volatile data storage. Refer to [Section “11. Flash Memory” on page 103](#) for further details.

# C8051F330/1/2/3/4/5

---

## 9.2.2. Data Memory

The CIP-51 includes 256 bytes of internal RAM mapped into the data memory space from 0x00 through 0xFF. The lower 128 bytes of data memory are used for general purpose registers and scratch pad memory. Either direct or indirect addressing may be used to access the lower 128 bytes of data memory. Locations 0x00 through 0x1F are addressable as four banks of general purpose registers, each bank consisting of eight byte-wide registers. The next 16 bytes, locations 0x20 through 0x2F, may either be addressed as bytes or as 128 bit locations accessible with the direct addressing mode.

The upper 128 bytes of data memory are accessible only by indirect addressing. This region occupies the same address space as the Special Function Registers (SFR) but is physically separate from the SFR space. The addressing mode used by an instruction when accessing locations above 0x7F determines whether the CPU accesses the upper 128 bytes of data memory space or the SFRs. Instructions that use direct addressing will access the SFR space. Instructions using indirect addressing above 0x7F access the upper 128 bytes of data memory. Figure 9.2 illustrates the data memory organization of the CIP-51.

## 9.2.3. General Purpose Registers

The lower 32 bytes of data memory, locations 0x00 through 0x1F, may be addressed as four banks of general-purpose registers. Each bank consists of eight byte-wide registers designated R0 through R7. Only one of these banks may be enabled at a time. Two bits in the program status word, RS0 (PSW.3) and RS1 (PSW.4), select the active register bank (see description of the PSW in SFR Definition 9.4). This allows fast context switching when entering subroutines and interrupt service routines. Indirect addressing modes use registers R0 and R1 as index registers.

## 9.2.4. Bit Addressable Locations

In addition to direct access to data memory organized as bytes, the sixteen data memory locations at 0x20 through 0x2F are also accessible as 128 individually addressable bits. Each bit has a bit address from 0x00 to 0x7F. Bit 0 of the byte at 0x20 has bit address 0x00 while bit7 of the byte at 0x20 has bit address 0x07. Bit 7 of the byte at 0x2F has bit address 0x7F. A bit access is distinguished from a full byte access by the type of instruction used (bit source or destination operands as opposed to a byte source or destination).

The MCS-51™ assembly language allows an alternate notation for bit addressing of the form XX.B where XX is the byte address and B is the bit position within the byte. For example, the instruction:

```
MOV    C, 22.3h
```

moves the Boolean value at 0x13 (bit 3 of the byte at location 0x22) into the Carry flag.

## 9.2.5. Stack

A programmer's stack can be located anywhere in the 256-byte data memory. The stack area is designated using the Stack Pointer (SP, 0x81) SFR. The SP will point to the last location used. The next value pushed on the stack is placed at SP+1 and then SP is incremented. A reset initializes the stack pointer to location 0x07. Therefore, the first value pushed on the stack is placed at location 0x08, which is also the first register (R0) of register bank 1. Thus, if more than one register bank is to be used, the SP should be initialized to a location in the data memory not being used for data storage. The stack depth can extend up to 256 bytes.

## 9.2.6. Special Function Registers

The direct-access data memory locations from 0x80 to 0xFF constitute the special function registers (SFRs). The SFRs provide control and data exchange with the CIP-51's resources and peripherals. The CIP-51 duplicates the SFRs found in a typical 8051 implementation as well as implementing additional SFRs used to configure and access the sub-systems unique to the MCU. This allows the addition of new functionality while retaining compatibility with the MCS-51™ instruction set. Table 9.2 lists the SFRs implemented in the CIP-51 System Controller.

The SFR registers are accessed anytime the direct addressing mode is used to access memory locations from 0x80 to 0xFF. SFRs with addresses ending in 0x0 or 0x8 (e.g. P0, TCON, SCON0, IE, etc.) are bit-addressable as well as byte-addressable. All other SFRs are byte-addressable only. Unoccupied addresses in the SFR space are reserved for future use. Accessing these areas will have an indeterminate effect and should be avoided. Refer to the corresponding pages of the data sheet, as indicated in Table 9.3, for a detailed description of each register.

**Table 9.2. Special Function Register (SFR) Memory Map**

F8	SPI0CN	PCA0L	PCA0H	PCA0CPL0	PCA0CPH0			VDM0CN
F0	B	P0MDIN	P1MDIN				EIP1	
E8	ADC0CN	PCA0CPL1	PCA0CPH1	PCA0CPL2	PCA0CPH2			RSTSRC
E0	ACC	XBR0	XBR1	OSCLCN	IT01CF		EIE1	
D8	PCA0CN	PCA0MD	PCA0CPM0	PCA0CPM1	PCA0CPM2			
D0	PSW	REF0CN			P0SKIP	P1SKIP		
C8	TMR2CN		TMR2RLL	TMR2RLH	TMR2L	TMR2H		
C0	SMB0CN	SMB0CF	SMB0DAT	ADC0GTL	ADC0GTH	ADC0LTL	ADC0LTH	
B8	IP	IDA0CN	AMX0N	AMX0P	ADC0CF	ADC0L	ADC0H	
B0		OSCXCN	OSCICN	OSCICL			FLSCL	FLKEY
A8	IE	CLKSEL	EMI0CN					
A0	P2	SPI0CFG	SPI0CKR	SPI0DAT	P0MDOUT	P1MDOUT	P2MDOUT	
98	SCON0	SBUF0		CPT0CN		CPT0MD		CPT0MX
90	P1	TMR3CN	TMR3RLL	TMR3RLH	TMR3L	TMR3H	IDA0L	IDA0H
88	TCON	TMOD	TL0	TL1	TH0	TH1	CKCON	PSCTL
80	P0	SP	DPL	DPH				PCON
	0(8)	1(9)	2(A)	3(B)	4(C)	5(D)	6(E)	7(F)

(bit addressable)

# C8051F330/1/2/3/4/5

**Table 9.3. Special Function Registers**

SFRs are listed in alphabetical order. All undefined SFR locations are reserved

Register	Address	Description	Page
<b>ACC</b>	0xE0	Accumulator	85
<b>ADC0CF</b>	0xBC	ADC0 Configuration	49
<b>ADC0CN</b>	0xE8	ADC0 Control	50
<b>ADC0GTH</b>	0xC4	ADC0 Greater-Than Compare High	51
<b>ADC0GTL</b>	0xC3	ADC0 Greater-Than Compare Low	51
<b>ADC0H</b>	0xBE	ADC0 High	49
<b>ADC0L</b>	0xBD	ADC0 Low	49
<b>ADC0LTH</b>	0xC6	ADC0 Less-Than Compare Word High	52
<b>ADC0LTL</b>	0xC5	ADC0 Less-Than Compare Word Low	52
<b>AMX0N</b>	0xBA	AMUX0 Negative Channel Select	48
<b>AMX0P</b>	0xBB	AMUX0 Positive Channel Select	47
<b>B</b>	0xF0	B Register	85
<b>CKCON</b>	0x8E	Clock Control	183
<b>CLKSEL</b>	0xA9	Clock Select	121
<b>CPT0CN</b>	0x9B	Comparator0 Control	67
<b>CPT0MD</b>	0x9D	Comparator0 Mode Selection	69
<b>CPT0MX</b>	0x9F	Comparator0 MUX Selection	68
<b>DPH</b>	0x83	Data Pointer High	83
<b>DPL</b>	0x82	Data Pointer Low	83
<b>EIE1</b>	0xE6	Extended Interrupt Enable 1	91
<b>EIP1</b>	0xF6	Extended Interrupt Priority 1	92
<b>EMIOCN</b>	0xAA	External Memory Interface Control	111
<b>FLKEY</b>	0xB7	Flash Lock and Key	109
<b>FLSCL</b>	0xB6	Flash Scale	109
<b>IDA0CN</b>	0xB9	Current Mode DAC0 Control	59
<b>IDA0H</b>	0x97	Current Mode DAC0 High	59
<b>IDA0L</b>	0x96	Current Mode DAC0 Low	60
<b>IE</b>	0xA8	Interrupt Enable	89
<b>IP</b>	0xB8	Interrupt Priority	90
<b>IT01CF</b>	0xE4	INT0/INT1 Configuration	93
<b>OSCICL</b>	0xB3	Internal Oscillator Calibration	114
<b>OSCICN</b>	0xB2	Internal Oscillator Control	114
<b>OSCLCN</b>	0xE3	Low-Frequency Oscillator Control	115



**Table 9.3. Special Function Registers (Continued)**

SFRs are listed in alphabetical order. All undefined SFR locations are reserved

Register	Address	Description	Page
<b>OSCXCN</b>	0xB1	External Oscillator Control	117
<b>P0</b>	0x80	Port 0 Latch	130
<b>P0MDIN</b>	0xF1	Port 0 Input Mode Configuration	130
<b>P0MDOUT</b>	0xA4	Port 0 Output Mode Configuration	131
<b>P0SKIP</b>	0xD4	Port 0 Skip	131
<b>P1</b>	0x90	Port 1 Latch	131
<b>P1MDIN</b>	0xF2	Port 1 Input Mode Configuration	132
<b>P1MDOUT</b>	0xA5	Port 1 Output Mode Configuration	132
<b>P1SKIP</b>	0xD5	Port 1 Skip	132
<b>P2</b>	0xA0	Port 2 Latch	133
<b>P2MDOUT</b>	0xA6	Port 2 Output Mode Configuration	133
<b>PCA0CN</b>	0xD8	PCA Control	205
<b>PCA0CPH0</b>	0xFC	PCA Capture 0 High	208
<b>PCA0CPH1</b>	0xEA	PCA Capture 1 High	208
<b>PCA0CPH2</b>	0xEC	PCA Capture 2 High	208
<b>PCA0CPL0</b>	0xFB	PCA Capture 0 Low	208
<b>PCA0CPL1</b>	0xE9	PCA Capture 1 Low	208
<b>PCA0CPL2</b>	0xEB	PCA Capture 2 Low	208
<b>PCA0CPM0</b>	0xDA	PCA Module 0 Mode Register	207
<b>PCA0CPM1</b>	0xDB	PCA Module 1 Mode Register	207
<b>PCA0CPM2</b>	0xDC	PCA Module 2 Mode Register	207
<b>PCA0H</b>	0xFA	PCA Counter High	208
<b>PCA0L</b>	0xF9	PCA Counter Low	208
<b>PCA0MD</b>	0xD9	PCA Mode	206
<b>PCON</b>	0x87	Power Control	95
<b>PSCTL</b>	0x8F	Program Store R/W Control	108
<b>PSW</b>	0xD0	Program Status Word	84
<b>REF0CN</b>	0xD1	Voltage Reference Control	62
<b>RSTSRC</b>	0xEF	Reset Source Configuration/Status	101
<b>SBUF0</b>	0x99	UART0 Data Buffer	159
<b>SCON0</b>	0x98	UART0 Control	158
<b>SMB0CF</b>	0xC1	SMBus Configuration	142
<b>SMB0CN</b>	0xC0	SMBus Control	144
<b>SMB0DAT</b>	0xC2	SMBus Data	146

# C8051F330/1/2/3/4/5

**Table 9.3. Special Function Registers (Continued)**

SFRs are listed in alphabetical order. All undefined SFR locations are reserved

Register	Address	Description	Page
<b>SP</b>	0x81	Stack Pointer	83
<b>SPI0CFG</b>	0xA1	SPI Configuration	170
<b>SPI0CKR</b>	0xA2	SPI Clock Rate Control	172
<b>SPI0CN</b>	0xF8	SPI Control	171
<b>SPI0DAT</b>	0xA3	SPI Data	172
<b>TCON</b>	0x88	Timer/Counter Control	181
<b>TH0</b>	0x8C	Timer/Counter 0 High	184
<b>TH1</b>	0x8D	Timer/Counter 1 High	184
<b>TL0</b>	0x8A	Timer/Counter 0 Low	184
<b>TL1</b>	0x8B	Timer/Counter 1 Low	184
<b>TMOD</b>	0x89	Timer/Counter Mode	182
<b>TMR2CN</b>	0xC8	Timer/Counter 2 Control	187
<b>TMR2H</b>	0xCD	Timer/Counter 2 High	188
<b>TMR2L</b>	0xCC	Timer/Counter 2 Low	188
<b>TMR2RLH</b>	0xCB	Timer/Counter 2 Reload High	188
<b>TMR2RLL</b>	0xCA	Timer/Counter 2 Reload Low	188
<b>TMR3CN</b>	0x91	Timer/Counter 3Control	191
<b>TMR3H</b>	0x95	Timer/Counter 3 High	192
<b>TMR3L</b>	0x94	Timer/Counter 3Low	192
<b>TMR3RLH</b>	0x93	Timer/Counter 3 Reload High	192
<b>TMR3RLL</b>	0x92	Timer/Counter 3 Reload Low	192
<b>VDM0CN</b>	0xFF	V <sub>DD</sub> Monitor Control	99
<b>XBR0</b>	0xE1	Port I/O Crossbar Control 0	128
<b>XBR1</b>	0xE2	Port I/O Crossbar Control 1	129

## 9.2.7. Register Descriptions

Following are descriptions of SFRs related to the operation of the CIP-51 System Controller. Reserved bits should not be set to logic 1. Future product versions may use these bits to implement new features in which case the reset value of the bit will be logic 0, selecting the feature's default state. Detailed descriptions of the remaining SFRs are included in the sections of the datasheet associated with their corresponding system function.

### SFR Definition 9.1. DPL: Data Pointer Low Byte

R/W	R/W	R/W	R/W	R/W	R/W	R/W	R/W	Reset Value
								00000000
Bit7	Bit6	Bit5	Bit4	Bit3	Bit2	Bit1	Bit0	SFR Address: 0x82

Bits7–0: DPL: Data Pointer Low.  
The DPL register is the low byte of the 16-bit DPTR. DPTR is used to access indirectly addressed Flash memory or XRAM.

### SFR Definition 9.2. DPH: Data Pointer High Byte

R/W	R/W	R/W	R/W	R/W	R/W	R/W	R/W	Reset Value
								00000000
Bit7	Bit6	Bit5	Bit4	Bit3	Bit2	Bit1	Bit0	SFR Address: 0x83

Bits7–0: DPH: Data Pointer High.  
The DPH register is the high byte of the 16-bit DPTR. DPTR is used to access indirectly addressed Flash memory or XRAM.

### SFR Definition 9.3. SP: Stack Pointer

R/W	R/W	R/W	R/W	R/W	R/W	R/W	R/W	Reset Value
								00000111
Bit7	Bit6	Bit5	Bit4	Bit3	Bit2	Bit1	Bit0	SFR Address: 0x81

Bits7–0: SP: Stack Pointer.  
The Stack Pointer holds the location of the top of the stack. The stack pointer is incremented before every PUSH operation. The SP register defaults to 0x07 after reset.

# C8051F330/1/2/3/4/5

## SFR Definition 9.4. PSW: Program Status Word

R/W	R/W	R/W	R/W	R/W	R/W	R/W	R	Reset Value
CY	AC	F0	RS1	RS0	OV	F1	PARITY	00000000
Bit7	Bit6	Bit5	Bit4	Bit3	Bit2	Bit1	Bit0	SFR Address: 0xD0
						(bit addressable)		

- Bit7:** CY: Carry Flag.  
This bit is set when the last arithmetic operation resulted in a carry (addition) or a borrow (subtraction). It is cleared to logic 0 by all other arithmetic operations.
- Bit6:** AC: Auxiliary Carry Flag  
This bit is set when the last arithmetic operation resulted in a carry into (addition) or a borrow from (subtraction) the high order nibble. It is cleared to logic 0 by all other arithmetic operations.
- Bit5:** F0: User Flag 0.  
This is a bit-addressable, general purpose flag for use under software control.
- Bits4–3:** RS1–RS0: Register Bank Select.  
These bits select which register bank is used during register accesses.

RS1	RS0	Register Bank	Address
0	0	0	0x00–0x07
0	1	1	0x08–0x0F
1	0	2	0x10–0x17
1	1	3	0x18–0x1F

- Bit2:** OV: Overflow Flag.  
This bit is set to 1 under the following circumstances:
- An ADD, ADDC, or SUBB instruction causes a sign-change overflow.
  - A MUL instruction results in an overflow (result is greater than 255).
  - A DIV instruction causes a divide-by-zero condition.
- The OV bit is cleared to 0 by the ADD, ADDC, SUBB, MUL, and DIV instructions in all other cases.
- Bit1:** F1: User Flag 1.  
This is a bit-addressable, general purpose flag for use under software control.
- Bit0:** PARITY: Parity Flag.  
This bit is set to logic 1 if the sum of the eight bits in the accumulator is odd and cleared if the sum is even.

## SFR Definition 9.5. ACC: Accumulator

R/W	R/W	R/W	R/W	R/W	R/W	R/W	R/W	Reset Value
ACC.7	ACC.6	ACC.5	ACC.4	ACC.3	ACC.2	ACC.1	ACC.0	00000000
Bit7	Bit6	Bit5	Bit4	Bit3	Bit2	Bit1	Bit0	SFR Address: (bit addressable) 0xE0

Bits7–0: ACC: Accumulator.  
This register is the accumulator for arithmetic operations.

## SFR Definition 9.6. B: B Register

R/W	R/W	R/W	R/W	R/W	R/W	R/W	R/W	Reset Value
B.7	B.6	B.5	B.4	B.3	B.2	B.1	B.0	00000000
Bit7	Bit6	Bit5	Bit4	Bit3	Bit2	Bit1	Bit0	SFR Address: (bit addressable) 0xF0

Bits7–0: B: B Register.  
This register serves as a second accumulator for certain arithmetic operations.

### 9.3. Interrupt Handler

The CIP-51 includes an extended interrupt system supporting a total of 13 interrupt sources with two priority levels. The allocation of interrupt sources between on-chip peripherals and external inputs pins varies according to the specific version of the device. Each interrupt source has one or more associated interrupt-pending flag(s) located in an SFR. When a peripheral or external source meets a valid interrupt condition, the associated interrupt-pending flag is set to logic 1.

If interrupts are enabled for the source, an interrupt request is generated when the interrupt-pending flag is set. As soon as execution of the current instruction is complete, the CPU generates an LCALL to a predetermined address to begin execution of an interrupt service routine (ISR). Each ISR must end with an RETI instruction, which returns program execution to the next instruction that would have been executed if the interrupt request had not occurred. If interrupts are not enabled, the interrupt-pending flag is ignored by the hardware and program execution continues as normal. (The interrupt-pending flag is set to logic 1 regardless of the interrupt's enable/disable state.)

Each interrupt source can be individually enabled or disabled through the use of an associated interrupt enable bit in an SFR (IE–EIE1). However, interrupts must first be globally enabled by setting the EA bit (IE.7) to logic 1 before the individual interrupt enables are recognized. Setting the EA bit to logic 0 disables all interrupt sources regardless of the individual interrupt-enable settings.

**Note:** Any instruction that clears the EA bit should be immediately followed by an instruction that has two or more opcode bytes. For example:

```
// in 'C':
EA = 0; // clear EA bit.
```

# C8051F330/1/2/3/4/5

---

```
EA = 0; // this is a dummy instruction with two-byte opcode.
```

```
; in assembly:
```

```
CLR EA ; clear EA bit.
```

```
CLR EA ; this is a dummy instruction with two-byte opcode.
```

If an interrupt is posted during the execution phase of a "CLR EA" opcode (or any instruction which clears the EA bit), and the instruction is followed by a single-cycle instruction, the interrupt may be taken. However, a read of the EA bit will return a '0' inside the interrupt service routine. When the "CLR EA" opcode is followed by a multi-cycle instruction, the interrupt will not be taken.

Some interrupt-pending flags are automatically cleared by the hardware when the CPU vectors to the ISR. However, most are not cleared by the hardware and must be cleared by software before returning from the ISR. If an interrupt-pending flag remains set after the CPU completes the return-from-interrupt (RETI) instruction, a new interrupt request will be generated immediately and the CPU will re-enter the ISR after the completion of the next instruction.

## 9.3.1. MCU Interrupt Sources and Vectors

The MCUs support 13 interrupt sources. Software can simulate an interrupt by setting any interrupt-pending flag to logic 1. If interrupts are enabled for the flag, an interrupt request will be generated and the CPU will vector to the ISR address associated with the interrupt-pending flag. MCU interrupt sources, associated vector addresses, priority order and control bits are summarized in Table 9.4 on page 88. Refer to the datasheet section associated with a particular on-chip peripheral for information regarding valid interrupt conditions for the peripheral and the behavior of its interrupt-pending flag(s).

## 9.3.2. External Interrupts

The /INT0 and /INT1 external interrupt sources are configurable as active high or low, edge or level sensitive. The IN0PL (/INT0 Polarity) and IN1PL (/INT1 Polarity) bits in the IT01CF register select active high or active low; the IT0 and IT1 bits in TCON ([Section “18.1. Timer 0 and Timer 1” on page 177](#)) select level or edge sensitive. The table below lists the possible configurations.

IT0	IN0PL	/INT0 Interrupt
1	0	Active low, edge sensitive
1	1	Active high, edge sensitive
0	0	Active low, level sensitive
0	1	Active high, level sensitive

IT1	IN1PL	/INT1 Interrupt
1	0	Active low, edge sensitive
1	1	Active high, edge sensitive
0	0	Active low, level sensitive
0	1	Active high, level sensitive

/INT0 and /INT1 are assigned to Port pins as defined in the IT01CF register (see SFR Definition 9.11). Note that /INT0 and /INT1 Port pin assignments are independent of any Crossbar assignments. /INT0 and /INT1 will monitor their assigned Port pins without disturbing the peripheral that was assigned the Port pin via the Crossbar. To assign a Port pin only to /INT0 and/or /INT1, configure the Crossbar to skip the selected pin(s). This is accomplished by setting the associated bit in register XBR0 (see [Section “14.1. Priority Crossbar Decoder” on page 125](#) for complete details on configuring the Crossbar).

IE0 (TCON.1) and IE1 (TCON.3) serve as the interrupt-pending flags for the /INT0 and /INT1 external interrupts, respectively. If an /INT0 or /INT1 external interrupt is configured as edge-sensitive, the corresponding interrupt-pending flag is automatically cleared by the hardware when the CPU vectors to the ISR. When configured as level sensitive, the interrupt-pending flag remains logic 1 while the input is active as defined by the corresponding polarity bit (IN0PL or IN1PL); the flag remains logic 0 while the input is inactive. The external interrupt source must hold the input active until the interrupt request is recognized. It must then deactivate the interrupt request before execution of the ISR completes or another interrupt request will be generated.

## 9.3.3. Interrupt Priorities

Each interrupt source can be individually programmed to one of two priority levels: low or high. A low priority interrupt service routine can be preempted by a high priority interrupt. A high priority interrupt cannot be preempted. Each interrupt has an associated interrupt priority bit in an SFR (IP or EIP1) used to configure its priority level. Low priority is the default. If two interrupts are recognized simultaneously, the interrupt with the higher priority is serviced first. If both interrupts have the same priority level, a fixed priority order is used to arbitrate, given in Table 9.4.

## 9.3.4. Interrupt Latency

Interrupt response time depends on the state of the CPU when the interrupt occurs. Pending interrupts are sampled and priority decoded each system clock cycle. Therefore, the fastest possible response time is 5 system clock cycles: 1 clock cycle to detect the interrupt and 4 clock cycles to complete the LCALL to the ISR. If an interrupt is pending when a RETI is executed, a single instruction is executed before an LCALL is made to service the pending interrupt. Therefore, the maximum response time for an interrupt (when no other interrupt is currently being serviced or the new interrupt is of greater priority) occurs when the CPU is performing an RETI instruction followed by a DIV as the next instruction. In this case, the response time is 18 system clock cycles: 1 clock cycle to detect the interrupt, 5 clock cycles to execute the RETI, 8 clock cycles to complete the DIV instruction and 4 clock cycles to execute the LCALL to the ISR. If the CPU is executing an ISR for an interrupt with equal or higher priority, the new interrupt will not be serviced until the current ISR completes, including the RETI and following instruction.

**Table 9.4. Interrupt Summary**

Interrupt Source	Interrupt Vector	Priority Order	Pending Flag	Bit addressable?	Cleared by HW?	Enable Flag	Priority Control
Reset	0x0000	Top	None	N/A	N/A	Always Enabled	Always Highest
External Interrupt 0 (/INT0)	0x0003	0	IE0 (TCON.1)	Y	Y	EX0 (IE.0)	PX0 (IP.0)
Timer 0 Overflow	0x000B	1	TF0 (TCON.5)	Y	Y	ET0 (IE.1)	PT0 (IP.1)
External Interrupt 1 (/INT1)	0x0013	2	IE1 (TCON.3)	Y	Y	EX1 (IE.2)	PX1 (IP.2)
Timer 1 Overflow	0x001B	3	TF1 (TCON.7)	Y	Y	ET1 (IE.3)	PT1 (IP.3)
UART0	0x0023	4	RI0 (SCON0.0) TI0 (SCON0.1)	Y	N	ES0 (IE.4)	PS0 (IP.4)
Timer 2 Overflow	0x002B	5	TF2H (TMR2CN.7) TF2L (TMR2CN.6)	Y	N	ET2 (IE.5)	PT2 (IP.5)
SPI0	0x0033	6	SPIF (SPI0CN.7) WCOL (SPI0CN.6) MODF (SPI0CN.5) RXOVRN (SPI0CN.4)	Y	N	ESPI0 (IE.6)	PSPI0 (IP.6)
SMB0	0x003B	7	SI (SMB0CN.0)	Y	N	ESMB0 (EIE1.0)	PSMB0 (EIP1.0)
RESERVED	0x0043	8	N/A	N/A	N/A	N/A	N/A
ADC0 Window Compare	0x004B	9	AD0WINT (ADC0CN.3)	Y	N	EWADC0 (EIE1.2)	PWADC0 (EIP1.2)
ADC0 Conversion Complete	0x0053	10	AD0INT (ADC0CN.5)	Y	N	EADC0 (EIE1.3)	PADC0 (EIP1.3)
Programmable Counter Array	0x005B	11	CF (PCA0CN.7) CCFn (PCA0CN.n)	Y	N	EPCA0 (EIE1.4)	PPCA0 (EIP1.4)
Comparator0	0x0063	12	CP0FIF (CPT0CN.4) CP0RIF (CPT0CN.5)	N	N	ECP0 (EIE1.5)	PCP0 (EIP1.5)
RESERVED	0x006B	13	N/A	N/A	N/A	N/A	N/A
Timer 3 Overflow	0x0073	14	TF3H (TMR3CN.7) TF3L (TMR3CN.6)	N	N	ET3 (EIE1.7)	PT3 (EIP1.7)



## 9.3.5. Interrupt Register Descriptions

The SFRs used to enable the interrupt sources and set their priority level are described below. Refer to the data sheet section associated with a particular on-chip peripheral for information regarding valid interrupt conditions for the peripheral and the behavior of its interrupt-pending flag(s).

### SFR Definition 9.7. IE: Interrupt Enable

R/W	R/W	R/W	R/W	R/W	R/W	R/W	R/W	Reset Value
EA	ESPI0	ET2	ES0	ET1	EX1	ET0	EX0	00000000
Bit7	Bit6	Bit5	Bit4	Bit3	Bit2	Bit1	Bit0	SFR Address: 0xA8
						(bit addressable)		
Bit7:	EA: Enable All Interrupts. This bit globally enables/disables all interrupts. It overrides the individual interrupt mask settings. 0: Disable all interrupt sources. 1: Enable each interrupt according to its individual mask setting.							
Bit6:	ESPI0: Enable Serial Peripheral Interface (SPI0) Interrupt. This bit sets the masking of the SPI0 interrupts. 0: Disable all SPI0 interrupts. 1: Enable interrupt requests generated by SPI0.							
Bit5:	ET2: Enable Timer 2 Interrupt. This bit sets the masking of the Timer 2 interrupt. 0: Disable Timer 2 interrupt. 1: Enable interrupt requests generated by the TF2L or TF2H flags.							
Bit4:	ES0: Enable UART0 Interrupt. This bit sets the masking of the UART0 interrupt. 0: Disable UART0 interrupt. 1: Enable UART0 interrupt.							
Bit3:	ET1: Enable Timer 1 Interrupt. This bit sets the masking of the Timer 1 interrupt. 0: Disable all Timer 1 interrupt. 1: Enable interrupt requests generated by the TF1 flag.							
Bit2:	EX1: Enable External Interrupt 1. This bit sets the masking of External Interrupt 1. 0: Disable external interrupt 1. 1: Enable interrupt requests generated by the /INT1 input.							
Bit1:	ET0: Enable Timer 0 Interrupt. This bit sets the masking of the Timer 0 interrupt. 0: Disable all Timer 0 interrupt. 1: Enable interrupt requests generated by the TF0 flag.							
Bit0:	EX0: Enable External Interrupt 0. This bit sets the masking of External Interrupt 0. 0: Disable external interrupt 0. 1: Enable interrupt requests generated by the /INT0 input.							

# C8051F330/1/2/3/4/5

## SFR Definition 9.8. IP: Interrupt Priority

R	R/W	R/W	R/W	R/W	R/W	R/W	R/W	Reset Value
-	PSPI0	PT2	PS0	PT1	PX1	PT0	PX0	10000000
Bit7	Bit6	Bit5	Bit4	Bit3	Bit2	Bit1	Bit0	SFR Address: 0xB8
						(bit addressable)		

Bit7: UNUSED. Read = 1, Write = don't care.  
 Bit6: PSPI0: Serial Peripheral Interface (SPI0) Interrupt Priority Control.  
 This bit sets the priority of the SPI0 interrupt.  
 0: SPI0 interrupt set to low priority level.  
 1: SPI0 interrupt set to high priority level.  
 Bit5: PT2: Timer 2 Interrupt Priority Control.  
 This bit sets the priority of the Timer 2 interrupt.  
 0: Timer 2 interrupt set to low priority level.  
 1: Timer 2 interrupt set to high priority level.  
 Bit4: PS0: UART0 Interrupt Priority Control.  
 This bit sets the priority of the UART0 interrupt.  
 0: UART0 interrupt set to low priority level.  
 1: UART0 interrupt set to high priority level.  
 Bit3: PT1: Timer 1 Interrupt Priority Control.  
 This bit sets the priority of the Timer 1 interrupt.  
 0: Timer 1 interrupt set to low priority level.  
 1: Timer 1 interrupt set to high priority level.  
 Bit2: PX1: External Interrupt 1 Priority Control.  
 This bit sets the priority of the External Interrupt 1 interrupt.  
 0: External Interrupt 1 set to low priority level.  
 1: External Interrupt 1 set to high priority level.  
 Bit1: PT0: Timer 0 Interrupt Priority Control.  
 This bit sets the priority of the Timer 0 interrupt.  
 0: Timer 0 interrupt set to low priority level.  
 1: Timer 0 interrupt set to high priority level.  
 Bit0: PX0: External Interrupt 0 Priority Control.  
 This bit sets the priority of the External Interrupt 0 interrupt.  
 0: External Interrupt 0 set to low priority level.  
 1: External Interrupt 0 set to high priority level.

## SFR Definition 9.9. EIE1: Extended Interrupt Enable 1

R/W	R/W	R/W	R/W	R/W	R/W	R/W	R/W	Reset Value
ET3	Reserved	ECP0	EPCA0	EADC0	EWADC0	Reserved	ESMB0	00000000
Bit7	Bit6	Bit5	Bit4	Bit3	Bit2	Bit1	Bit0	SFR Address: 0xE6

**Bit7:** ET3: Enable Timer 3 Interrupt.  
 This bit sets the masking of the Timer 3 interrupt.  
 0: Disable Timer 3 interrupts.  
 1: Enable interrupt requests generated by the TF3L or TF3H flags.

**Bit6:** RESERVED. Read = 0. Must Write 0.

**Bit5:** ECP0: Enable Comparator0 (CP0) Interrupt.  
 This bit sets the masking of the CP0 interrupt.  
 0: Disable CP0 interrupts.  
 1: Enable interrupt requests generated by the CP0RIF or CP0FIF flags.

**Bit4:** EPCA0: Enable Programmable Counter Array (PCA0) Interrupt.  
 This bit sets the masking of the PCA0 interrupts.  
 0: Disable all PCA0 interrupts.  
 1: Enable interrupt requests generated by PCA0.

**Bit3:** EADC0: Enable ADC0 Conversion Complete Interrupt.  
 This bit sets the masking of the ADC0 Conversion Complete interrupt.  
 0: Disable ADC0 Conversion Complete interrupt.  
 1: Enable interrupt requests generated by the AD0INT flag.

**Bit2:** EWADC0: Enable Window Comparison ADC0 Interrupt.  
 This bit sets the masking of ADC0 Window Comparison interrupt.  
 0: Disable ADC0 Window Comparison interrupt.  
 1: Enable interrupt requests generated by ADC0 Window Compare flag (AD0WINT).

**Bit1:** RESERVED. Read = 0. Must Write 0.

**Bit0:** ESMB0: Enable SMBus (SMB0) Interrupt.  
 This bit sets the masking of the SMB0 interrupt.  
 0: Disable all SMB0 interrupts.  
 1: Enable interrupt requests generated by SMB0.

# C8051F330/1/2/3/4/5

## SFR Definition 9.10. EIP1: Extended Interrupt Priority 1

R/W	R/W	R/W	R/W	R/W	R/W	R/W	R/W	Reset Value
PT3	Reserved	PCP0	PPCA0	PADC0	PWADC0	Reserved	PSMB0	00000000
Bit7	Bit6	Bit5	Bit4	Bit3	Bit2	Bit1	Bit0	SFR Address: 0xF6
Bit7:	PT3: Timer 3 Interrupt Priority Control. This bit sets the priority of the Timer 3 interrupt. 0: Timer 3 interrupts set to low priority level. 1: Timer 3 interrupts set to high priority level.							
Bit6:	RESERVED. Read = 0. Must Write 0.							
Bit5:	PCP0: Comparator0 (CP0) Interrupt Priority Control. This bit sets the priority of the CP0 interrupt. 0: CP0 interrupt set to low priority level. 1: CP0 interrupt set to high priority level.							
Bit4:	PPCA0: Programmable Counter Array (PCA0) Interrupt Priority Control. This bit sets the priority of the PCA0 interrupt. 0: PCA0 interrupt set to low priority level. 1: PCA0 interrupt set to high priority level.							
Bit3:	PADC0 ADC0 Conversion Complete Interrupt Priority Control. This bit sets the priority of the ADC0 Conversion Complete interrupt. 0: ADC0 Conversion Complete interrupt set to low priority level. 1: ADC0 Conversion Complete interrupt set to high priority level.							
Bit2:	PWADC0: ADC0 Window Comparator Interrupt Priority Control. This bit sets the priority of the ADC0 Window interrupt. 0: ADC0 Window interrupt set to low priority level. 1: ADC0 Window interrupt set to high priority level.							
Bit1:	RESERVED. Read = 0. Must Write 0.							
Bit0:	PSMB0: SMBus (SMB0) Interrupt Priority Control. This bit sets the priority of the SMB0 interrupt. 0: SMB0 interrupt set to low priority level. 1: SMB0 interrupt set to high priority level.							

## SFR Definition 9.11. IT01CF: INT0/INT1 Configuration

R/W	R/W	R/W	R/W	R/W	R/W	R/W	R/W	Reset Value
IN1PL	IN1SL2	IN1SL1	IN1SL0	IN0PL	IN0SL2	IN0SL1	IN0SL0	0000001
Bit7	Bit6	Bit5	Bit4	Bit3	Bit2	Bit1	Bit0	SFR Address: 0xE4

**\*Note:** Refer to SFR Definition 18.1 for INT0/1 edge- or level-sensitive interrupt selection.

Bit7: IN1PL: /INT1 Polarity  
 0: /INT1 input is active low.  
 1: /INT1 input is active high.

Bits6–4: IN1SL2–0: /INT1 Port Pin Selection Bits  
 These bits select which Port pin is assigned to /INT1. Note that this pin assignment is independent of the Crossbar; /INT1 will monitor the assigned Port pin without disturbing the peripheral that has been assigned the Port pin via the Crossbar. The Crossbar will not assign the Port pin to a peripheral if it is configured to skip the selected pin (accomplished by setting to ‘1’ the corresponding bit in register P0SKIP).

IN1SL2–0	/INT1 Port Pin
000	P0.0
001	P0.1
010	P0.2
011	P0.3
100	P0.4
101	P0.5
110	P0.6
111	P0.7

Bit3: IN0PL: /INT0 Polarity  
 0: /INT0 interrupt is active low.  
 1: /INT0 interrupt is active high.

Bits2–0: INT0SL2–0: /INT0 Port Pin Selection Bits  
 These bits select which Port pin is assigned to /INT0. Note that this pin assignment is independent of the Crossbar. /INT0 will monitor the assigned Port pin without disturbing the peripheral that has been assigned the Port pin via the Crossbar. The Crossbar will not assign the Port pin to a peripheral if it is configured to skip the selected pin (accomplished by setting to ‘1’ the corresponding bit in register P0SKIP).

IN0SL2–0	/INT0 Port Pin
000	P0.0
001	P0.1
010	P0.2
011	P0.3
100	P0.4
101	P0.5
110	P0.6
111	P0.7

# C8051F330/1/2/3/4/5

## 9.4. Power Management Modes

The CIP-51 core has two software programmable power management modes: Idle and Stop. Idle mode halts the CPU while leaving the peripherals and clocks active. In Stop mode, the CPU is halted, all interrupts and timers (except the Missing Clock Detector) are inactive, and the internal oscillator is stopped (analog peripherals remain in their selected states; the external oscillator is not effected). Since clocks are running in Idle mode, power consumption is dependent upon the system clock frequency and the number of peripherals left in active mode before entering Idle. Stop mode consumes the least power. SFR Definition 9.12 describes the Power Control Register (PCON) used to control the CIP-51's power management modes.

Although the CIP-51 has Idle and Stop modes built in (as with any standard 8051 architecture), power management of the entire MCU is better accomplished by enabling/disabling individual peripherals as needed. Each analog peripheral can be disabled when not in use and placed in low power mode. Digital peripherals, such as timers or serial buses, draw little power when they are not in use. Turning off the oscillators lowers power consumption considerably; however a reset is required to restart the MCU.

### 9.4.1. Idle Mode

Setting the Idle Mode Select bit (PCON.0) causes the CIP-51 to halt the CPU and enter Idle mode as soon as the instruction that sets the bit completes execution. All internal registers and memory maintain their original data. All analog and digital peripherals can remain active during Idle mode.

Idle mode is terminated when an enabled interrupt is asserted or a reset occurs. The assertion of an enabled interrupt will cause the Idle Mode Selection bit (PCON.0) to be cleared and the CPU to resume operation. The pending interrupt will be serviced and the next instruction to be executed after the return from interrupt (RETI) will be the instruction immediately following the one that set the Idle Mode Select bit. If Idle mode is terminated by an internal or external reset, the CIP-51 performs a normal reset sequence and begins program execution at address 0x0000.

Note: If the instruction following the write of the IDLE bit is a single-byte instruction and an interrupt occurs during the execution phase of the instruction that sets the IDLE bit, the CPU may not wake from Idle mode when a future interrupt occurs. Therefore, instructions that set the IDLE bit should be followed by an instruction that has two or more opcode bytes, for example:

```
// in 'C':
PCON |= 0x01;           // set IDLE bit
PCON = PCON;           // ... followed by a 3-cycle dummy instruction

; in assembly:
ORL PCON, #01h         ; set IDLE bit
MOV PCON, PCON         ; ... followed by a 3-cycle dummy instruction
```

If enabled, the Watchdog Timer (WDT) will eventually cause an internal watchdog reset and thereby terminate the Idle mode. This feature protects the system from an unintended permanent shutdown in the event of an inadvertent write to the PCON register. If this behavior is not desired, the WDT may be disabled by software prior to entering the Idle mode if the WDT was initially configured to allow this operation. This provides the opportunity for additional power savings, allowing the system to remain in the Idle mode indefinitely, waiting for an external stimulus to wake up the system. Refer to [Section "10.6. PCA Watchdog Timer Reset" on page 100](#) for more information on the use and configuration of the WDT.

## 9.4.2. Stop Mode

Setting the Stop Mode Select bit (PCON.1) causes the CIP-51 to enter Stop mode as soon as the instruction that sets the bit completes execution. In Stop mode the internal oscillator, CPU, and all digital peripherals are stopped; the state of the external oscillator circuit is not affected. Each analog peripheral (including the external oscillator circuit) may be shut down individually prior to entering Stop Mode. Stop mode can only be terminated by an internal or external reset. On reset, the CIP-51 performs the normal reset sequence and begins program execution at address 0x0000.

If enabled, the Missing Clock Detector will cause an internal reset and thereby terminate the Stop mode. The Missing Clock Detector should be disabled if the CPU is to be put in STOP mode for longer than the MCD timeout of 100  $\mu$ s.

### SFR Definition 9.12. PCON: Power Control

R/W	R/W	R/W	R/W	R/W	R/W	R/W	R/W	Reset Value
GF5	GF4	GF3	GF2	GF1	GF0	STOP	IDLE	00000000
Bit7	Bit6	Bit5	Bit4	Bit3	Bit2	Bit1	Bit0	SFR Address: 0x87

Bits7–2: GF5–GF0: General Purpose Flags 5–0.  
These are general purpose flags for use under software control.

Bit1: STOP: Stop Mode Select.  
Setting this bit will place the CIP-51 in Stop mode. This bit will always be read as 0.  
1: CPU goes into Stop mode (internal oscillator stopped).

Bit0: IDLE: Idle Mode Select.  
Setting this bit will place the CIP-51 in Idle mode. This bit will always be read as 0.  
1: CPU goes into Idle mode. (Shuts off clock to CPU, but clock to Timers, Interrupts, Serial Ports, and Analog Peripherals are still active.)

# C8051F330/1/2/3/4/5

---



## 10. Reset Sources

Reset circuitry allows the controller to be easily placed in a predefined default condition. On entry to this reset state, the following occur:

- CIP-51 halts program execution
- Special Function Registers (SFRs) are initialized to their defined reset values
- External Port pins are forced to a known state
- Interrupts and timers are disabled.

All SFRs are reset to the predefined values noted in the SFR detailed descriptions. The contents of internal data memory are unaffected during a reset; any previously stored data is preserved. However, since the stack pointer SFR is reset, the stack is effectively lost, even though the data on the stack is not altered.

The Port I/O latches are reset to 0xFF (all logic ones) in open-drain mode. Weak pullups are enabled during and after the reset. For VDD Monitor and power-on resets, the RST pin is driven low until the device exits the reset state.

On exit from the reset state, the program counter (PC) is reset, and the system clock defaults to the internal oscillator. Refer to [Section “13. Oscillators” on page 113](#) for information on selecting and configuring the system clock source. The Watchdog Timer is enabled with the system clock divided by 12 as its clock source ([Section “19.3. Watchdog Timer Mode” on page 201](#) details the use of the Watchdog Timer). Program execution begins at location 0x0000.

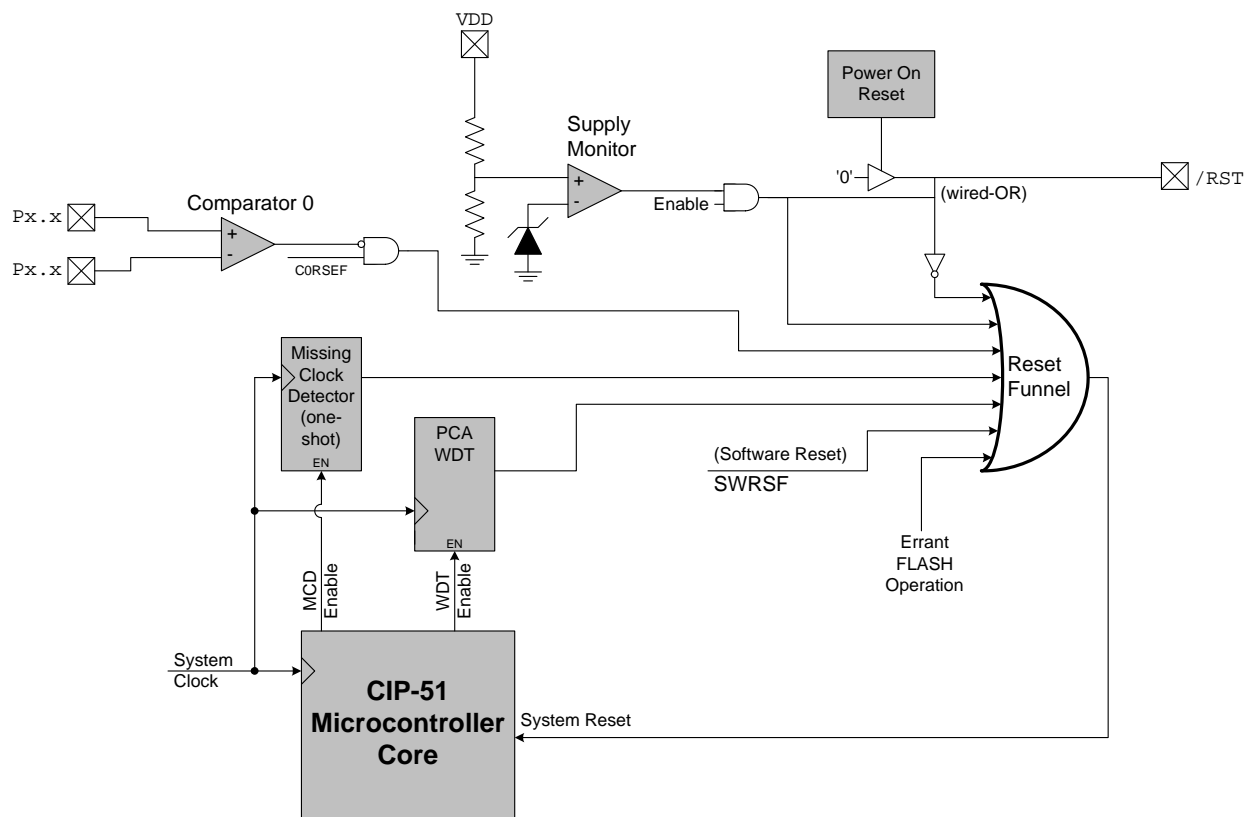

Figure 10.1. Reset Sources

# C8051F330/1/2/3/4/5

## 10.1. Power-On Reset

During power-up, the device is held in a reset state and the  $\overline{\text{RST}}$  pin is driven low until  $V_{\text{DD}}$  settles above  $V_{\text{RST}}$ . A delay occurs before the device is released from reset; the delay decreases as the  $V_{\text{DD}}$  ramp time increases ( $V_{\text{DD}}$  ramp time is defined as how fast  $V_{\text{DD}}$  ramps from 0 V to  $V_{\text{RST}}$ ). Figure 10.2. plots the power-on and  $V_{\text{DD}}$  monitor reset timing. The maximum  $V_{\text{DD}}$  ramp time is 1 ms; slower ramp times may cause the device to be released from reset before  $V_{\text{DD}}$  reaches the  $V_{\text{RST}}$  level. For ramp times less than 1 ms, the power-on reset delay ( $T_{\text{PORDelay}}$ ) is typically less than 0.3 ms.

On exit from a power-on reset, the PORSF flag (RSTSRC.1) is set by hardware to logic 1. When PORSF is set, all of the other reset flags in the RSTSRC Register are indeterminate (PORSF is cleared by all other resets). Since all resets cause program execution to begin at the same location (0x0000) software can read the PORSF flag to determine if a power-up was the cause of reset. The content of internal data memory should be assumed to be undefined after a power-on reset. The  $V_{\text{DD}}$  monitor is disabled following a power-on reset.

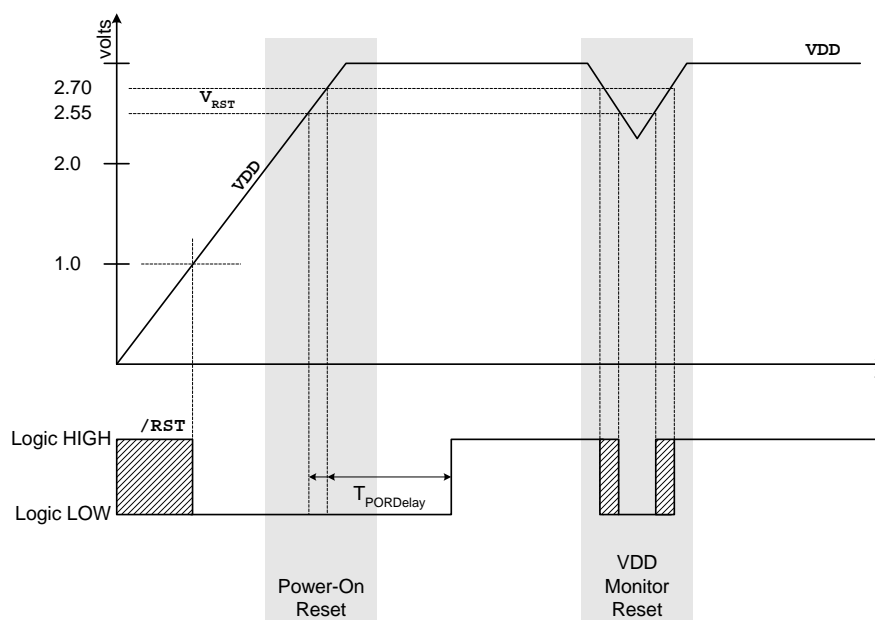

Figure 10.2. Power-On and  $V_{\text{DD}}$  Monitor Reset Timing

## 10.2. Power-Fail Reset/ $V_{\text{DD}}$ Monitor

When a power-down transition or power irregularity causes  $V_{\text{DD}}$  to drop below  $V_{\text{RST}}$ , the power supply monitor will drive the  $\overline{\text{RST}}$  pin low and hold the CIP-51 in a reset state (see Figure 10.2). When  $V_{\text{DD}}$  returns to a level above  $V_{\text{RST}}$ , the CIP-51 will be released from the reset state. Note that even though internal data memory contents are not altered by the power-fail reset, it is impossible to determine if  $V_{\text{DD}}$  dropped below the level required for data retention. If the PORSF flag reads '1', the data may no longer be valid. The  $V_{\text{DD}}$  monitor is disabled after power-on resets; however its defined state (enabled/disabled) is not altered by any other reset source. For example, if the  $V_{\text{DD}}$  monitor is enabled and a software reset is performed, the  $V_{\text{DD}}$  monitor will still be enabled after the reset.

**Important Note:** The  $V_{DD}$  monitor must be enabled before it is selected as a reset source. Selecting the  $V_{DD}$  monitor as a reset source before it is enabled and stabilized may cause a system reset. The procedure for configuring the  $V_{DD}$  monitor as a reset source is shown below:

- Step 1. Enable the  $V_{DD}$  monitor (VDMEN bit in VDM0CN = '1').
- Step 2. Wait for the  $V_{DD}$  monitor to stabilize (see Table 10.1 for the  $V_{DD}$  Monitor turn-on time).
- Step 3. Select the  $V_{DD}$  monitor as a reset source (PORSF bit in RSTSRC = '1').

See Figure 10.2 for  $V_{DD}$  monitor timing; note that the reset delay is not incurred after a  $V_{DD}$  monitor reset. See Table 10.1 for complete electrical characteristics of the  $V_{DD}$  monitor.

## SFR Definition 10.1. VDM0CN: $V_{DD}$ Monitor Control

R/W	R	R	R	R	R	R	R	Reset Value
VDMEN	VDDSTAT	Reserved	Reserved	Reserved	Reserved	Reserved	Reserved	Variable
Bit7	Bit6	Bit5	Bit4	Bit3	Bit2	Bit1	Bit0	
SFR Address: 0xFF								
Bit7:	VDMEN: $V_{DD}$ Monitor Enable. This bit turns the $V_{DD}$ monitor circuit on/off. The $V_{DD}$ Monitor cannot generate system resets until it is also selected as a reset source in register RSTSRC (SFR Definition 10.2). The $V_{DD}$ Monitor must be allowed to stabilize before it is selected as a reset source. <b>Selecting the <math>V_{DD}</math> monitor as a reset source before it has stabilized may generate a system reset.</b> See Table 10.1 for the minimum $V_{DD}$ Monitor turn-on time. 0: $V_{DD}$ Monitor Disabled. 1: $V_{DD}$ Monitor Enabled.							
Bit6:	VDD STAT: $V_{DD}$ Status. This bit indicates the current power supply status ( $V_{DD}$ Monitor output). 0: $V_{DD}$ is at or below the $V_{DD}$ monitor threshold. 1: $V_{DD}$ is above the $V_{DD}$ monitor threshold.							
Bits5–0:	Reserved. Read = 000000b. Write = don't care.							

### 10.3. External Reset

The external  $\overline{RST}$  pin provides a means for external circuitry to force the device into a reset state. Asserting an active-low signal on the  $\overline{RST}$  pin generates a reset; an external pullup and/or decoupling of the  $\overline{RST}$  pin may be necessary to avoid erroneous noise-induced resets. See Table 10.1 for complete  $\overline{RST}$  pin specifications. The PINRSF flag (RSTSRC.0) is set on exit from an external reset.

### 10.4. Missing Clock Detector Reset

The Missing Clock Detector (MCD) is a one-shot circuit that is triggered by the system clock. If the system clock remains high or low for more than 100  $\mu$ s, the one-shot will time out and generate a reset. After a MCD reset, the MCDRSF flag (RSTSRC.2) will read '1', signifying the MCD as the reset source; otherwise, this bit reads '0'. Writing a '1' to the MCDRSF bit enables the Missing Clock Detector; writing a '0' disables it. The state of the  $\overline{RST}$  pin is unaffected by this reset.

## 10.5. Comparator0 Reset

Comparator0 can be configured as a reset source by writing a '1' to the CORSEF flag (RSTSRC.5). Comparator0 should be enabled and allowed to settle prior to writing to CORSEF to prevent any turn-on chatter on the output from generating an unwanted reset. The Comparator0 reset is active-low: if the non-inverting input voltage (on CP0+) is less than the inverting input voltage (on CP0-), the device is put into the reset state. After a Comparator0 reset, the CORSEF flag (RSTSRC.5) will read '1' signifying Comparator0 as the reset source; otherwise, this bit reads '0'. The state of the  $\overline{\text{RST}}$  pin is unaffected by this reset.

## 10.6. PCA Watchdog Timer Reset

The programmable Watchdog Timer (WDT) function of the Programmable Counter Array (PCA) can be used to prevent software from running out of control during a system malfunction. The PCA WDT function can be enabled or disabled by software as described in [Section "19.3. Watchdog Timer Mode" on page 201](#); the WDT is enabled and clocked by SYSCLK / 12 following any reset. If a system malfunction prevents user software from updating the WDT, a reset is generated and the WDTRSF bit (RSTSRC.3) is set to '1'. The state of the RST pin is unaffected by this reset.

## 10.7. Flash Error Reset

If a Flash read/write/erase or program read targets an illegal address, a system reset is generated. This may occur due to any of the following:

- A Flash write or erase is attempted above user code space. This occurs when PSWE is set to '1' and a MOVX write operation targets an address above address 0x1DFF.
- A Flash read is attempted above user code space. This occurs when a MOVC operation targets an address above address 0x1DFF.
- A Program read is attempted above user code space. This occurs when user code attempts to branch to an address above 0x1DFF.
- A Flash read, write or erase attempt is restricted due to a Flash security setting (see [Section "11.3. Security Options" on page 105](#)).

The FERROR bit (RSTSRC.6) is set following a Flash error reset. The state of the  $\overline{\text{RST}}$  pin is unaffected by this reset.

## 10.8. Software Reset

Software may force a reset by writing a '1' to the SWRSF bit (RSTSRC.4). The SWRSF bit will read '1' following a software forced reset. The state of the  $\overline{\text{RST}}$  pin is unaffected by this reset.

## SFR Definition 10.2. RSTSRC: Reset Source

R	R	R/W	R/W	R	R/W	R/W	R	Reset Value
-	FERROR	C0RSEF	SWRSF	WDTRSF	MCDRSF	PORSF	PINRSF	Variable
Bit7	Bit6	Bit5	Bit4	Bit3	Bit2	Bit1	Bit0	

SFR Address: 0xEF

**Note:** Do not use read-modify-write operations (ORL, ANL) on this register.

Bit7: UNUSED. Read = 0. Write = don't care.

Bit6: FERROR: Flash Error Indicator.  
0: Source of last reset was not a Flash read/write/erase error.  
1: Source of last reset was a Flash read/write/erase error.

Bit5: C0RSEF: Comparator0 Reset Enable and Flag.  
0: **Read:** Source of last reset was not Comparator0. **Write:** Comparator0 is not a reset source.  
1: **Read:** Source of last reset was Comparator0. **Write:** Comparator0 is a reset source (active-low).

Bit4: SWRSF: Software Reset Force and Flag.  
0: **Read:** Source of last reset was not a write to the SWRSF bit. **Write:** No Effect.  
1: **Read:** Source of last reset was a write to the SWRSF bit. **Write:** Forces a system reset.

Bit3: WDTRSF: Watchdog Timer Reset Flag.  
0: Source of last reset was not a WDT timeout.  
1: Source of last reset was a WDT timeout.

Bit2: MCDRSF: Missing Clock Detector Flag.  
0: **Read:** Source of last reset was not a Missing Clock Detector timeout. **Write:** Missing Clock Detector disabled.  
1: **Read:** Source of last reset was a Missing Clock Detector timeout. **Write:** Missing Clock Detector enabled; triggers a reset if a missing clock condition is detected.

Bit1: PORSF: Power-On Reset Force and Flag.  
This bit is set anytime a power-on reset occurs. Writing this bit enables/disables the  $V_{DD}$  monitor as a reset source. **Note: writing '1' to this bit before the  $V_{DD}$  monitor is enabled and stabilized may cause a system reset.** See register VDM0CN (SFR Definition 10.1)  
0: **Read:** Last reset was not a power-on or  $V_{DD}$  monitor reset. **Write:**  $V_{DD}$  monitor is not a reset source.  
1: **Read:** Last reset was a power-on or  $V_{DD}$  monitor reset; all other reset flags indeterminate. **Write:**  $V_{DD}$  monitor is a reset source.

Bit0: PINRSF: HW Pin Reset Flag.  
0: Source of last reset was not RST pin.  
1: Source of last reset was RST pin.

# C8051F330/1/2/3/4/5

**Table 10.1. Reset Electrical Characteristics**

–40 to +85 °C unless otherwise specified.

Parameter	Conditions	Min	Typ	Max	Units
$\overline{\text{RST}}$ Output Low Voltage	$I_{OL} = 8.5 \text{ mA}$ , $V_{DD} = 2.7 \text{ V to } 3.6 \text{ V}$	—	—	0.6	V
$\overline{\text{RST}}$ Input High Voltage		$0.7 \times V_{DD}$	—	—	V
$\overline{\text{RST}}$ Input Low Voltage		—	—	$0.3 \times V_{DD}$	
$\overline{\text{RST}}$ Input Pullup Current	$\overline{\text{RST}} = 0.0 \text{ V}$	—	25	40	$\mu\text{A}$
$V_{DD}$ POR Threshold ( $V_{RST}$ )		2.40	2.55	2.70	V
Missing Clock Detector Time-out	Time from last system clock rising edge to reset initiation	100	220	600	$\mu\text{s}$
Reset Time Delay	Delay between release of any reset source and code execution at location 0x0000	—	—	32	$\mu\text{s}$
Minimum $\overline{\text{RST}}$ Low Time to Generate a System Reset		15	—	—	$\mu\text{s}$
$V_{DD}$ Monitor Turn-on Time		100	—	—	$\mu\text{s}$
$V_{DD}$ Monitor Supply Current		—	20	50	$\mu\text{A}$

## 11. Flash Memory

On-chip, re-programmable Flash memory is included for program code and non-volatile data storage. The Flash memory can be programmed in-system, a single byte at a time, through the C2 interface or by software using the MOVX instruction. Once cleared to logic 0, a Flash bit must be erased to set it back to logic 1. Flash bytes would typically be erased (set to 0xFF) before being reprogrammed. The write and erase operations are automatically timed by hardware for proper execution; data polling to determine the end of the write/erase operation is not required. Code execution is stalled during a Flash write/erase operation. Refer to Table 11.1 for complete Flash memory electrical characteristics.

### 11.1. Programming The Flash Memory

The simplest means of programming the Flash memory is through the C2 interface using programming tools provided by Silicon Labs or a third party vendor. This is the only means for programming a non-initialized device. For details on the C2 commands to program Flash memory, see [Section “20. C2 Interface” on page 209](#).

**To ensure the integrity of Flash contents, it is strongly recommended that the on-chip  $V_{DD}$  Monitor be enabled in any system that includes code that writes and/or erases Flash memory from software. See [Section 11.4](#) for more details.**

#### 11.1.1. Flash Lock and Key Functions

Flash writes and erases by user software are protected with a lock and key function. The Flash Lock and Key Register (FLKEY) must be written with the correct key codes, in sequence, before Flash operations may be performed. The key codes are: 0xA5, 0xF1. The timing does not matter, but the codes must be written in order. If the key codes are written out of order, or the wrong codes are written, Flash writes and erases will be disabled until the next system reset. Flash writes and erases will also be disabled if a Flash write or erase is attempted before the key codes have been written properly. The Flash lock resets after each write or erase; the key codes must be written again before a following Flash operation can be performed. The FLKEY register is detailed in SFR Definition 11.2.

#### 11.1.2. Flash Erase Procedure

The Flash memory can be programmed by software using the MOVX write instruction with the address and data byte to be programmed provided as normal operands. Before writing to Flash memory using MOVX, Flash write operations must be enabled by: (1) setting the PSWE Program Store Write Enable bit (PSCTL.0) to logic 1 (this directs the MOVX writes to target Flash memory); and (2) Writing the Flash key codes in sequence to the Flash Lock register (FLKEY). The PSWE bit remains set until cleared by software.

A write to Flash memory can clear bits to logic 0 but cannot set them; only an erase operation can set bits to logic 1 in Flash. **A byte location to be programmed should be erased before a new value is written.** The Flash memory is organized in 512-byte pages. The erase operation applies to an entire page (setting all bytes in the page to 0xFF). To erase an entire 512-byte page, perform the following steps:

- Step 1. Disable interrupts (recommended).
- Step 2. Set the PSEE bit (register PSCTL).
- Step 3. Set the PSWE bit (register PSCTL).
- Step 4. Write the first key code to FLKEY: 0xA5.
- Step 5. Write the second key code to FLKEY: 0xF1.
- Step 6. Using the MOVX instruction, write a data byte to any location within the 512-byte page to be erased.
- Step 7. Clear the PSWE and PSEE bits.

# C8051F330/1/2/3/4/5

## 11.1.3. Flash Write Procedure

Flash bytes are programmed by software with the following sequence:

- Step 1. Disable interrupts (recommended).
- Step 2. Erase the 512-byte Flash page containing the target location, as described in [Section 11.1.2](#).
- Step 3. Set the PSWE bit (register PSCTL).
- Step 4. Clear the PSEE bit (register PSCTL).
- Step 5. Write the first key code to FLKEY: 0xA5.
- Step 6. Write the second key code to FLKEY: 0xF1.
- Step 7. Using the MOVX instruction, write a single data byte to the desired location within the 512-byte sector.
- Step 8. Clear the PSWE bit.

Steps 5–7 must be repeated for each byte to be written. After Flash writes are complete, PSWE should be cleared so that MOVX instructions do not target program memory.

**Table 11.1. Flash Electrical Characteristics**

$V_{DD} = 2.7$  to  $3.6$  V;  $-40$  to  $+85$  °C unless otherwise specified.

Parameter	Conditions	Min	Typ	Max	Units
Flash Size	C8051F330/1	8192*	—	—	bytes
	C8051F332/3	4096	—	—	
	C8051F334/5	2048	—	—	
Endurance		20 k	100 k	—	Erase/Write
Erase Cycle Time	25 MHz System Clock	10	15	20	ms
Write Cycle Time	25 MHz System Clock	40	55	70	μs

**\*Note:** 512 bytes at addresses 0x1E00 to 0x1FFF are reserved.

## 11.2. Non-volatile Data Storage

The Flash memory can be used for non-volatile data storage as well as program code. This allows data such as calibration coefficients to be calculated and stored at run time. Data is written using the MOVX write instruction and read using the MOVC instruction. Note: MOVX read instructions always target XRAM.



## 11.3. Security Options

The CIP-51 provides security options to protect the Flash memory from inadvertent modification by software as well as to prevent the viewing of proprietary program code and constants. The Program Store Write Enable (bit PSWE in register PSCTL) and the Program Store Erase Enable (bit PSEE in register PSCTL) bits protect the Flash memory from accidental modification by software. PSWE must be explicitly set to '1' before software can modify the Flash memory; both PSWE and PSEE must be set to '1' before software can erase Flash memory. Additional security features prevent proprietary program code and data constants from being read or altered across the C2 interface.

A Security Lock Byte located at the last byte of Flash user space offers protection of the Flash program memory from access (reads, writes, or erases) by unprotected code or the C2 interface. The Flash security mechanism allows the user to lock  $n$  512-byte Flash pages, starting at page 0 (addresses 0x0000 to 0x01FF), where  $n$  is the 1's complement number represented by the Security Lock Byte. **Note that the page containing the Flash Security Lock Byte is unlocked when no other Flash pages are locked (all bits of the Lock Byte are '1') and locked when any other Flash pages are locked (any bit of the Lock Byte is '0').** See example below.

Security Lock Byte:	11111101b
1s Complement:	00000010b
Flash pages locked:	3 (First two Flash pages + Lock Byte Page)
Addresses locked:	0x0000 to 0x03FF (first two Flash pages) and 0x1C00 to 0x1DFF or 0x0E00 to 0x0FFF or 0x0600 to 0x07FF (Lock Byte Page)

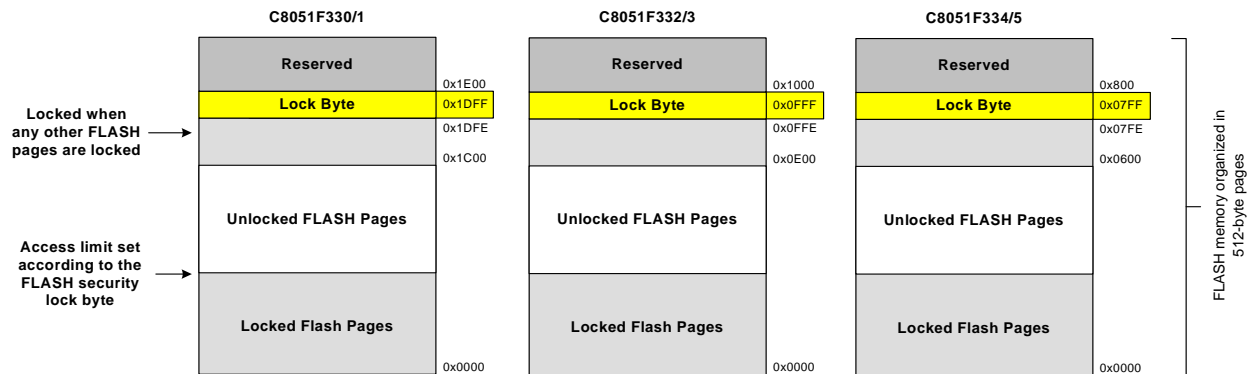

Figure 11.2. Flash Program Memory Map

# C8051F330/1/2/3/4/5

The level of Flash security depends on the Flash access method. The three Flash access methods that can be restricted are reads, writes, and erases from the C2 debug interface, user firmware executing on unlocked pages, and user firmware executing on locked pages. Table 11.2 summarizes the Flash security features of the 'F330/1/2/3/4/5 devices.

**Table 11.2. Flash Security Summary**

Action	C2 Debug Interface	User Firmware executing from:	
		an unlocked page	a locked page
Read, Write or Erase unlocked pages (except page with Lock Byte)	Permitted	Permitted	Permitted
Read, Write or Erase locked pages (except page with Lock Byte)	Not Permitted	Flash Error Reset	Permitted
Read or Write page containing Lock Byte (if no pages are locked)	Permitted	Permitted	Permitted
Read or Write page containing Lock Byte (if any page is locked)	Not Permitted	Flash Error Reset	Permitted
Read contents of Lock Byte (if no pages are locked)	Permitted	Permitted	Permitted
Read contents of Lock Byte (if any page is locked)	Not Permitted	Flash Error Reset	Permitted
Erase page containing Lock Byte (if no pages are locked)	Permitted	Flash Error Reset	Flash Error Reset
Erase page containing Lock Byte - Unlock all pages (if any page is locked)	C2 Device Erase Only	Flash Error Reset	Flash Error Reset
Lock additional pages (change '1's to '0's in the Lock Byte)	Not Permitted	Flash Error Reset	Flash Error Reset
Unlock individual pages (change '0's to '1's in the Lock Byte)	Not Permitted	Flash Error Reset	Flash Error Reset
Read, Write or Erase Reserved Area	Not Permitted	Flash Error Reset	Flash Error Reset

C2 Device Erase - Erases all Flash pages including the page containing the Lock Byte.

Flash Error Reset - Not permitted; Causes Flash Error Device Reset (FERROR bit in RSTSRC is '1' after reset).

- All prohibited operations that are performed via the C2 interface are ignored (do not cause device reset).
- Locking any Flash page also locks the page containing the Lock Byte.
- Once written to, the Lock Byte cannot be modified except by performing a C2 Device Erase.
- If user code writes to the Lock Byte, the Lock does not take effect until the next device reset.

## 11.4. Flash Write and Erase Guidelines

Any system which contains routines which write or erase Flash memory from software involves some risk that the write or erase routines will execute unintentionally if the CPU is operating outside its specified operating range of  $V_{DD}$ , system clock frequency, or temperature. This accidental execution of Flash modifying code can result in alteration of Flash memory contents causing a system failure that is only recoverable by re-Flashing the code in the device.

The following guidelines are recommended for any system which contains routines which write or erase Flash from code.

### 11.4.1. $V_{DD}$ Maintenance and the $V_{DD}$ monitor

1. If the system power supply is subject to voltage or current "spikes," add sufficient transient protection devices to the power supply to ensure that the supply voltages listed in the Absolute Maximum Ratings table are not exceeded.
2. Make certain that the minimum  $V_{DD}$  rise time specification of 1 ms is met. If the system cannot meet this rise time specification, then add an external  $V_{DD}$  brownout circuit to the  $\overline{RST}$  pin of the device that holds the device in reset until  $V_{DD}$  reaches 2.7 V and re-asserts  $\overline{RST}$  if  $V_{DD}$  drops below 2.7 V.
3. Enable the on-chip  $V_{DD}$  monitor and enable the  $V_{DD}$  monitor as a reset source as early in code as possible. This should be the first set of instructions executed after the Reset Vector. For 'C'-based systems, this will involve modifying the startup code added by the 'C' compiler. See your compiler documentation for more details. Make certain that there are no delays in software between enabling the  $V_{DD}$  monitor and enabling the  $V_{DD}$  monitor as a reset source. Code examples showing this can be found in "AN201: Writing to Flash from Firmware", available from the Silicon Laboratories web site.
4. As an added precaution, explicitly enable the  $V_{DD}$  monitor and enable the  $V_{DD}$  monitor as a reset source inside the functions that write and erase Flash memory. The  $V_{DD}$  monitor enable instructions should be placed just after the instruction to set PSWE to a '1', but before the Flash write or erase operation instruction.
5. Make certain that all writes to the RSTSRC (Reset Sources) register use direct assignment operators and explicitly DO NOT use the bit-wise operators (such as AND or OR). For example, "RSTSRC = 0x02" is correct. "RSTSRC |= 0x02" is incorrect.
6. Make certain that all writes to the RSTSRC register explicitly set the PORSF bit to a '1'. Areas to check are initialization code which enables other reset sources, such as the Missing Clock Detector or Comparator, for example, and instructions which force a Software Reset. A global search on "RSTSRC" can quickly verify this.

### 11.4.2. PSWE Maintenance

7. Reduce the number of places in code where the PSWE bit (b0 in PSCTL) is set to a '1'. There should be exactly one routine in code that sets PSWE to a '1' to write Flash bytes and one routine in code that sets PSWE and PSEE both to a '1' to erase Flash pages.
8. Minimize the number of variable accesses while PSWE is set to a '1'. Handle pointer address updates and loop variable maintenance outside the "PSWE = 1; ... PSWE = 0;" area. Code examples showing this can be found in AN201, "Writing to Flash from Firmware", available from the Silicon Laboratories web site.
9. Disable interrupts prior to setting PSWE to a '1' and leave them disabled until after PSWE has been reset to '0'. Any interrupts posted during the Flash write or erase operation will be ser-

# C8051F330/1/2/3/4/5

vised in priority order after the Flash operation has been completed and interrupts have been re-enabled by software.

10. Make certain that the Flash write and erase pointer variables are not located in XRAM. See your compiler documentation for instructions regarding how to explicitly locate variables in different memory areas.
11. Add address bounds checking to the routines that write or erase Flash memory to ensure that a routine called with an illegal address does not result in modification of the Flash.

## 11.4.3. System Clock

12. If operating from an external crystal, be advised that crystal performance is susceptible to electrical interference and is sensitive to layout and to changes in temperature. If the system is operating in an electrically noisy environment, use the internal oscillator or use an external CMOS clock.
13. If operating from the external oscillator, switch to the internal oscillator during Flash write or erase operations. The external oscillator can continue to run, and the CPU can switch back to the external oscillator after the Flash operation has completed.

Additional Flash recommendations and example code can be found in AN201, "Writing to Flash from Firmware", available from the Silicon Laboratories web site.

### SFR Definition 11.1. PSCTL: Program Store R/W Control

R	R	R	R	R	R	R/W	R/W	Reset Value
—	—	—	—	—	—	PSEE	PSWE	00000000
Bit7	Bit6	Bit5	Bit4	Bit3	Bit2	Bit1	Bit0	

SFR Address: 0x8F

Bits7–2: UNUSED: Read = 000000b, Write = don't care.

Bit1: PSEE: Program Store Erase Enable  
 Setting this bit (in combination with PSWE) allows an entire page of Flash program memory to be erased. If this bit is logic 1 and Flash writes are enabled (PSWE is logic 1), a write to Flash memory using the MOVX instruction will erase the entire page that contains the location addressed by the MOVX instruction. The value of the data byte written does not matter.  
 0: Flash program memory erasure disabled.  
 1: Flash program memory erasure enabled.

Bit0: PSWE: Program Store Write Enable  
 Setting this bit allows writing a byte of data to the Flash program memory using the MOVX write instruction. The Flash location should be erased before writing data.  
 0: Writes to Flash program memory disabled.  
 1: Writes to Flash program memory enabled; the MOVX write instruction targets Flash memory.

## SFR Definition 11.2. FLKEY: Flash Lock and Key

R/W	R/W	R/W	R/W	R/W	R/W	R/W	R/W	Reset Value
								00000000
Bit7	Bit6	Bit5	Bit4	Bit3	Bit2	Bit1	Bit0	

SFR Address: 0xB7

Bits7–0: FLKEY: Flash Lock and Key Register

**Write:**  
 This register provides a lock and key function for Flash erasures and writes. Flash writes and erases are enabled by writing 0xA5 followed by 0xF1 to the FLKEY register. Flash writes and erases are automatically disabled after the next write or erase is complete. If any writes to FLKEY are performed incorrectly, or if a Flash write or erase operation is attempted while these operations are disabled, the Flash will be permanently locked from writes or erasures until the next device reset. If an application never writes to Flash, it can intentionally lock the Flash by writing a non-0xA5 value to FLKEY from software.

**Read:**  
 When read, bits 1–0 indicate the current Flash lock state.

- 00: Flash is write/erase locked.
- 01: The first key code has been written (0xA5).
- 10: Flash is unlocked (writes/erases allowed).
- 11: Flash writes/erases disabled until the next reset.

## SFR Definition 11.3. FLSC: Flash Scale

R/W	R/W	R/W	R/W	R/W	R/W	R/W	R/W	Reset Value
FOSE	Reserved	Reserved	Reserved	Reserved	Reserved	Reserved	Reserved	10000000
Bit7	Bit6	Bit5	Bit4	Bit3	Bit2	Bit1	Bit0	

SFR Address: 0xB6

Bit7: FOSE: Flash One-shot Enable  
 This bit enables the Flash read one-shot. When the Flash one-shot disabled, the Flash sense amps are enabled for a full clock cycle during Flash reads. At system clock frequencies below 10 MHz, disabling the Flash one-shot will increase system power consumption.

- 0: Flash one-shot disabled.
- 1: Flash one-shot enabled.

Bits6–0: RESERVED. Read = 0. Must Write 0.

# C8051F330/1/2/3/4/5

---

## 12. External RAM

The C8051F330/1/2/3/4/5 devices include 512 bytes of RAM mapped into the external data memory space. All of these address locations may be accessed using the external move instruction (MOVX) and the data pointer (DPTR), or using MOVX indirect addressing mode. If the MOVX instruction is used with an 8-bit address operand (such as @R1), then the high byte of the 16-bit address is provided by the External Memory Interface Control Register (EMI0CN as shown in SFR Definition 12.1). Note: the MOVX instruction is also used for writes to the Flash memory. See [Section “11. Flash Memory” on page 103](#) for details. The MOVX instruction accesses XRAM by default.

For a 16-bit MOVX operation (@DPTR), the upper 7 bits of the 16-bit external data memory address word are "don't cares". As a result, the 512-byte RAM is mapped modulo style over the entire 64 k external data memory address range. For example, the XRAM byte at address 0x0000 is shadowed at addresses 0x0200, 0x0400, 0x0600, 0x0800, etc. This is a useful feature when performing a linear memory fill, as the address pointer doesn't have to be reset when reaching the RAM block boundary.

### SFR Definition 12.1. EMI0CN: External Memory Interface Control

R/W	R/W	R/W	R/W	R/W	R/W	R/W	R/W	Reset Value
—	—	—	—	—	—	—	PGSEL	00000000
Bit7	Bit6	Bit5	Bit4	Bit3	Bit2	Bit1	Bit0	

SFR Address: 0xAA

Bits7–1: UNUSED. Read = 0000000b. Write = don't care.  
 Bit 0: PGSEL: XRAM Page Select.  
 The EMI0CN register provides the high byte of the 16-bit external data memory address when using an 8-bit MOVX command, effectively selecting a 256-byte page of RAM. Since the upper (unused) bits of the register are always zero, the PGSEL determines which page of XRAM is accessed.

For Example: If EMI0CN = 0x01, addresses 0x0100 through 0x01FF will be accessed.

# C8051F330/1/2/3/4/5

---



## 13. Oscillators

C8051F330/1/2/3/4/5 devices include a programmable internal high-frequency oscillator, a programmable internal low-frequency oscillator, and an external oscillator drive circuit. The internal high-frequency oscillator can be enabled/disabled and calibrated using the OSCICN and OSCICL registers, as shown in Figure 13.1. The internal low-frequency oscillator can be enabled/disabled and calibrated using the OSCLCN register, as shown in SFR Definition 13.3. The system clock can be sourced by the external oscillator circuit or either internal oscillator. Both internal oscillators offer a selectable post-scaling feature. The internal oscillators' electrical specifications are given in Table 13.1 on page 122.

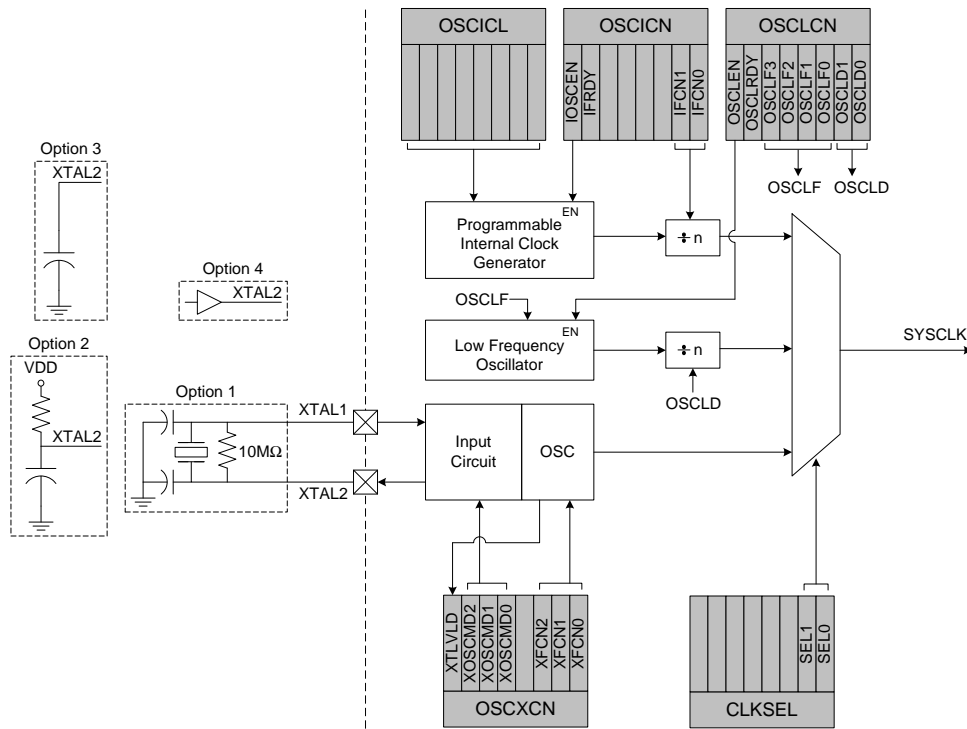

**Figure 13.1. Oscillator Diagram**

### 13.1. Programmable Internal High-Frequency (H-F) Oscillator

All C8051F330/1/2/3/4/5 devices include a programmable internal high-frequency oscillator that defaults as the system clock after a system reset. The internal oscillator period can be adjusted via the OSCICL register as defined by SFR Definition 13.1.

On C8051F330/1/2/3/4/5 devices, OSCICL is factory calibrated to obtain a 24.5 MHz base frequency.

Electrical specifications for the precision internal oscillator are given in Table 13.1 on page 122. Note that the system clock may be derived from the programmed internal oscillator divided by 1, 2, 4, or 8, as defined by the IFCN bits in register OSCICN. The divide value defaults to 8 following a reset.

# C8051F330/1/2/3/4/5

## SFR Definition 13.1. OSCICL: Internal H-F Oscillator Calibration

R	R/W	R/W	R/W	R/W	R/W	R/W	R/W	Reset Value
-								Variable
Bit7	Bit6	Bit5	Bit4	Bit3	Bit2	Bit1	Bit0	SFR Address: 0xB3

Bit7: UNUSED. Read = 0. Write = don't care.  
Bits 6–0: OSCICL: Internal Oscillator Calibration Register.  
This register determines the internal oscillator period. When set to 0000000b, the H-F oscillator operates at its fastest setting. When set to 1111111b, the H-F oscillator operates at its slowest setting. On C8051F330/1/2/3/4/5 devices, the reset value is factory calibrated to generate an internal oscillator frequency of 24.5 MHz.

## SFR Definition 13.2. OSCICN: Internal H-F Oscillator Control

R/W	R	R	R	R	R	R/W	R/W	Reset Value
IOSCEN	IFRDY	-	-	-	-	IFCN1	IFCN0	11000000
Bit7	Bit6	Bit5	Bit4	Bit3	Bit2	Bit1	Bit0	SFR Address: 0xB2

Bit7: IOSCEN: Internal H-F Oscillator Enable Bit.  
0: Internal H-F Oscillator Disabled.  
1: Internal H-F Oscillator Enabled.  
Bit6: IFRDY: Internal H-F Oscillator Frequency Ready Flag.  
0: Internal H-F Oscillator is not running at programmed frequency.  
1: Internal H-F Oscillator is running at programmed frequency.  
Bits5–2: UNUSED. Read = 0000b, Write = don't care.  
Bits1–0: IFCN1–0: Internal H-F Oscillator Frequency Control Bits.  
00: SYSCLK derived from Internal H-F Oscillator divided by 8.  
01: SYSCLK derived from Internal H-F Oscillator divided by 4.  
10: SYSCLK derived from Internal H-F Oscillator divided by 2.  
11: SYSCLK derived from Internal H-F Oscillator divided by 1.

## 13.2. Programmable Internal Low-Frequency (L-F) Oscillator

All C8051F330/1/2/3/4/5 devices include a programmable low-frequency internal oscillator, which is calibrated to a nominal frequency of 80 kHz. The low-frequency oscillator circuit includes a divider that can be changed to divide the clock by 1, 2, 4, or 8, using the OSCLD bits in the OSCLCN register (see SFR Definition 13.3). Additionally, the OSCLF bits (OSCLCN5:2) can be used to adjust the oscillator's output frequency.

### 13.2.1. Calibrating the Internal L-F Oscillator

Timers 2 and 3 include capture functions that can be used to capture the oscillator frequency, when running from a known time base. When either Timer 2 or Timer 3 is configured for L-F Oscillator Capture Mode, a falling edge (Timer 2) or rising edge (Timer 3) of the low-frequency oscillator's output will cause a capture event on the corresponding timer. As a capture event occurs, the current timer value (TMRnH:TMRnL) is copied into the timer reload registers (TMRnRLH:TMRnRLL). By recording the difference between two successive timer capture values, the low-frequency oscillator's period can be calculated. The OSCLF bits can then be adjusted to produce the desired oscillator frequency.

### SFR Definition 13.3. OSCLCN: Internal L-F Oscillator Control

R/W	R	R/W	R/W	R/W	R/W	R/W	R/W	Reset Value
OSCLCN7	OSCLCN6	OSCLCN5	OSCLCN4	OSCLCN3	OSCLCN2	OSCLCN1	OSCLCN0	00vvvv00
Bit7	Bit6	Bit5	Bit4	Bit3	Bit2	Bit1	Bit0	SFR Address: 0xE3
<p>Bit7: OSCLCN7: Internal L-F Oscillator Enable. 0: Internal L-F Oscillator Disabled. 1: Internal L-F Oscillator Enabled.</p> <p>Bit6: OSCLCN6: Internal L-F Oscillator Ready. 0: Internal L-F Oscillator frequency not stabilized. 1: Internal L-F Oscillator frequency stabilized.</p> <p>Bits5–2: OSCLCN[3:0]: Internal L-F Oscillator Frequency Control bits. Fine-tune control bits for the Internal L-F oscillator frequency. When set to 0000b, the L-F oscillator operates at its fastest setting. When set to 1111b, the L-F oscillator operates at its slowest setting.</p> <p>Bits1–0: OSCLCN[1:0]: Internal L-F Oscillator Divider Select. 00: Divide by 8 selected. 01: Divide by 4 selected. 10: Divide by 2 selected. 11: Divide by 1 selected.</p>								

# C8051F330/1/2/3/4/5

---

## 13.3. External Oscillator Drive Circuit

The external oscillator circuit may drive an external crystal, ceramic resonator, capacitor, or RC network. A CMOS clock may also provide a clock input. For a crystal or ceramic resonator configuration, the crystal/resonator must be wired across the XTAL1 and XTAL2 pins as shown in Option 1 of Figure 13.1. A 10 M $\Omega$  resistor also must be wired across the XTAL2 and XTAL1 pins for the crystal/resonator configuration. In RC, capacitor, or CMOS clock configuration, the clock source should be wired to the XTAL2 pin as shown in Option 2, 3, or 4 of Figure 13.1. The type of external oscillator must be selected in the OSCXCN register, and the frequency control bits (XFCN) must be selected appropriately (see SFR Definition 13.4).

**Important Note on External Oscillator Usage:** Port pins must be configured when using the external oscillator circuit. When the external oscillator drive circuit is enabled in crystal/resonator mode, Port pins P0.2 and P0.3 are used as XTAL1 and XTAL2 respectively. When the external oscillator drive circuit is enabled in capacitor, RC, or CMOS clock mode, Port pin P0.3 is used as XTAL2. The Port I/O Crossbar should be configured to skip the Port pins used by the oscillator circuit; see [Section “14.1. Priority Crossbar Decoder” on page 125](#) for Crossbar configuration. Additionally, when using the external oscillator circuit in crystal/resonator, capacitor, or RC mode, the associated Port pins should be configured as **analog inputs**. In CMOS clock mode, the associated pin should be configured as a **digital input**. See [Section “14.2. Port I/O Initialization” on page 127](#) for details on Port input mode selection.

## SFR Definition 13.4. OSCXCN: External Oscillator Control

R	R/W	R/W	R/W	R	R/W	R/W	R/W	Reset Value
XTLVLD	XOSCND2	XOSCND1	XOSCND0	-	XFCN2	XFCN1	XFCN0	00000000
Bit7	Bit6	Bit5	Bit4	Bit3	Bit2	Bit1	Bit0	SFR Address: 0xB1

- Bit7: XTLVLD: Crystal Oscillator Valid Flag.  
(Read only when XOSCND = 11x.)  
0: Crystal Oscillator is unused or not yet stable.  
1: Crystal Oscillator is running and stable.
- Bits6–4: XOSCND2–0: External Oscillator Mode Bits.  
00x: External Oscillator circuit off.  
010: External CMOS Clock Mode.  
011: External CMOS Clock Mode with divide by 2 stage.  
100: RC Oscillator Mode.  
101: Capacitor Oscillator Mode.  
110: Crystal Oscillator Mode.  
111: Crystal Oscillator Mode with divide by 2 stage.
- Bit3: RESERVED. Read = 0, Write = don't care.
- Bits2–0: XFCN2–0: External Oscillator Frequency Control Bits.  
000–111: See table below:

XFCN	Crystal (XOSCND = 11x)	RC (XOSCND = 10x)	C (XOSCND = 10x)
000	$f \leq 32 \text{ kHz}$	$f \leq 25 \text{ kHz}$	K Factor = 0.87
001	$32 \text{ kHz} < f \leq 84 \text{ kHz}$	$25 \text{ kHz} < f \leq 50 \text{ kHz}$	K Factor = 2.6
010	$84 \text{ kHz} < f \leq 225 \text{ kHz}$	$50 \text{ kHz} < f \leq 100 \text{ kHz}$	K Factor = 7.7
011	$225 \text{ kHz} < f \leq 590 \text{ kHz}$	$100 \text{ kHz} < f \leq 200 \text{ kHz}$	K Factor = 22
100	$590 \text{ kHz} < f \leq 1.5 \text{ MHz}$	$200 \text{ kHz} < f \leq 400 \text{ kHz}$	K Factor = 65
101	$1.5 \text{ MHz} < f \leq 4 \text{ MHz}$	$400 \text{ kHz} < f \leq 800 \text{ kHz}$	K Factor = 180
110	$4 \text{ MHz} < f \leq 10 \text{ MHz}$	$800 \text{ kHz} < f \leq 1.6 \text{ MHz}$	K Factor = 664
111	$10 \text{ MHz} < f \leq 30 \text{ MHz}$	$1.6 \text{ MHz} < f \leq 3.2 \text{ MHz}$	K Factor = 1590

**CRYSTAL MODE** (Circuit from Figure 13.1, Option 1; XOSCND = 11x)  
Choose XFCN value to match crystal frequency.

**RC MODE** (Circuit from Figure 13.1, Option 2; XOSCND = 10x)  
Choose XFCN value to match frequency range:  
 $f = 1.23(10^3) / (R * C)$ , where  
f = frequency of clock in MHz  
C = capacitor value in pF  
R = Pullup resistor value in kΩ

**C MODE** (Circuit from Figure 13.1, Option 3; XOSCND = 10x)  
Choose K Factor (KF) for the oscillation frequency desired:  
 $f = KF / (C * V_{DD})$ , where  
f = frequency of clock in MHz  
C = capacitor value the XTAL2 pin in pF  
 $V_{DD}$  = Power Supply on MCU in volts

## 13.3.1. External Crystal Example

If a crystal or ceramic resonator is used as an external oscillator source for the MCU, the circuit should be configured as shown in Figure 13.1, Option 1. The External Oscillator Frequency Control value (XFCN) should be chosen from the Crystal column of the table in SFR Definition 13.4 (OSCXCN register). For example, an 11.0592 MHz crystal requires an XFCN setting of 111b and a 32.768 kHz Watch Crystal requires an XFCN setting of 001b. After an external 32.768 kHz oscillator is stabilized, the XFCN setting can be switched to 000 to save power. It is recommended to enable the missing clock detector before switching the system clock to any external oscillator source.

When the crystal oscillator is first enabled, the oscillator amplitude detection circuit requires a settling time to achieve proper bias. Introducing a delay of 1 ms between enabling the oscillator and checking the XTLVLD bit will prevent a premature switch to the external oscillator as the system clock. Switching to the external oscillator before the crystal oscillator has stabilized can result in unpredictable behavior. The recommended procedure is:

- Step 1. Force XTAL1 and XTAL2 to a low state. This involves enabling the Crossbar and writing '0' to port latches P0.2 and P0.3.
- Step 2. Configure XTAL1 and XTAL2 as analog inputs using register P0MDIN.
- Step 3. Enable the external oscillator.
- Step 4. Wait at least 1 ms.
- Step 5. Poll for XTLVLD => '1'.
- Step 6. Enable the Missing Clock Detector.
- Step 7. Switch the system clock to the external oscillator.

**Important Note on External Crystals:** Crystal oscillator circuits are quite sensitive to PCB layout. The crystal should be placed as close as possible to the XTAL pins on the device. The traces should be as short as possible and shielded with ground plane from any other traces which could introduce noise or interference.

The capacitors shown in the external crystal configuration provide the load capacitance required by the crystal for correct oscillation. These capacitors are "in series" as seen by the crystal and "in parallel" with the stray capacitance of the XTAL1 and XTAL2 pins.

**Note:** The desired load capacitance depends upon the crystal and the manufacturer. Please refer to the crystal data sheet when completing these calculations.

For example, a tuning-fork crystal of 32.768 kHz with a recommended load capacitance of 12.5 pF should use the configuration shown in Figure 13.1, Option 1. The total value of the capacitors and the stray capacitance of the XTAL pins should equal 25 pF. With a stray capacitance of 3 pF per pin, the 22 pF capacitors yield an equivalent capacitance of 12.5 pF across the crystal, as shown in Figure 13.2.

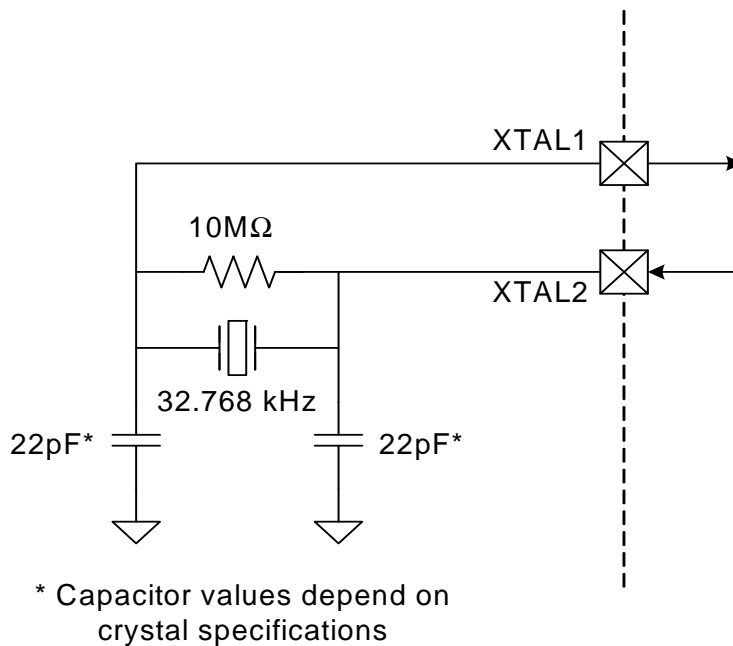

**Figure 13.2. External 32.768 kHz Quartz Crystal Oscillator Connection Diagram**

# C8051F330/1/2/3/4/5

---

## 13.3.2. External RC Example

If an RC network is used as an external oscillator source for the MCU, the circuit should be configured as shown in Figure 13.1, Option 2. The capacitor should be no greater than 100 pF; however for very small capacitors, the total capacitance may be dominated by parasitic capacitance in the PCB layout. To determine the required External Oscillator Frequency Control value (XFCN) in the OSCXCN Register, first select the RC network value to produce the desired frequency of oscillation. If the frequency desired is 100 kHz, let  $R = 246 \text{ k}\Omega$  and  $C = 50 \text{ pF}$ :

$$f = 1.23(10^3) / RC = 1.23 (10^3) / [246 \times 50] = 0.1 \text{ MHz} = 100 \text{ kHz}$$

Referring to the table in SFR Definition 13.4, the required XFCN setting is 010b.

## 13.3.3. External Capacitor Example

If a capacitor is used as an external oscillator for the MCU, the circuit should be configured as shown in Figure 13.1, Option 3. The capacitor should be no greater than 100 pF; however for very small capacitors, the total capacitance may be dominated by parasitic capacitance in the PCB layout. To determine the required External Oscillator Frequency Control value (XFCN) in the OSCXCN Register, select the capacitor to be used and find the frequency of oscillation from the equations below. Assume  $V_{DD} = 3.0 \text{ V}$  and  $f = 150 \text{ kHz}$ :

$$f = KF / (C \times V_{DD})$$
$$0.150 \text{ MHz} = KF / (C \times 3.0)$$

Since the frequency of roughly 150 kHz is desired, select the K Factor from the table in SFR Definition 13.4 (OSCXCN) as  $KF = 22$ :

$$0.150 \text{ MHz} = 22 / (C \times 3.0)$$
$$C \times 3.0 = 22 / 0.150 \text{ MHz}$$
$$C = 146.6 / 3.0 \text{ pF} = 48.8 \text{ pF}$$

Therefore, the XFCN value to use in this example is 011b and  $C = 50 \text{ pF}$ .



## 13.4. System Clock Selection

The internal oscillator requires little start-up time and may be selected as the system clock immediately following the OSCICN write that enables the internal oscillator. External crystals and ceramic resonators typically require a start-up time before they are settled and ready for use. The Crystal Valid Flag (XTLVLD in register OSCXCN) is set to '1' by hardware when the external oscillator is settled. **In crystal mode, to avoid reading a false XTLVLD, software should delay at least 1 ms between enabling the external oscillator and checking XTLVLD.** RC and C modes typically require no startup time.

The CLKSL[1:0] bits in register CLKSEL select which oscillator source is used as the system clock. CLKSL[1:0] must be set to 01b for the system clock to run from the external oscillator; however the external oscillator may still clock certain peripherals (timers, PCA) when the internal oscillator is selected as the system clock. The system clock may be switched on-the-fly between the internal oscillator, external oscillator, and Clock Multiplier so long as the selected clock source is enabled and has settled.

### SFR Definition 13.5. CLKSEL: Clock Select

R	R	R	R	R	R	R/W	R/W	Reset Value
-	-	-	-	-	-	CLKSL1	CLKSL0	00000000
Bit7	Bit6	Bit5	Bit4	Bit3	Bit2	Bit1	Bit0	SFR Address: 0xA9

Bits7–2: UNUSED. Read = 000000b, Write = don't care.  
 Bits1–0: CLKSL[1:0]: System Clock Source Select Bits.  
 00: SYSCLK derived from the Internal High-Frequency Oscillator and scaled per the IFCN bits in register OSCICN.  
 01: SYSCLK derived from the External Oscillator circuit.  
 10: SYSCLK derived from the Internal Low-Frequency Oscillator and scaled per the OSCLD bits in register OSCLCN.  
 11: reserved.

# C8051F330/1/2/3/4/5

**Table 13.1. Internal Oscillator Electrical Characteristics**

$V_{DD} = 2.7$  to  $3.6$  V;  $T_A = -40$  to  $+85$  °C unless otherwise specified

Parameter	Conditions	Min	Typ	Max	Units
<b>Internal High-Frequency Oscillator (Using Factory-Calibrated Settings)</b>					
Oscillator Frequency	IFCN = 11b	24	24.5	25	MHz
Oscillator Supply Current (from $V_{DD}$ )	25 °C, $V_{DD} = 3.0$ V, OSCICN.7 = 1	—	450	—	$\mu$ A
Power Supply Sensitivity	Constant Temperature	—	$0.3 \pm 0.1^*$	—	% / V
Temperature Sensitivity	Constant Supply	—	$50 \pm 10^*$	—	ppm / °C
<b>Internal Low-Frequency Oscillator (Using Factory-Calibrated Settings)</b>					
Oscillator Frequency	OSCLD = 11b	72	80	88	kHz
Oscillator Supply Current (from $V_{DD}$ )	25 °C, $V_{DD} = 3.0$ V, OSCLCN.7 = 1	—	5.5	—	$\mu$ A
Power Supply Sensitivity	Constant Temperature	—	$-3 \pm 0.1^*$	—	%/V
Temperature Sensitivity	Constant Supply	—	$20 \pm 8^*$	—	ppm/°C
<b>*Note:</b> Represents mean $\pm 1$ standard deviation.					

## 14. Port Input/Output

Digital and analog resources are available through 17 I/O pins. Port pins are organized as two byte-wide Ports and one 1-bit Port. Each of the Port pins can be defined as general-purpose I/O (GPIO) or analog input; Port pins P0.0 - P1.7 can be assigned to one of the internal digital resources as shown in Figure 14.3. The designer has complete control over which functions are assigned, limited only by the number of physical I/O pins. This resource assignment flexibility is achieved through the use of a Priority Crossbar Decoder. Note that the state of a Port I/O pin can always be read in the corresponding Port latch, regardless of the Crossbar settings.

The Crossbar assigns the selected internal digital resources to the I/O pins based on the Priority Decoder (Figure 14.3 and Figure 14.4). The registers XBR0 and XBR1, defined in SFR Definition 14.1 and SFR Definition 14.2, are used to select internal digital functions.

All Port I/Os are 5 V tolerant (refer to Figure 14.2 for the Port cell circuit). The Port I/O cells are configured as either push-pull or open-drain in the Port Output Mode registers (PnMDOUT, where n = 0,1). Complete Electrical Specifications for Port I/O are given in Table 14.1 on page 134.

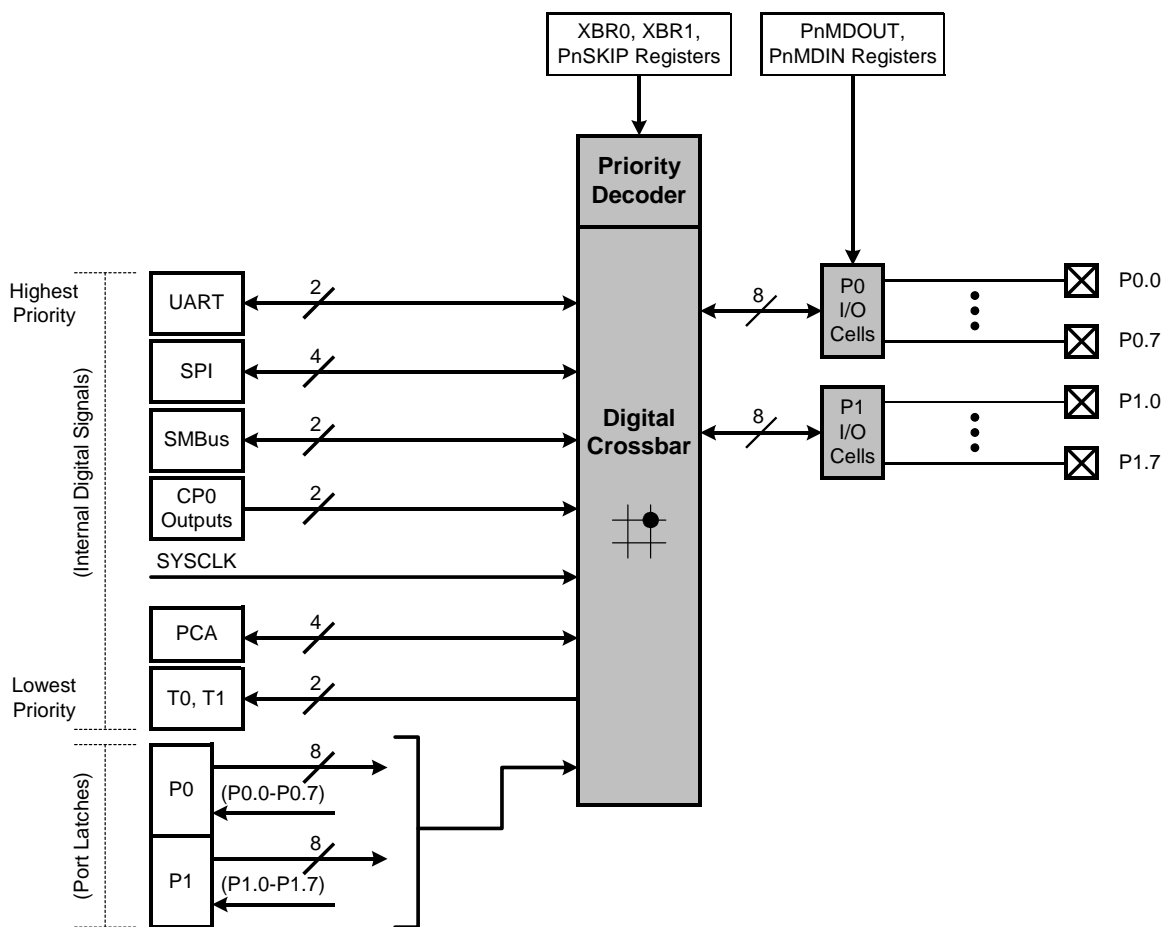

**Figure 14.1. Port I/O Functional Block Diagram**

# C8051F330/1/2/3/4/5

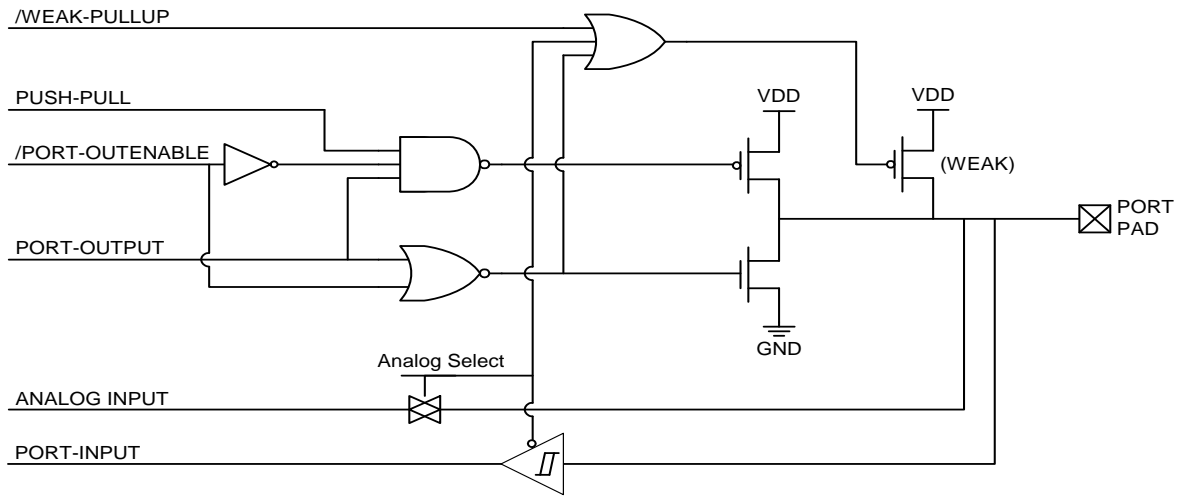

Figure 14.2. Port I/O Cell Block Diagram

## 14.1. Priority Crossbar Decoder

The Priority Crossbar Decoder (Figure 14.3) assigns a priority to each I/O function, starting at the top with UART0. When a digital resource is selected, the least-significant unassigned Port pin is assigned to that resource (excluding UART0, which is always at pins 4 and 5). If a Port pin is assigned, the Crossbar skips that pin when assigning the next selected resource. Additionally, the Crossbar will skip Port pins whose associated bits in the PnSKIP registers are set. The PnSKIP registers allow software to skip Port pins that are to be used for analog input, dedicated functions, or GPIO.

**Important Note on Crossbar Configuration:** If a Port pin is claimed by a peripheral without use of the Crossbar, its corresponding PnSKIP bit should be set. This applies to P0.0 if VREF is used, P0.3 and/or P0.2 if the external oscillator circuit is enabled, P0.6 if the ADC or IDAC is configured to use the external conversion start signal (CNVSTR), and any selected ADC or Comparator inputs. The Crossbar skips selected pins as if they were already assigned, and moves to the next unassigned pin. Figure 14.3 shows the Crossbar Decoder priority with no Port pins skipped (P0SKIP, P1SKIP = 0x00); Figure 14.4 shows the Crossbar Decoder priority with the XTAL1 (P0.2) and XTAL2 (P0.3) pins skipped (P0SKIP = 0x0C).

	P0								P1								P2	
SF Signals	VREF	IDA	x1	x2	CNVSTR													
PIN I/O	0	1	2	3	4	5	6	7	0	1	2	3	4	5	6	7	0	
TX0																		
RX0																		
SCK																		
MISO																		
MOSI																		
NSS*																		
SDA																		
SCL																		
CP0																		
CP0A																		
SYSCLK																		
CEX0																		
CEX1																		
CEX2																		
ECI																		
T0																		
T1																		
	0	0	0	0	0	0	0	0	0	0	0	0	0	0	0	0	0	
	P0SKIP[0:7]								P1SKIP[0:7]									



-  Port pin potentially available to peripheral
-  SF Signals Special Function Signals are not assigned by the crossbar. When these signals are enabled, the CrossBar must be manually configured to skip their corresponding port pins.

Figure 14.3. Crossbar Priority Decoder with No Pins Skipped

# C8051F330/1/2/3/4/5

	P0								P1								P2
SF Signals	VREF	IDA	x1	x2	CNVSTR												
PIN I/O	0	1	2	3	4	5	6	7	0	1	2	3	4	5	6	7	0
TX0																	
RX0																	
SCK																	
MISO																	
MOSI																	
NSS*																	
SDA																	
SCL																	
CP0																	
CP0A																	
SYSCLK																	
CEX0																	
CEX1																	
CEX2																	
ECI																	
T0																	
T1																	
	0	0	1	1	0	0	0	0	0	0	0	0	0	0	0	0	0
	P0SKIP[0:7]								P1SKIP[0:7]								

\*NSS is only pinned out in 4-wire SPI Mode



Port pin potentially available to peripheral

**SF Signals**

Special Function Signals are not assigned by the crossbar. When these signals are enabled, the CrossBar must be manually configured to skip their corresponding port pins.

**Figure 14.4. Crossbar Priority Decoder with Crystal Pins Skipped**

Registers XBR0 and XBR1 are used to assign the digital I/O resources to the physical I/O Port pins. Note that when the SMBus is selected, the Crossbar assigns both pins associated with the SMBus (SDA and SCL); when the UART is selected, the Crossbar assigns both pins associated with the UART (TX and RX). UART0 pin assignments are fixed for bootloading purposes: UART TX0 is always assigned to P0.4; UART RX0 is always assigned to P0.5. Standard Port I/Os appear contiguously after the prioritized functions have been assigned.

**Important Note:** The SPI can be operated in either 3-wire or 4-wire modes, pending the state of the NSS-MD1–NSSMD0 bits in register SPI0CN. According to the SPI mode, the NSS signal may or may not be routed to a Port pin.

---

## 14.2. Port I/O Initialization

Port I/O initialization consists of the following steps:

- Step 1. Select the input mode (analog or digital) for all Port pins, using the Port Input Mode register (PnMDIN).
- Step 2. Select the output mode (open-drain or push-pull) for all Port pins, using the Port Output Mode register (PnMDOUT).
- Step 3. Select any pins to be skipped by the I/O Crossbar using the Port Skip registers (PnSKIP).
- Step 4. Assign Port pins to desired peripherals.
- Step 5. Enable the Crossbar (XBARE = '1').

All Port pins must be configured as either analog or digital inputs. Any pins to be used as Comparator or ADC inputs should be configured as an analog inputs. When a pin is configured as an analog input, its weak pullup, digital driver, and digital receiver are disabled. This process saves power and reduces noise on the analog input. Pins configured as digital inputs may still be used by analog peripherals; however this practice is not recommended.

Additionally, all analog input pins should be configured to be skipped by the Crossbar (accomplished by setting the associated bits in PnSKIP). Port input mode is set in the PnMDIN register, where a '1' indicates a digital input, and a '0' indicates an analog input. All pins default to digital inputs on reset. See SFR Definition 14.4 for the PnMDIN register details.

The output driver characteristics of the I/O pins are defined using the Port Output Mode registers (PnMDOUT). Each Port Output driver can be configured as either open drain or push-pull. This selection is required even for the digital resources selected in the XBRn registers, and is not automatic. The only exception to this is the SMBus (SDA, SCL) pins, which are configured as open-drain regardless of the PnMDOUT settings. When the WEAKPUD bit in XBR1 is '0', a weak pullup is enabled for all Port I/O configured as open-drain. WEAKPUD does not affect the push-pull Port I/O. Furthermore, the weak pullup is turned off on an output that is driving a '0' to avoid unnecessary power dissipation.

Registers XBR0 and XBR1 must be loaded with the appropriate values to select the digital I/O functions required by the design. Setting the XBARE bit in XBR1 to '1' enables the Crossbar. Until the Crossbar is enabled, the external pins remain as standard Port I/O (in input mode), regardless of the XBRn Register settings. For given XBRn Register settings, one can determine the I/O pin-out using the Priority Decode Table; as an alternative, the Configuration Wizard utility of the Silicon Labs IDE software will determine the Port I/O pin-assignments based on the XBRn Register settings.

The Crossbar must be enabled to use Port pins as standard Port I/O in output mode. Port output drivers are disabled while the Crossbar is disabled.

# C8051F330/1/2/3/4/5

## SFR Definition 14.1. XBR0: Port I/O Crossbar Register 0

R	R	R/W	R/W	R/W	R/W	R/W	R/W	Reset Value
-	-	CP0AE	CP0E	SYSCKE	SMB0E	SPI0E	URT0E	00000000
Bit7	Bit6	Bit5	Bit4	Bit3	Bit2	Bit1	Bit0	SFR Address: 0xE1

Bits7–6: UNUSED. Read = 00b, Write = don't care.  
 Bit5: CP0AE: Comparator0 Asynchronous Output Enable  
 0: Asynchronous CP0 unavailable at Port pin.  
 1: Asynchronous CP0 routed to Port pin.  
 Bit4: CP0E: Comparator0 Output Enable  
 0: CP0 unavailable at Port pin.  
 1: CP0 routed to Port pin.  
 Bit3: SYSCKE: /SYSCLK Output Enable  
 0: /SYSCLK unavailable at Port pin.  
 1: /SYSCLK output routed to Port pin.  
 Bit2: SMB0E: SMBus I/O Enable  
 0: SMBus I/O unavailable at Port pins.  
 1: SMBus I/O routed to Port pins.  
 Bit1: SPI0E: SPI I/O Enable  
 0: SPI I/O unavailable at Port pins.  
 1: SPI I/O routed to Port pins. Note that the SPI can be assigned either 3 or 4 GPIO pins.  
 Bit0: URT0E: UART I/O Output Enable  
 0: UART I/O unavailable at Port pin.  
 1: UART TX0, RX0 routed to Port pins P0.4 and P0.5.



## SFR Definition 14.2. XBR1: Port I/O Crossbar Register 1

R/W	R/W	R/W	R/W	R/W	R	R/W	R/W	Reset Value
WEAKPUD	XBARE	T1E	T0E	ECIE	-	PCA0ME		00000000
Bit7	Bit6	Bit5	Bit4	Bit3	Bit2	Bit1	Bit0	SFR Address: 0xE2
<p>Bit7: WEAKPUD: Port I/O Weak Pullup Disable. 0: Weak Pullups enabled (except for Ports whose I/O are configured as analog input). 1: Weak Pullups disabled.</p> <p>Bit6: XBARE: Crossbar Enable. 0: Crossbar disabled. 1: Crossbar enabled.</p> <p>Bit5: T1E: T1 Enable 0: T1 unavailable at Port pin. 1: T1 routed to Port pin.</p> <p>Bit4: T0E: T0 Enable 0: T0 unavailable at Port pin. 1: T0 routed to Port pin.</p> <p>Bit3: ECIE: PCA0 External Counter Input Enable 0: ECI unavailable at Port pin. 1: ECI routed to Port pin.</p> <p>Bit2: Unused. Read = 0b. Write = don't care.</p> <p>Bits1–0: PCA0ME: PCA Module I/O Enable Bits. 00: All PCA I/O unavailable at Port pins. 01: CEX0 routed to Port pin. 10: CEX0, CEX1 routed to Port pins. 11: CEX0, CEX1, CEX2 routed to Port pins.</p>								

### 14.3. General Purpose Port I/O

Port pins that remain unassigned by the Crossbar and are not used by analog peripherals can be used for general purpose I/O. Ports2–0 are accessed through corresponding special function registers (SFRs) that are both byte addressable and bit addressable. When writing to a Port, the value written to the SFR is latched to maintain the output data value at each pin. When reading, the logic levels of the Port's input pins are returned regardless of the XBRn settings (i.e., even when the pin is assigned to another signal by the Crossbar, the Port register can always read its corresponding Port I/O pin). The exception to this is the execution of the read-modify-write instructions that target a Port Latch register as the destination. The read-modify-write instructions when operating on a Port SFR are the following: ANL, ORL, XRL, JBC, CPL, INC, DEC, DJNZ and MOV, CLR or SETB, when the destination is an individual bit in a Port SFR. For these instructions, the value of the register (not the pin) is read, modified, and written back to the SFR.

# C8051F330/1/2/3/4/5

## SFR Definition 14.3. P0: Port0

R/W	R/W	R/W	R/W	R/W	R/W	R/W	R/W	Reset Value
P0.7	P0.6	P0.5	P0.4	P0.3	P0.2	P0.1	P0.0	11111111
Bit7	Bit6	Bit5	Bit4	Bit3	Bit2	Bit1	Bit0	SFR Address: 0x80

(bit addressable)

Bits7–0: P0.[7:0]  
Write - Output appears on I/O pins per Crossbar Registers.  
0: Logic Low Output.  
1: Logic High Output (high impedance if corresponding P0MDOUT.n bit = 0).  
Read - Always reads '0' if selected as analog input in register P0MDIN. Directly reads Port pin when configured as digital input.  
0: P0.n pin is logic low.  
1: P0.n pin is logic high.

## SFR Definition 14.4. P0MDIN: Port0 Input Mode

R/W	R/W	R/W	R/W	R/W	R/W	R/W	R/W	Reset Value
								11111111
Bit7	Bit6	Bit5	Bit4	Bit3	Bit2	Bit1	Bit0	SFR Address: 0xF1

Bits7–0: Analog Input Configuration Bits for P0.7–P0.0 (respectively).  
Port pins configured as analog inputs have their weak pullup, digital driver, and digital receiver disabled.  
0: Corresponding P0.n pin is configured as an analog input.  
1: Corresponding P0.n pin is not configured as an analog input.

## SFR Definition 14.5. P0MDOUT: Port0 Output Mode

R/W	R/W	R/W	R/W	R/W	R/W	R/W	R/W	Reset Value
								00000000
Bit7	Bit6	Bit5	Bit4	Bit3	Bit2	Bit1	Bit0	SFR Address: 0xA4

Bits7–0: Output Configuration Bits for P0.7–P0.0 (respectively): ignored if corresponding bit in register P0MDIN is logic 0.  
 0: Corresponding P0.n Output is open-drain.  
 1: Corresponding P0.n Output is push-pull.

(Note: When SDA and SCL appear on any of the Port I/O, each are open-drain regardless of the value of P0MDOUT).

## SFR Definition 14.6. P0SKIP: Port0 Skip

R/W	R/W	R/W	R/W	R/W	R/W	R/W	R/W	Reset Value
								00000000
Bit7	Bit6	Bit5	Bit4	Bit3	Bit2	Bit1	Bit0	SFR Address: 0xD4

Bits7–0: P0SKIP[7:0]: Port0 Crossbar Skip Enable Bits.  
 These bits select Port pins to be skipped by the Crossbar Decoder. Port pins used as analog inputs (for ADC or Comparator) or used as special functions (VREF input, external oscillator circuit, CNVSTR input) should be skipped by the Crossbar.  
 0: Corresponding P0.n pin is not skipped by the Crossbar.  
 1: Corresponding P0.n pin is skipped by the Crossbar.

## SFR Definition 14.7. P1: Port1

R/W	R/W	R/W	R/W	R/W	R/W	R/W	R/W	Reset Value
P1.7	P1.6	P1.5	P1.4	P1.3	P1.2	P1.1	P1.0	11111111
Bit7	Bit6	Bit5	Bit4	Bit3	Bit2	Bit1	Bit0	SFR Address: (bit addressable) 0x90

Bits7–0: P1.[7:0]  
 Write - Output appears on I/O pins per Crossbar Registers.  
 0: Logic Low Output.  
 1: Logic High Output (high impedance if corresponding P1MDOUT.n bit = 0).  
 Read - Always reads '0' if selected as analog input in register P1MDIN. Directly reads Port pin when configured as digital input.  
 0: P1.n pin is logic low.  
 1: P1.n pin is logic high.

# C8051F330/1/2/3/4/5

## SFR Definition 14.8. P1MDIN: Port1 Input Mode

R/W	R/W	R/W	R/W	R/W	R/W	R/W	R/W	Reset Value
								11111111
Bit7	Bit6	Bit5	Bit4	Bit3	Bit2	Bit1	Bit0	SFR Address: 0xF2

Bits7–0: Analog Input Configuration Bits for P1.7–P1.0 (respectively).  
Port pins configured as analog inputs have their weak pullup, digital driver, and digital receiver disabled.  
0: Corresponding P1.n pin is configured as an analog input.  
1: Corresponding P1.n pin is not configured as an analog input.

## SFR Definition 14.9. P1MDOUT: Port1 Output Mode

R/W	R/W	R/W	R/W	R/W	R/W	R/W	R/W	Reset Value
								00000000
Bit7	Bit6	Bit5	Bit4	Bit3	Bit2	Bit1	Bit0	SFR Address: 0xA5

Bits7–0: Output Configuration Bits for P1.7–P1.0 (respectively): ignored if corresponding bit in register P1MDIN is logic 0.  
0: Corresponding P1.n Output is open-drain.  
1: Corresponding P1.n Output is push-pull.

## SFR Definition 14.10. P1SKIP: Port1 Skip

R/W	R/W	R/W	R/W	R/W	R/W	R/W	R/W	Reset Value
-								00000000
Bit7	Bit6	Bit5	Bit4	Bit3	Bit2	Bit1	Bit0	SFR Address: 0xD5

Bit7: UNUSED: Read = 0b; Write = don't care.  
Bits6–0: P1SKIP[6:0]: Port1 Crossbar Skip Enable Bits.  
These bits select Port pins to be skipped by the Crossbar Decoder. Port pins used as analog inputs (for ADC or Comparator) or used as special functions (VREF input, external oscillator circuit, CNVSTR input) should be skipped by the Crossbar.  
0: Corresponding P1.n pin is not skipped by the Crossbar.  
1: Corresponding P1.n pin is skipped by the Crossbar.

## SFR Definition 14.11. P2: Port2

R	R	R	R	R	R	R	R/W	Reset Value
-	-	-	-	-	-	-	P2.0	00000001
Bit7	Bit6	Bit5	Bit4	Bit3	Bit2	Bit1	Bit0 (bit addressable)	SFR Address: 0xA0

Bits7–1: Unused. Read = 0000000b. Write = don't care.  
 Bit0: P2.0  
 Write - Output appears on I/O pins per Crossbar Registers.  
 0: Logic Low Output.  
 1: Logic High Output (high impedance if corresponding P2MDOUT.n bit = 0).  
 Read - Directly reads Port pin.  
 0: P2.n pin is logic low.  
 1: P2.n pin is logic high.

## SFR Definition 14.12. P2MDOUT: Port2 Output Mode

R	R	R	R	R	R	R	R/W	Reset Value
-	-	-	-	-	-	-		00000000
Bit7	Bit6	Bit5	Bit4	Bit3	Bit2	Bit1	Bit0	SFR Address: 0xA6

Bits7–1: Unused. Read = 0000000b. Write = don't care.  
 Bit0: Output Configuration Bit for P2.0.  
 0: P2.0 Output is open-drain.  
 1: P2.0 Output is push-pull.

# C8051F330/1/2/3/4/5

**Table 14.1. Port I/O DC Electrical Characteristics**

$V_{DD}$  = 2.7 to 3.6 V, -40 to +85 °C unless otherwise specified.

Parameters	Conditions	Min	Typ	Max	Units
Output High Voltage	$I_{OH} = -3$ mA, Port I/O push-pull	$V_{DD} - 0.7$	—	—	V
	$I_{OH} = -10$ $\mu$ A, Port I/O push-pull	$V_{DD} - 0.1$	—	—	
	$I_{OH} = -10$ mA, Port I/O push-pull	—	$V_{DD} - 0.8$	—	
Output Low Voltage	$I_{OL} = 8.5$ mA	—	—	0.6	V
	$I_{OL} = 10$ $\mu$ A	—	—	0.1	
	$I_{OL} = 25$ mA	—	1.0	—	
Input High Voltage		2.0	—	—	V
Input Low Voltage		—	—	0.8	V
Input Leakage Current	Weak Pullup Off	—	—	$\pm 1$	$\mu$ A
	Weak Pullup On, $V_{IN} = 0$ V	—	25	50	



# C8051F330/1/2/3/4/5

## 15.1. Supporting Documents

It is assumed the reader is familiar with or has access to the following supporting documents:

1. The I2C-Bus and How to Use It (including specifications), Philips Semiconductor.
2. The I2C-Bus Specification—Version 2.0, Philips Semiconductor.
3. System Management Bus Specification—Version 1.1, SBS Implementers Forum.

## 15.2. SMBus Configuration

Figure 15.2 shows a typical SMBus configuration. The SMBus specification allows any recessive voltage between 3.0 V and 5.0 V; different devices on the bus may operate at different voltage levels. The bi-directional SCL (serial clock) and SDA (serial data) lines must be connected to a positive power supply voltage through a pullup resistor or similar circuit. Every device connected to the bus must have an open-drain or open-collector output for both the SCL and SDA lines, so that both are pulled high (recessive state) when the bus is free. The maximum number of devices on the bus is limited only by the requirement that the rise and fall times on the bus not exceed 300 ns and 1000 ns, respectively.

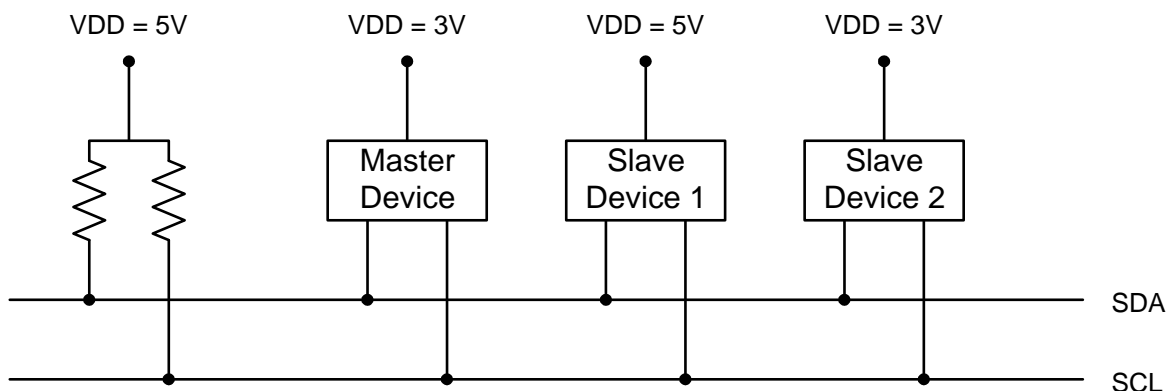

Figure 15.2. Typical SMBus Configuration

## 15.3. SMBus Operation

Two types of data transfers are possible: data transfers from a master transmitter to an addressed slave receiver (WRITE), and data transfers from an addressed slave transmitter to a master receiver (READ). The master device initiates both types of data transfers and provides the serial clock pulses on SCL. The SMBus interface may operate as a master or a slave, and multiple master devices on the same bus are supported. If two or more masters attempt to initiate a data transfer simultaneously, an arbitration scheme is employed with a single master always winning the arbitration. Note that it is not necessary to specify one device as the Master in a system; any device who transmits a START and a slave address becomes the master for the duration of that transfer.

A typical SMBus transaction consists of a START condition followed by an address byte (Bits7–1: 7-bit slave address; Bit0: R/W direction bit), one or more bytes of data, and a STOP condition. Each byte that is received (by a master or slave) must be acknowledged (ACK) with a low SDA during a high SCL (see Figure 15.3). If the receiving device does not ACK, the transmitting device will read a NACK (not acknowledge), which is a high SDA during a high SCL.



The direction bit (R/W) occupies the least-significant bit position of the address byte. The direction bit is set to logic 1 to indicate a "READ" operation and cleared to logic 0 to indicate a "WRITE" operation.

All transactions are initiated by a master, with one or more addressed slave devices as the target. The master generates the START condition and then transmits the slave address and direction bit. If the transaction is a WRITE operation from the master to the slave, the master transmits the data a byte at a time waiting for an ACK from the slave at the end of each byte. For READ operations, the slave transmits the data waiting for an ACK from the master at the end of each byte. At the end of the data transfer, the master generates a STOP condition to terminate the transaction and free the bus. Figure 15.3 illustrates a typical SMBus transaction.

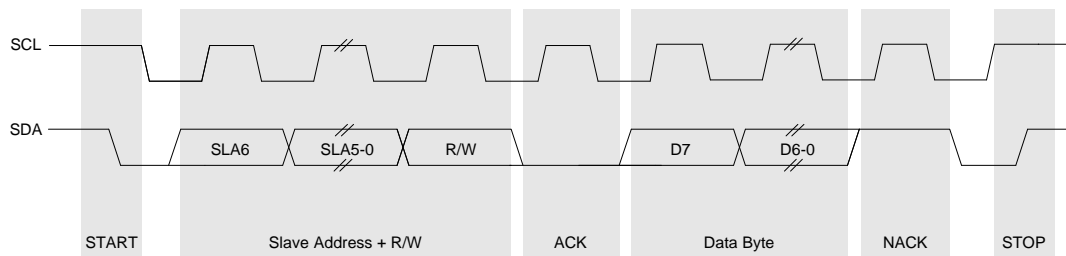

**Figure 15.3. SMBus Transaction**

### 15.3.1. Arbitration

A master may start a transfer only if the bus is free. The bus is free after a STOP condition or after the SCL and SDA lines remain high for a specified time (see [Section "15.3.4. SCL High \(SMBus Free\) Timeout" on page 138](#)). In the event that two or more devices attempt to begin a transfer at the same time, an arbitration scheme is employed to force one master to give up the bus. The master devices continue transmitting until one attempts a HIGH while the other transmits a LOW. Since the bus is open-drain, the bus will be pulled LOW. The master attempting the HIGH will detect a LOW SDA and lose the arbitration. The winning master continues its transmission without interruption; the losing master becomes a slave and receives the rest of the transfer if addressed. This arbitration scheme is non-destructive: one device always wins, and no data is lost.

## 15.3.2. Clock Low Extension

SMBus provides a clock synchronization mechanism, similar to I2C, which allows devices with different speed capabilities to coexist on the bus. A clock-low extension is used during a transfer in order to allow slower slave devices to communicate with faster masters. The slave may temporarily hold the SCL line LOW to extend the clock low period, effectively decreasing the serial clock frequency.

## 15.3.3. SCL Low Timeout

If the SCL line is held low by a slave device on the bus, no further communication is possible. Furthermore, the master cannot force the SCL line high to correct the error condition. To solve this problem, the SMBus protocol specifies that devices participating in a transfer must detect any clock cycle held low longer than 25 ms as a “timeout” condition. Devices that have detected the timeout condition must reset the communication no later than 10 ms after detecting the timeout condition.

When the SMBTOE bit in SMB0CF is set, Timer 3 is used to detect SCL low timeouts. Timer 3 is forced to reload when SCL is high, and allowed to count when SCL is low. With Timer 3 enabled and configured to overflow after 25 ms (and SMBTOE set), the Timer 3 interrupt service routine can be used to reset (disable and re-enable) the SMBus in the event of an SCL low timeout.

## 15.3.4. SCL High (SMBus Free) Timeout

The SMBus specification stipulates that if the SCL and SDA lines remain high for more than 50  $\mu$ s, the bus is designated as free. When the SMBFTE bit in SMB0CF is set, the bus will be considered free if SCL and SDA remain high for more than 10 SMBus clock source periods. If the SMBus is waiting to generate a Master START, the START will be generated following this timeout. Note that a clock source is required for free timeout detection, even in a slave-only implementation.

## 15.4. Using the SMBus

The SMBus can operate in both Master and Slave modes. The interface provides timing and shifting control for serial transfers; higher level protocol is determined by user software. The SMBus interface provides the following application-independent features:

- Byte-wise serial data transfers
- Clock signal generation on SCL (Master Mode only) and SDA data synchronization
- Timeout/bus error recognition, as defined by the SMB0CF configuration register
- START/STOP timing, detection, and generation
- Bus arbitration
- Interrupt generation
- Status information

SMBus interrupts are generated for each data byte or slave address that is transferred. When transmitting, this interrupt is generated after the ACK cycle so that software may read the received ACK value; when receiving data, this interrupt is generated before the ACK cycle so that software may define the outgoing ACK value. See [Section “15.5. SMBus Transfer Modes” on page 146](#) for more details on transmission sequences.

Interrupts are also generated to indicate the beginning of a transfer when a master (START generated), or the end of a transfer when a slave (STOP detected). Software should read the SMB0CN (SMBus Control register) to find the cause of the SMBus interrupt. The SMB0CN register is described in [Section “15.4.2. SMB0CN Control Register” on page 143](#); Table 15.4 provides a quick SMB0CN decoding reference.

SMBus configuration options include:

- Timeout detection (SCL Low Timeout and/or Bus Free Timeout)
- SDA setup and hold time extensions
- Slave event enable/disable
- Clock source selection

These options are selected in the SMB0CF register, as described in [Section “15.4.1. SMBus Configuration Register” on page 140](#).

## 15.4.1. SMBus Configuration Register

The SMBus Configuration register (SMB0CF) is used to enable the SMBus Master and/or Slave modes, select the SMBus clock source, and select the SMBus timing and timeout options. When the ENSMB bit is set, the SMBus is enabled for all master and slave events. Slave events may be disabled by setting the INH bit. With slave events inhibited, the SMBus interface will still monitor the SCL and SDA pins; however, the interface will NACK all received addresses and will not generate any slave interrupts. When the INH bit is set, all slave events will be inhibited following the next START (interrupts will continue for the duration of the current transfer).

**Table 15.1. SMBus Clock Source Selection**

SMBCS1	SMBCS0	SMBus Clock Source
0	0	Timer 0 Overflow
0	1	Timer 1 Overflow
1	0	Timer 2 High Byte Overflow
1	1	Timer 2 Low Byte Overflow

The SMBCS1–0 bits select the SMBus clock source, which is used only when operating as a master or when the Free Timeout detection is enabled. When operating as a master, overflows from the selected source determine the absolute minimum SCL low and high times as defined in Equation 15.1. Note that the selected clock source may be shared by other peripherals so long as the timer is left running at all times. For example, Timer 1 overflows may generate the SMBus and UART baud rates simultaneously. Timer configuration is covered in [Section “18. Timers” on page 177](#).

$$T_{HighMin} = T_{LowMin} = \frac{1}{f_{ClockSourceOverflow}}$$

### Equation 15.1. Minimum SCL High and Low Times

The selected clock source should be configured to establish the minimum SCL High and Low times as per Equation 15.1. When the interface is operating as a master (and SCL is not driven or extended by any other devices on the bus), the typical SMBus bit rate is approximated by Equation 15.2.

$$BitRate = \frac{f_{ClockSourceOverflow}}{3}$$

### Equation 15.2. Typical SMBus Bit Rate

Figure 15.4 shows the typical SCL generation described by Equation 15.2. Notice that  $T_{HIGH}$  is typically twice as large as  $T_{LOW}$ . The actual SCL output may vary due to other devices on the bus (SCL may be extended low by slower slave devices, or driven low by contending master devices). The bit rate when operating as a master will never exceed the limits defined by equation Equation 15.1.

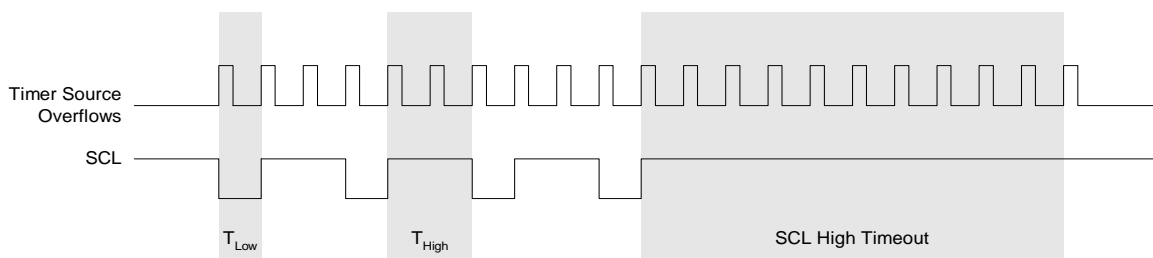

**Figure 15.4. Typical SMBus SCL Generation**

Setting the EXTHOLD bit extends the minimum setup and hold times for the SDA line. The minimum SDA setup time defines the absolute minimum time that SDA is stable before SCL transitions from low-to-high. The minimum SDA hold time defines the absolute minimum time that the current SDA value remains stable after SCL transitions from high-to-low. EXTHOLD should be set so that the minimum setup and hold times meet the SMBus Specification requirements of 250 ns and 300 ns, respectively. Table 15.2 shows the minimum setup and hold times for the two EXTHOLD settings. Setup and hold time extensions are typically necessary when SYSCLK is above 10 MHz.

**Table 15.2. Minimum SDA Setup and Hold Times**

EXTHOLD	Minimum SDA Setup Time	Minimum SDA Hold Time
0	$T_{low} - 4$ system clocks or 1 system clock + s/w delay*	3 system clocks
1	11 system clocks	12 system clocks

**\*Note:** Setup Time for ACK bit transmissions and the MSB of all data transfers. The s/w delay occurs between the time SMB0DAT or ACK is written and when SI is cleared. Note that if SI is cleared in the same write that defines the outgoing ACK value, s/w delay is zero.

With the SMBTOE bit set, Timer 3 should be configured to overflow after 25 ms in order to detect SCL low timeouts (see [Section “15.3.3. SCL Low Timeout” on page 138](#)). The SMBus interface will force Timer 3 to reload while SCL is high, and allow Timer 3 to count when SCL is low. The Timer 3 interrupt service routine should be used to reset SMBus communication by disabling and re-enabling the SMBus.

SMBus Free Timeout detection can be enabled by setting the SMBFTE bit. When this bit is set, the bus will be considered free if SDA and SCL remain high for more than 10 SMBus clock source periods (see Figure 15.4). When a Free Timeout is detected, the interface will respond as if a STOP was detected (an interrupt will be generated, and STO will be set).

# C8051F330/1/2/3/4/5

## SFR Definition 15.1. SMB0CF: SMBus Clock/Configuration

R/W	R/W	R	R/W	R/W	R/W	R/W	R/W	Reset Value
ENSMB	INH	BUSY	EXTHOLD	SMBTOE	SMBFTE	SMBCS1	SMBCS0	00000000
Bit7	Bit6	Bit5	Bit4	Bit3	Bit2	Bit1	Bit0	

SFR Address: 0xC1

- Bit7:** ENSMB: SMBus Enable.  
This bit enables/disables the SMBus interface. When enabled, the interface constantly monitors the SDA and SCL pins.  
0: SMBus interface disabled.  
1: SMBus interface enabled.
- Bit6:** INH: SMBus Slave Inhibit.  
When this bit is set to logic 1, the SMBus does not generate an interrupt when slave events occur. This effectively removes the SMBus slave from the bus. Master Mode interrupts are not affected.  
0: SMBus Slave Mode enabled.  
1: SMBus Slave Mode inhibited.
- Bit5:** BUSY: SMBus Busy Indicator.  
This bit is set to logic 1 by hardware when a transfer is in progress. It is cleared to logic 0 when a STOP or free-timeout is sensed.
- Bit4:** EXTHOLD: SMBus Setup and Hold Time Extension Enable.  
This bit controls the SDA setup and hold times according to .  
0: SDA Extended Setup and Hold Times disabled.  
1: SDA Extended Setup and Hold Times enabled.
- Bit3:** SMBTOE: SMBus SCL Timeout Detection Enable.  
This bit enables SCL low timeout detection. If set to logic 1, the SMBus forces Timer 3 to reload while SCL is high and allows Timer 3 to count when SCL goes low. If Timer 3 is configured to Split Mode, only the High Byte of the timer is held in reload while SCL is high. Timer 3 should be programmed to generate interrupts at 25 ms, and the Timer 3 interrupt service routine should reset SMBus communication.
- Bit2:** SMBFTE: SMBus Free Timeout Detection Enable.  
When this bit is set to logic 1, the bus will be considered free if SCL and SDA remain high for more than 10 SMBus clock source periods.
- Bits1–0:** SMBCS1–SMBCS0: SMBus Clock Source Selection.  
These two bits select the SMBus clock source, which is used to generate the SMBus bit rate. The selected device should be configured according to Equation 15.1.

SMBCS1	SMBCS0	SMBus Clock Source
0	0	Timer 0 Overflow
0	1	Timer 1 Overflow
1	0	Timer 2 High Byte Overflow
1	1	Timer 2 Low Byte Overflow

---

## 15.4.2. SMB0CN Control Register

SMB0CN is used to control the interface and to provide status information (see SFR Definition 15.2). The higher four bits of SMB0CN (MASTER, TXMODE, STA, and STO) form a status vector that can be used to jump to service routines. MASTER and TXMODE indicate the master/slave state and transmit/receive modes, respectively.

STA and STO indicate that a START and/or STOP has been detected or generated since the last SMBus interrupt. STA and STO are also used to generate START and STOP conditions when operating as a master. Writing a '1' to STA will cause the SMBus interface to enter Master Mode and generate a START when the bus becomes free (STA is not cleared by hardware after the START is generated). Writing a '1' to STO while in Master Mode will cause the interface to generate a STOP and end the current transfer after the next ACK cycle. If STO and STA are both set (while in Master Mode), a STOP followed by a START will be generated.

As a receiver, writing the ACK bit defines the outgoing ACK value; as a transmitter, reading the ACK bit indicates the value received on the last ACK cycle. ACKRQ is set each time a byte is received, indicating that an outgoing ACK value is needed. When ACKRQ is set, software should write the desired outgoing value to the ACK bit before clearing SI. A NACK will be generated if software does not write the ACK bit before clearing SI. SDA will reflect the defined ACK value immediately following a write to the ACK bit; however SCL will remain low until SI is cleared. If a received slave address is not acknowledged, further slave events will be ignored until the next START is detected.

The ARBLOST bit indicates that the interface has lost an arbitration. This may occur anytime the interface is transmitting (master or slave). A lost arbitration while operating as a slave indicates a bus error condition. ARBLOST is cleared by hardware each time SI is cleared.

The SI bit (SMBus Interrupt Flag) is set at the beginning and end of each transfer, after each byte frame, or when an arbitration is lost; see Table 15.3 for more details.

**Important Note About the SI Bit:** The SMBus interface is stalled while SI is set; thus SCL is held low, and the bus is stalled until software clears SI.

Table 15.3 lists all sources for hardware changes to the SMB0CN bits. Refer to Table 15.4 for SMBus status decoding using the SMB0CN register.

# C8051F330/1/2/3/4/5

## SFR Definition 15.2. SMB0CN: SMBus Control

R	R	R/W	R/W	R	R	R/W	R/W	Reset Value
MASTER	TXMODE	STA	STO	ACKRQ	ARBLOST	ACK	SI	00000000
Bit7	Bit6	Bit5	Bit4	Bit3	Bit2	Bit1	Bit0	Bit Addressable
SFR Address: 0xC0								
Bit7:	<p><b>MASTER: SMBus Master/Slave Indicator.</b>            This read-only bit indicates when the SMBus is operating as a master.            0: SMBus operating in Slave Mode.            1: SMBus operating in Master Mode.</p>							
Bit6:	<p><b>TXMODE: SMBus Transmit Mode Indicator.</b>            This read-only bit indicates when the SMBus is operating as a transmitter.            0: SMBus in Receiver Mode.            1: SMBus in Transmitter Mode.</p>							
Bit5:	<p><b>STA: SMBus Start Flag.</b>            Write:            0: No Start generated.            1: When operating as a master, a START condition is transmitted if the bus is free (If the bus is not free, the START is transmitted after a STOP is received or a timeout is detected). If STA is set by software as an active Master, a repeated START will be generated after the next ACK cycle.            Read:            0: No Start or repeated Start detected.            1: Start or repeated Start detected.</p>							
Bit4:	<p><b>STO: SMBus Stop Flag.</b>            Write:            0: No STOP condition is transmitted.            1: Setting STO to logic 1 causes a STOP condition to be transmitted after the next ACK cycle. When the STOP condition is generated, hardware clears STO to logic 0. If both STA and STO are set, a STOP condition is transmitted followed by a START condition.            Read:            0: No Stop condition detected.            1: Stop condition detected (if in Slave Mode) or pending (if in Master Mode).</p>							
Bit3:	<p><b>ACKRQ: SMBus Acknowledge Request</b>            This read-only bit is set to logic 1 when the SMBus has received a byte and needs the ACK bit to be written with the correct ACK response value.</p>							
Bit2:	<p><b>ARBLOST: SMBus Arbitration Lost Indicator.</b>            This read-only bit is set to logic 1 when the SMBus loses arbitration while operating as a transmitter. A lost arbitration while a slave indicates a bus error condition.</p>							
Bit1:	<p><b>ACK: SMBus Acknowledge Flag.</b>            This bit defines the out-going ACK level and records incoming ACK levels. It should be written each time a byte is received (when ACKRQ=1), or read after each byte is transmitted.            0: A "not acknowledge" has been received (if in Transmitter Mode) OR will be transmitted (if in Receiver Mode).            1: An "acknowledge" has been received (if in Transmitter Mode) OR will be transmitted (if in Receiver Mode).</p>							
Bit0:	<p><b>SI: SMBus Interrupt Flag.</b>            This bit is set by hardware under the conditions listed in Table 15.3. SI must be cleared by software. While SI is set, SCL is held low and the SMBus is stalled.</p>							



**Table 15.3. Sources for Hardware Changes to SMB0CN**

Bit	Set by Hardware When:	Cleared by Hardware When:
MASTER	<ul style="list-style-type: none"> <li>• A START is generated.</li> </ul>	<ul style="list-style-type: none"> <li>• A STOP is generated.</li> <li>• Arbitration is lost.</li> </ul>
TXMODE	<ul style="list-style-type: none"> <li>• START is generated.</li> <li>• SMB0DAT is written before the start of an SMBus frame.</li> </ul>	<ul style="list-style-type: none"> <li>• A START is detected.</li> <li>• Arbitration is lost.</li> <li>• SMB0DAT is not written before the start of an SMBus frame.</li> </ul>
STA	<ul style="list-style-type: none"> <li>• A START followed by an address byte is received.</li> </ul>	<ul style="list-style-type: none"> <li>• Must be cleared by software.</li> </ul>
STO	<ul style="list-style-type: none"> <li>• A STOP is detected while addressed as a slave.</li> <li>• Arbitration is lost due to a detected STOP.</li> </ul>	<ul style="list-style-type: none"> <li>• A pending STOP is generated.</li> </ul>
ACKRQ	<ul style="list-style-type: none"> <li>• A byte has been received and an ACK response value is needed.</li> </ul>	<ul style="list-style-type: none"> <li>• After each ACK cycle.</li> </ul>
ARBLOST	<ul style="list-style-type: none"> <li>• A repeated START is detected as a MASTER when STA is low (unwanted repeated START).</li> <li>• SCL is sensed low while attempting to generate a STOP or repeated START condition.</li> <li>• SDA is sensed low while transmitting a '1' (excluding ACK bits).</li> </ul>	<ul style="list-style-type: none"> <li>• Each time SI is cleared.</li> </ul>
ACK	<ul style="list-style-type: none"> <li>• The incoming ACK value is low (ACKNOWLEDGE).</li> </ul>	<ul style="list-style-type: none"> <li>• The incoming ACK value is high (NOT ACKNOWLEDGE).</li> </ul>
SI	<ul style="list-style-type: none"> <li>• A START has been generated.</li> <li>• Lost arbitration.</li> <li>• A byte has been transmitted and an ACK/NACK received.</li> <li>• A byte has been received.</li> <li>• A START or repeated START followed by a slave address + R/W has been received.</li> <li>• A STOP has been received.</li> </ul>	<ul style="list-style-type: none"> <li>• Must be cleared by software.</li> </ul>

# C8051F330/1/2/3/4/5

## 15.4.3. Data Register

The SMBus Data register SMB0DAT holds a byte of serial data to be transmitted or one that has just been received. Software may safely read or write to the data register when the SI flag is set. Software should not attempt to access the SMB0DAT register when the SMBus is enabled and the SI flag is cleared to logic 0, as the interface may be in the process of shifting a byte of data into or out of the register.

Data in SMB0DAT is always shifted out MSB first. After a byte has been received, the first bit of received data is located at the MSB of SMB0DAT. While data is being shifted out, data on the bus is simultaneously being shifted in. SMB0DAT always contains the last data byte present on the bus. In the event of lost arbitration, the transition from master transmitter to slave receiver is made with the correct data or address in SMB0DAT.

### SFR Definition 15.3. SMB0DAT: SMBus Data

R/W	R/W	R/W	R/W	R/W	R/W	R/W	R/W	Reset Value
								00000000
Bit7	Bit6	Bit5	Bit4	Bit3	Bit2	Bit1	Bit0	

SFR Address: 0xC2

Bits7–0: SMB0DAT: SMBus Data.  
The SMB0DAT register contains a byte of data to be transmitted on the SMBus serial interface or a byte that has just been received on the SMBus serial interface. The CPU can read from or write to this register whenever the SI serial interrupt flag (SMB0CN.0) is set to logic 1. The serial data in the register remains stable as long as the SI flag is set. When the SI flag is not set, the system may be in the process of shifting data in/out and the CPU should not attempt to access this register.

## 15.5. SMBus Transfer Modes

The SMBus interface may be configured to operate as master and/or slave. At any particular time, it will be operating in one of the following four modes: Master Transmitter, Master Receiver, Slave Transmitter, or Slave Receiver. The SMBus interface enters Master Mode any time a START is generated, and remains in Master Mode until it loses an arbitration or generates a STOP. An SMBus interrupt is generated at the end of all SMBus byte frames; however, note that the interrupt is generated before the ACK cycle when operating as a receiver, and after the ACK cycle when operating as a transmitter.

### 15.5.1. Master Transmitter Mode

Serial data is transmitted on SDA while the serial clock is output on SCL. The SMBus interface generates the START condition and transmits the first byte containing the address of the target slave and the data direction bit. In this case the data direction bit (R/W) will be logic 0 (WRITE). The master then transmits one or more bytes of serial data. After each byte is transmitted, an acknowledge bit is generated by the slave. The transfer is ended when the STO bit is set and a STOP is generated. Note that the interface will switch to Master Receiver Mode if SMB0DAT is not written following a Master Transmitter interrupt. Figure 15.5 shows a typical Master Transmitter sequence. Two transmit data bytes are shown, though any number of bytes may be transmitted. Notice that the 'data byte transferred' interrupts occur **after** the ACK cycle in this mode.

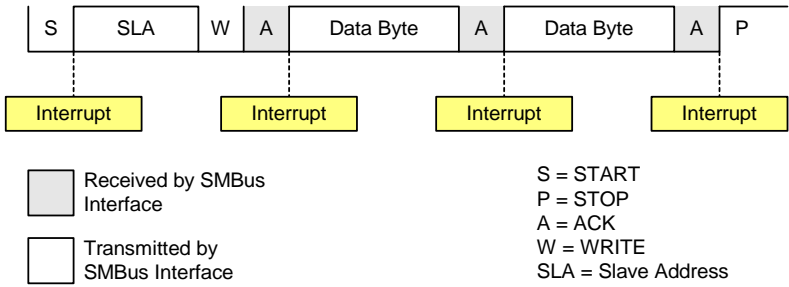
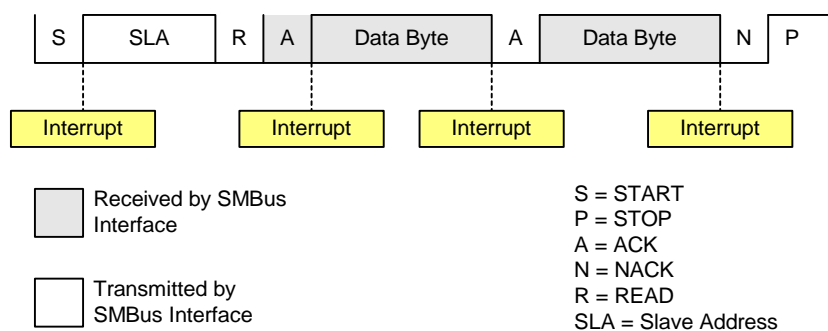

**Figure 15.5. Typical Master Transmitter Sequence**

# C8051F330/1/2/3/4/5

## 15.5.2. Master Receiver Mode

Serial data is received on SDA while the serial clock is output on SCL. The SMBus interface generates the START condition and transmits the first byte containing the address of the target slave and the data direction bit. In this case the data direction bit (R/W) will be logic 1 (READ). Serial data is then received from the slave on SDA while the SMBus outputs the serial clock. The slave transmits one or more bytes of serial data. After each byte is received, ACKRQ is set to '1' and an interrupt is generated. Software must write the ACK bit (SMB0CN.1) to define the outgoing acknowledge value (Note: writing a '1' to the ACK bit generates an ACK; writing a '0' generates a NACK). Software should write a '0' to the ACK bit after the last byte is received, to transmit a NACK. The interface exits Master Receiver Mode after the STO bit is set and a STOP is generated. The interface will switch to Master Transmitter Mode if SMB0DAT is written while an active Master Receiver. Figure 15.6 shows a typical Master Receiver sequence. Two received data bytes are shown, though any number of bytes may be received. Notice that the 'data byte transferred' interrupts occur **before** the ACK cycle in this mode.



**Figure 15.6. Typical Master Receiver Sequence**

### 15.5.3. Slave Receiver Mode

Serial data is received on SDA and the clock is received on SCL. When slave events are enabled (INH = 0), the interface enters Slave Receiver Mode when a START followed by a slave address and direction bit (WRITE in this case) is received. Upon entering Slave Receiver Mode, an interrupt is generated and the ACKRQ bit is set. Software responds to the received slave address with an ACK, or ignores the received slave address with a NACK. If the received slave address is ignored, slave interrupts will be inhibited until the next START is detected. If the received slave address is acknowledged, zero or more data bytes are received. Software must write the ACK bit after each received byte to ACK or NACK the received byte. The interface exits Slave Receiver Mode after receiving a STOP. Note that the interface will switch to Slave Transmitter Mode if SMB0DAT is written while an active Slave Receiver. Figure 15.7 shows a typical Slave Receiver sequence. Two received data bytes are shown, though any number of bytes may be received. Notice that the 'data byte transferred' interrupts occur **before** the ACK cycle in this mode.

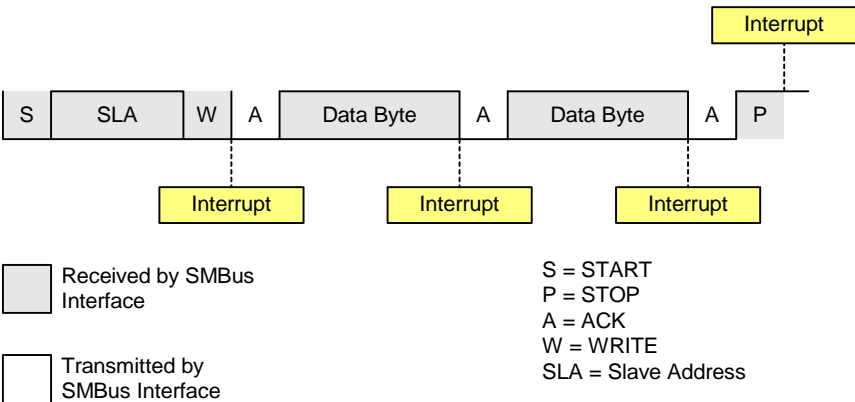

Figure 15.7. Typical Slave Receiver Sequence

# C8051F330/1/2/3/4/5

## 15.5.4. Slave Transmitter Mode

Serial data is transmitted on SDA and the clock is received on SCL. When slave events are enabled (INH = 0), the interface enters Slave Receiver Mode (to receive the slave address) when a START followed by a slave address and direction bit (READ in this case) is received. Upon entering Slave Transmitter Mode, an interrupt is generated and the ACKRQ bit is set. Software responds to the received slave address with an ACK, or ignores the received slave address with a NACK. If the received slave address is ignored, slave interrupts will be inhibited until a START is detected. If the received slave address is acknowledged, data should be written to SMBODAT to be transmitted. The interface enters Slave Transmitter Mode, and transmits one or more bytes of data. After each byte is transmitted, the master sends an acknowledge bit; if the acknowledge bit is an ACK, SMBODAT should be written with the next data byte. If the acknowledge bit is a NACK, SMBODAT should not be written to before SI is cleared (Note: an error condition may be generated if SMBODAT is written following a received NACK while in Slave Transmitter Mode). The interface exits Slave Transmitter Mode after receiving a STOP. Note that the interface will switch to Slave Receiver Mode if SMBODAT is not written following a Slave Transmitter interrupt. Figure 15.8 shows a typical Slave Transmitter sequence. Two transmitted data bytes are shown, though any number of bytes may be transmitted. Notice that the 'data byte transferred' interrupts occur **after** the ACK cycle in this mode.

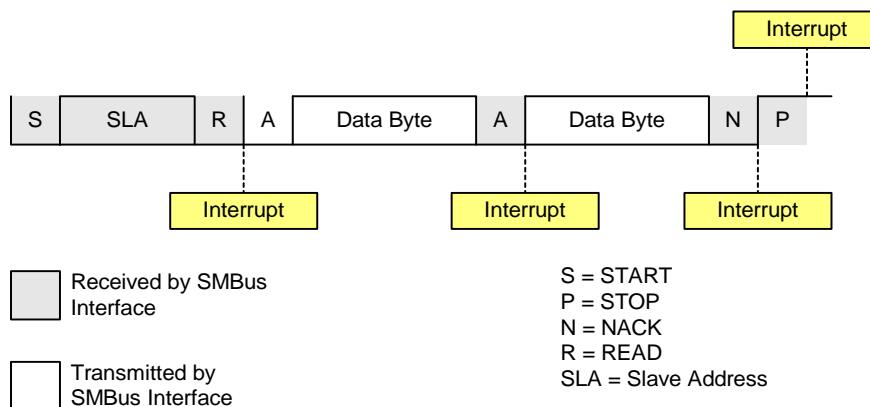

Figure 15.8. Typical Slave Transmitter Sequence

## 15.6. SMBus Status Decoding

The current SMBus status can be easily decoded using the SMB0CN register. In the table below, STATUS VECTOR refers to the four upper bits of SMB0CN: MASTER, TXMODE, STA, and STO. The shown response options are only the typical responses; application-specific procedures are allowed as long as they conform to the SMBus specification. Highlighted responses are allowed but do not conform to the SMBus specification.

### Table 15.4. SMBus Status Decoding

Mode	Values Read			Current SMBus State	Typical Response Options	Values Written			
	Status Vector	ACKRQ	ARBLOST			ACK	STA	STo	ACK
Master Transmitter	1110	0	0	X	A master START was generated.	Load slave address + R/W into SMB0DAT.	0	0	X
	1100	0	0	0	A master data or address byte was transmitted; NACK received.	Set STA to restart transfer.	1	0	X
						Abort transfer.	0	1	X
		0	0	1	A master data or address byte was transmitted; ACK received.	Load next data byte into SMB0DAT.	0	0	X
						End transfer with STOP.	0	1	X
						End transfer with STOP and start another transfer.	1	1	X
						Send repeated START.	1	0	X
				Switch to Master Receiver Mode (clear SI without writing new data to SMB0DAT).	0	0	X		
Master Receiver	1000	1	0	X	A master data byte was received; ACK requested.	Acknowledge received byte; Read SMB0DAT.	0	0	1
						Send NACK to indicate last byte, and send STOP.	0	1	0
						Send NACK to indicate last byte, and send STOP followed by START.	1	1	0
						Send ACK followed by repeated START.	1	0	1
						Send NACK to indicate last byte, and send repeated START.	1	0	0
						Send ACK and switch to Master Transmitter Mode (write to SMB0DAT before clearing SI).	0	0	1
						Send NACK and switch to Master Transmitter Mode (write to SMB0DAT before clearing SI).	0	0	0

# C8051F330/1/2/3/4/5

**Table 15.4. SMBus Status Decoding**

Mode	Values Read			Current SMBus State	Typical Response Options	Values Written			
	Status Vector	ACKRQ	ARBLOST			ACK	STA	STo	ACK
Slave Transmitter	0100	0	0	0	A slave byte was transmitted; NACK received.	No action required (expecting STOP condition).	0	0	X
		0	0	1	A slave byte was transmitted; ACK received.	Load SMB0DAT with next data byte to transmit.	0	0	X
		0	1	X	A Slave byte was transmitted; error detected.	No action required (expecting Master to end transfer).	0	0	X
	0101	0	X	X	An illegal STOP or bus error was detected while a Slave Transmission was in progress.	Clear STO.	0	0	X
Slave Receiver	0010	1	0	X	A slave address was received; ACK requested.	Acknowledge received address.	0	0	1
						Do not acknowledge received address.	0	0	0
		1	1	X	Lost arbitration as master; slave address received; ACK requested.	Acknowledge received address.	0	0	1
						Do not acknowledge received address.	0	0	0
	0010	0	1	X	Lost arbitration while attempting a repeated START.	Reschedule failed transfer; do not acknowledge received address.	1	0	0
						Abort failed transfer.	0	0	X
	0001	1	1	X	Lost arbitration while attempting a STOP.	Reschedule failed transfer.	1	0	X
						No action required (transfer complete/aborted).	0	0	0
		0	0	X	A STOP was detected while addressed as a Slave Transmitter or Slave Receiver.	Clear STO.	0	0	X
						Abort transfer.	0	0	X
		0	1	X	Lost arbitration due to a detected STOP.	Reschedule failed transfer.	1	0	X
						No action required (transfer complete/aborted).	0	0	0
	0000	1	0	X	A slave byte was received; ACK requested.	Acknowledge received byte; Read SMB0DAT.	0	0	1
						Do not acknowledge received byte.	0	0	0
1		1	X	Lost arbitration while transmitting a data byte as master.	Abort failed transfer.	0	0	0	
					Reschedule failed transfer.	1	0	0	



## 16. UART0

UART0 is an asynchronous, full duplex serial port offering modes 1 and 3 of the standard 8051 UART. Enhanced baud rate support allows a wide range of clock sources to generate standard baud rates (details in [Section “16.1. Enhanced Baud Rate Generation” on page 154](#)). Received data buffering allows UART0 to start reception of a second incoming data byte before software has finished reading the previous data byte.

UART0 has two associated SFRs: Serial Control Register 0 (SCON0) and Serial Data Buffer 0 (SBUF0). The single SBUF0 location provides access to both transmit and receive registers. **Writes to SBUF0 always access the Transmit register. Reads of SBUF0 always access the buffered Receive register; it is not possible to read data from the Transmit register.**

With UART0 interrupts enabled, an interrupt is generated each time a transmit is completed (TI0 is set in SCON0), or a data byte has been received (RI0 is set in SCON0). The UART0 interrupt flags are not cleared by hardware when the CPU vectors to the interrupt service routine. They must be cleared manually by software, allowing software to determine the cause of the UART0 interrupt (transmit complete or receive complete).

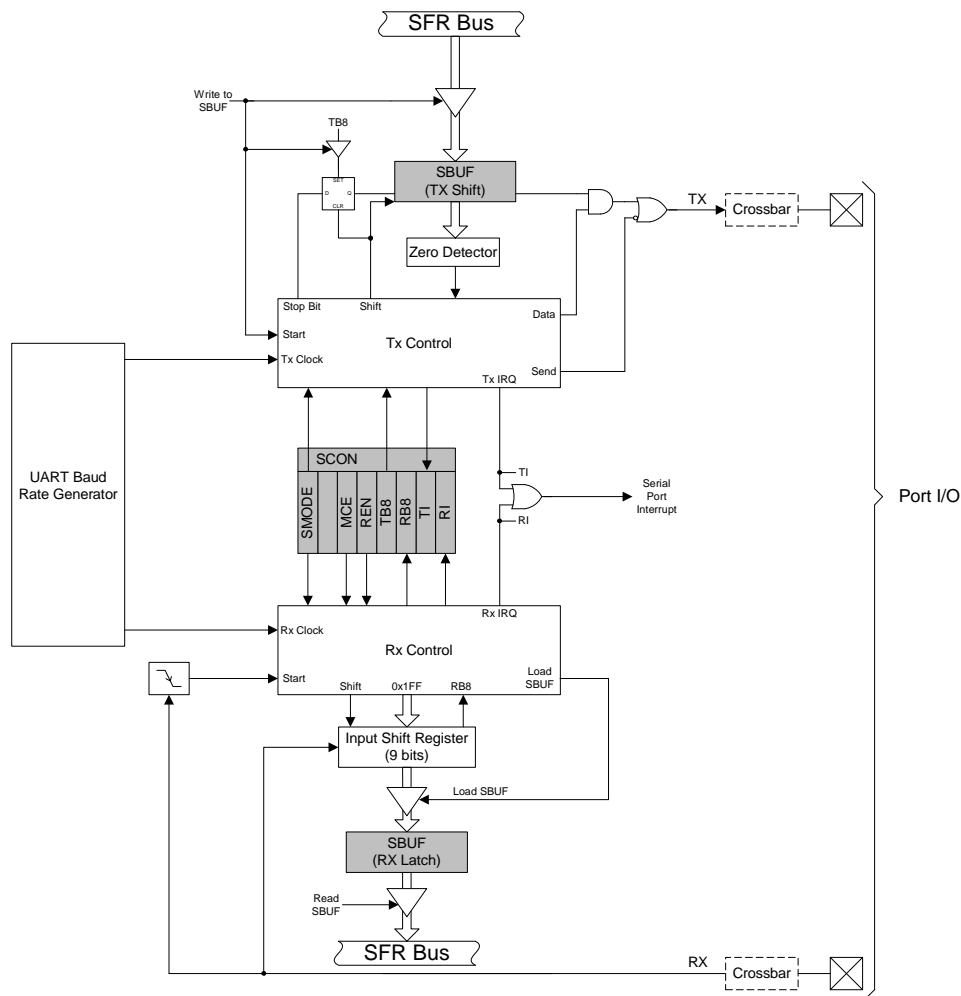
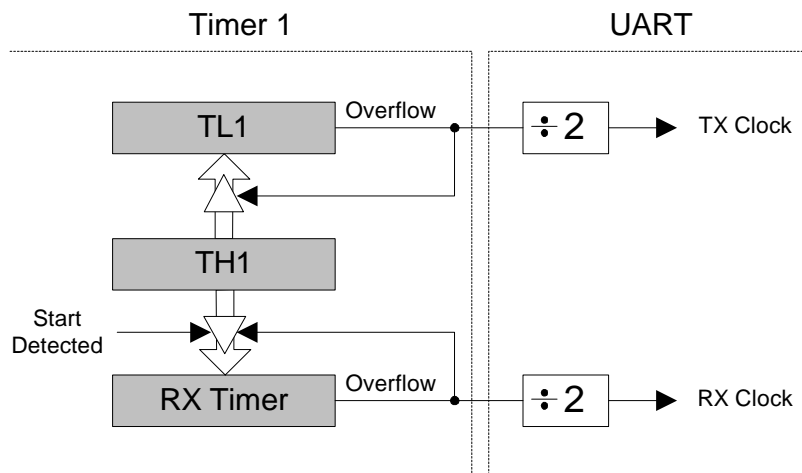

Figure 16.1. UART0 Block Diagram

## 16.1. Enhanced Baud Rate Generation

The UART0 baud rate is generated by Timer 1 in 8-bit auto-reload mode. The TX clock is generated by TL1; the RX clock is generated by a copy of TL1 (shown as RX Timer in Figure 16.2), which is not user-accessible. Both TX and RX Timer overflows are divided by two to generate the TX and RX baud rates. The RX Timer runs when Timer 1 is enabled, and uses the same reload value (TH1). However, an RX Timer reload is forced when a START condition is detected on the RX pin. This allows a receive to begin any time a START is detected, independent of the TX Timer state.



**Figure 16.2. UART0 Baud Rate Logic**

Timer 1 should be configured for Mode 2, 8-bit auto-reload (see [Section “18.1.3. Mode 2: 8-bit Counter/Timer with Auto-Reload” on page 179](#)). The Timer 1 reload value should be set so that overflows will occur at two times the desired UART baud rate frequency. Note that Timer 1 may be clocked by one of six sources: SYSCLK, SYSCLK / 4, SYSCLK / 12, SYSCLK / 48, the external oscillator clock / 8, or an external input T1. For any given Timer 1 clock source, the UART0 baud rate is determined by Equation 16.1-A and Equation 16.1-B.

$$A) \quad \text{UartBaudRate} = \frac{1}{2} \times \text{T1\_Overflow\_Rate}$$

$$B) \quad \text{T1\_Overflow\_Rate} = \frac{T1_{CLK}}{256 - TH1}$$

### Equation 16.1. UART0 Baud Rate

Where  $T1_{CLK}$  is the frequency of the clock supplied to Timer 1, and  $TH1$  is the high byte of Timer 1 (reload value). Timer 1 clock frequency is selected as described in [Section “18. Timers” on page 177](#). A quick reference for typical baud rates and system clock frequencies is given in Table 16.1 through Table 16.6. Note that the internal oscillator may still generate the system clock when the external oscillator is driving Timer 1.

## 16.2. Operational Modes

UART0 provides standard asynchronous, full duplex communication. The UART mode (8-bit or 9-bit) is selected by the S0MODE bit (SCON0.7). Typical UART connection options are shown below.

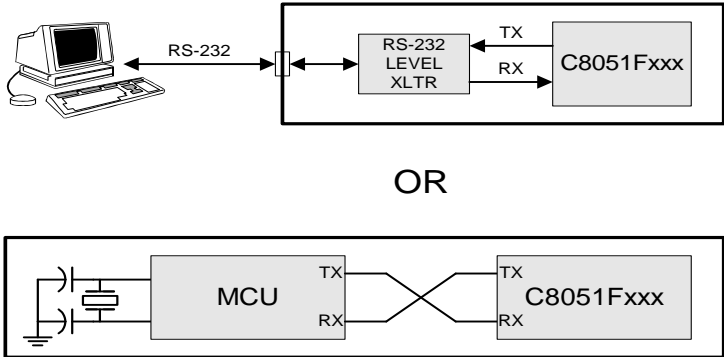

Figure 16.3. UART Interconnect Diagram

### 16.2.1. 8-Bit UART

8-Bit UART mode uses a total of 10 bits per data byte: one start bit, eight data bits (LSB first), and one stop bit. Data are transmitted LSB first from the TX0 pin and received at the RX0 pin. On receive, the eight data bits are stored in SBUF0 and the stop bit goes into RB80 (SCON0.2).

Data transmission begins when software writes a data byte to the SBUF0 register. The TIO Transmit Interrupt Flag (SCON0.1) is set at the end of the transmission (the beginning of the stop-bit time). Data reception can begin any time after the REN0 Receive Enable bit (SCON0.4) is set to logic 1. After the stop bit is received, the data byte will be loaded into the SBUF0 receive register if the following conditions are met: RI0 must be logic 0, and if MCE0 is logic 1, the stop bit must be logic 1. In the event of a receive data overrun, the first received 8 bits are latched into the SBUF0 receive register and the following overrun data bits are lost.

If these conditions are met, the eight bits of data is stored in SBUF0, the stop bit is stored in RB80 and the RI0 flag is set. If these conditions are not met, SBUF0 and RB80 will not be loaded and the RI0 flag will not be set. An interrupt will occur if enabled when either TIO or RI0 is set.

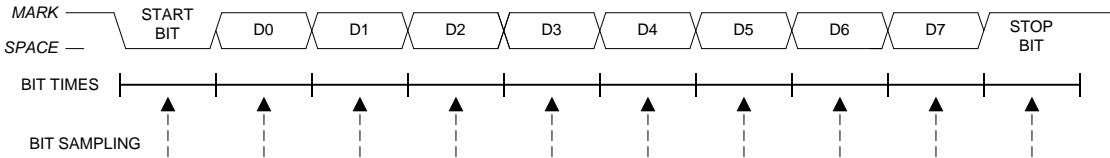

Figure 16.4. 8-Bit UART Timing Diagram

# C8051F330/1/2/3/4/5

## 16.2.2. 9-Bit UART

9-bit UART mode uses a total of eleven bits per data byte: a start bit, 8 data bits (LSB first), a programmable ninth data bit, and a stop bit. The state of the ninth transmit data bit is determined by the value in TB80 (SCON0.3), which is assigned by user software. It can be assigned the value of the parity flag (bit P in register PSW) for error detection, or used in multiprocessor communications. On receive, the ninth data bit goes into RB80 (SCON0.2) and the stop bit is ignored.

Data transmission begins when an instruction writes a data byte to the SBUF0 register. The T10 Transmit Interrupt Flag (SCON0.1) is set at the end of the transmission (the beginning of the stop-bit time). Data reception can begin any time after the REN0 Receive Enable bit (SCON0.4) is set to '1'. After the stop bit is received, the data byte will be loaded into the SBUF0 receive register if the following conditions are met: (1) R10 must be logic 0, and (2) if MCE0 is logic 1, the 9th bit must be logic 1 (when MCE0 is logic 0, the state of the ninth data bit is unimportant). If these conditions are met, the eight bits of data are stored in SBUF0, the ninth bit is stored in RB80, and the R10 flag is set to '1'. If the above conditions are not met, SBUF0 and RB80 will not be loaded and the R10 flag will not be set to '1'. A UART0 interrupt will occur if enabled when either T10 or R10 is set to '1'.

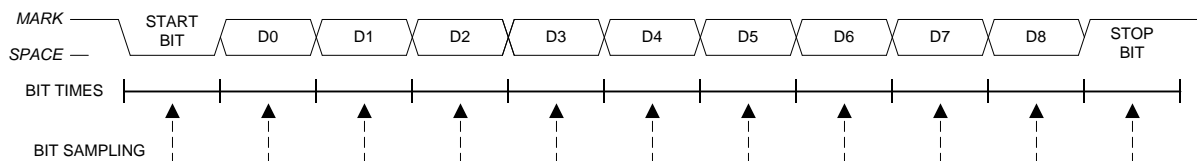

Figure 16.5. 9-Bit UART Timing Diagram

## 16.3. Multiprocessor Communications

9-Bit UART mode supports multiprocessor communication between a master processor and one or more slave processors by special use of the ninth data bit. When a master processor wants to transmit to one or more slaves, it first sends an address byte to select the target(s). An address byte differs from a data byte in that its ninth bit is logic 1; in a data byte, the ninth bit is always set to logic 0.

Setting the MCE0 bit (SCON0.5) of a slave processor configures its UART such that when a stop bit is received, the UART will generate an interrupt only if the ninth bit is logic 1 (RB80 = 1) signifying an address byte has been received. In the UART interrupt handler, software will compare the received address with the slave's own assigned 8-bit address. If the addresses match, the slave will clear its MCE0 bit to enable interrupts on the reception of the following data byte(s). Slaves that weren't addressed leave their MCE0 bits set and do not generate interrupts on the reception of the following data bytes, thereby ignoring the data. Once the entire message is received, the addressed slave resets its MCE0 bit to ignore all transmissions until it receives the next address byte.

Multiple addresses can be assigned to a single slave and/or a single address can be assigned to multiple slaves, thereby enabling "broadcast" transmissions to more than one slave simultaneously. The master processor can be configured to receive all transmissions or a protocol can be implemented such that the master/slave role is temporarily reversed to enable half-duplex transmission between the original master and slave(s).

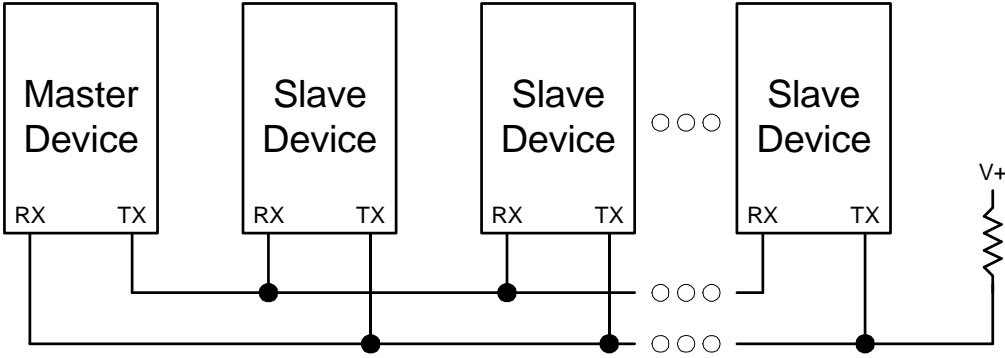

Figure 16.6. UART Multi-Processor Mode Interconnect Diagram

# C8051F330/1/2/3/4/5

## SFR Definition 16.1. SCON0: Serial Port 0 Control

R/W	R	R/W	R/W	R/W	R/W	R/W	R/W	Reset Value
S0MODE	-	MCE0	REN0	TB80	RB80	TIO	RI0	01000000
Bit7	Bit6	Bit5	Bit4	Bit3	Bit2	Bit1	Bit0	Bit Addressable
								SFR Address: 0x98
Bit7:	S0MODE: Serial Port 0 Operation Mode. This bit selects the UART0 Operation Mode. 0: 8-bit UART with Variable Baud Rate. 1: 9-bit UART with Variable Baud Rate.							
Bit6:	UNUSED. Read = 1b. Write = don't care.							
Bit5:	MCE0: Multiprocessor Communication Enable. The function of this bit is dependent on the Serial Port 0 Operation Mode. S0MODE = 0: Checks for valid stop bit. 0: Logic level of stop bit is ignored. 1: RI0 will only be activated if stop bit is logic level 1. S0MODE = 1: Multiprocessor Communications Enable. 0: Logic level of ninth bit is ignored. 1: RI0 is set and an interrupt is generated only when the ninth bit is logic 1.							
Bit4:	REN0: Receive Enable. This bit enables/disables the UART receiver. 0: UART0 reception disabled. 1: UART0 reception enabled.							
Bit3:	TB80: Ninth Transmission Bit. The logic level of this bit will be assigned to the ninth transmission bit in 9-bit UART Mode. It is not used in 8-bit UART Mode. Set or cleared by software as required.							
Bit2:	RB80: Ninth Receive Bit. RB80 is assigned the value of the STOP bit in Mode 0; it is assigned the value of the 9th data bit in Mode 1.							
Bit1:	TIO: Transmit Interrupt Flag. Set by hardware when a byte of data has been transmitted by UART0 (after the 8th bit in 8-bit UART Mode, or at the beginning of the STOP bit in 9-bit UART Mode). When the UART0 interrupt is enabled, setting this bit causes the CPU to vector to the UART0 interrupt service routine. This bit must be cleared manually by software.							
Bit0:	RI0: Receive Interrupt Flag. Set to '1' by hardware when a byte of data has been received by UART0 (set at the STOP bit sampling time). When the UART0 interrupt is enabled, setting this bit to '1' causes the CPU to vector to the UART0 interrupt service routine. This bit must be cleared manually by software.							

## SFR Definition 16.2. SBUF0: Serial (UART0) Port Data Buffer

R/W	R/W	R/W	R/W	R/W	R/W	R/W	R/W	Reset Value
								00000000
Bit7	Bit6	Bit5	Bit4	Bit3	Bit2	Bit1	Bit0	

SFR Address: 0x99

**Bits7–0: SBUF0[7:0]: Serial Data Buffer Bits 7–0 (MSB–LSB)**  
This SFR accesses two registers; a transmit shift register and a receive latch register. When data is written to SBUF0, it goes to the transmit shift register and is held for serial transmission. Writing a byte to SBUF0 initiates the transmission. A read of SBUF0 returns the contents of the receive latch.

# C8051F330/1/2/3/4/5

**Table 16.1. Timer Settings for Standard Baud Rates Using the Internal 24.5 MHz Oscillator**

Frequency: 24.5 MHz							
	Target Baud Rate (bps)	Baud Rate % Error	Oscillator Divide Factor	Timer Clock Source	SCA1–SCA0 (pre-scale select) <sup>1</sup>	T1M <sup>1</sup>	Timer 1 Reload Value (hex)
SYSCLK from Internal Osc.	230400	–0.32%	106	SYSCLK	XX <sup>2</sup>	1	0xCB
	115200	–0.32%	212	SYSCLK	XX	1	0x96
	57600	0.15%	426	SYSCLK	XX	1	0x2B
	28800	–0.32%	848	SYSCLK/4	01	0	0x96
	14400	0.15%	1704	SYSCLK/12	00	0	0xB9
	9600	–0.32%	2544	SYSCLK/12	00	0	0x96
	2400	–0.32%	10176	SYSCLK/48	10	0	0x96
	1200	0.15%	20448	SYSCLK/48	10	0	0x2B

**Notes:**

1. SCA1–SCA0 and T1M bit definitions can be found in [Section 18.1](#).
2. X = Don't care.

**Table 16.2. Timer Settings for Standard Baud Rates Using an External 25.0 MHz Oscillator**

Frequency: 25.0 MHz							
	Target Baud Rate (bps)	Baud Rate % Error	Oscillator Divide Factor	Timer Clock Source	SCA1–SCA0 (pre-scale select) <sup>1</sup>	T1M <sup>1</sup>	Timer 1 Reload Value (hex)
SYSCLK from External Osc.	230400	–0.47%	108	SYSCLK	XX <sup>2</sup>	1	0xCA
	115200	0.45%	218	SYSCLK	XX	1	0x93
	57600	–0.01%	434	SYSCLK	XX	1	0x27
	28800	0.45%	872	SYSCLK / 4	01	0	0x93
	14400	–0.01%	1736	SYSCLK / 4	01	0	0x27
	9600	0.15%	2608	EXTCLK / 8	11	0	0x5D
	2400	0.45%	10464	SYSCLK / 48	10	0	0x93
	1200	–0.01%	20832	SYSCLK / 48	10	0	0x27
SYSCLK from Internal Osc.	57600	–0.47%	432	EXTCLK / 8	11	0	0xE5
	28800	–0.47%	864	EXTCLK / 8	11	0	0xCA
	14400	0.45%	1744	EXTCLK / 8	11	0	0x93
	9600	0.15%	2608	EXTCLK / 8	11	0	0x5D

**Notes:**

1. SCA1–SCA0 and T1M bit definitions can be found in [Section 18.1](#).
2. X = Don't care.



**Table 16.3. Timer Settings for Standard Baud Rates Using an External 22.1184 MHz Oscillator**

Frequency: 22.1184 MHz							
	Target Baud Rate (bps)	Baud Rate % Error	Oscillator Divide Factor	Timer Clock Source	SCA1–SCA0 (pre-scale select) <sup>1</sup>	T1M <sup>1</sup>	Timer 1 Reload Value (hex)
SYSCLK from External Osc.	230400	0.00%	96	SYSCLK	XX <sup>2</sup>	1	0xD0
	115200	0.00%	192	SYSCLK	XX	1	0xA0
	57600	0.00%	384	SYSCLK	XX	1	0x40
	28800	0.00%	768	SYSCLK / 12	00	0	0xE0
	14400	0.00%	1536	SYSCLK / 12	00	0	0xC0
	9600	0.00%	2304	SYSCLK / 12	00	0	0xA0
	2400	0.00%	9216	SYSCLK / 48	10	0	0xA0
	1200	0.00%	18432	SYSCLK / 48	10	0	0x40
SYSCLK from Internal Osc.	230400	0.00%	96	EXTCLK / 8	11	0	0xFA
	115200	0.00%	192	EXTCLK / 8	11	0	0xF4
	57600	0.00%	384	EXTCLK / 8	11	0	0xE8
	28800	0.00%	768	EXTCLK / 8	11	0	0xD0
	14400	0.00%	1536	EXTCLK / 8	11	0	0xA0
	9600	0.00%	2304	EXTCLK / 8	11	0	0x70

**Notes:**

1. SCA1–SCA0 and T1M bit definitions can be found in [Section 18.1](#).
2. X = Don't care.

**Table 16.4. Timer Settings for Standard Baud Rates Using an External 18.432 MHz Oscillator**

Frequency: 18.432 MHz							
	Target Baud Rate (bps)	Baud Rate % Error	Oscillator Divide Factor	Timer Clock Source	SCA1–SCA0 (pre-scale select) <sup>1</sup>	T1M <sup>1</sup>	Timer 1 Reload Value (hex)
SYSCLK from External Osc.	230400	0.00%	80	SYSCLK	XX <sup>2</sup>	1	0xD8
	115200	0.00%	160	SYSCLK	XX	1	0xB0
	57600	0.00%	320	SYSCLK	XX	1	0x60
	28800	0.00%	640	SYSCLK / 4	01	0	0xB0
	14400	0.00%	1280	SYSCLK / 4	01	0	0x60
	9600	0.00%	1920	SYSCLK / 12	00	0	0xB0
	2400	0.00%	7680	SYSCLK / 48	10	0	0xB0
	1200	0.00%	15360	SYSCLK / 48	10	0	0x60
SYSCLK from Internal Osc.	230400	0.00%	80	EXTCLK / 8	11	0	0xFB
	115200	0.00%	160	EXTCLK / 8	11	0	0xF6
	57600	0.00%	320	EXTCLK / 8	11	0	0xEC
	28800	0.00%	640	EXTCLK / 8	11	0	0xD8
	14400	0.00%	1280	EXTCLK / 8	11	0	0xB0
	9600	0.00%	1920	EXTCLK / 8	11	0	0x88

**Notes:**

1. SCA1–SCA0 and T1M bit definitions can be found in [Section 18.1](#).
2. X = Don't care.

# C8051F330/1/2/3/4/5

**Table 16.5. Timer Settings for Standard Baud Rates Using an External 11.0592 MHz Oscillator**

Frequency: 11.0592 MHz							
	Target Baud Rate (bps)	Baud Rate % Error	Oscillator Divide Factor	Timer Clock Source	SCA1–SCA0 (pre-scale select) <sup>1</sup>	T1M <sup>1</sup>	Timer 1 Reload Value (hex)
SYSCLK from External Osc.	230400	0.00%	48	SYSCLK	XX <sup>2</sup>	1	0xE8
	115200	0.00%	96	SYSCLK	XX	1	0xD0
	57600	0.00%	192	SYSCLK	XX	1	0xA0
	28800	0.00%	384	SYSCLK	XX	1	0x40
	14400	0.00%	768	SYSCLK / 12	00	0	0xE0
	9600	0.00%	1152	SYSCLK / 12	00	0	0xD0
	2400	0.00%	4608	SYSCLK / 12	00	0	0x40
	1200	0.00%	9216	SYSCLK / 48	10	0	0xA0
SYSCLK from Internal Osc.	230400	0.00%	48	EXTCLK / 8	11	0	0xFD
	115200	0.00%	96	EXTCLK / 8	11	0	0xFA
	57600	0.00%	192	EXTCLK / 8	11	0	0xF4
	28800	0.00%	384	EXTCLK / 8	11	0	0xE8
	14400	0.00%	768	EXTCLK / 8	11	0	0xD0
	9600	0.00%	1152	EXTCLK / 8	11	0	0xB8

**Notes:**

1. SCA1–SCA0 and T1M bit definitions can be found in [Section 18.1](#).
2. X = Don't care.

**Table 16.6. Timer Settings for Standard Baud Rates Using an External 3.6864 MHz Oscillator**

Frequency: 3.6864 MHz							
	Target Baud Rate (bps)	Baud Rate % Error	Oscillator Divide Factor	Timer Clock Source	SCA1–SCA0 (pre-scale select) <sup>1</sup>	T1M <sup>1</sup>	Timer 1 Reload Value (hex)
SYSCLK from External Osc.	230400	0.00%	16	SYSCLK	XX <sup>2</sup>	1	0xF8
	115200	0.00%	32	SYSCLK	XX	1	0xF0
	57600	0.00%	64	SYSCLK	XX	1	0xE0
	28800	0.00%	128	SYSCLK	XX	1	0xC0
	14400	0.00%	256	SYSCLK	XX	1	0x80
	9600	0.00%	384	SYSCLK	XX	1	0x40
	2400	0.00%	1536	SYSCLK / 12	00	0	0xC0
	1200	0.00%	3072	SYSCLK / 12	00	0	0x80
SYSCLK from Internal Osc.	230400	0.00%	16	EXTCLK / 8	11	0	0xFF
	115200	0.00%	32	EXTCLK / 8	11	0	0xFE
	57600	0.00%	64	EXTCLK / 8	11	0	0xFC
	28800	0.00%	128	EXTCLK / 8	11	0	0xF8
	14400	0.00%	256	EXTCLK / 8	11	0	0xF0
	9600	0.00%	384	EXTCLK / 8	11	0	0xE8

**Notes:**

1. SCA1–SCA0 and T1M bit definitions can be found in [Section 18.1](#).
2. X = Don't care.

## 17. Enhanced Serial Peripheral Interface (SPI0)

The Enhanced Serial Peripheral Interface (SPI0) provides access to a flexible, full-duplex synchronous serial bus. SPI0 can operate as a master or slave device in both 3-wire or 4-wire modes, and supports multiple masters and slaves on a single SPI bus. The slave-select (NSS) signal can be configured as an input to select SPI0 in slave mode, or to disable Master Mode operation in a multi-master environment, avoiding contention on the SPI bus when more than one master attempts simultaneous data transfers. NSS can also be configured as a chip-select output in master mode, or disabled for 3-wire operation. Additional general purpose port I/O pins can be used to select multiple slave devices in master mode.

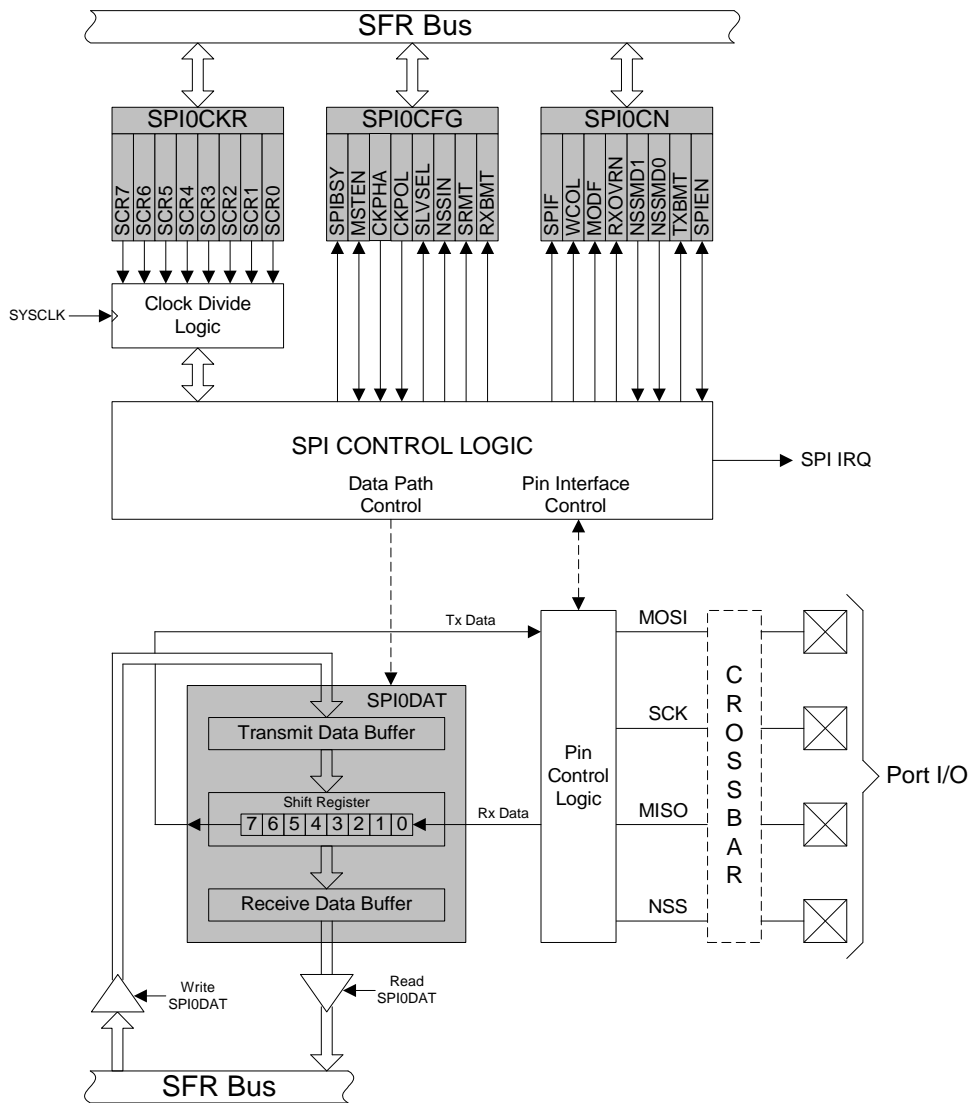

Figure 17.1. SPI Block Diagram

# C8051F330/1/2/3/4/5

---

## 17.1. Signal Descriptions

The four signals used by SPI0 (MOSI, MISO, SCK, NSS) are described below.

### 17.1.1. Master Out, Slave In (MOSI)

The master-out, slave-in (MOSI) signal is an output from a master device and an input to slave devices. It is used to serially transfer data from the master to the slave. This signal is an output when SPI0 is operating as a master and an input when SPI0 is operating as a slave. Data is transferred most-significant bit first. When configured as a master, MOSI is driven by the MSB of the shift register in both 3- and 4-wire mode.

### 17.1.2. Master In, Slave Out (MISO)

The master-in, slave-out (MISO) signal is an output from a slave device and an input to the master device. It is used to serially transfer data from the slave to the master. This signal is an input when SPI0 is operating as a master and an output when SPI0 is operating as a slave. Data is transferred most-significant bit first. The MISO pin is placed in a high-impedance state when the SPI module is disabled and when the SPI operates in 4-wire mode as a slave that is not selected. When acting as a slave in 3-wire mode, MISO is always driven by the MSB of the shift register.

### 17.1.3. Serial Clock (SCK)

The serial clock (SCK) signal is an output from the master device and an input to slave devices. It is used to synchronize the transfer of data between the master and slave on the MOSI and MISO lines. SPI0 generates this signal when operating as a master. The SCK signal is ignored by a SPI slave when the slave is not selected (NSS = 1) in 4-wire slave mode.

### 17.1.4. Slave Select (NSS)

The function of the slave-select (NSS) signal is dependent on the setting of the NSSMD1 and NSSMD0 bits in the SPI0CN register. There are three possible modes that can be selected with these bits:

1. NSSMD[1:0] = 00: 3-Wire Master or 3-Wire Slave Mode: SPI0 operates in 3-wire mode, and NSS is disabled. When operating as a slave device, SPI0 is always selected in 3-wire mode. Since no select signal is present, SPI0 must be the only slave on the bus in 3-wire mode. This is intended for point-to-point communication between a master and one slave.
2. NSSMD[1:0] = 01: 4-Wire Slave or Multi-Master Mode: SPI0 operates in 4-wire mode, and NSS is enabled as an input. When operating as a slave, NSS selects the SPI0 device. When operating as a master, a 1-to-0 transition of the NSS signal disables the master function of SPI0 so that multiple master devices can be used on the same SPI bus.
3. NSSMD[1:0] = 1x: 4-Wire Master Mode: SPI0 operates in 4-wire mode, and NSS is enabled as an output. The setting of NSSMD0 determines what logic level the NSS pin will output. This configuration should only be used when operating SPI0 as a master device.

See Figure 17.2, Figure 17.3, and Figure 17.4 for typical connection diagrams of the various operational modes. **Note that the setting of NSSMD bits affects the pinout of the device.** When in 3-wire master or 3-wire slave mode, the NSS pin will not be mapped by the crossbar. In all other modes, the NSS signal will be mapped to a pin on the device. See Section “[14. Port Input/Output](#)” on page [123](#) for general purpose port I/O and crossbar information.

## 17.2. SPI0 Master Mode Operation

A SPI master device initiates all data transfers on a SPI bus. SPI0 is placed in master mode by setting the Master Enable flag (MSTEN, SPI0CN.6). Writing a byte of data to the SPI0 data register (SPI0DAT) when in master mode writes to the transmit buffer. If the SPI shift register is empty, the byte in the transmit buffer is moved to the shift register, and a data transfer begins. The SPI0 master immediately shifts out the data serially on the MOSI line while providing the serial clock on SCK. The SPIF (SPI0CN.7) flag is set to logic 1 at the end of the transfer. If interrupts are enabled, an interrupt request is generated when the SPIF flag is set. While the SPI0 master transfers data to a slave on the MOSI line, the addressed SPI slave device simultaneously transfers the contents of its shift register to the SPI master on the MISO line in a full-duplex operation. Therefore, the SPIF flag serves as both a transmit-complete and receive-data-ready flag. The data byte received from the slave is transferred MSB-first into the master's shift register. When a byte is fully shifted into the register, it is moved to the receive buffer where it can be read by the processor by reading SPI0DAT.

When configured as a master, SPI0 can operate in one of three different modes: multi-master mode, 3-wire single-master mode, and 4-wire single-master mode. The default, multi-master mode is active when NSSMD1 (SPI0CN.3) = 0 and NSSMD0 (SPI0CN.2) = 1. In this mode, NSS is an input to the device, and is used to disable the master SPI0 when another master is accessing the bus. When NSS is pulled low in this mode, MSTEN (SPI0CN.6) and SPIEN (SPI0CN.0) are set to 0 to disable the SPI master device, and a Mode Fault is generated (MODF, SPI0CN.5 = 1). Mode Fault will generate an interrupt if enabled. SPI0 must be manually re-enabled in software under these circumstances. In multi-master systems, devices will typically default to being slave devices while they are not acting as the system master device. In multi-master mode, slave devices can be addressed individually (if needed) using general-purpose I/O pins. Figure 17.2 shows a connection diagram between two master devices in multiple-master mode.

3-wire single-master mode is active when NSSMD1 (SPI0CN.3) = 0 and NSSMD0 (SPI0CN.2) = 0. In this mode, NSS is not used, and is not mapped to an external port pin through the crossbar. Any slave devices that must be addressed in this mode should be selected using general-purpose I/O pins. Figure 17.3 shows a connection diagram between a master device in 3-wire master mode and a slave device.

4-wire single-master mode is active when NSSMD1 (SPI0CN.3) = 1. In this mode, NSS is configured as an output pin, and can be used as a slave-select signal for a single SPI device. In this mode, the output value of NSS is controlled (in software) with the bit NSSMD0 (SPI0CN.2). Additional slave devices can be addressed using general-purpose I/O pins. Figure 17.4 shows a connection diagram for a master device in 4-wire master mode and two slave devices.

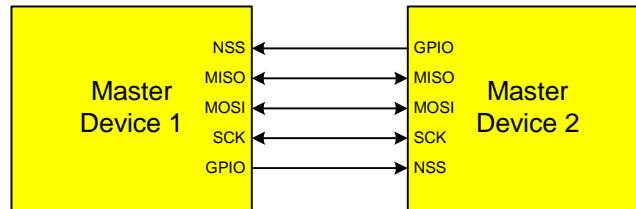

Figure 17.2. Multiple-Master Mode Connection Diagram



Figure 17.3. 3-Wire Single Master and 3-Wire Single Slave Mode Connection Diagram

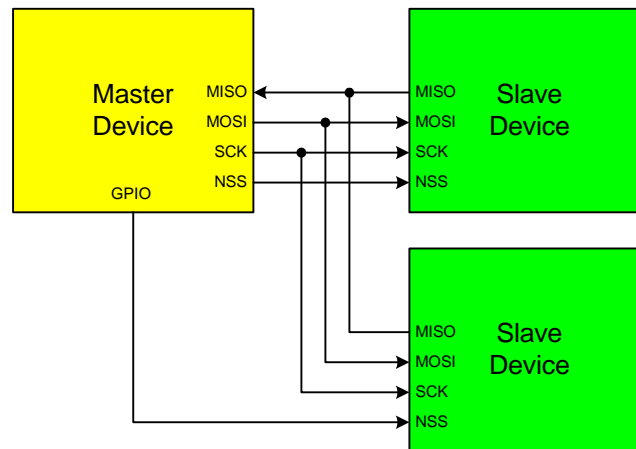

Figure 17.4. 4-Wire Single Master Mode and 4-Wire Slave Mode Connection Diagram

## 17.3. SPI0 Slave Mode Operation

When SPI0 is enabled and not configured as a master, it will operate as a SPI slave. As a slave, bytes are shifted in through the MOSI pin and out through the MISO pin by a master device controlling the SCK signal. A bit counter in the SPI0 logic counts SCK edges. When 8 bits have been shifted through the shift register, the SPIF flag is set to logic 1, and the byte is copied into the receive buffer. Data is read from the receive buffer by reading SPI0DAT. A slave device cannot initiate transfers. Data to be transferred to the master device is pre-loaded into the shift register by writing to SPI0DAT. Writes to SPI0DAT are double-buffered, and are placed in the transmit buffer first. If the shift register is empty, the contents of the transmit buffer will immediately be transferred into the shift register. When the shift register already contains data, the SPI will load the shift register with the transmit buffer's contents after the last SCK edge of the next (or current) SPI transfer.

When configured as a slave, SPI0 can be configured for 4-wire or 3-wire operation. The default, 4-wire slave mode, is active when NSSMD1 (SPI0CN.3) = 0 and NSSMD0 (SPI0CN.2) = 1. In 4-wire mode, the NSS signal is routed to a port pin and configured as a digital input. SPI0 is enabled when NSS is logic 0, and disabled when NSS is logic 1. The bit counter is reset on a falling edge of NSS. Note that the NSS signal must be driven low at least 2 system clocks before the first active edge of SCK for each byte transfer. Figure 17.4 shows a connection diagram between two slave devices in 4-wire slave mode and a master device.

3-wire slave mode is active when NSSMD1 (SPI0CN.3) = 0 and NSSMD0 (SPI0CN.2) = 0. NSS is not used in this mode, and is not mapped to an external port pin through the crossbar. Since there is no way of uniquely addressing the device in 3-wire slave mode, SPI0 must be the only slave device present on the bus. It is important to note that in 3-wire slave mode there is no external means of resetting the bit counter that determines when a full byte has been received. The bit counter can only be reset by disabling and re-enabling SPI0 with the SPIEN bit. Figure 17.3 shows a connection diagram between a slave device in 3-wire slave mode and a master device.

## 17.4. SPI0 Interrupt Sources

When SPI0 interrupts are enabled, the following four flags will generate an interrupt when they are set to logic 1:

*All of the following bits must be cleared by software.*

1. The SPI Interrupt Flag, SPIF (SPI0CN.7) is set to logic 1 at the end of each byte transfer. This flag can occur in all SPI0 modes.
2. The Write Collision Flag, WCOL (SPI0CN.6) is set to logic 1 if a write to SPI0DAT is attempted when the transmit buffer has not been emptied to the SPI shift register. When this occurs, the write to SPI0DAT will be ignored, and the transmit buffer will not be written. This flag can occur in all SPI0 modes.
3. The Mode Fault Flag MODF (SPI0CN.5) is set to logic 1 when SPI0 is configured as a master, and for multi-master mode and the NSS pin is pulled low. When a Mode Fault occurs, the MSTEN and SPIEN bits in SPI0CN are set to logic 0 to disable SPI0 and allow another master device to access the bus.
4. The Receive Overrun Flag RXOVRN (SPI0CN.4) is set to logic 1 when configured as a slave, and a transfer is completed and the receive buffer still holds an unread byte from a previous transfer. The new byte is not transferred to the receive buffer, allowing the previously received data byte to be read. The data byte which caused the overrun is lost.

# C8051F330/1/2/3/4/5

## 17.5. Serial Clock Timing

Four combinations of serial clock phase and polarity can be selected using the clock control bits in the SPI0 Configuration Register (SPI0CFG). The CKPHA bit (SPI0CFG.5) selects one of two clock phases (edge used to latch the data). The CKPOL bit (SPI0CFG.4) selects between an active-high or active-low clock. Both master and slave devices must be configured to use the same clock phase and polarity. SPI0 should be disabled (by clearing the SPIEN bit, SPI0CN.0) when changing the clock phase or polarity. The clock and data line relationships for master mode are shown in Figure 17.5. For slave mode, the clock and data relationships are shown in Figure 17.6 and Figure 17.7. Note that CKPHA must be set to '0' on both the master and slave SPI when communicating between two of the following devices: C8051F04x, C8051F06x, C8051F12x, C8051F31x, C8051F32x, and C8051F33x

The SPI0 Clock Rate Register (SPI0CKR) as shown in SFR Definition 17.3 controls the master mode serial clock frequency. This register is ignored when operating in slave mode. When the SPI is configured as a master, the maximum data transfer rate (bits/sec) is one-half the system clock frequency or 12.5 MHz, whichever is slower. When the SPI is configured as a slave, the maximum data transfer rate (bits/sec) for full-duplex operation is 1/10 the system clock frequency, provided that the master issues SCK, NSS (in 4-wire slave mode), and the serial input data synchronously with the slave's system clock. If the master issues SCK, NSS, and the serial input data asynchronously, the maximum data transfer rate (bits/sec) must be less than 1/10 the system clock frequency. In the special case where the master only wants to transmit data to the slave and does not need to receive data from the slave (i.e. half-duplex operation), the SPI slave can receive data at a maximum data transfer rate (bits/sec) of 1/4 the system clock frequency. This is provided that the master issues SCK, NSS, and the serial input data synchronously with the slave's system clock.

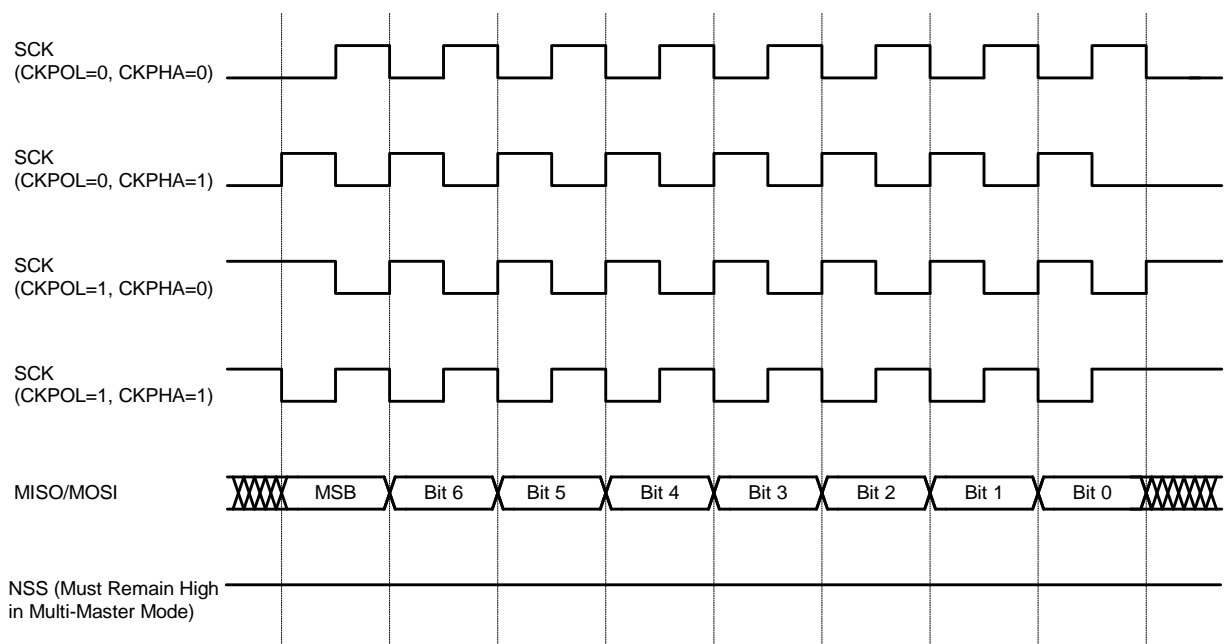
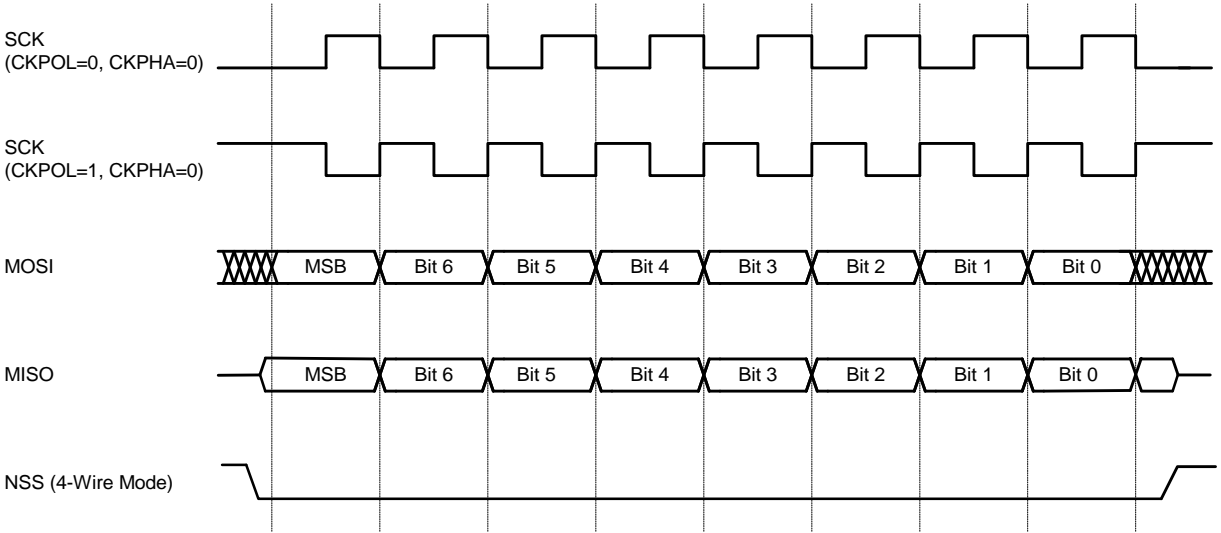
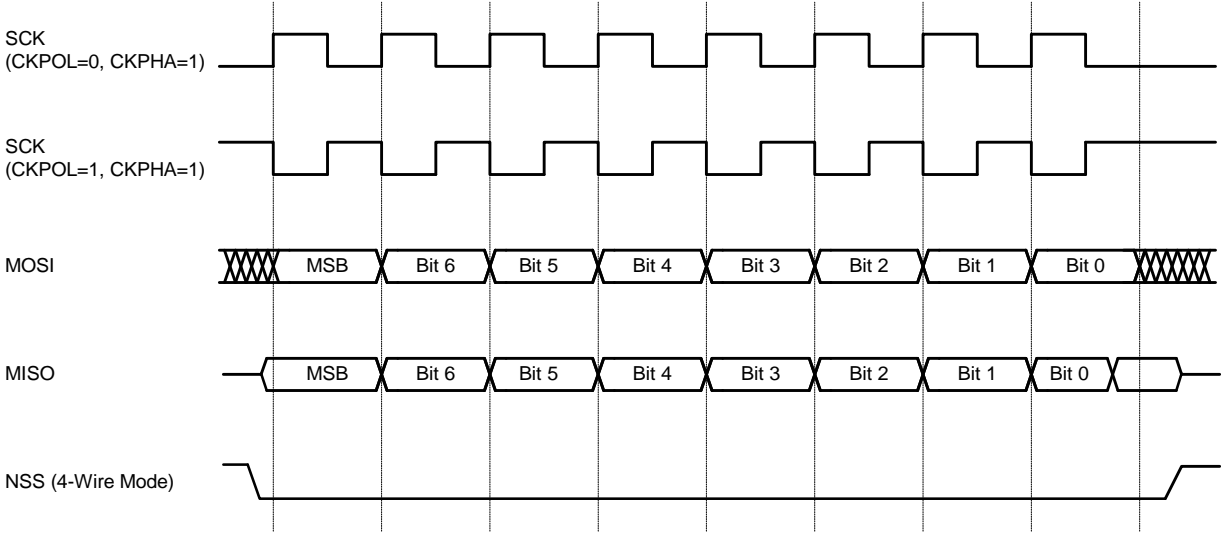

Figure 17.5. Master Mode Data/Clock Timing





**Figure 17.6. Slave Mode Data/Clock Timing (CKPHA = 0)**



**Figure 17.7. Slave Mode Data/Clock Timing (CKPHA = 1)**

### 17.6. SPI Special Function Registers

SPI0 is accessed and controlled through four special function registers in the system controller: SPI0CN Control Register, SPI0DAT Data Register, SPI0CFG Configuration Register, and SPI0CKR Clock Rate Register. The four special function registers related to the operation of the SPI0 Bus are described in the following figures.

# C8051F330/1/2/3/4/5

## SFR Definition 17.1. SPI0CFG: SPI0 Configuration

R	R/W	R/W	R/W	R	R	R	R	Reset Value
SPIBSY	MSTEN	CKPHA	CKPOL	SLVSEL	NSSIN	SRMT	RXBMT	00000111
Bit7	Bit6	Bit5	Bit4	Bit3	Bit2	Bit1	Bit0	

SFR Address: 0xA1

Bit 7: SPIBSY: SPI Busy (read only).  
This bit is set to logic 1 when a SPI transfer is in progress (Master or slave Mode).

Bit 6: MSTEN: Master Mode Enable.  
0: Disable master mode. Operate in slave mode.  
1: Enable master mode. Operate as a master.

Bit 5: CKPHA: SPI0 Clock Phase.  
This bit controls the SPI0 clock phase.  
0: Data centered on first edge of SCK period.\*  
1: Data centered on second edge of SCK period.\*

Bit 4: CKPOL: SPI0 Clock Polarity.  
This bit controls the SPI0 clock polarity.  
0: SCK line low in idle state.  
1: SCK line high in idle state.

Bit 3: SLVSEL: Slave Selected Flag (read only).  
This bit is set to logic 1 whenever the NSS pin is low indicating SPI0 is the selected slave. It is cleared to logic 0 when NSS is high (slave not selected). This bit does not indicate the instantaneous value at the NSS pin, but rather a de-glitched version of the pin input.

Bit 2: NSSIN: NSS Instantaneous Pin Input (read only).  
This bit mimics the instantaneous value that is present on the NSS port pin at the time that the register is read. This input is not de-glitched.

Bit 1: SRMT: Shift Register Empty (Valid in Slave Mode, read only).  
This bit will be set to logic 1 when all data has been transferred in/out of the shift register, and there is no new information available to read from the transmit buffer or write to the receive buffer. It returns to logic 0 when a data byte is transferred to the shift register from the transmit buffer or by a transition on SCK.  
NOTE: SRMT = 1 when in Master Mode.

Bit 0: RXBMT: Receive Buffer Empty (Valid in Slave Mode, read only).  
This bit will be set to logic 1 when the receive buffer has been read and contains no new information. If there is new information available in the receive buffer that has not been read, this bit will return to logic 0.  
NOTE: RXBMT = 1 when in Master Mode.

**\*Note:** In slave mode, data on MOSI is sampled in the center of each data bit. In master mode, data on MISO is sampled one SYSCLK before the end of each data bit, to provide maximum settling time for the slave device. See Table 17.1 for timing parameters.

## SFR Definition 17.2. SPI0CN: SPI0 Control

R/W	R/W	R/W	R/W	R/W	R/W	R	R/W	Reset Value
SPIF	WCOL	MODF	RXOVRN	NSSMD1	NSSMD0	TXBMT	SPIEN	00000110
Bit7	Bit6	Bit5	Bit4	Bit3	Bit2	Bit1	Bit0	Bit Addressable
SFR Address: 0xF8								
Bit 7:	<p><b>SPIF: SPI0 Interrupt Flag.</b> This bit is set to logic 1 by hardware at the end of a data transfer. If interrupts are enabled, setting this bit causes the CPU to vector to the SPI0 interrupt service routine. This bit is not automatically cleared by hardware. It must be cleared by software.</p>							
Bit 6:	<p><b>WCOL: Write Collision Flag.</b> This bit is set to logic 1 by hardware if a write to SPI0DAT is attempted when the transmit buffer has not been emptied to the SPI shift register. It must be cleared by software.</p>							
Bit 5:	<p><b>MODF: Mode Fault Flag.</b> This bit is set to logic 1 by hardware (and generates a SPI0 interrupt) when a master mode collision is detected (NSS is low, MSTEN = 1, and NSSMD[1:0] = 01). This bit is not automatically cleared by hardware. It must be cleared by software.</p>							
Bit 4:	<p><b>RXOVRN: Receive Overrun Flag (Slave Mode only).</b> This bit is set to logic 1 by hardware (and generates a SPI0 interrupt) when the receive buffer still holds unread data from a previous transfer and the last bit of the current transfer is shifted into the SPI0 shift register. This bit is not automatically cleared by hardware. It must be cleared by software.</p>							
Bits 3–2:	<p><b>NSSMD1–NSSMD0: Slave Select Mode.</b> Selects between the following NSS operation modes: (See <a href="#">Section “17.2. SPI0 Master Mode Operation” on page 165</a> and <a href="#">Section “17.3. SPI0 Slave Mode Operation” on page 167</a>).</p> <p>00: 3-Wire Slave or 3-wire Master Mode. NSS signal is not routed to a port pin. 01: 4-Wire Slave or Multi-Master Mode (Default). NSS is always an input to the device. 1x: 4-Wire Single-Master Mode. NSS signal is mapped as an output from the device and will assume the value of NSSMD0.</p>							
Bit 1:	<p><b>TXBMT: Transmit Buffer Empty.</b> This bit will be set to logic 0 when new data has been written to the transmit buffer. When data in the transmit buffer is transferred to the SPI shift register, this bit will be set to logic 1, indicating that it is safe to write a new byte to the transmit buffer.</p>							
Bit 0:	<p><b>SPIEN: SPI0 Enable.</b> This bit enables/disables the SPI. 0: SPI disabled. 1: SPI enabled.</p>							

# C8051F330/1/2/3/4/5

## SFR Definition 17.3. SPI0CKR: SPI0 Clock Rate

R/W	R/W	R/W	R/W	R/W	R/W	R/W	R/W	Reset Value
SCR7	SCR6	SCR5	SCR4	SCR3	SCR2	SCR1	SCR0	00000000
Bit7	Bit6	Bit5	Bit4	Bit3	Bit2	Bit1	Bit0	

SFR Address: 0xA2

Bits 7–0: SCR7–SCR0: SPI0 Clock Rate.

These bits determine the frequency of the SCK output when the SPI0 module is configured for master mode operation. The SCK clock frequency is a divided version of the system clock, and is given in the following equation, where *SYSCLK* is the system clock frequency and *SPI0CKR* is the 8-bit value held in the SPI0CKR register.

$$f_{SCK} = \frac{SYSCLK}{2 \times (SPI0CKR + 1)}$$

for  $0 \leq SPI0CKR \leq 255$

Example: If *SYSCLK* = 2 MHz and *SPI0CKR* = 0x04,

$$f_{SCK} = \frac{2000000}{2 \times (4 + 1)}$$

$$f_{SCK} = 200kHz$$

## SFR Definition 17.4. SPI0DAT: SPI0 Data

R/W	R/W	R/W	R/W	R/W	R/W	R/W	R/W	Reset Value
								00000000
Bit7	Bit6	Bit5	Bit4	Bit3	Bit2	Bit1	Bit0	

SFR Address: 0xA3

Bits 7–0: SPI0DAT: SPI0 Transmit and Receive Data.

The SPI0DAT register is used to transmit and receive SPI0 data. Writing data to SPI0DAT places the data into the transmit buffer and initiates a transfer when in Master Mode. A read of SPI0DAT returns the contents of the receive buffer.

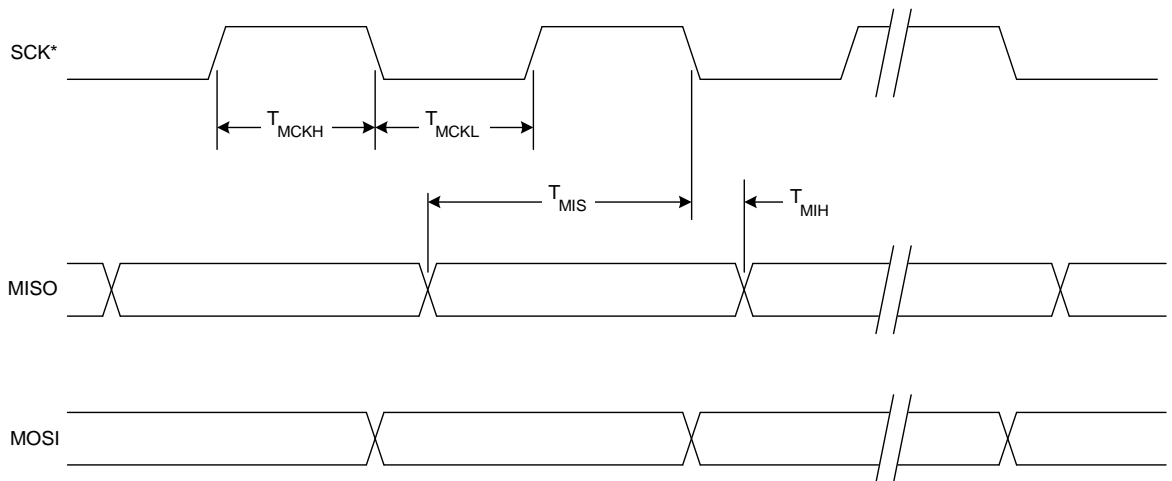

\* SCK is shown for CKPOL = 0. SCK is the opposite polarity for CKPOL = 1.

Figure 17.8. SPI Master Timing (CKPHA = 0)

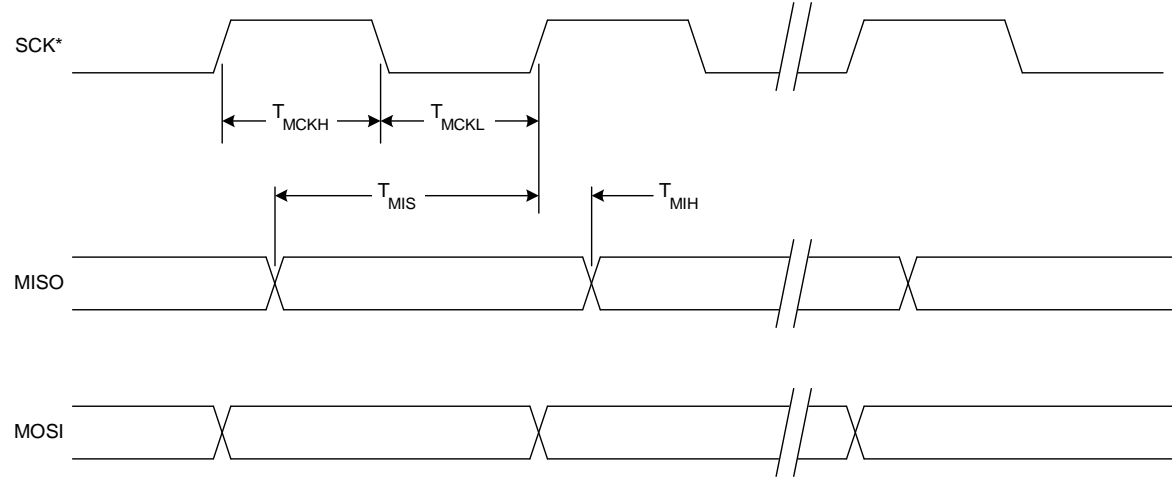

\* SCK is shown for CKPOL = 0. SCK is the opposite polarity for CKPOL = 1.

Figure 17.9. SPI Master Timing (CKPHA = 1)

# C8051F330/1/2/3/4/5

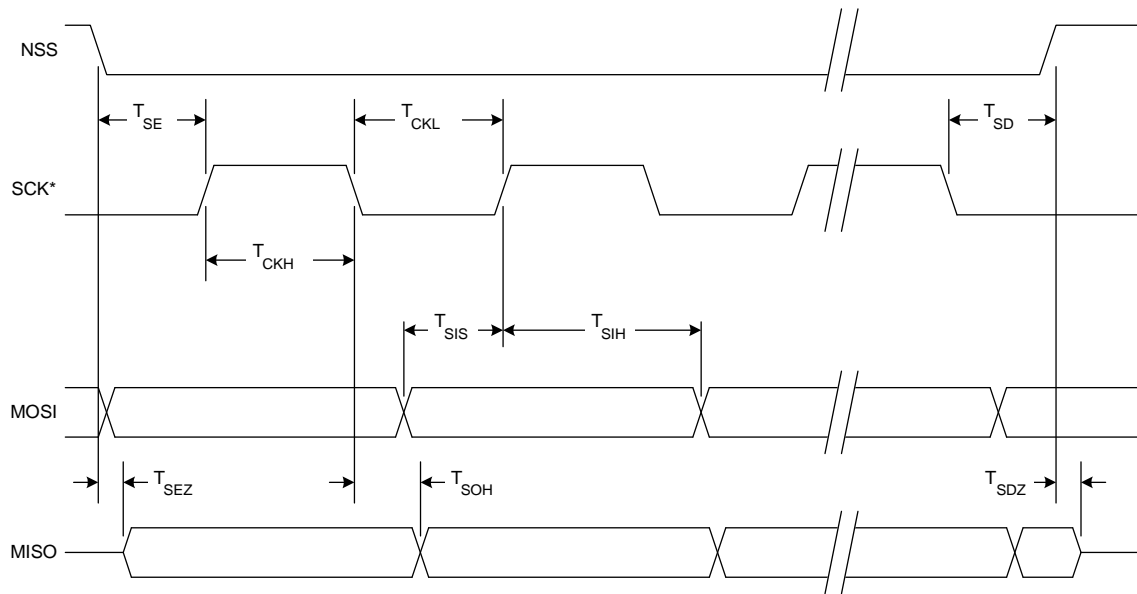

\* SCK is shown for CKPOL = 0. SCK is the opposite polarity for CKPOL = 1.

**Figure 17.10. SPI Slave Timing (CKPHA = 0)**

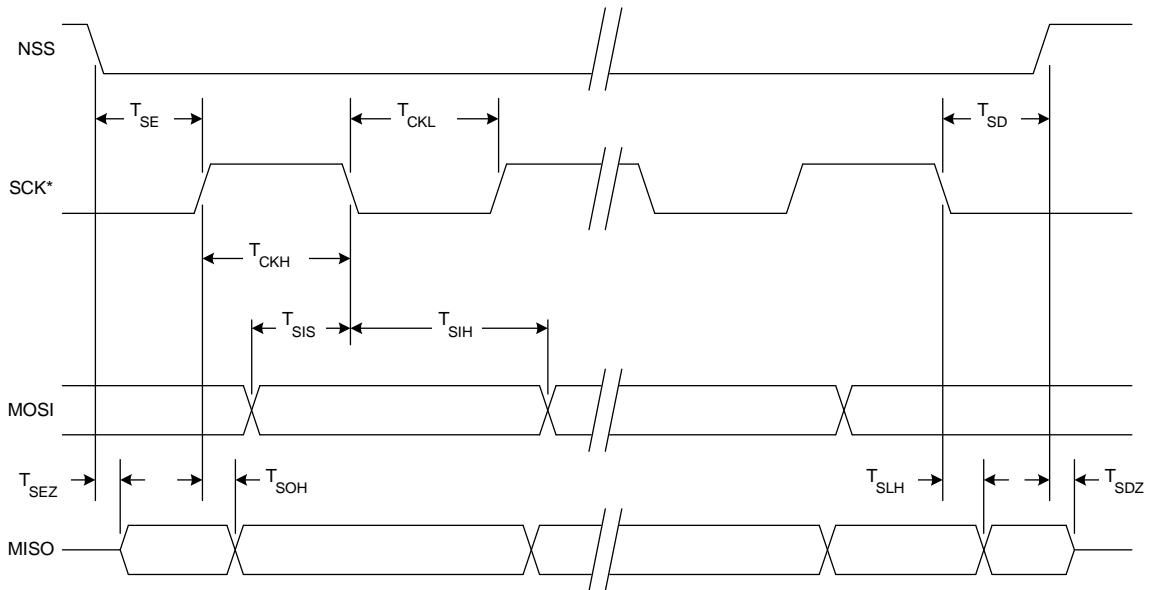

\* SCK is shown for CKPOL = 0. SCK is the opposite polarity for CKPOL = 1.

**Figure 17.11. SPI Slave Timing (CKPHA = 1)**

**Table 17.1. SPI Slave Timing Parameters**

Parameter	Description	Min	Max	Units
<b>Master Mode Timing*</b> (See Figure 17.8 and Figure 17.9)				
$T_{MCKH}$	SCK High Time	$1 \times T_{SYSCLK}$	—	ns
$T_{MCKL}$	SCK Low Time	$1 \times T_{SYSCLK}$	—	ns
$T_{MIS}$	MISO Valid to SCK Shift Edge	$1 \times T_{SYSCLK} + 20$	—	ns
$T_{MIH}$	SCK Shift Edge to MISO Change	0	—	ns
<b>Slave Mode Timing*</b> (See Figure 17.10 and Figure 17.11)				
$T_{SE}$	NSS Falling to First SCK Edge	$2 \times T_{SYSCLK}$	—	ns
$T_{SD}$	Last SCK Edge to NSS Rising	$2 \times T_{SYSCLK}$	—	ns
$T_{SEZ}$	NSS Falling to MISO Valid	—	$4 \times T_{SYSCLK}$	ns
$T_{SDZ}$	NSS Rising to MISO High-Z	—	$4 \times T_{SYSCLK}$	ns
$T_{CKH}$	SCK High Time	$5 \times T_{SYSCLK}$	—	ns
$T_{CKL}$	SCK Low Time	$5 \times T_{SYSCLK}$	—	ns
$T_{SIS}$	MOSI Valid to SCK Sample Edge	$2 \times T_{SYSCLK}$	—	ns
$T_{SIH}$	SCK Sample Edge to MOSI Change	$2 \times T_{SYSCLK}$	—	ns
$T_{SOH}$	SCK Shift Edge to MISO Change	—	$4 \times T_{SYSCLK}$	ns
$T_{SLH}$	Last SCK Edge to MISO Change (CKPHA = 1 ONLY)	$6 \times T_{SYSCLK}$	$8 \times T_{SYSCLK}$	ns
<b>*Note:</b> $T_{SYSCLK}$ is equal to one period of the device system clock (SYSCLK).				

# C8051F330/1/2/3/4/5

---



## 18. Timers

Each MCU includes four counter/timers: two are 16-bit counter/timers compatible with those found in the standard 8051, and two are 16-bit auto-reload timer for use with the ADC, SMBus, or for general purpose use. These timers can be used to measure time intervals, count external events and generate periodic interrupt requests. Timer 0 and Timer 1 are nearly identical and have four primary modes of operation. Timer 2 and Timer 3 offer 16-bit and split 8-bit timer functionality with auto-reload

Timer 0 and Timer 1 Modes:	Timer 2 Modes:	Timer 3 Modes:
13-bit counter/timer	16-bit timer with auto-reload	16-bit timer with auto-reload
16-bit counter/timer		
8-bit counter/timer with auto-reload	Two 8-bit timers with auto-reload	Two 8-bit timers with auto-reload
Two 8-bit counter/timers (Timer 0 only)		

Timers 0 and 1 may be clocked by one of five sources, determined by the Timer Mode Select bits (T1M–T0M) and the Clock Scale bits (SCA1–SCA0). The Clock Scale bits define a pre-scaled clock from which Timer 0 and/or Timer 1 may be clocked (See SFR Definition 18.3 for pre-scaled clock selection).

Timer 0/1 may then be configured to use this pre-scaled clock signal or the system clock. Timer 2 and Timer 3 may be clocked by the system clock, the system clock divided by 12, or the external oscillator clock source divided by 8.

Timer 0 and Timer 1 may also be operated as counters. When functioning as a counter, a counter/timer register is incremented on each high-to-low transition at the selected input pin (T0 or T1). Events with a frequency of up to one-fourth the system clock frequency can be counted. The input signal need not be periodic, but it should be held at a given level for at least two full system clock cycles to ensure the level is properly sampled.

### 18.1. Timer 0 and Timer 1

Each timer is implemented as a 16-bit register accessed as two separate bytes: a low byte (TL0 or TL1) and a high byte (TH0 or TH1). The Counter/Timer Control register (TCON) is used to enable Timer 0 and Timer 1 as well as indicate status. Timer 0 interrupts can be enabled by setting the ET0 bit in the IE register (Section “9.3.5. Interrupt Register Descriptions” on page 89); Timer 1 interrupts can be enabled by setting the ET1 bit in the IE register (Section 9.3.5). Both counter/timers operate in one of four primary modes selected by setting the Mode Select bits T1M1–T0M0 in the Counter/Timer Mode register (TMOD). Each timer can be configured independently. Each operating mode is described below.

#### 18.1.1. Mode 0: 13-bit Counter/Timer

Timer 0 and Timer 1 operate as 13-bit counter/timers in Mode 0. The following describes the configuration and operation of Timer 0. However, both timers operate identically, and Timer 1 is configured in the same manner as described for Timer 0.

The TH0 register holds the eight MSBs of the 13-bit counter/timer. TL0 holds the five LSBs in bit positions TL0.4–TL0.0. The three upper bits of TL0 (TL0.7–TL0.5) are indeterminate and should be masked out or ignored when reading. As the 13-bit timer register increments and overflows from 0x1FFF (all ones) to 0x0000, the timer overflow flag TF0 (TCON.5) is set and an interrupt will occur if Timer 0 interrupts are enabled.

# C8051F330/1/2/3/4/5

The C/T0 bit (TMOD.2) selects the counter/timer's clock source. When C/T0 is set to logic 1, high-to-low transitions at the selected Timer 0 input pin (T0) increment the timer register (Refer to [Section "14.1. Priority Crossbar Decoder" on page 125](#) for information on selecting and configuring external I/O pins). Clearing C/T selects the clock defined by the T0M bit (CKCON.3). When T0M is set, Timer 0 is clocked by the system clock. When T0M is cleared, Timer 0 is clocked by the source selected by the Clock Scale bits in CKCON (see SFR Definition 18.3).

Setting the TR0 bit (TCON.4) enables the timer when either GATE0 (TMOD.3) is logic 0 or the input signal /INT0 is active as defined by bit IN0PL in register IT01CF (see SFR Definition 9.11). Setting GATE0 to '1' allows the timer to be controlled by the external input signal /INT0 (see [Section "9.3.5. Interrupt Register Descriptions" on page 89](#)), facilitating pulse width measurements

TR0	GATE0	/INT0	Counter/Timer
0	X	X	Disabled
1	0	X	Enabled
1	1	0	Disabled
1	1	1	Enabled

**Note:** X = Don't Care

Setting TR0 does not force the timer to reset. The timer registers should be loaded with the desired initial value before the timer is enabled.

TL1 and TH1 form the 13-bit register for Timer 1 in the same manner as described above for TL0 and TH0. Timer 1 is configured and controlled using the relevant TCON and TMOD bits just as with Timer 0. The input signal /INT1 is used with Timer 1; the /INT1 polarity is defined by bit IN1PL in register IT01CF (see SFR Definition 9.11).

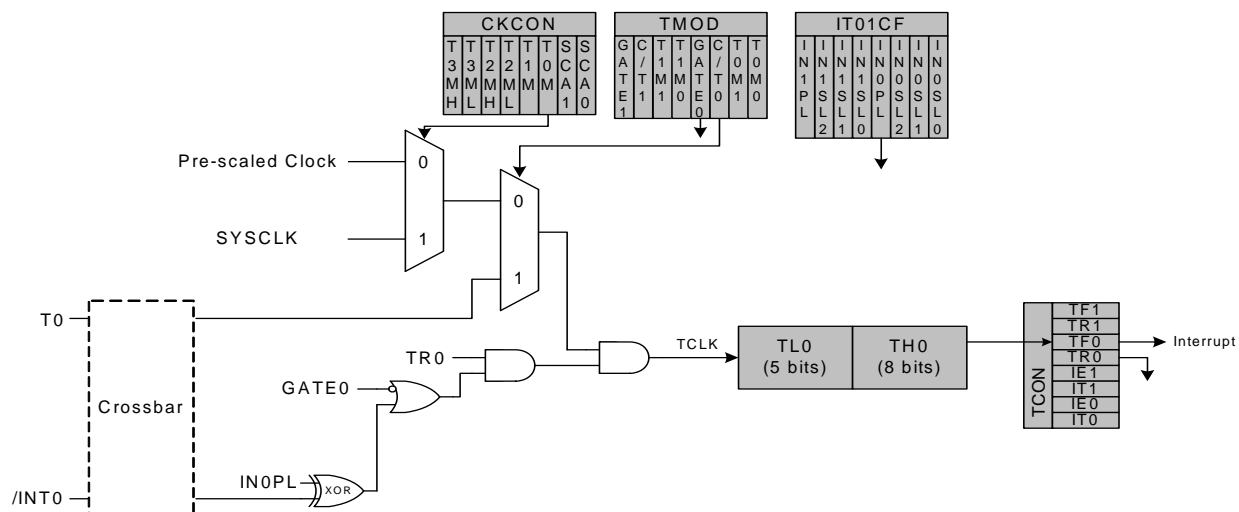

**Figure 18.1. T0 Mode 0 Block Diagram**

## 18.1.2. Mode 1: 16-bit Counter/Timer

Mode 1 operation is the same as Mode 0, except that the counter/timer registers use all 16 bits. The counter/timers are enabled and configured in Mode 1 in the same manner as for Mode 0.

## 18.1.3. Mode 2: 8-bit Counter/Timer with Auto-Reload

Mode 2 configures Timer 0 and Timer 1 to operate as 8-bit counter/timers with automatic reload of the start value. TL0 holds the count and TH0 holds the reload value. When the counter in TL0 overflows from all ones to 0x00, the timer overflow flag TF0 (TCON.5) is set and the counter in TL0 is reloaded from TH0. If Timer 0 interrupts are enabled, an interrupt will occur when the TF0 flag is set. The reload value in TH0 is not changed. TL0 must be initialized to the desired value before enabling the timer for the first count to be correct. When in Mode 2, Timer 1 operates identically to Timer 0.

Both counter/timers are enabled and configured in Mode 2 in the same manner as Mode 0. Setting the TR0 bit (TCON.4) enables the timer when either GATE0 (TMOD.3) is logic 0 or when the input signal /INT0 is active as defined by bit IN0PL in register IT01CF (see Section “9.3.2. External Interrupts” on page 87 for details on the external input signals /INT0 and /INT1).

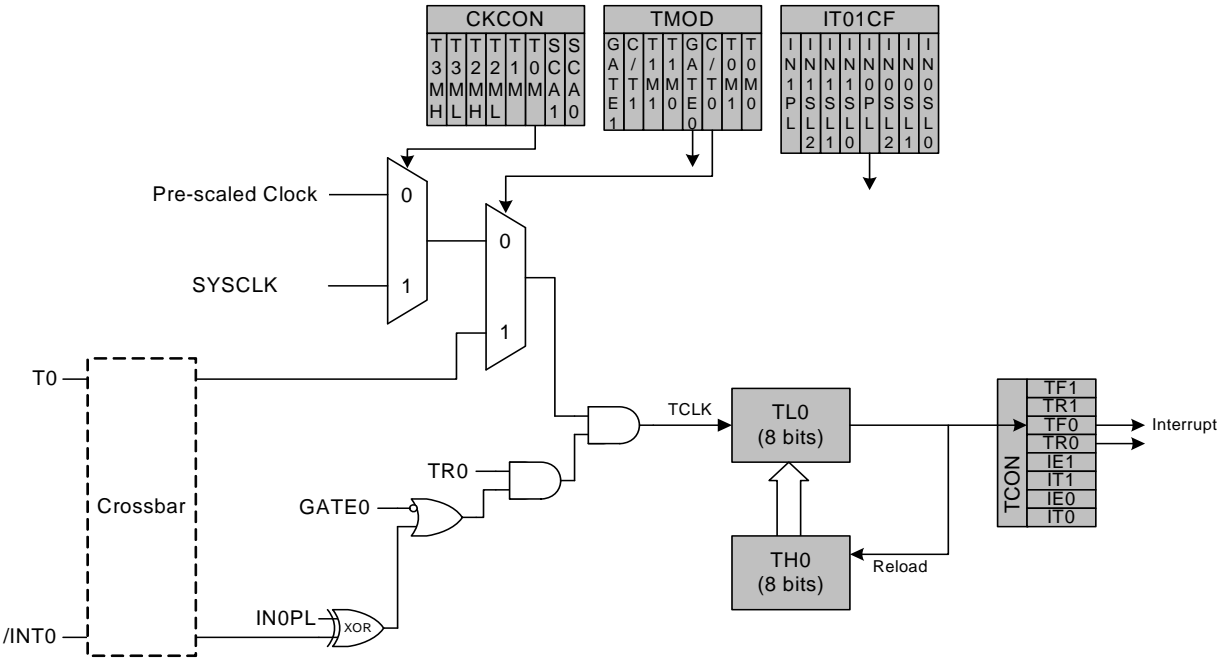

Figure 18.2. T0 Mode 2 Block Diagram

# C8051F330/1/2/3/4/5

## 18.1.4. Mode 3: Two 8-bit Counter/Timers (Timer 0 Only)

In Mode 3, Timer 0 is configured as two separate 8-bit counter/timers held in TL0 and TH0. The counter/timer in TL0 is controlled using the Timer 0 control/status bits in TCON and TMOD: TR0, C/T0, GATE0 and TF0. TL0 can use either the system clock or an external input signal as its timebase. The TH0 register is restricted to a timer function sourced by the system clock or prescaled clock. TH0 is enabled using the Timer 1 run control bit TR1. TH0 sets the Timer 1 overflow flag TF1 on overflow and thus controls the Timer 1 interrupt.

Timer 1 is inactive in Mode 3. When Timer 0 is operating in Mode 3, Timer 1 can be operated in Modes 0, 1 or 2, but cannot be clocked by external signals nor set the TF1 flag and generate an interrupt. However, the Timer 1 overflow can be used to generate baud rates for the SMBus and/or UART, and/or initiate ADC conversions. While Timer 0 is operating in Mode 3, Timer 1 run control is handled through its mode settings. To run Timer 1 while Timer 0 is in Mode 3, set the Timer 1 Mode as 0, 1, or 2. To disable Timer 1, configure it for Mode 3.

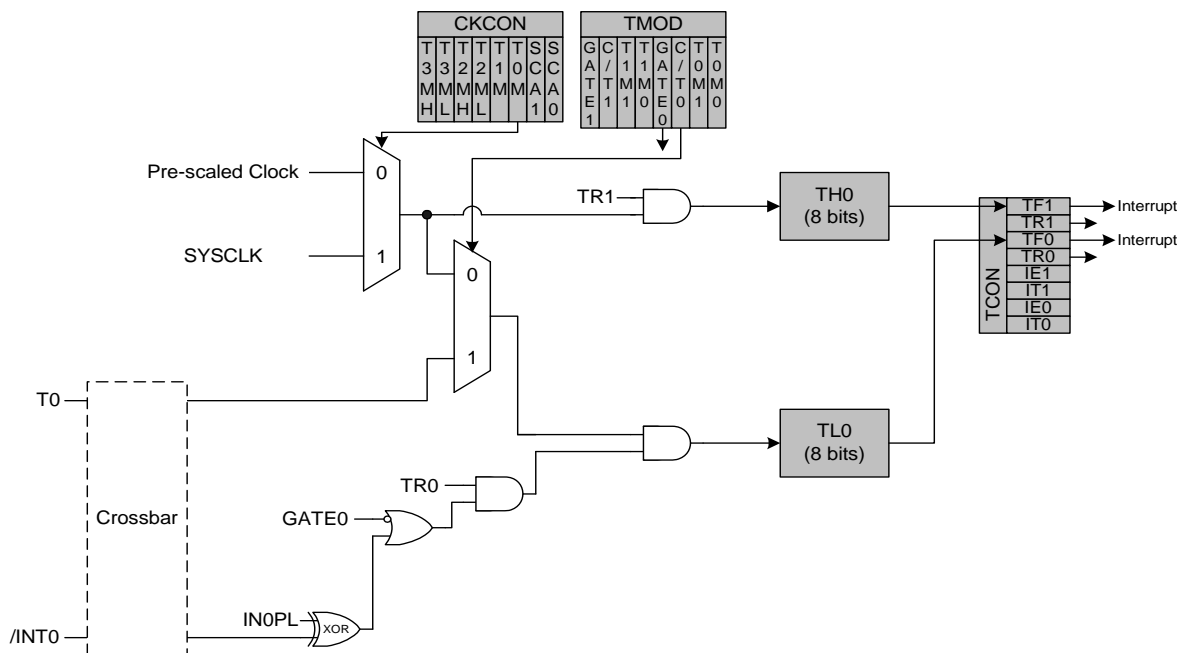

Figure 18.3. T0 Mode 3 Block Diagram

## SFR Definition 18.1. TCON: Timer Control

R/W	R/W	R/W	R/W	R/W	R/W	R/W	R/W	Reset Value
TF1	TR1	TF0	TR0	IE1	IT1	IE0	IT0	00000000
Bit7	Bit6	Bit5	Bit4	Bit3	Bit2	Bit1	Bit0	SFR Address: 0x88
							(bit addressable)	
Bit7:	<p>TF1: Timer 1 Overflow Flag. Set by hardware when Timer 1 overflows. This flag can be cleared by software but is automatically cleared when the CPU vectors to the Timer 1 interrupt service routine. 0: No Timer 1 overflow detected. 1: Timer 1 has overflowed.</p>							
Bit6:	<p>TR1: Timer 1 Run Control. 0: Timer 1 disabled. 1: Timer 1 enabled.</p>							
Bit5:	<p>TF0: Timer 0 Overflow Flag. Set by hardware when Timer 0 overflows. This flag can be cleared by software but is automatically cleared when the CPU vectors to the Timer 0 interrupt service routine. 0: No Timer 0 overflow detected. 1: Timer 0 has overflowed.</p>							
Bit4:	<p>TR0: Timer 0 Run Control. 0: Timer 0 disabled. 1: Timer 0 enabled.</p>							
Bit3:	<p>IE1: External Interrupt 1. This flag is set by hardware when an edge/level of type defined by IT1 is detected. It can be cleared by software but is automatically cleared when the CPU vectors to the External Interrupt 1 service routine if IT1 = 1. When IT1 = 0, this flag is set to '1' when /INT1 is active as defined by bit IN1PL in register IT01CF (see SFR Definition 9.11).</p>							
Bit2:	<p>IT1: Interrupt 1 Type Select. This bit selects whether the configured /INT1 interrupt will be edge or level sensitive. /INT1 is configured active low or high by the IN1PL bit in the IT01CF register (see SFR Definition 9.11). 0: /INT1 is level triggered. 1: /INT1 is edge triggered.</p>							
Bit1:	<p>IE0: External Interrupt 0. This flag is set by hardware when an edge/level of type defined by IT0 is detected. It can be cleared by software but is automatically cleared when the CPU vectors to the External Interrupt 0 service routine if IT0 = 1. When IT0 = 0, this flag is set to '1' when /INT0 is active as defined by bit IN0PL in register IT01CF (see SFR Definition 9.11).</p>							
Bit0:	<p>IT0: Interrupt 0 Type Select. This bit selects whether the configured /INT0 interrupt will be edge or level sensitive. /INT0 is configured active low or high by the IN0PL bit in register IT01CF (see SFR Definition 9.11). 0: /INT0 is level triggered. 1: /INT0 is edge triggered.</p>							

# C8051F330/1/2/3/4/5

## SFR Definition 18.2. TMOD: Timer Mode

R/W	R/W	R/W	R/W	R/W	R/W	R/W	R/W	Reset Value
GATE1	C/T1	T1M1	T1M0	GATE0	C/T0	T0M1	T0M0	00000000
Bit7	Bit6	Bit5	Bit4	Bit3	Bit2	Bit1	Bit0	SFR Address: 0x89

- Bit7: GATE1: Timer 1 Gate Control.  
 0: Timer 1 enabled when TR1 = 1 irrespective of /INT1 logic level.  
 1: Timer 1 enabled only when TR1 = 1 AND /INT1 is active as defined by bit IN1PL in register IT01CF (see SFR Definition 9.11).
- Bit6: C/T1: Counter/Timer 1 Select.  
 0: Timer Function: Timer 1 incremented by clock defined by T1M bit (CKCON.3).  
 1: Counter Function: Timer 1 incremented by high-to-low transitions on external input pin (T1).
- Bits5–4: T1M1–T1M0: Timer 1 Mode Select.  
 These bits select the Timer 1 operation mode.

T1M1	T1M0	Mode
0	0	Mode 0: 13-bit counter/timer
0	1	Mode 1: 16-bit counter/timer
1	0	Mode 2: 8-bit counter/timer with auto-reload
1	1	Mode 3: Timer 1 inactive

- Bit3: GATE0: Timer 0 Gate Control.  
 0: Timer 0 enabled when TR0 = 1 irrespective of /INT0 logic level.  
 1: Timer 0 enabled only when TR0 = 1 AND /INT0 is active as defined by bit IN0PL in register IT01CF (see SFR Definition 9.11).
- Bit2: C/T0: Counter/Timer Select.  
 0: Timer Function: Timer 0 incremented by clock defined by T0M bit (CKCON.2).  
 1: Counter Function: Timer 0 incremented by high-to-low transitions on external input pin (T0).
- Bits1–0: T0M1–T0M0: Timer 0 Mode Select.  
 These bits select the Timer 0 operation mode.

T0M1	T0M0	Mode
0	0	Mode 0: 13-bit counter/timer
0	1	Mode 1: 16-bit counter/timer
1	0	Mode 2: 8-bit counter/timer with auto-reload
1	1	Mode 3: Two 8-bit counter/timers

## SFR Definition 18.3. CKCON: Clock Control

	R/W	R/W	R/W	R/W	R/W	R/W	R/W	Reset Value	
	T3MH	T3ML	T2MH	T2ML	T1M	T0M	SCA1	SCA0	00000000
	Bit7	Bit6	Bit5	Bit4	Bit3	Bit2	Bit1	Bit0	SFR Address: 0x8E

Bit7:     **T3MH: Timer 3 High Byte Clock Select.**  
This bit selects the clock supplied to the Timer 3 high byte if Timer 3 is configured in split 8-bit timer mode. T3MH is ignored if Time 3 is in any other mode.  
0: Timer 3 high byte uses the clock defined by the T3XCLK bit in TMR3CN.  
1: Timer 3 high byte uses the system clock.

Bit6:     **T3ML: Timer 3 Low Byte Clock Select.**  
This bit selects the clock supplied to Timer 3. If Timer 3 is configured in split 8-bit timer mode, this bit selects the clock supplied to the lower 8-bit timer.  
0: Timer 3 low byte uses the clock defined by the T3XCLK bit in TMR3CN.  
1: Timer 3 low byte uses the system clock.

Bit5:     **T2MH: Timer 2 High Byte Clock Select.**  
This bit selects the clock supplied to the Timer 2 high byte if Timer 2 is configured in split 8-bit timer mode. T2MH is ignored if Timer 2 is in any other mode.  
0: Timer 2 high byte uses the clock defined by the T2XCLK bit in TMR2CN.  
1: Timer 2 high byte uses the system clock.

Bit4:     **T2ML: Timer 2 Low Byte Clock Select.**  
This bit selects the clock supplied to Timer 2. If Timer 2 is configured in split 8-bit timer mode, this bit selects the clock supplied to the lower 8-bit timer.  
0: Timer 2 low byte uses the clock defined by the T2XCLK bit in TMR2CN.  
1: Timer 2 low byte uses the system clock.

Bit3:     **T1M: Timer 1 Clock Select.**  
This select the clock source supplied to Timer 1. T1M is ignored when C/T1 is set to logic 1.  
0: Timer 1 uses the clock defined by the prescale bits, SCA1–SCA0.  
1: Timer 1 uses the system clock.

Bit2:     **T0M: Timer 0 Clock Select.**  
This bit selects the clock source supplied to Timer 0. T0M is ignored when C/T0 is set to logic 1.  
0: Counter/Timer 0 uses the clock defined by the prescale bits, SCA1–SCA0.  
1: Counter/Timer 0 uses the system clock.

Bits1–0: **SCA1–SCA0: Timer 0/1 Prescale Bits.**  
These bits control the division of the clock supplied to Timer 0 and/or Timer 1 if configured to use prescaled clock inputs.

SCA1	SCA0	Prescaled Clock
0	0	System clock divided by 12
0	1	System clock divided by 4
1	0	System clock divided by 48
1	1	External clock divided by 8

Note: External clock divided by 8 is synchronized with the system clock.

# C8051F330/1/2/3/4/5

## SFR Definition 18.4. TL0: Timer 0 Low Byte

R/W	R/W	R/W	R/W	R/W	R/W	R/W	R/W	Reset Value
								00000000
Bit7	Bit6	Bit5	Bit4	Bit3	Bit2	Bit1	Bit0	SFR Address: 0x8A

Bits 7–0: TL0: Timer 0 Low Byte.  
The TL0 register is the low byte of the 16-bit Timer 0.

## SFR Definition 18.5. TL1: Timer 1 Low Byte

R/W	R/W	R/W	R/W	R/W	R/W	R/W	R/W	Reset Value
								00000000
Bit7	Bit6	Bit5	Bit4	Bit3	Bit2	Bit1	Bit0	SFR Address: 0x8B

Bits 7–0: TL1: Timer 1 Low Byte.  
The TL1 register is the low byte of the 16-bit Timer 1.

## SFR Definition 18.6. TH0: Timer 0 High Byte

R/W	R/W	R/W	R/W	R/W	R/W	R/W	R/W	Reset Value
								00000000
Bit7	Bit6	Bit5	Bit4	Bit3	Bit2	Bit1	Bit0	SFR Address: 0x8C

Bits 7–0: TH0: Timer 0 High Byte.  
The TH0 register is the high byte of the 16-bit Timer 0.

## SFR Definition 18.7. TH1: Timer 1 High Byte

R/W	R/W	R/W	R/W	R/W	R/W	R/W	R/W	Reset Value
								00000000
Bit7	Bit6	Bit5	Bit4	Bit3	Bit2	Bit1	Bit0	SFR Address: 0x8D

Bits 7–0: TH1: Timer 1 High Byte.  
The TH1 register is the high byte of the 16-bit Timer 1.



## 18.2. Timer 2

Timer 2 is a 16-bit timer formed by two 8-bit SFRs: TMR2L (low byte) and TMR2H (high byte). Timer 2 may operate in 16-bit auto-reload mode or (split) 8-bit auto-reload mode. The T2SPLIT bit (TMR2CN.3) defines the Timer 2 operation mode.

Timer 2 may be clocked by the system clock, the system clock divided by 12, or the external oscillator source divided by 8. The external clock mode is ideal for real-time clock (RTC) functionality, where the internal oscillator drives the system clock while Timer 2 (and/or the PCA) is clocked by an external precision oscillator. Note that the external oscillator source divided by 8 is synchronized with the system clock.

### 18.2.1. 16-bit Timer with Auto-Reload

When T2SPLIT (TMR2CN.3) is zero, Timer 2 operates as a 16-bit timer with auto-reload. Timer 2 can be clocked by SYSCLK, SYSCLK divided by 12, or the external oscillator clock source divided by 8. As the 16-bit timer register increments and overflows from 0xFFFF to 0x0000, the 16-bit value in the Timer 2 reload registers (TMR2RLH and TMR2RLL) is loaded into the Timer 2 register as shown in Figure 18.4, and the Timer 2 High Byte Overflow Flag (TMR2CN.7) is set. If Timer 2 interrupts are enabled (if IE.5 is set), an interrupt will be generated on each Timer 2 overflow. Additionally, if Timer 2 interrupts are enabled and the TF2LEN bit is set (TMR2CN.5), an interrupt will be generated each time the lower 8 bits (TMR2L) overflow from 0xFF to 0x00.

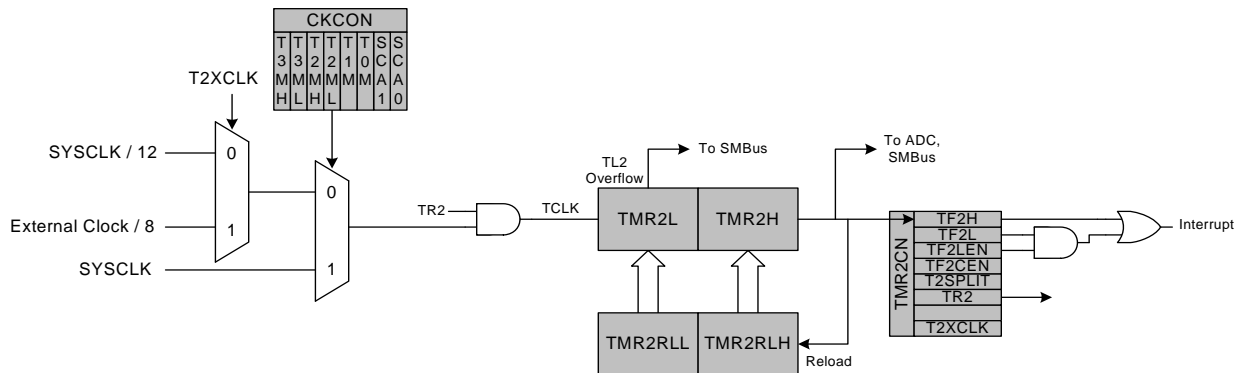

**Figure 18.4. Timer 2 16-Bit Mode Block Diagram**

# C8051F330/1/2/3/4/5

## 18.2.2. 8-bit Timers with Auto-Reload

When T2SPLIT is set, Timer 2 operates as two 8-bit timers (TMR2H and TMR2L). Both 8-bit timers operate in auto-reload mode as shown in Figure 18.5. TMR2RLL holds the reload value for TMR2L; TMR2RLH holds the reload value for TMR2H. The TR2 bit in TMR2CN handles the run control for TMR2H. TMR2L is always running when configured for 8-bit Mode.

Each 8-bit timer may be configured to use SYSCLK, SYSCLK divided by 12, or the external oscillator clock source divided by 8. The Timer 2 Clock Select bits (T2MH and T2ML in CKCON) select either SYSCLK or the clock defined by the Timer 2 External Clock Select bit (T2XCLK in TMR2CN), as follows:

T2MH	T2XCLK	TMR2H Clock Source
0	0	SYSCLK / 12
0	1	External Clock / 8
1	X	SYSCLK

T2ML	T2XCLK	TMR2L Clock Source
0	0	SYSCLK / 12
0	1	External Clock / 8
1	X	SYSCLK

The TF2H bit is set when TMR2H overflows from 0xFF to 0x00; the TF2L bit is set when TMR2L overflows from 0xFF to 0x00. When Timer 2 interrupts are enabled (IE.5), an interrupt is generated each time TMR2H overflows. If Timer 2 interrupts are enabled and TF2LEN (TMR2CN.5) is set, an interrupt is generated each time either TMR2L or TMR2H overflows. When TF2LEN is enabled, software must check the TF2H and TF2L flags to determine the source of the Timer 2 interrupt. The TF2H and TF2L interrupt flags are not cleared by hardware and must be manually cleared by software.

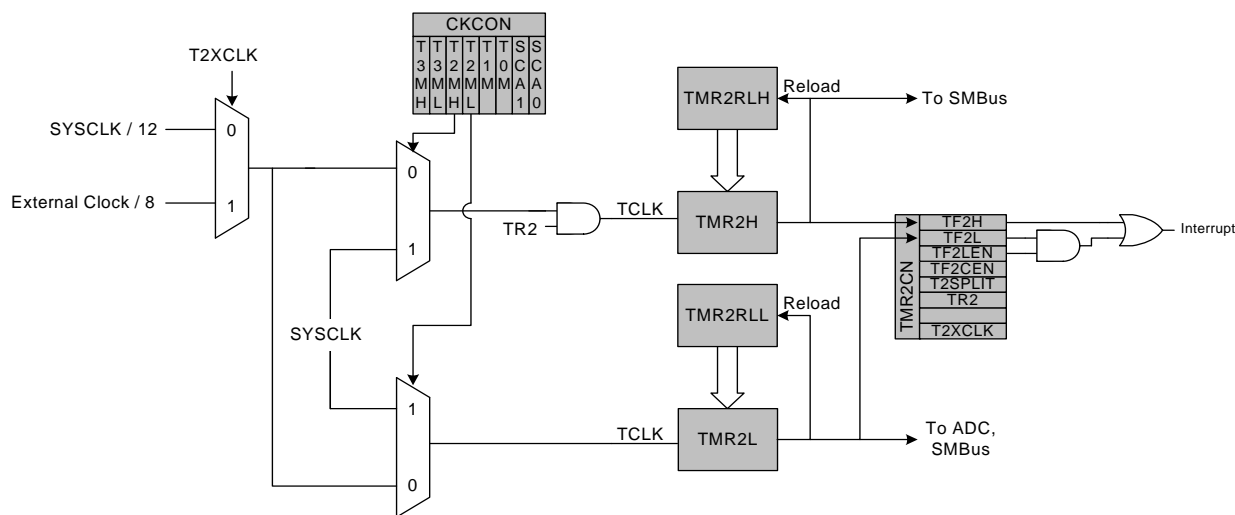

Figure 18.5. Timer 2 8-Bit Mode Block Diagram

## SFR Definition 18.8. TMR2CN: Timer 2 Control

R/W	R/W	R/W	R/W	R/W	R/W	R	R/W	Reset Value
TF2H	TF2L	TF2LEN	TF2CEN	T2SPLIT	TR2	—	T2XCLK	00000000
Bit7	Bit6	Bit5	Bit4	Bit3	Bit2	Bit1	Bit0	SFR Address: 0xC8
						(bit addressable)		

Bit7: TF2H: Timer 2 High Byte Overflow Flag.  
Set by hardware when the Timer 2 high byte overflows from 0xFF to 0x00. In 16 bit mode, this will occur when Timer 2 overflows from 0xFFFF to 0x0000. When the Timer 2 interrupt is enabled, setting this bit causes the CPU to vector to the Timer 2 interrupt service routine. TF2H is not automatically cleared by hardware and must be cleared by software.

Bit6: TF2L: Timer 2 Low Byte Overflow Flag.  
Set by hardware when the Timer 2 low byte overflows from 0xFF to 0x00. When this bit is set, an interrupt will be generated if TF2LEN is set and Timer 2 interrupts are enabled. TF2L will set when the low byte overflows regardless of the Timer 2 mode. This bit is not automatically cleared by hardware.

Bit5: TF2LEN: Timer 2 Low Byte Interrupt Enable.  
This bit enables/disables Timer 2 Low Byte interrupts. If TF2LEN is set and Timer 2 interrupts are enabled, an interrupt will be generated when the low byte of Timer 2 overflows.  
0: Timer 2 Low Byte interrupts disabled.  
1: Timer 2 Low Byte interrupts enabled.

Bit4: TF2CEN: Timer 2 Low-Frequency Oscillator Capture Enable.  
This bit enables/disables Timer 2 Low-Frequency Oscillator Capture Mode. If TF2CEN is set and Timer 2 interrupts are enabled, an interrupt will be generated on a falling edge of the low-frequency oscillator output, and the current 16-bit timer value in TMR2H:TMR2L will be copied to TMR2RLH:TMR2RLL. See [Section “13. Oscillators” on page 113](#) for more details.  
0: Timer 2 Low-Frequency Oscillator Capture disabled.  
1: Timer 2 Low-Frequency Oscillator Capture enabled.

Bit3: T2SPLIT: Timer 2 Split Mode Enable.  
When this bit is set, Timer 2 operates as two 8-bit timers with auto-reload.  
0: Timer 2 operates in 16-bit auto-reload mode.  
1: Timer 2 operates as two 8-bit auto-reload timers.

Bit2: TR2: Timer 2 Run Control.  
This bit enables/disables Timer 2. In 8-bit mode, this bit enables/disables TMR2H only; TMR2L is always enabled in this mode.  
0: Timer 2 disabled.  
1: Timer 2 enabled.

Bit1: UNUSED. Read = 0b. Write = don't care.

Bit0: T2XCLK: Timer 2 External Clock Select.  
This bit selects the external clock source for Timer 2. If Timer 2 is in 8-bit mode, this bit selects the external oscillator clock source for both timer bytes. However, the Timer 2 Clock Select bits (T2MH and T2ML in register CKCON) may still be used to select between the external clock and the system clock for either timer.  
0: Timer 2 external clock selection is the system clock divided by 12.  
1: Timer 2 external clock selection is the external clock divided by 8. Note that the external oscillator source divided by 8 is synchronized with the system clock.

# C8051F330/1/2/3/4/5

## SFR Definition 18.9. TMR2RLL: Timer 2 Reload Register Low Byte

R/W	R/W	R/W	R/W	R/W	R/W	R/W	R/W	Reset Value
								00000000
Bit7	Bit6	Bit5	Bit4	Bit3	Bit2	Bit1	Bit0	SFR Address: 0xCA

Bits 7–0: TMR2RLL: Timer 2 Reload Register Low Byte.  
TMR2RLL holds the low byte of the reload value for Timer 2.

## SFR Definition 18.10. TMR2RLH: Timer 2 Reload Register High Byte

R/W	R/W	R/W	R/W	R/W	R/W	R/W	R/W	Reset Value
								00000000
Bit7	Bit6	Bit5	Bit4	Bit3	Bit2	Bit1	Bit0	SFR Address: 0xCB

Bits 7–0: TMR2RLH: Timer 2 Reload Register High Byte.  
The TMR2RLH holds the high byte of the reload value for Timer 2.

## SFR Definition 18.11. TMR2L: Timer 2 Low Byte

R/W	R/W	R/W	R/W	R/W	R/W	R/W	R/W	Reset Value
								00000000
Bit7	Bit6	Bit5	Bit4	Bit3	Bit2	Bit1	Bit0	SFR Address: 0xCC

Bits 7–0: TMR2L: Timer 2 Low Byte.  
In 16-bit mode, the TMR2L register contains the low byte of the 16-bit Timer 2. In 8-bit mode, TMR2L contains the 8-bit low byte timer value.

## SFR Definition 18.12. TMR2H Timer 2 High Byte

R/W	R/W	R/W	R/W	R/W	R/W	R/W	R/W	Reset Value
								00000000
Bit7	Bit6	Bit5	Bit4	Bit3	Bit2	Bit1	Bit0	SFR Address: 0xCD

Bits 7–0: TMR2H: Timer 2 High Byte.  
In 16-bit mode, the TMR2H register contains the high byte of the 16-bit Timer 2. In 8-bit mode, TMR2H contains the 8-bit high byte timer value.

## 18.3. Timer 3

Timer 3 is a 16-bit timer formed by two 8-bit SFRs: TMR3L (low byte) and TMR3H (high byte). Timer 3 may operate in 16-bit auto-reload mode or (split) 8-bit auto-reload mode. The T3SPLIT bit (TMR3CN.3) defines the Timer 3 operation mode.

Timer 3 may be clocked by the system clock, the system clock divided by 12, or the external oscillator source divided by 8. The external clock mode is ideal for real-time clock (RTC) functionality, where the internal oscillator drives the system clock while Timer 3 (and/or the PCA) is clocked by an external precision oscillator. Note that the external oscillator source divided by 8 is synchronized with the system clock.

### 18.3.1. 16-bit Timer with Auto-Reload

When T3SPLIT (TMR3CN.3) is zero, Timer 3 operates as a 16-bit timer with auto-reload. Timer 3 can be clocked by SYSCLK, SYSCLK divided by 12, or the external oscillator clock source divided by 8. As the 16-bit timer register increments and overflows from 0xFFFF to 0x0000, the 16-bit value in the Timer 3 reload registers (TMR3RLH and TMR3RLL) is loaded into the Timer 3 register as shown in Figure 18.6, and the Timer 3 High Byte Overflow Flag (TMR3CN.7) is set. If Timer 3 interrupts are enabled (if EIE1.7 is set), an interrupt will be generated on each Timer 3 overflow. Additionally, if Timer 3 interrupts are enabled and the TF3LEN bit is set (TMR3CN.5), an interrupt will be generated each time the lower 8 bits (TMR3L) overflow from 0xFF to 0x00.

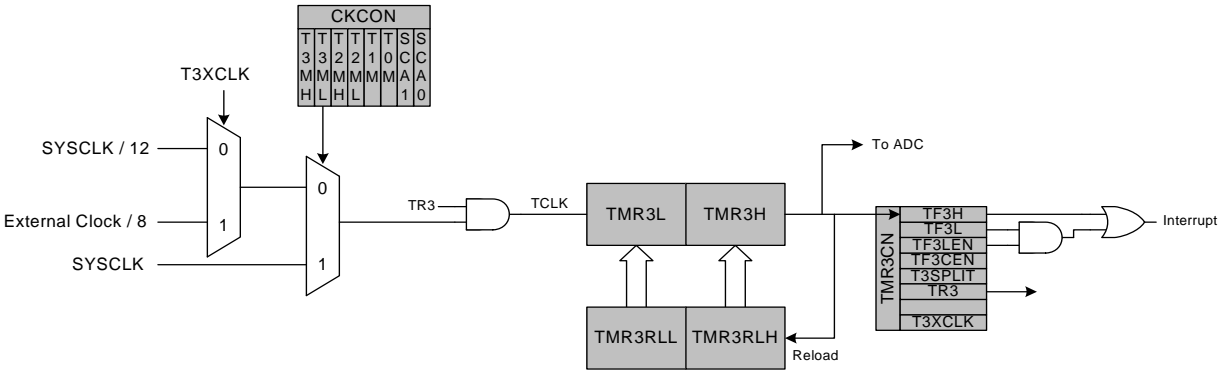

Figure 18.6. Timer 3 16-Bit Mode Block Diagram

# C8051F330/1/2/3/4/5

## 18.3.2. 8-bit Timers with Auto-Reload

When T3SPLIT is set, Timer 3 operates as two 8-bit timers (TMR3H and TMR3L). Both 8-bit timers operate in auto-reload mode as shown in Figure 18.7. TMR3RLL holds the reload value for TMR3L; TMR3RLH holds the reload value for TMR3H. The TR3 bit in TMR3CN handles the run control for TMR3H. TMR3L is always running when configured for 8-bit Mode.

Each 8-bit timer may be configured to use SYSCLK, SYSCLK divided by 12, or the external oscillator clock source divided by 8. The Timer 3 Clock Select bits (T3MH and T3ML in CKCON) select either SYSCLK or the clock defined by the Timer 3 External Clock Select bit (T3XCLK in TMR3CN), as follows:

T3MH	T3XCLK	TMR3H Clock Source
0	0	SYSCLK / 12
0	1	External Clock / 8
1	X	SYSCLK

T3ML	T3XCLK	TMR3L Clock Source
0	0	SYSCLK / 12
0	1	External Clock / 8
1	X	SYSCLK

The TF3H bit is set when TMR3H overflows from 0xFF to 0x00; the TF3L bit is set when TMR3L overflows from 0xFF to 0x00. When Timer 3 interrupts are enabled, an interrupt is generated each time TMR3H overflows. If Timer 3 interrupts are enabled and TF3LEN (TMR3CN.5) is set, an interrupt is generated each time either TMR3L or TMR3H overflows. When TF3LEN is enabled, software must check the TF3H and TF3L flags to determine the source of the Timer 3 interrupt. The TF3H and TF3L interrupt flags are not cleared by hardware and must be manually cleared by software.

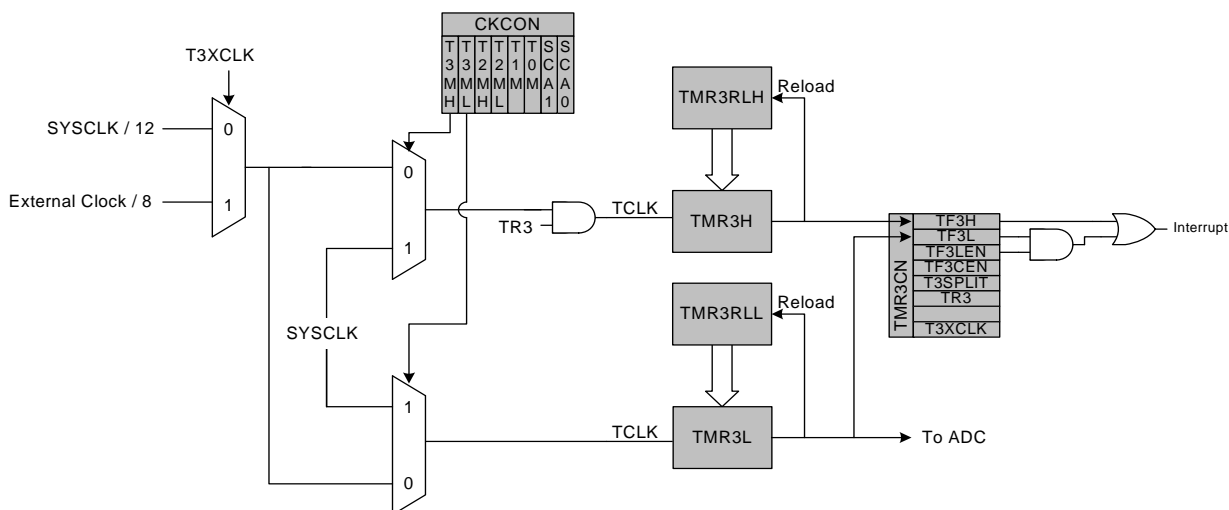

Figure 18.7. Timer 3 8-Bit Mode Block Diagram

## SFR Definition 18.13. TMR3CN: Timer 3 Control

R/W	R/W	R/W	R/W	R/W	R/W	R	R/W	Reset Value
TF3H	TF3L	TF3LEN	TF3CEN	T3SPLIT	TR3	—	T3XCLK	00000000
Bit7	Bit6	Bit5	Bit4	Bit3	Bit2	Bit1	Bit0	SFR Address: 0x91

Bit7: TF3H: Timer 3 High Byte Overflow Flag.  
Set by hardware when the Timer 3 high byte overflows from 0xFF to 0x00. In 16 bit mode, this will occur when Timer 3 overflows from 0xFFFF to 0x0000. When the Timer 3 interrupt is enabled, setting this bit causes the CPU to vector to the Timer 3 interrupt service routine. TF3H is not automatically cleared by hardware and must be cleared by software.

Bit6: TF3L: Timer 3 Low Byte Overflow Flag.  
Set by hardware when the Timer 3 low byte overflows from 0xFF to 0x00. When this bit is set, an interrupt will be generated if TF3LEN is set and Timer 3 interrupts are enabled. TF3L will set when the low byte overflows regardless of the Timer 3 mode. This bit is not automatically cleared by hardware.

Bit5: TF3LEN: Timer 3 Low Byte Interrupt Enable.  
This bit enables/disables Timer 3 Low Byte interrupts. If TF3LEN is set and Timer 3 interrupts are enabled, an interrupt will be generated when the low byte of Timer 3 overflows.  
0: Timer 3 Low Byte interrupts disabled.  
1: Timer 3 Low Byte interrupts enabled.

Bit4: TF3CEN: Timer 3 Low-Frequency Oscillator Capture Enable.  
This bit enables/disables Timer 3 Low-Frequency Oscillator Capture Mode. If TF3CEN is set and Timer 3 interrupts are enabled, an interrupt will be generated on a rising edge of the low-frequency oscillator output, and the current 16-bit timer value in TMR3H:TMR3L will be copied to TMR3RLH:TMR3RLL. See [Section “13. Oscillators” on page 113](#) for more details.  
0: Timer 3 Low-Frequency Oscillator Capture disabled.  
1: Timer 3 Low-Frequency Oscillator Capture enabled.

Bit3: T3SPLIT: Timer 3 Split Mode Enable.  
When this bit is set, Timer 3 operates as two 8-bit timers with auto-reload.  
0: Timer 3 operates in 16-bit auto-reload mode.  
1: Timer 3 operates as two 8-bit auto-reload timers.

Bit2: TR3: Timer 3 Run Control.  
This bit enables/disables Timer 3. In 8-bit mode, this bit enables/disables TMR3H only; TMR3L is always enabled in this mode.  
0: Timer 3 disabled.  
1: Timer 3 enabled.

Bit1: UNUSED. Read = 0b. Write = don't care.

Bit0: T3XCLK: Timer 3 External Clock Select.  
This bit selects the external clock source for Timer 3. If Timer 3 is in 8-bit mode, this bit selects the external oscillator clock source for both timer bytes. However, the Timer 3 Clock Select bits (T3MH and T3ML in register CKCON) may still be used to select between the external clock and the system clock for either timer.  
0: Timer 3 external clock selection is the system clock divided by 12.  
1: Timer 3 external clock selection is the external clock divided by 8. Note that the external oscillator source divided by 8 is synchronized with the system clock.

# C8051F330/1/2/3/4/5

## SFR Definition 18.14. TMR3RLL: Timer 3 Reload Register Low Byte

R/W	R/W	R/W	R/W	R/W	R/W	R/W	R/W	Reset Value
								00000000
Bit7	Bit6	Bit5	Bit4	Bit3	Bit2	Bit1	Bit0	SFR Address:
								0x92

Bits 7–0: TMR3RLL: Timer 3 Reload Register Low Byte.  
TMR3RLL holds the low byte of the reload value for Timer 3.

## SFR Definition 18.15. TMR3RLH: Timer 3 Reload Register High Byte

R/W	R/W	R/W	R/W	R/W	R/W	R/W	R/W	Reset Value
								00000000
Bit7	Bit6	Bit5	Bit4	Bit3	Bit2	Bit1	Bit0	SFR Address:
								0x93

Bits 7–0: TMR3RLH: Timer 3 Reload Register High Byte.  
The TMR3RLH holds the high byte of the reload value for Timer 3.

## SFR Definition 18.16. TMR3L: Timer 3 Low Byte

R/W	R/W	R/W	R/W	R/W	R/W	R/W	R/W	Reset Value
								00000000
Bit7	Bit6	Bit5	Bit4	Bit3	Bit2	Bit1	Bit0	SFR Address:
								0x94

Bits 7–0: TMR3L: Timer 3 Low Byte.  
In 16-bit mode, the TMR3L register contains the low byte of the 16-bit Timer 3. In 8-bit mode, TMR3L contains the 8-bit low byte timer value.

## SFR Definition 18.17. TMR3H Timer 3 High Byte

R/W	R/W	R/W	R/W	R/W	R/W	R/W	R/W	Reset Value
								00000000
Bit7	Bit6	Bit5	Bit4	Bit3	Bit2	Bit1	Bit0	SFR Address:
								0x95

Bits 7–0: TMR3H: Timer 3 High Byte.  
In 16-bit mode, the TMR3H register contains the high byte of the 16-bit Timer 3. In 8-bit mode, TMR3H contains the 8-bit high byte timer value.



## 19. Programmable Counter Array

The Programmable Counter Array (PCA0) provides enhanced timer functionality while requiring less CPU intervention than the standard 8051 counter/timers. The PCA consists of a dedicated 16-bit counter/timer and three 16-bit capture/compare modules. Each capture/compare module has its own associated I/O line (CEXn) which is routed through the Crossbar to Port I/O when enabled (See [Section “14.1. Priority Crossbar Decoder” on page 125](#) for details on configuring the Crossbar). The counter/timer is driven by a programmable timebase that can select between six sources: system clock, system clock divided by four, system clock divided by twelve, the external oscillator clock source divided by 8, Timer 0 overflow, or an external clock signal on the ECI input pin. Each capture/compare module may be configured to operate independently in one of six modes: Edge-Triggered Capture, Software Timer, High-Speed Output, Frequency Output, 8-Bit PWM, or 16-Bit PWM (each mode is described in [Section “19.2. Capture/Compare Modules” on page 195](#)). The external oscillator clock option is ideal for real-time clock (RTC) functionality, allowing the PCA to be clocked by a precision external oscillator while the internal oscillator drives the system clock. The PCA is configured and controlled through the system controller's Special Function Registers. The PCA block diagram is shown in Figure 19.1

**Important Note:** The PCA Module 2 may be used as a watchdog timer (WDT), and is enabled in this mode following a system reset. **Access to certain PCA registers is restricted while WDT mode is enabled.** See [Section 19.3](#) for details.

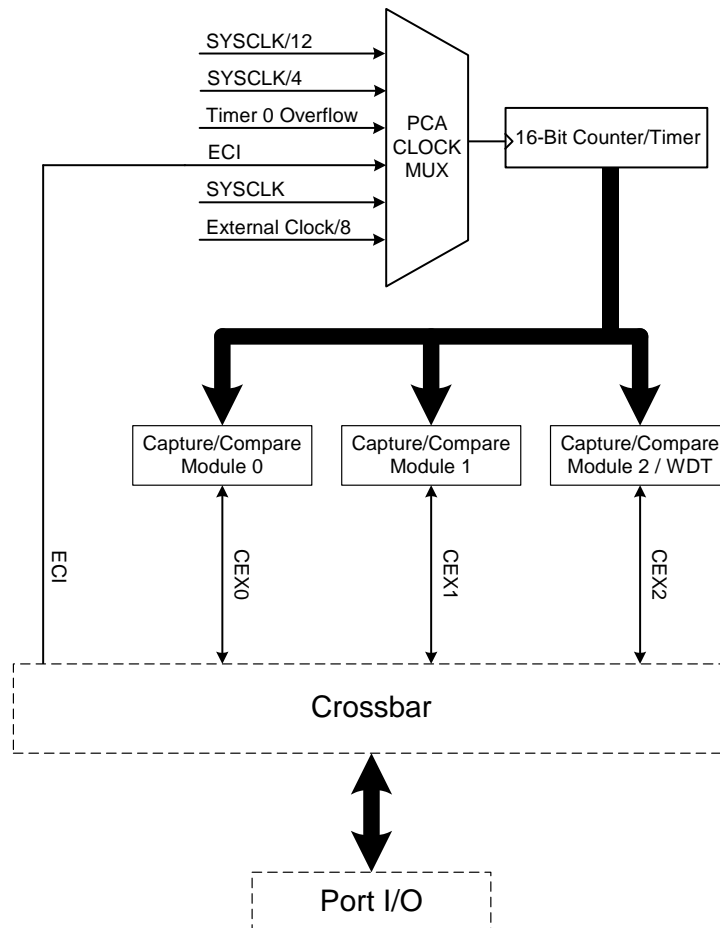

Figure 19.1. PCA Block Diagram

# C8051F330/1/2/3/4/5

## 19.1. PCA Counter/Timer

The 16-bit PCA counter/timer consists of two 8-bit SFRs: PCA0L and PCA0H. PCA0H is the high byte (MSB) of the 16-bit counter/timer and PCA0L is the low byte (LSB). Reading PCA0L automatically latches the value of PCA0H into a “snapshot” register; the following PCA0H read accesses this “snapshot” register. **Reading the PCA0L Register first guarantees an accurate reading of the entire 16-bit PCA0 counter.** Reading PCA0H or PCA0L does not disturb the counter operation. The CPS2–CPS0 bits in the PCA0MD register select the timebase for the counter/timer as shown in Table 19.1.

When the counter/timer overflows from 0xFFFF to 0x0000, the Counter Overflow Flag (CF) in PCA0MD is set to logic 1 and an interrupt request is generated if CF interrupts are enabled. Setting the ECF bit in PCA0MD to logic 1 enables the CF flag to generate an interrupt request. The CF bit is not automatically cleared by hardware when the CPU vectors to the interrupt service routine, and must be cleared by software (Note: PCA0 interrupts must be globally enabled before CF interrupts are recognized. PCA0 interrupts are globally enabled by setting the EA bit (IE.7) and the EPCA0 bit in EIE1 to logic 1). Clearing the CIDL bit in the PCA0MD register allows the PCA to continue normal operation while the CPU is in Idle mode.

**Table 19.1. PCA Timebase Input Options**

CPS2	CPS1	CPS0	Timebase
0	0	0	System clock divided by 12
0	0	1	System clock divided by 4
0	1	0	Timer 0 overflow
0	1	1	High-to-low transitions on ECI (max rate = system clock divided by 4)
1	0	0	System clock
1	0	1	External oscillator source divided by 8*

\*Note: External oscillator source divided by 8 is synchronized with the system clock.

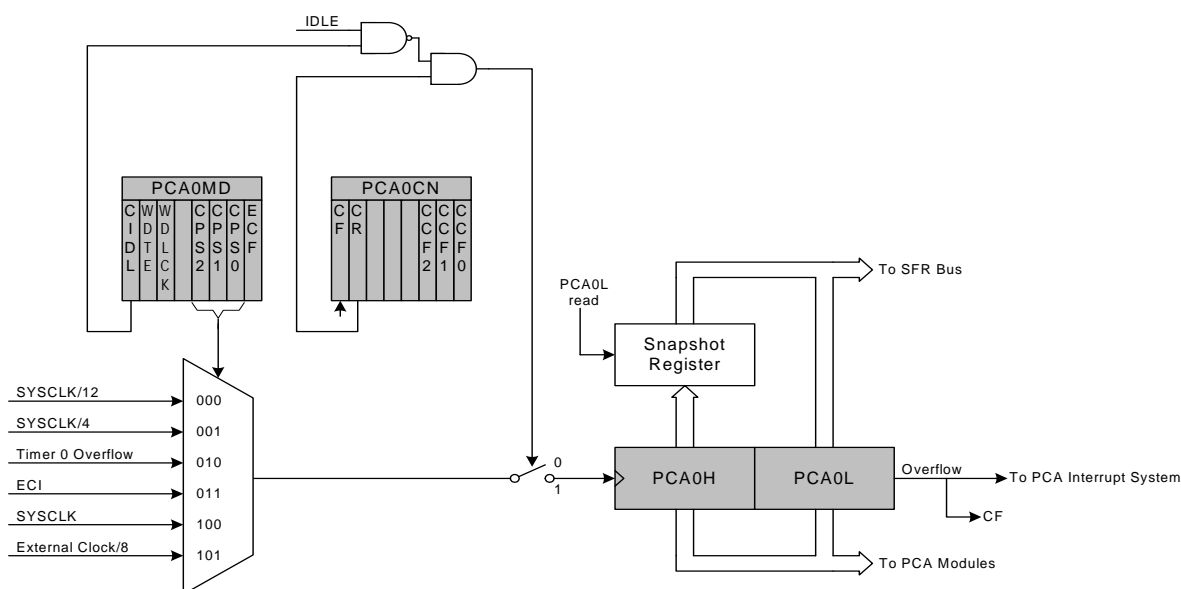

**Figure 19.2. PCA Counter/Timer Block Diagram**

## 19.2. Capture/Compare Modules

Each module can be configured to operate independently in one of six operation modes: Edge-triggered Capture, Software Timer, High Speed Output, Frequency Output, 8-Bit Pulse Width Modulator, or 16-Bit Pulse Width Modulator. Each module has Special Function Registers (SFRs) associated with it in the CIP-51 system controller. These registers are used to exchange data with a module and configure the module's mode of operation.

Table 19.2 summarizes the bit settings in the PCA0CPMn registers used to select the PCA capture/compare module's operating modes. Setting the ECCFn bit in a PCA0CPMn register enables the module's CCFn interrupt. Note: PCA0 interrupts must be globally enabled before individual CCFn interrupts are recognized. PCA0 interrupts are globally enabled by setting the EA bit and the EPCA0 bit to logic 1. See Figure 19.3 for details on the PCA interrupt configuration.

**Table 19.2. PCA0CPM Register Settings for PCA Capture/Compare Modules**

PWM16	ECOM	CAPP	CAPN	MAT	TOG	PWM	ECCF	Operation Mode
X	X	1	0	0	0	0	X	Capture triggered by positive edge on CEXn
X	X	0	1	0	0	0	X	Capture triggered by negative edge on CEXn
X	X	1	1	0	0	0	X	Capture triggered by transition on CEXn
X	1	0	0	1	0	0	X	Software Timer
X	1	0	0	1	1	0	X	High Speed Output
X	1	0	0	X	1	1	X	Frequency Output
0	1	0	0	X	0	1	X	8-Bit Pulse Width Modulator
1	1	0	0	X	0	1	X	16-Bit Pulse Width Modulator

**Note:** X = Don't Care.

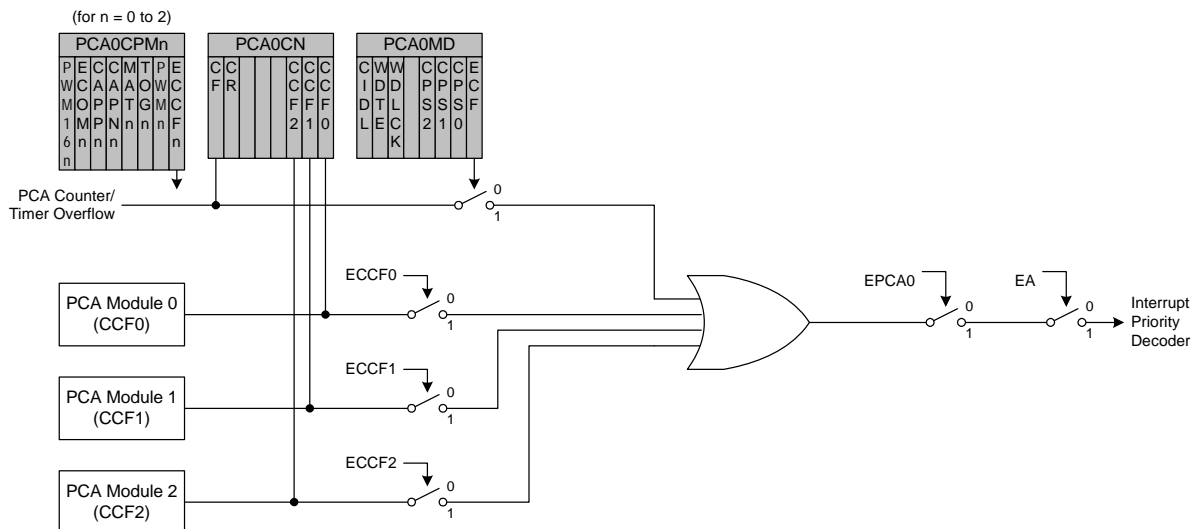

**Figure 19.3. PCA Interrupt Block Diagram**

## 19.2.1. Edge-triggered Capture Mode

In this mode, a valid transition on the CEX<sub>n</sub> pin causes the PCA to capture the value of the PCA counter/timer and load it into the corresponding module's 16-bit capture/compare register (PCA0CPL<sub>n</sub> and PCA0CPH<sub>n</sub>). The CAPP<sub>n</sub> and CAPN<sub>n</sub> bits in the PCA0CPM<sub>n</sub> register are used to select the type of transition that triggers the capture: low-to-high transition (positive edge), high-to-low transition (negative edge), or either transition (positive or negative edge). When a capture occurs, the Capture/Compare Flag (CCF<sub>n</sub>) in PCA0CN is set to logic 1 and an interrupt request is generated if CCF interrupts are enabled. The CCF<sub>n</sub> bit is not automatically cleared by hardware when the CPU vectors to the interrupt service routine, and must be cleared by software. If both CAPP<sub>n</sub> and CAPN<sub>n</sub> bits are set to logic 1, then the state of the Port pin associated with CEX<sub>n</sub> can be read directly to determine whether a rising-edge or falling-edge caused the capture.

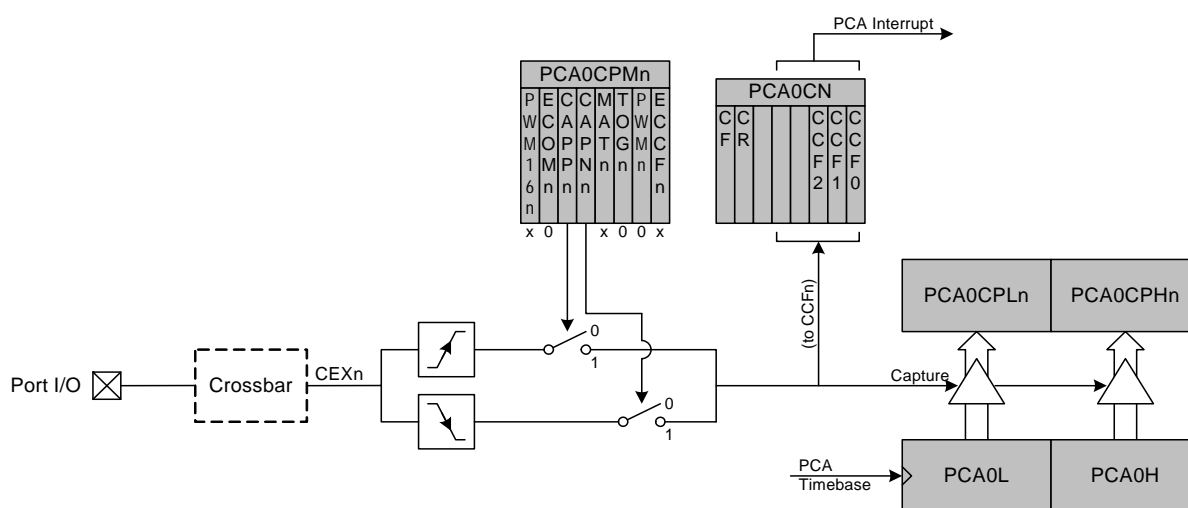

**Figure 19.4. PCA Capture Mode Diagram**

**Note:** The CEX<sub>n</sub> input signal must remain high or low for at least 2 system clock cycles to be recognized by the hardware.

## 19.2.2. Software Timer (Compare) Mode

In Software Timer mode, the PCA counter/timer value is compared to the module's 16-bit capture/compare register (PCA0CPHn and PCA0CPLn). When a match occurs, the Capture/Compare Flag (CCFn) in PCA0CN is set to logic 1 and an interrupt request is generated if CCF interrupts are enabled. The CCFn bit is not automatically cleared by hardware when the CPU vectors to the interrupt service routine, and must be cleared by software. Setting the ECOMn and MATn bits in the PCA0CPMn register enables Software Timer mode.

**Important Note About Capture/Compare Registers:** When writing a 16-bit value to the PCA0 Capture/Compare registers, the low byte should always be written first. Writing to PCA0CPLn clears the ECOMn bit to '0'; writing to PCA0CPHn sets ECOMn to '1'.

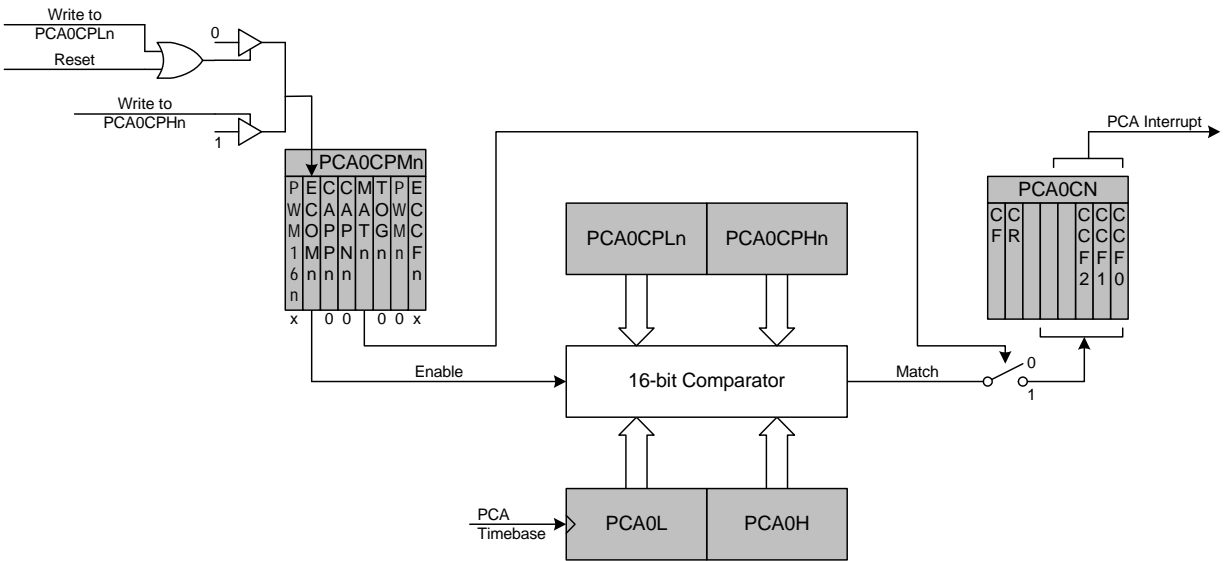

Figure 19.5. PCA Software Timer Mode Diagram



## 19.2.4. Frequency Output Mode

Frequency Output Mode produces a programmable-frequency square wave on the module's associated CEXn pin. The capture/compare module high byte holds the number of PCA clocks to count before the output is toggled. The frequency of the square wave is then defined by Equation 19.3.

$$F_{CEXn} = \frac{F_{PCA}}{2 \times PCA0CPHn}$$

Note: A value of 0x00 in the PCA0CPHn register is equal to 256 for this equation.

### Equation 19.3. Square Wave Frequency Output

Where  $F_{PCA}$  is the frequency of the clock selected by the CPS2–0 bits in the PCA mode register, PCA0MD. The lower byte of the capture/compare module is compared to the PCA counter low byte; on a match, CEXn is toggled and the offset held in the high byte is added to the matched value in PCA0CPLn. Frequency Output Mode is enabled by setting the ECOMn, TOGn, and PWMn bits in the PCA0CPMn register.

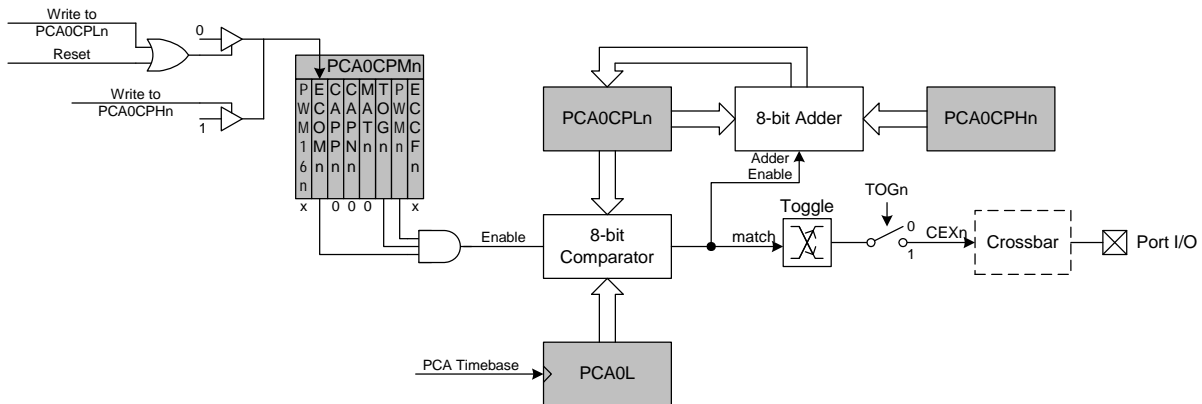

Figure 19.7. PCA Frequency Output Mode

## 19.2.5. 8-Bit Pulse Width Modulator Mode

Each module can be used independently to generate a pulse width modulated (PWM) output on its associated CEXn pin. The frequency of the output is dependent on the timebase for the PCA counter/timer. The duty cycle of the PWM output signal is varied using the module's PCA0CPLn capture/compare register. When the value in the low byte of the PCA counter/timer (PCA0L) is equal to the value in PCA0CPLn, the output on the CEXn pin will be set. When the count value in PCA0L overflows, the CEXn output will be reset (see Figure 19.8). Also, when the counter/timer low byte (PCA0L) overflows from 0xFF to 0x00, PCA0CPLn is reloaded automatically with the value stored in the module's capture/compare high byte (PCA0CPHn) without software intervention. Setting the ECOMn and PWMn bits in the PCA0CPMn register enables 8-Bit Pulse Width Modulator mode. The duty cycle for 8-Bit PWM Mode is given by Equation 19.4.

**Important Note About Capture/Compare Registers:** When writing a 16-bit value to the PCA0 Capture/Compare registers, the low byte should always be written first. Writing to PCA0CPLn clears the ECOMn bit to '0'; writing to PCA0CPHn sets ECOMn to '1'.

$$DutyCycle = \frac{(256 - PCA0CPHn)}{256}$$

**Equation 19.4. 8-Bit PWM Duty Cycle**

Using Equation 19.4, the largest duty cycle is 100% (PCA0CPHn = 0), and the smallest duty cycle is 0.39% (PCA0CPHn = 0xFF). A 0% duty cycle may be generated by clearing the ECOMn bit to '0'.

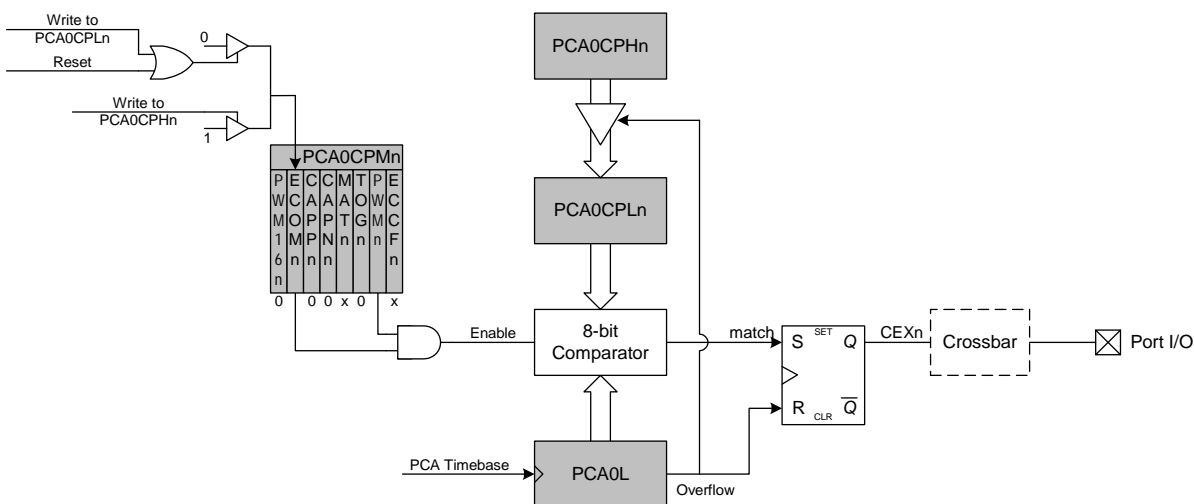

**Figure 19.8. PCA 8-Bit PWM Mode Diagram**



## 19.2.6. 16-Bit Pulse Width Modulator Mode

A PCA module may also be operated in 16-Bit PWM mode. In this mode, the 16-bit capture/compare module defines the number of PCA clocks for the low time of the PWM signal. When the PCA counter matches the module contents, the output on CEXn is asserted high; when the counter overflows, CEXn is asserted low. To output a varying duty cycle, new value writes should be synchronized with PCA CCFn match interrupts. 16-Bit PWM Mode is enabled by setting the ECOMn, PWMn, and PWM16n bits in the PCA0CPMn register. For a varying duty cycle, match interrupts should be enabled (ECCFn = 1 AND MATn = 1) to help synchronize the capture/compare register writes. The duty cycle for 16-Bit PWM Mode is given by Equation 19.5.

**Important Note About Capture/Compare Registers:** When writing a 16-bit value to the PCA0 Capture/Compare registers, the low byte should always be written first. Writing to PCA0CPLn clears the ECOMn bit to '0'; writing to PCA0CPHn sets ECOMn to '1'.

$$DutyCycle = \frac{(65536 - PCA0CPn)}{65536}$$

**Equation 19.5. 16-Bit PWM Duty Cycle**

Using Equation 19.5, the largest duty cycle is 100% (PCA0CPn = 0), and the smallest duty cycle is 0.0015% (PCA0CPn = 0xFFFF). A 0% duty cycle may be generated by clearing the ECOMn bit to '0'.

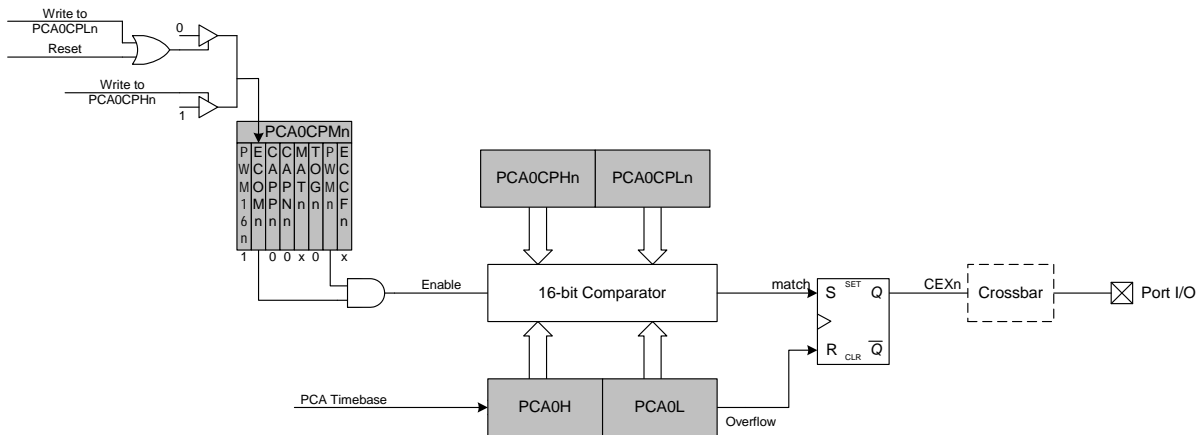

**Figure 19.9. PCA 16-Bit PWM Mode**

## 19.3. Watchdog Timer Mode

A programmable watchdog timer (WDT) function is available through the PCA Module 2. The WDT is used to generate a reset if the time between writes to the WDT update register (PCA0CPH2) exceed a specified limit. The WDT can be configured and enabled/disabled as needed by software.

With the WDTE bit set in the PCA0MD register, Module 2 operates as a watchdog timer (WDT). The Module 2 high byte is compared to the PCA counter high byte; the Module 2 low byte holds the offset to be used when WDT updates are performed. **The Watchdog Timer is enabled on reset. Writes to some PCA registers are restricted while the Watchdog Timer is enabled.**

# C8051F330/1/2/3/4/5

## 19.3.1. Watchdog Timer Operation

While the WDT is enabled:

- PCA counter is forced on.
- Writes to PCA0L and PCA0H are not allowed.
- PCA clock source bits (CPS2–CPS0) are frozen.
- PCA Idle control bit (CIDL) is frozen.
- Module 2 is forced into software timer mode.
- Writes to the Module 2 mode register (PCA0CPM2) are disabled.

While the WDT is enabled, writes to the CR bit will not change the PCA counter state; the counter will run until the WDT is disabled. The PCA counter run control (CR) will read zero if the WDT is enabled but user software has not enabled the PCA counter. If a match occurs between PCA0CPH2 and PCA0H while the WDT is enabled, a reset will be generated. To prevent a WDT reset, the WDT may be updated with a write of any value to PCA0CPH2. Upon a PCA0CPH2 write, PCA0H plus the offset held in PCA0CPL2 is loaded into PCA0CPH2 (See Figure 19.10).

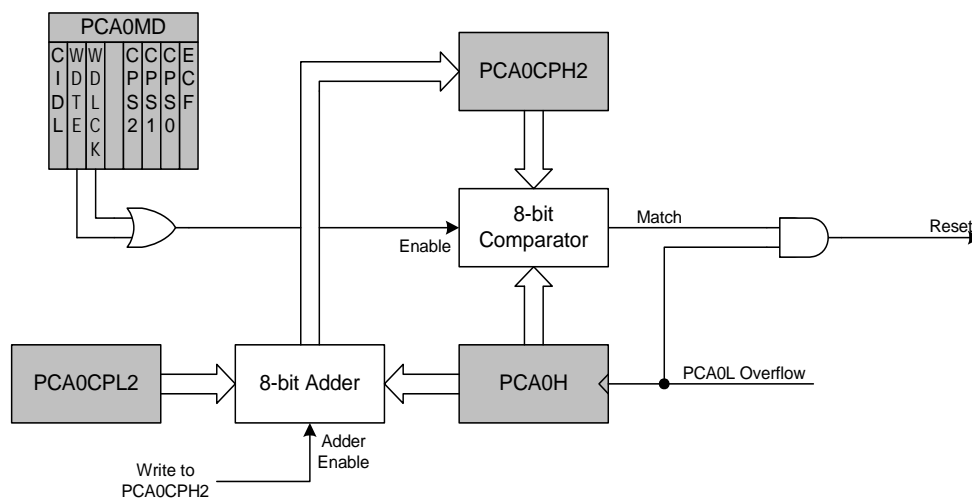

Figure 19.10. PCA Module 2 with Watchdog Timer Enabled

---

Note that the 8-bit offset held in PCA0CPH2 is compared to the upper byte of the 16-bit PCA counter. This offset value is the number of PCA0L overflows before a reset. Up to 256 PCA clocks may pass before the first PCA0L overflow occurs, depending on the value of the PCA0L when the update is performed. The total offset is then given (in PCA clocks) by Equation 19.6, where PCA0L is the value of the PCA0L register at the time of the update.

$$\text{Offset} = (256 \times \text{PCA0CPL2}) + (256 - \text{PCA0L})$$

### Equation 19.6. Watchdog Timer Offset in PCA Clocks

The WDT reset is generated when PCA0L overflows while there is a match between PCA0CPH2 and PCA0H. Software may force a WDT reset by writing a '1' to the CCF2 flag (PCA0CN.2) while the WDT is enabled.

#### 19.3.2. Watchdog Timer Usage

To configure the WDT, perform the following tasks:

- Disable the WDT by writing a '0' to the WDTE bit.
- Select the desired PCA clock source (with the CPS2–CPS0 bits).
- Load PCA0CPL2 with the desired WDT update offset value.
- Configure the PCA Idle mode (set CIDL if the WDT should be suspended while the CPU is in Idle mode).
- Enable the WDT by setting the WDTE bit to '1'.
- Write a value to PCA0CPH2 to reload the WDT.

The PCA clock source and Idle mode select cannot be changed while the WDT is enabled. The watchdog timer is enabled by setting the WDTE or WDLCK bits in the PCA0MD register. When WDLCK is set, the WDT cannot be disabled until the next system reset. If WDLCK is not set, the WDT is disabled by clearing the WDTE bit.

The WDT is enabled following any reset. The PCA0 counter clock defaults to the system clock divided by 12, PCA0L defaults to 0x00, and PCA0CPL2 defaults to 0x00. Using Equation 19.6, this results in a WDT timeout interval of 256 PCA clock cycles, or 3072 system clock cycles. Table 19.4 lists some example timeout intervals for typical system clocks.

**Table 19.4. Watchdog Timer Timeout Intervals<sup>1</sup>**

System Clock (Hz)	PCA0CPL2	Timeout Interval (ms)
24,500,000	255	32.1
24,500,000	128	16.2
24,500,000	32	4.1
18,432,000	255	42.7
18,432,000	128	21.5
18,432,000	32	5.5
11,059,200	255	71.1
11,059,200	128	35.8
11,059,200	32	9.2
3,062,500 <sup>2</sup>	255	257
3,062,500 <sup>2</sup>	128	129.5
3,062,500 <sup>2</sup>	32	33.1
32,000	255	24576
32,000	128	12384
32,000	32	3168

**Notes:**

1. Assumes SYSCLK/12 as the PCA clock source, and a PCA0L value of 0x00 at the update time.
2. Internal SYSCLK reset frequency = Internal Oscillator divided by 8.

## 19.5. Register Descriptions for PCA

Following are detailed descriptions of the special function registers related to the operation of the PCA.

## SFR Definition 19.1. PCA0CN: PCA Control

R/W	R/W	R	R	R	R/W	R/W	R/W	Reset Value
CF	CR	-	-	-	CCF2	CCF1	CCF0	00000000
Bit7	Bit6	Bit5	Bit4	Bit3	Bit2	Bit1	Bit0	Bit Addressable
SFR Address: 0xD8								
Bit7:	<p><b>CF: PCA Counter/Timer Overflow Flag.</b> Set by hardware when the PCA Counter/Timer overflows from 0xFFFF to 0x0000. When the Counter/Timer Overflow (CF) interrupt is enabled, setting this bit causes the CPU to vector to the PCA interrupt service routine. This bit is not automatically cleared by hardware and must be cleared by software.</p>							
Bit6:	<p><b>CR: PCA Counter/Timer Run Control.</b> This bit enables/disables the PCA Counter/Timer. 0: PCA Counter/Timer disabled. 1: PCA Counter/Timer enabled.</p>							
Bits5–3:	<p><b>UNUSED.</b> Read = 000b, Write = don't care.</p>							
Bit2:	<p><b>CCF2: PCA Module 2 Capture/Compare Flag.</b> This bit is set by hardware when a match or capture occurs. When the CCF2 interrupt is enabled, setting this bit causes the CPU to vector to the PCA interrupt service routine. This bit is not automatically cleared by hardware and must be cleared by software.</p>							
Bit1:	<p><b>CCF1: PCA Module 1 Capture/Compare Flag.</b> This bit is set by hardware when a match or capture occurs. When the CCF1 interrupt is enabled, setting this bit causes the CPU to vector to the PCA interrupt service routine. This bit is not automatically cleared by hardware and must be cleared by software.</p>							
Bit0:	<p><b>CCF0: PCA Module 0 Capture/Compare Flag.</b> This bit is set by hardware when a match or capture occurs. When the CCF0 interrupt is enabled, setting this bit causes the CPU to vector to the PCA interrupt service routine. This bit is not automatically cleared by hardware and must be cleared by software.</p>							

# C8051F330/1/2/3/4/5

## SFR Definition 19.2. PCA0MD: PCA Mode

R/W	R/W	R/W	R	R/W	R/W	R/W	R/W	Reset Value
CIDL	WDTE	WDLCK	—	CPS2	CPS1	CPS0	ECF	01000000
Bit7	Bit6	Bit5	Bit4	Bit3	Bit2	Bit1	Bit0	

SFR Address: 0xD9

- Bit7:** CIDL: PCA Counter/Timer Idle Control.  
Specifies PCA behavior when CPU is in Idle Mode.  
0: PCA continues to function normally while the system controller is in Idle Mode.  
1: PCA operation is suspended while the system controller is in Idle Mode.
- Bit6:** WDTE: Watchdog Timer Enable  
If this bit is set, PCA Module 2 is used as the watchdog timer.  
0: Watchdog Timer disabled.  
1: PCA Module 2 enabled as Watchdog Timer.
- Bit5:** WDLCK: Watchdog Timer Lock  
This bit locks/unlocks the Watchdog Timer Enable. When WDLCK is set, the Watchdog Timer may not be disabled until the next system reset.  
0: Watchdog Timer Enable unlocked.  
1: Watchdog Timer Enable locked.
- Bit4:** UNUSED. Read = 0b, Write = don't care.
- Bits3–1:** CPS2–CPS0: PCA Counter/Timer Pulse Select.  
These bits select the timebase source for the PCA counter.

CPS2	CPS1	CPS0	Timebase
0	0	0	System clock divided by 12
0	0	1	System clock divided by 4
0	1	0	Timer 0 overflow
0	1	1	High-to-low transitions on ECI (max rate = system clock divided by 4)
1	0	0	System clock
1	0	1	External clock divided by 8*
1	1	0	Reserved
1	1	1	Reserved

\***Note:** External oscillator source divided by 8 is synchronized with the system clock.

- Bit0:** ECF: PCA Counter/Timer Overflow Interrupt Enable.  
This bit sets the masking of the PCA Counter/Timer Overflow (CF) interrupt.  
0: Disable the CF interrupt.  
1: Enable a PCA Counter/Timer Overflow interrupt request when CF (PCA0CN.7) is set.

**Note:** When the WDTE bit is set to '1', the PCA0MD register cannot be modified. To change the contents of the PCA0MD register, the Watchdog Timer must first be disabled.

## SFR Definition 19.3. PCA0CPMn: PCA Capture/Compare Mode

R/W	R/W	R/W	R/W	R/W	R/W	R/W	R/W	Reset Value
PWM16n	ECOMn	CAPPn	CAPNn	MATn	TOGn	PWMn	ECCFn	00000000
Bit7	Bit6	Bit5	Bit4	Bit3	Bit2	Bit1	Bit0	

SFR Address: PCA0CPM0: 0xDA, PCA0CPM1: 0xDB, PCA0CPM2: 0xDC

Bit7: PWM16n: 16-bit Pulse Width Modulation Enable.  
This bit selects 16-bit mode when Pulse Width Modulation mode is enabled (PWMn = 1).  
0: 8-bit PWM selected.  
1: 16-bit PWM selected.

Bit6: ECOMn: Comparator Function Enable.  
This bit enables/disables the comparator function for PCA module n.  
0: Disabled.  
1: Enabled.

Bit5: CAPPn: Capture Positive Function Enable.  
This bit enables/disables the positive edge capture for PCA module n.  
0: Disabled.  
1: Enabled.

Bit4: CAPNn: Capture Negative Function Enable.  
This bit enables/disables the negative edge capture for PCA module n.  
0: Disabled.  
1: Enabled.

Bit3: MATn: Match Function Enable.  
This bit enables/disables the match function for PCA module n. When enabled, matches of the PCA counter with a module's capture/compare register cause the CCFn bit in PCA0MD register to be set to logic 1.  
0: Disabled.  
1: Enabled.

Bit2: TOGn: Toggle Function Enable.  
This bit enables/disables the toggle function for PCA module n. When enabled, matches of the PCA counter with a module's capture/compare register cause the logic level on the CEXn pin to toggle. If the PWMn bit is also set to logic 1, the module operates in Frequency Output Mode.  
0: Disabled.  
1: Enabled.

Bit1: PWMn: Pulse Width Modulation Mode Enable.  
This bit enables/disables the PWM function for PCA module n. When enabled, a pulse width modulated signal is output on the CEXn pin. 8-bit PWM is used if PWM16n is cleared; 16-bit mode is used if PWM16n is set to logic 1. If the TOGn bit is also set, the module operates in Frequency Output Mode.  
0: Disabled.  
1: Enabled.

Bit0: ECCFn: Capture/Compare Flag Interrupt Enable.  
This bit sets the masking of the Capture/Compare Flag (CCFn) interrupt.  
0: Disable CCFn interrupts.  
1: Enable a Capture/Compare Flag interrupt request when CCFn is set.

# C8051F330/1/2/3/4/5

## SFR Definition 19.4. PCA0L: PCA Counter/Timer Low Byte

R/W	R/W	R/W	R/W	R/W	R/W	R/W	R/W	Reset Value
								00000000
Bit7	Bit6	Bit5	Bit4	Bit3	Bit2	Bit1	Bit0	

SFR Address: 0xF9

Bits 7–0: PCA0L: PCA Counter/Timer Low Byte.  
The PCA0L register holds the low byte (LSB) of the 16-bit PCA Counter/Timer.

## SFR Definition 19.5. PCA0H: PCA Counter/Timer High Byte

R/W	R/W	R/W	R/W	R/W	R/W	R/W	R/W	Reset Value
								00000000
Bit7	Bit6	Bit5	Bit4	Bit3	Bit2	Bit1	Bit0	

SFR Address: 0xFA

Bits 7–0: PCA0H: PCA Counter/Timer High Byte.  
The PCA0H register holds the high byte (MSB) of the 16-bit PCA Counter/Timer.

## SFR Definition 19.6. PCA0CPLn: PCA Capture Module Low Byte

R/W	R/W	R/W	R/W	R/W	R/W	R/W	R/W	Reset Value
								00000000
Bit7	Bit6	Bit5	Bit4	Bit3	Bit2	Bit1	Bit0	

SFR Address: PCA0CPL0: 0xFB, PCA0CPL1: 0xE9, PCA0CPL2: 0xEB

Bits7–0: PCA0CPLn: PCA Capture Module Low Byte.  
The PCA0CPLn register holds the low byte (LSB) of the 16-bit capture module n.

## SFR Definition 19.7. PCA0CPHn: PCA Capture Module High Byte

R/W	R/W	R/W	R/W	R/W	R/W	R/W	R/W	Reset Value
								00000000
Bit7	Bit6	Bit5	Bit4	Bit3	Bit2	Bit1	Bit0	

SFR Address: PCA0CPH0: 0xFC, PCA0CPH1: 0xEA, PCA0CPH2: 0xEC

Bits7–0: PCA0CPHn: PCA Capture Module High Byte.  
The PCA0CPHn register holds the high byte (MSB) of the 16-bit capture module n.





# C8051F330/1/2/3/4/5

## C2 Register Definition 20.3. REVID: C2 Revision ID

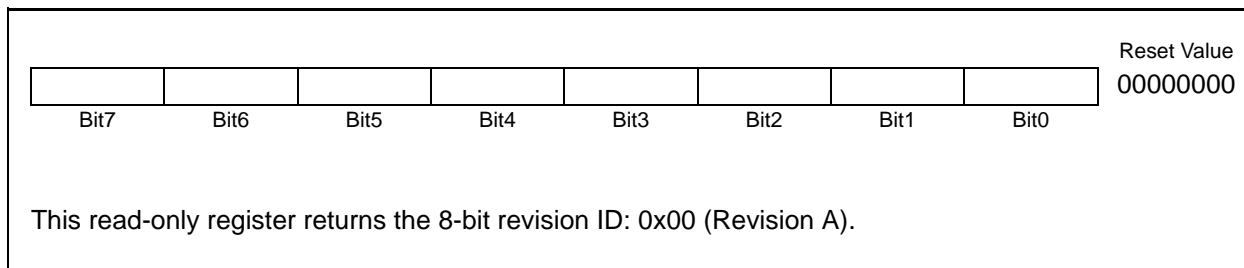

## C2 Register Definition 20.4. FPCTL: C2 Flash Programming Control

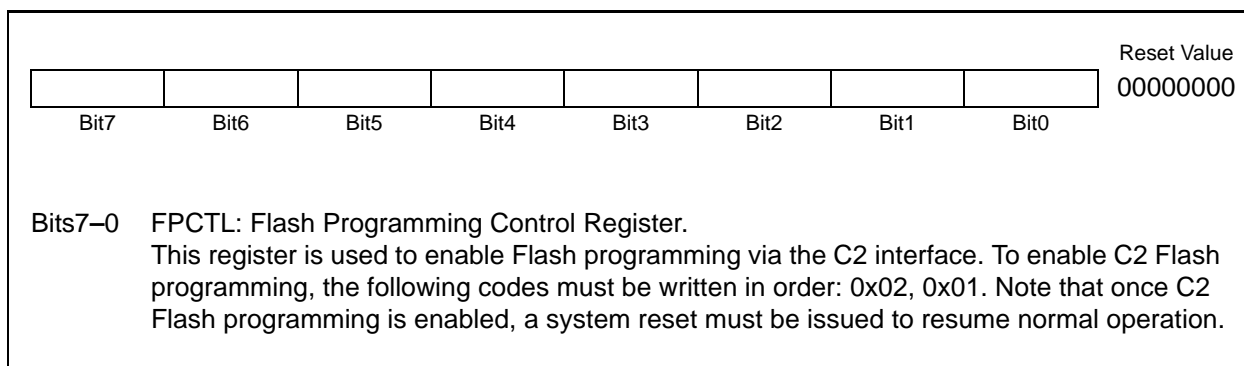

## C2 Register Definition 20.5. FPDAT: C2 Flash Programming Data

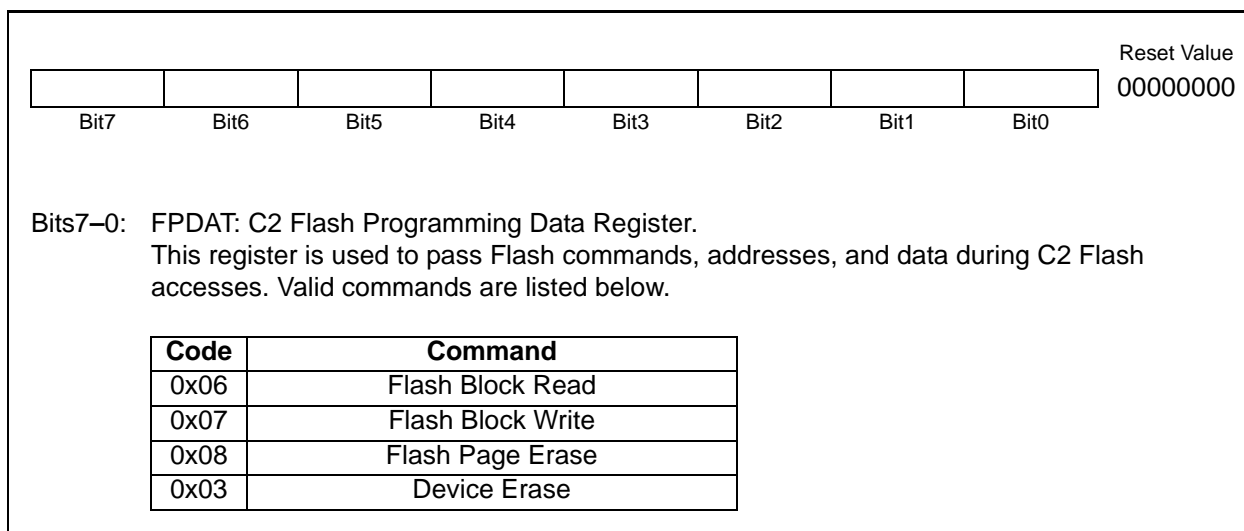

## 20.2. C2 Pin Sharing

The C2 protocol allows the C2 pins to be shared with user functions so that in-system debugging and Flash programming may be performed. This is possible because C2 communication is typically performed when the device is in the halt state, where all on-chip peripherals and user software are stalled. In this halted state, the C2 interface can safely 'borrow' the C2CK ( $\overline{RST}$ ) and C2D (P2.0) pins. In most applications, external resistors are required to isolate C2 interface traffic from the user application. A typical isolation configuration is shown in Figure 20.1.

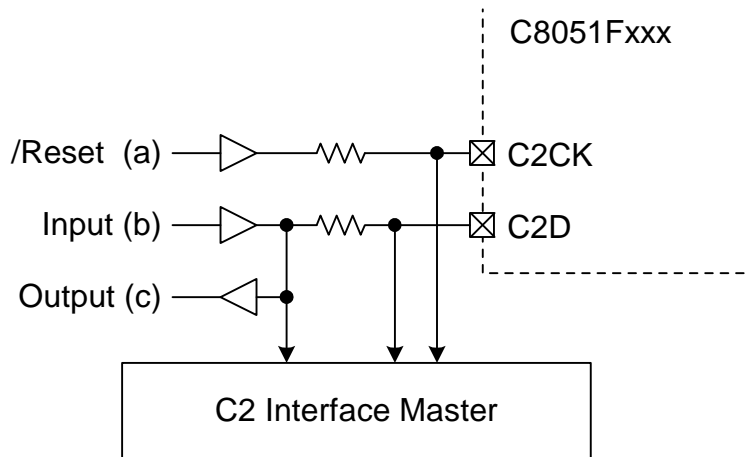

**Figure 20.1. Typical C2 Pin Sharing**

The configuration in Figure 20.1 assumes the following:

1. The user input (b) cannot change state while the target device is halted.
2. The  $\overline{RST}$  pin on the target device is used as an input only.

Additional resistors may be necessary depending on the specific application.

# C8051F330/1/2/3/4/5

---

## DOCUMENT CHANGE LIST

### Revision 1.3 to Revision 1.4

- Removed references to C8051F330D throughout the data sheet because the 'F330D device is functionally identical to the C8051F330 device (these two part numbers differ by package type only).
- Updated titles of Chapters 5, 6, and 7 to show supported devices.
- Updated Table 1.1, "Product Selection Guide," on page 18.
  - Added ordering part number information for lead-free parts.
- Added Table 3.2, "Index to Electrical Characteristics Tables," on page 34
- Added Table 11.2, "Flash Security Summary," on page 106 for clarity, replacing the Flash security summaries text.

### Revision 1.4 to Revision 1.5

- Updated Table 3.1 - Added supply current data from characterization.
- Updated Table 5.1 - Added MIN/MAX numbers for ADC Offset and Full Scale Error.
- Fixed SFR Definition 8.2 - Typo in bit descriptions - "2-0" changed to "3-0".
- Fixed SFR Definition 9.4 - Text at bottom of figure was cut off.
- Added [Section "11.4. Flash Write and Erase Guidelines" on page 107](#).
- Fixed [Section "12. External RAM" on page 111](#), paragraph 2 - Typo in description - "upper 6-bits" changed to "upper 7 bits".
- Fixed text in [Section "19.3.2. Watchdog Timer Usage" on page 203](#) to read "256 PCA clock cycles, or 3072 system clock cycles".
- Changed Table 19.4, Note 2 to refer to SYSCLK reset frequency = Internal Oscillator / 8.
- Fixed Equation 19.6, "Watchdog Timer Offset in PCA Clocks," - Typo in equation - "PCA0CPL4" changed to "PCA0CPL2".

### Revision 1.5 to Revision 1.6

- Updated package drawings.

### Revision 1.6 to Revision 1.7

- Removed PDIP package information.

---

**NOTES:**



## Simplicity Studio

One-click access to MCU and wireless tools, documentation, software, source code libraries & more. Available for Windows, Mac and Linux!



**IoT Portfolio**  
[www.silabs.com/IoT](http://www.silabs.com/IoT)



**SW/HW**  
[www.silabs.com/simplicity](http://www.silabs.com/simplicity)



**Quality**  
[www.silabs.com/quality](http://www.silabs.com/quality)



**Support and Community**  
[community.silabs.com](http://community.silabs.com)

### Disclaimer

Silicon Laboratories intends to provide customers with the latest, accurate, and in-depth documentation of all peripherals and modules available for system and software implementers using or intending to use the Silicon Laboratories products. Characterization data, available modules and peripherals, memory sizes and memory addresses refer to each specific device, and "Typical" parameters provided can and do vary in different applications. Application examples described herein are for illustrative purposes only. Silicon Laboratories reserves the right to make changes without further notice and limitation to product information, specifications, and descriptions herein, and does not give warranties as to the accuracy or completeness of the included information. Silicon Laboratories shall have no liability for the consequences of use of the information supplied herein. This document does not imply or express copyright licenses granted hereunder to design or fabricate any integrated circuits. The products must not be used within any Life Support System without the specific written consent of Silicon Laboratories. A "Life Support System" is any product or system intended to support or sustain life and/or health, which, if it fails, can be reasonably expected to result in significant personal injury or death. Silicon Laboratories products are generally not intended for military applications. Silicon Laboratories products shall under no circumstances be used in weapons of mass destruction including (but not limited to) nuclear, biological or chemical weapons, or missiles capable of delivering such weapons.

### Trademark Information

Silicon Laboratories Inc., Silicon Laboratories, Silicon Labs, SiLabs and the Silicon Labs logo, CMEMS®, EFM, EFM32, EFR, Energy Micro, Energy Micro logo and combinations thereof, "the world's most energy friendly microcontrollers", Ember®, EZLink®, EZMac®, EZRadio®, EZRadioPRO®, DSPLL®, ISOModem®, Precision32®, ProSLIC®, SiPHY®, USBXpress® and others are trademarks or registered trademarks of Silicon Laboratories Inc. ARM, CORTEX, Cortex-M3 and THUMB are trademarks or registered trademarks of ARM Holdings. Keil is a registered trademark of ARM Limited. All other products or brand names mentioned herein are trademarks of their respective holders.



**SILICON LABS**

Silicon Laboratories Inc.  
 400 West Cesar Chavez  
 Austin, TX 78701  
 USA

<http://www.silabs.com>

## X-ON Electronics

Largest Supplier of Electrical and Electronic Components

*Click to view similar products for [8-bit Microcontrollers - MCU category](#):*

*Click to view products by [Silicon Labs manufacturer](#):*

Other Similar products are found below :

[CY8C20524-12PVXIT](#) [MB95F012KPFT-G-SNE2](#) [MB95F013KPMC-G-SNE2](#) [MB95F263KPF-G-SNE2](#) [MB95F264KPFT-G-SNE2](#)  
[MB95F398KPMC-G-SNE2](#) [MB95F478KPMC2-G-SNE2](#) [MB95F564KPF-G-SNE2](#) [MB95F636KWQN-G-SNE1](#) [MB95F696KPMC-G-SNE2](#)  
[MB95F698KPMC2-G-SNE2](#) [MB95F698KPMC-G-SNE2](#) [MB95F818KPMC1-G-SNE2](#) [901015X](#) [CY8C3MFIDOCK-125](#) [403708R](#)  
[MB95F354EPF-G-SNE2](#) [MB95F564KWQN-G-SNE1](#) [MB95F636KP-G-SH-SNE2](#) [MB95F694KPMC-G-SNE2](#) [MB95F778JPMC1-G-SNE2](#)  
[MB95F818KPMC-G-SNE2](#) [LC87F0G08AUJA-AH](#) [CP8361BT](#) [CG8421AF](#) [MB95F202KPF-G-SNE2](#) [DF36014FPV](#) [5962-8768407MUA](#)  
[MB95F318EPMC-G-SNE2](#) [MB94F601APMC1-GSE1](#) [MB95F656EPF-G-SNE2](#) [LC78615E-01US-H](#) [LC87F5WC8AVU-QIP-H](#)  
[MB95F108AJSPMC-G-JNE1](#) [73S1210F-68M/F/PJ](#) [MB89F538-101PMC-GE1](#) [LC87F7DC8AVU-QIP-H](#) [MB95F876KPMC-G-SNE2](#)  
[MB88386PMC-GS-BNDE1](#) [LC87FBK08AU-SSOP-H](#) [LC87F2C64AU-QFP-H](#) [MB95F636KNWQN-G-118-SNE1](#) [MB95F136NBSTPFV-GS-](#)  
[N2E1](#) [LC87F5NC8AVU-QIP-E](#) [CY8C20324-12LQXIT](#) [LC87F76C8AU-TQFP-E](#) [CG8581AA](#) [LC87F2G08AU-SSOP-E](#) [CP8085AT](#)  
[ATTINY3224-SSU](#)