

### Features

- 32-bit ARM® Cortex -M3 processor
- 2.4 GHz IEEE 802.15.4-2003 transceiver & lower MAC
- 128 kB flash, with optional read protection
- 12 kB RAM memory
- AES128 encryption accelerator
- Flexible ADC, UART/SPI/TWI serial communications, and general purpose timers
- 24 highly configurable GPIOs with Schmitt trigger inputs

### Industry-leading ARM® Cortex -M3 processor

- Leading 32-bit processing performance
- Highly efficient Thumb-2 instruction set
- Operation at 6, 12, or 24 MHz
- Flexible Nested Vectored Interrupt Controller

### Low power consumption, advanced management

- RX Current (w/ CPU): 26 mA
- TX Current (w/ CPU, +3 dBm TX): 31 mA
- Low deep sleep current, with retained RAM and GPIO: 400 nA without/800 nA with sleep timer
- Low-frequency internal RC oscillator for low-power sleep timing
- High-frequency internal RC oscillator for fast (110 μs) processor start-up from sleep

### Exceptional RF Performance

- Normal mode link budget up to 103 dB; configurable up to 110 dB
- -100 dBm normal RX sensitivity; configurable to -102 dBm (1% PER, 20 byte packet)
- +3 dB normal mode output power; configurable up to +8 dBm
- Robust Wi-Fi and Bluetooth coexistence

### Innovative network and processor debug

- Packet Trace Port for non-intrusive packet trace with Ember development tools
- Serial Wire/JTAG interface
- Standard ARM debug capabilities: Flash Patch & Breakpoint; Data Watchpoint & Trace; Instrumentation Trace Macrocell

### Application Flexibility

- Single voltage operation: 2.1–3.6 V with internal 1.8 and 1.25 V regulators
- Optional 32.768 kHz crystal for higher timer accuracy
- Low external component count with single 24 MHz crystal
- Support for external power amplifier
- Small 7x7 mm 48-pin QFN package

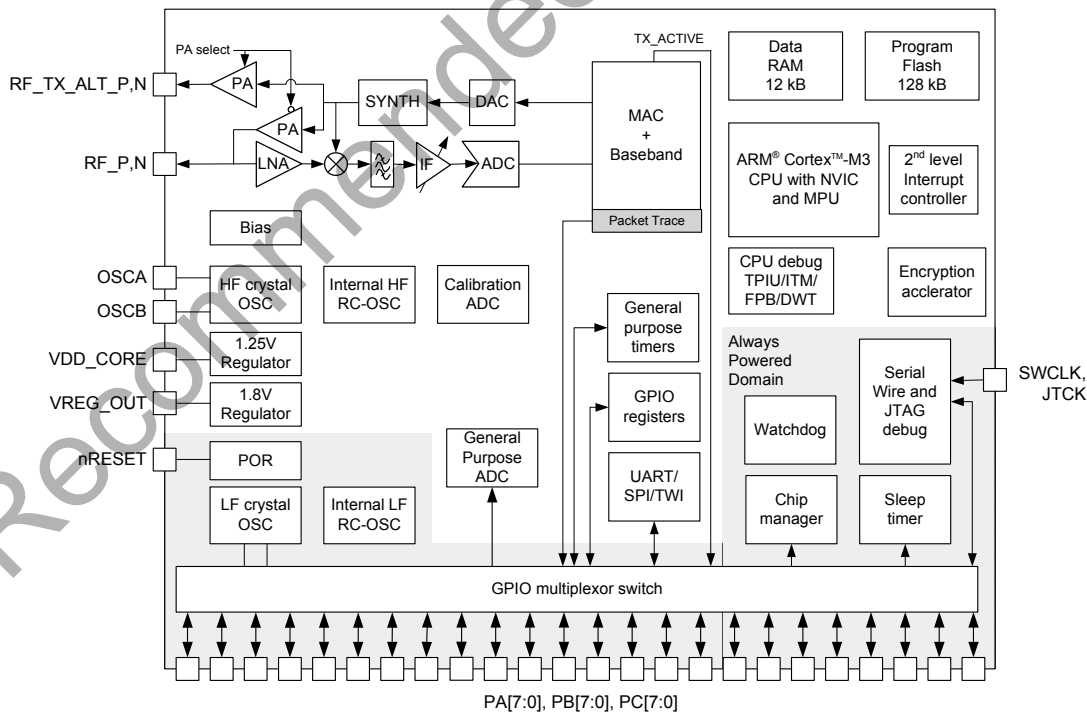

## Table of Contents

<b>1. Typical Application</b> .....	<b>4</b>
<b>2. Electrical Specifications</b> .....	<b>7</b>
2.1. Absolute Maximum Ratings.....	7
2.2. Recommended Operating Conditions .....	7
2.3. Environmental Characteristics.....	8
2.4. DC Electrical Characteristics .....	8
2.5. Digital I/O Specifications .....	13
2.6. Non-RF System Electrical Characteristics .....	14
2.7. RF Electrical Characteristics .....	15
<b>3. Functional Description</b> .....	<b>21</b>
<b>4. Radio Module</b> .....	<b>24</b>
4.1. Receive (RX) Path.....	24
4.2. Transmit (TX) Path .....	24
4.3. Calibration .....	24
4.4. Integrated MAC Module .....	25
4.5. Packet Trace Interface (PTI) .....	25
4.6. Random Number Generator.....	25
<b>5. ARM® Cortex™-M3 and Memory Modules</b> .....	<b>26</b>
5.1. ARM® Cortex™-M3 Microprocessor.....	26
5.2. Embedded Memory .....	26
5.3. Memory Protection Unit.....	32
<b>6. System Modules</b> .....	<b>33</b>
6.1. Power Domains .....	34
6.2. Resets .....	35
6.3. Clocks.....	38
6.4. System Timers .....	43
6.5. Power Management .....	44
6.6. Security Accelerator .....	47
<b>7. GPIO (General Purpose Input/Output)</b> .....	<b>48</b>
7.1. GPIO Ports .....	49
7.2. Configuration.....	49
7.3. Forced Functions.....	50
7.4. Reset.....	50
7.5. Boot Configuration.....	51
7.6. GPIO Modes.....	51
7.7. Wake Monitoring .....	52
7.8. External Interrupts .....	53
7.9. Debug Control and Status .....	54
7.10. GPIO Signal Assignment Summary.....	55
7.11. Registers.....	56
<b>8. Serial Controllers</b> .....	<b>68</b>
8.1. Overview .....	68
8.2. Configuration .....	69
8.3. SPI—Slave Mode .....	74

---

8.4. UART—Universal Asynchronous Receiver/Transmitter .....	78
8.5. DMA Channels .....	86
<b>9. Interrupt System .....</b>	<b>100</b>
9.1. Nested Vectored Interrupt Controller (NVIC).....	100
9.2. Event Manager .....	102
9.3. Non-Maskable Interrupt (NMI).....	104
9.4. Faults.....	105
9.5. Registers .....	106
<b>10. Trace Port Interface Unit (TPIU).....</b>	<b>113</b>
<b>11. Instrumentation Trace Macrocell (ITM) .....</b>	<b>114</b>
<b>12. Data Watchpoint and Trace (DWT) .....</b>	<b>115</b>
<b>13. Flash Patch and Breakpoint (FPB) .....</b>	<b>116</b>
<b>14. Integrated Voltage Regulator.....</b>	<b>117</b>
<b>15. Serial Wire and JTAG (SWJ) Interface .....</b>	<b>119</b>
<b>16. Ordering Information .....</b>	<b>120</b>
<b>17. Pin Definitions.....</b>	<b>121</b>
17.1. Pin Definitions .....	121
<b>18. Package .....</b>	<b>128</b>
<b>19. Top Marking.....</b>	<b>131</b>
<b>Appendix A—Register Address Table.....</b>	<b>132</b>
<b>Appendix B—Abbreviations and Acronyms.....</b>	<b>137</b>
<b>Appendix C—References .....</b>	<b>141</b>
<b>Document Change List .....</b>	<b>142</b>
<b>Contact Information .....</b>	<b>143</b>

## 1. Typical Application

Figure 1.1 illustrates the typical application circuit, and Table 1.1 contains an example bill of materials (BOM) for the off-chip components required by the EM341.

**Note:** The circuit shown in Figure 1.1 is for example purposes only, and the BOM is for budgetary quotes only. For a complete reference design, please download one of the latest Ember Hardware Reference Designs from the Silicon Labs website ([www.silabs.com/zigbee-support](http://www.silabs.com/zigbee-support)).

The Balun provides an impedance transformation from the antenna to the EM341 for both TX and RX modes.

L1 tunes the impedance presented to the RF port for maximum transmit power and receive sensitivity.

The harmonic filter (L2, L3, C5, C6 and C9) provides additional suppression of the second harmonic, which increases the margin over the FCC limit.

The 24 MHz crystal Y1 with loading capacitors is required and provides the high-frequency crystal oscillator source for the EM341's main system clock. The 32.768 kHz crystal with loading capacitors generates a highly accurate low-frequency crystal oscillator for use with peripherals, but it is not mandatory as the low-frequency internal RC oscillator can be used.

Loading capacitance and ESR (C1 and R3) provides stability for the internal 1.8 V regulator.

Loading capacitance C2 provides stability for the internal 1.25 V regulator, no ESR is required because it is contained within the chip.

Resistor R1 reduces the operating voltage of the flash memory, this reduces current consumption and improves sensitivity by 1 dB when compared to not using it.

Various decoupling capacitors are required, these should be placed as close to their corresponding pins as possible. For values and locations see one of the latest reference designs.

An antenna matched to 50  $\Omega$  is required.

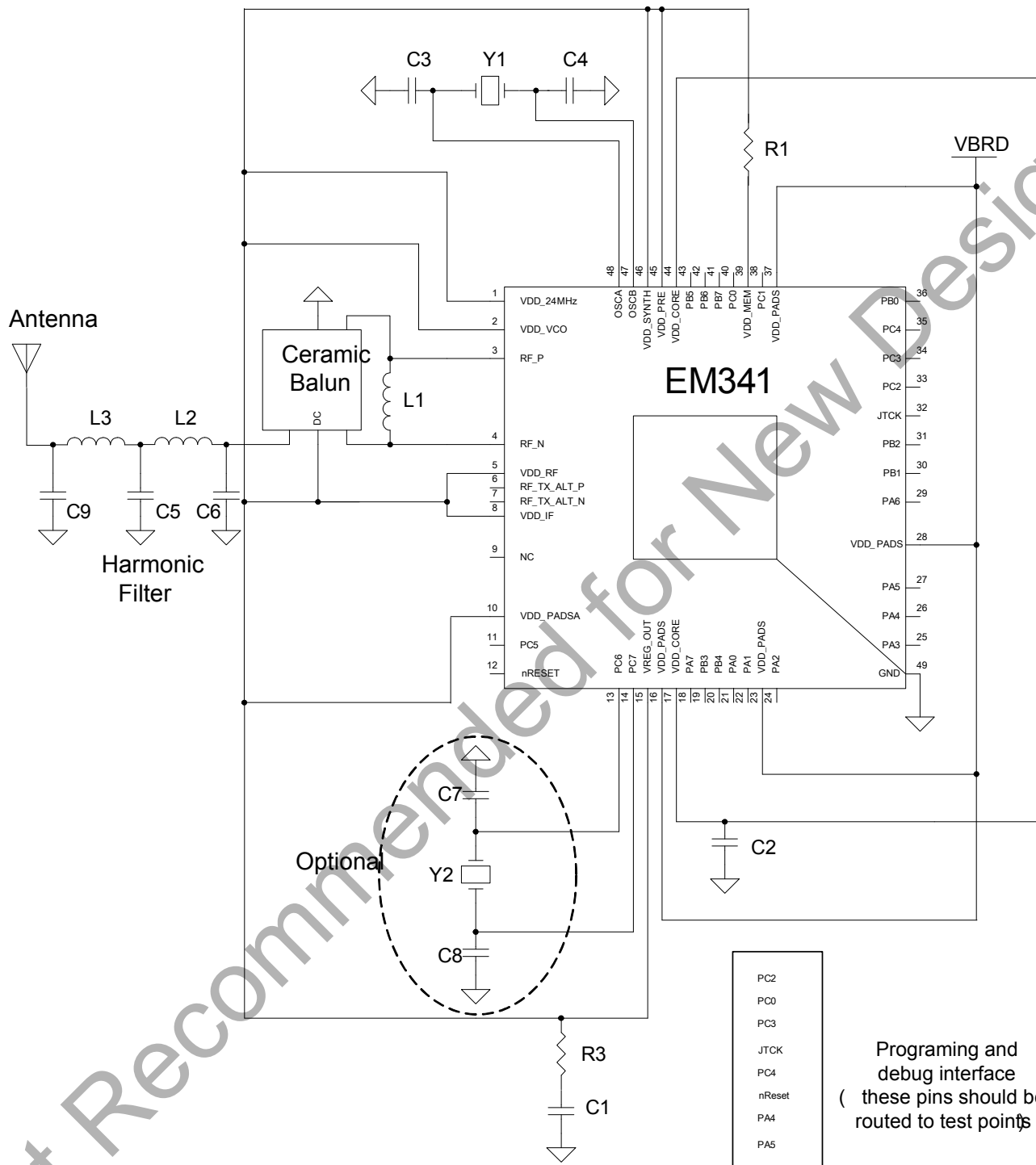

Figure 1.1. Typical Application Circuit

# EM341

Table 1.1 contains a typical Bill of Materials for the application circuit shown in Figure 1.1. The information within this table should be used for a rough cost analysis. For a more detailed BOM, please refer to one of Ember EM357-based reference designs at the Silicon Labs website ([www.silabs.com/zigbee-support](http://www.silabs.com/zigbee-support)).

**Table 1.1. Bill of Materials for Typical Application Circuit**

Item	Qty	Reference	Description	Manufacturer
1	1	C2	CAPACITOR, 1 $\mu$ F, 6.3 V, X5R, 10%, 0402	<not specified>
2	1	C1	CAPACITOR, 2.2 $\mu$ F, 10 V, X5R, 10%, 0603	<not specified>
3	1	C7	CAPACITOR, 22 pF, $\pm$ 5%, 50 V, NPO, 0402	<not specified>
4	2	C3,C4	CAPACITOR, 18 pF, $\pm$ 5%, 50 V, NPO, 0402	<not specified>
5	1	C8	CAPACITOR, 33 pF, $\pm$ 5%, 50 V, NPO, 0402	<not specified>
6	2	C5, C9	CAPACITOR, 1 pF, $\pm$ 0.25 pF, 50 V, 0402, NPO	<not specified>
7	1	C6	CAPACITOR, 1.8 pF, $\pm$ 0.25 pF, 50 V, 0402, NPO	
8	1	L1	INDUCTOR, 5.1 nH, $\pm$ 0.3 nH, 0402 MULTILAYER	Murata LQG15HS5N1
9	2	L2, L3	INDUCTOR, 2.7 nH, $\pm$ 0.3 nH, 0402, MULTILAYER	Murata LQG15HS2N7
10	1	R1	RESISTOR, 10 $\Omega$ , 5%, 0402	<not specified>
11	1	R3	RESISTOR, 1 $\Omega$ , 5%, 0402	<not specified>
12	1	U1	EM341 SINGLE-CHIP RF4CE SOLUTION	Ember EM341
13	1	Y1	CRYSTAL, 24.000 MHz, $\pm$ 25 ppm STABILITY OVER $-40$ to $+85$ $^{\circ}$ C, 18 pF	ILSI, Abracon, KDS, Epson
14	1	Y2 (Optional)	CRYSTAL, 32.768 kHz, $\pm$ 20 ppm INITIAL TOLERANCE AT $+25^{\circ}$ C, 12.5 pF	Abracon, KDS, Epson
15	1	BLN1	BALUN, CERAMIC 50/100 $\Omega$	Wurth 748421245 Johanson 2450BL15B100E Murata LDB212G4010C
16	1	ANT1	ANTENNA	Johanson 2450AT18B100E

## 2. Electrical Specifications

### 2.1. Absolute Maximum Ratings

Table 2.1 lists the absolute maximum ratings for the EM341.

**Table 2.1. Absolute Maximum Ratings**

Parameter	Test Condition	Min	Max	Unit
Regulator input voltage (VDD_PADS)		-0.3	+3.6	V
Analog, Memory and Core voltage (VDD_24MHZ, VDD_VCO, VDD_RF, VDD_IF, VDD_PADSA, VDD_MEM, VDD_PRE, VDD_SYNTN, VDD_CORE)		-0.3	+2.0	V
Voltage on RF_P,N; RF_TX_ALT_P,N		-0.3	+3.6	V
RF Input Power (for max level for correct packet reception see Table 2.7)	RX signal into a lossless balun		+15	dBm
Voltage on any GPIO (PA[7:0], PB[7:0], PC[7:0]), SWCLK, nRESET, VREG_OUT		-0.3	VDD_PADS +0.3	V
Voltage on any GPIO pin (PA4, PA5, PB5, PB6, PB7, PC1), when used as an input to the general purpose ADC		-0.3	2.0	V
Voltage on OSCA, OSCB, NC		-0.3	VDD_PADSA +0.3	V
Storage temperature		-40	+140	°C

**Note:** Exposure to absolute-maximum-rated conditions for extended periods may affect device reliability.

### 2.2. Recommended Operating Conditions

Table 2.2 lists the rated operating conditions of the EM341.

**Table 2.2. Operating Conditions**

Parameter	Test Condition	Min	Typ	Max	Unit
Regulator input voltage (VDD_PADS)		2.1	—	3.6	V
Analog and memory input voltage (VDD_24MHZ, VDD_VCO, VDD_RF, VDD_IF, VDD_PADSA, VDD_MEM, VDD_PRE, VDD_SYNTN)		1.7	1.8	1.9	V
Core input voltage when supplied from internal regulator (VDD_CORE)		1.18	1.25	1.32	V
Core input voltage when supplied externally (VDD_CORE)		1.18	—	1.9	V
Operating temperature range, T <sub>A</sub>		-40	—	+85	°C

**Note:** Exposure to absolute-maximum-rated conditions for extended periods may affect device reliability.

# EM341

## 2.3. Environmental Characteristics

Table 2.3 lists the rated environmental characteristics of the EM341.

**Table 2.3. Environmental Characteristics**

Parameter	Symbol	Test Condition	Min	Typ	Max	Unit
ESD (human body model)		On any pin	—	—	±2	kV
ESD (charged device model)		Non-RF pins	—	—	±400	V
ESD (charged device model)		RF pins	—	—	±225	V
Package Thermal Resistance*	$\theta_{JA}$			27.1		°C/W

\*Note: Thermal resistance assumes multi-layer PCB with exposed pad soldered to a PCB board.

## 2.4. DC Electrical Characteristics

Table 2.4 lists the dc electrical characteristics of the EM341.

**Table 2.4. DC Characteristics**

Measured on Silicon Labs' EM357 reference design with  $T_A = 25\text{ °C}$  and  $V_{DD} = 3\text{ V}$ , unless otherwise noted.

Parameter	Test Condition	Min	Typ	Max	Unit
Regulator input voltage (VDD_PADS)		2.1	—	3.6	V
Power supply range (VDD_MEM)	Regulator output or external input	1.7	1.8	1.9	V
Power supply range (VDD_CORE)	Regulator output	1.18	1.25	1.32	V
<b>Deep Sleep Current</b>					
Quiescent current, internal RC oscillator disabled	−40 °C, VDD_PADS=3.6 V	—	0.4	—	μA
	+25 °C, VDD_PADS=3.6 V	—	0.4	—	μA
	+85 °C, VDD_PADS=3.6 V	—	0.7	—	μA
Quiescent current, including internal RC oscillator	−40 °C, VDD_PADS=3.6 V	—	0.7	—	μA
	+25 °C, VDD_PADS=3.6 V	—	0.7	—	μA
	+85 °C, VDD_PADS=3.6 V	—	1.1	—	μA
Quiescent current, including 32.768 kHz oscillator	−40 °C, VDD_PADS=3.6 V	—	0.8	—	μA
	+25 °C, VDD_PADS=3.6 V	—	1.0	—	μA
	+85 °C, VDD_PADS=3.6 V	—	1.5	—	μA
Quiescent current, including internal RC oscillator and 32.768 kHz oscillator	−40 °C, VDD_PADS=3.6 V	—	1.1	—	μA
	+25 °C, VDD_PADS=3.6 V	—	1.3	—	μA
	+85 °C, VDD_PADS=3.6 V	—	1.8	—	μA
Simulated deep sleep (debug mode) current	With no debugger activity	—	300	—	μA



**Table 2.4. DC Characteristics (Continued)**Measured on Silicon Labs' EM357 reference design with  $T_A = 25\text{ }^\circ\text{C}$  and  $V_{DD} = 3\text{ V}$ , unless otherwise noted.

Parameter	Test Condition	Min	Typ	Max	Unit
<b>Reset Current</b>					
Quiescent current, nRESET asserted	Typ at 25 °C/3.0 V Max at 85 °C/3.6 V	—	1.2	2.0	mA
<b>Processor and Peripheral Currents</b>					
ARM® Cortex™-M3, RAM, and flash memory	25 °C, 1.8 V memory and 1.25 V core ARM® Cortex™-M3 running at 12 MHz from crystal oscillator Radio and all peripherals off	—	6.5	—	mA
ARM® Cortex™-M3, RAM, and flash memory	25 °C, 1.8 V memory and 1.25 V core ARM® Cortex™-M3 running at 24 MHz from crystal oscillator Radio and all peripherals off	—	7.5	—	mA
ARM® Cortex™-M3, RAM, and flash memory sleep current	25 °C, 1.8 V memory and 1.25 V core ARM® Cortex™-M3 sleeping, CPU clock set to 12 MHz from the crystal oscillator Radio and all peripherals off	—	3.0	—	mA
ARM® Cortex™-M3, RAM, and flash memory sleep current	25 °C, 1.8 V memory and 1.25 V core ARM® Cortex™-M3 sleeping, CPU clock set to 6 MHz from the high frequency RC oscillator Radio and all peripherals off	—	2.0	—	mA
Serial controller current	For each controller at maximum data rate	—	0.2	—	mA
General purpose timer current	For each timer at maximum clock rate	—	0.25	—	mA
General purpose ADC current	At maximum sample rate, DMA enabled	—	1.1	—	mA
<b>RX Current</b>					
Radio receiver, MAC, and baseband	ARM® Cortex™-M3 sleeping, CPU clock set to 12 MHz	—	22.0	—	mA
Total RX current ( = $I_{\text{Radio receiver, MAC and baseband, CPU + IRAM, and Flash memory}}$ )	25 °C, VDD_PADS=3.0 V ARM® Cortex™-M3 running at 12 MHz	—	25.5	—	mA
	25 °C, VDD_PADS=3.0 V ARM® Cortex™-M3 running at 24 MHz	—	26.5	—	mA
Boost mode total RX current ( = $I_{\text{Radio receiver, MAC and baseband, CPU+ IRAM, and flash memory}}$ )	25 °C, VDD_PADS=3.0 V ARM® Cortex™-M3 running at 12 MHz	—	27.5	—	mA
	25 °C, VDD_PADS=3.0 V ARM® Cortex™-M3 running at 24 MHz	—	28.5	—	mA

# EM341

**Table 2.4. DC Characteristics (Continued)**

Measured on Silicon Labs' EM357 reference design with  $T_A = 25\text{ }^\circ\text{C}$  and  $V_{DD} = 3\text{ V}$ , unless otherwise noted.

Parameter	Test Condition	Min	Typ	Max	Unit
<b>TX Current</b>					
Radio transmitter, MAC, and baseband	25 °C and 1.8 V core; max. power out (+3 dBm typical) ARM® Cortex™-M3 sleeping, CPU clock set to 12 MHz	—	26.0	—	mA
Total TX current (= $I_{\text{Radio transmitter, MAC and baseband, CPU + IRAM, and flash memory}}$ )	25 °C, VDD_PADS=3.0 V; maximum power setting (+8 dBm); ARM® Cortex™-M3 running at 12 MHz	—	42.5	—	mA
	25 °C, VDD_PADS=3.0 V; +3 dBm power setting; ARM® Cortex™-M3 running at 12 MHz	—	30.0	—	mA
	25 °C, VDD_PADS=3.0 V; 0 dBm power setting; ARM® Cortex™-M3 running at 12 MHz	—	27.5	—	mA
	25 °C, VDD_PADS=3.0 V; minimum power setting; ARM® Cortex™-M3 running at 12 MHz	—	21.5	—	mA
	25 °C, VDD_PADS=3.0 V; maximum power setting (+8 dBm); ARM® Cortex™-M3 running at 24 MHz	—	43.5	—	mA
	25 °C, VDD_PADS=3.0 V; +3 dBm power setting; ARM® Cortex™-M3 running at 24 MHz	—	31.0	—	mA
	25 °C, VDD_PADS=3.0 V; 0 dBm power setting; ARM® Cortex™-M3 running at 24 MHz	—	28.5	—	mA
	25 °C, VDD_PADS=3.0 V; minimum power setting; ARM® Cortex™-M3 running at 24 MHz	—	22.5	—	mA

Figure 2.1 shows the variation of current in transmit mode (with the ARM<sup>®</sup> Cortex<sup>™</sup>-M3 running at 12 MHz).

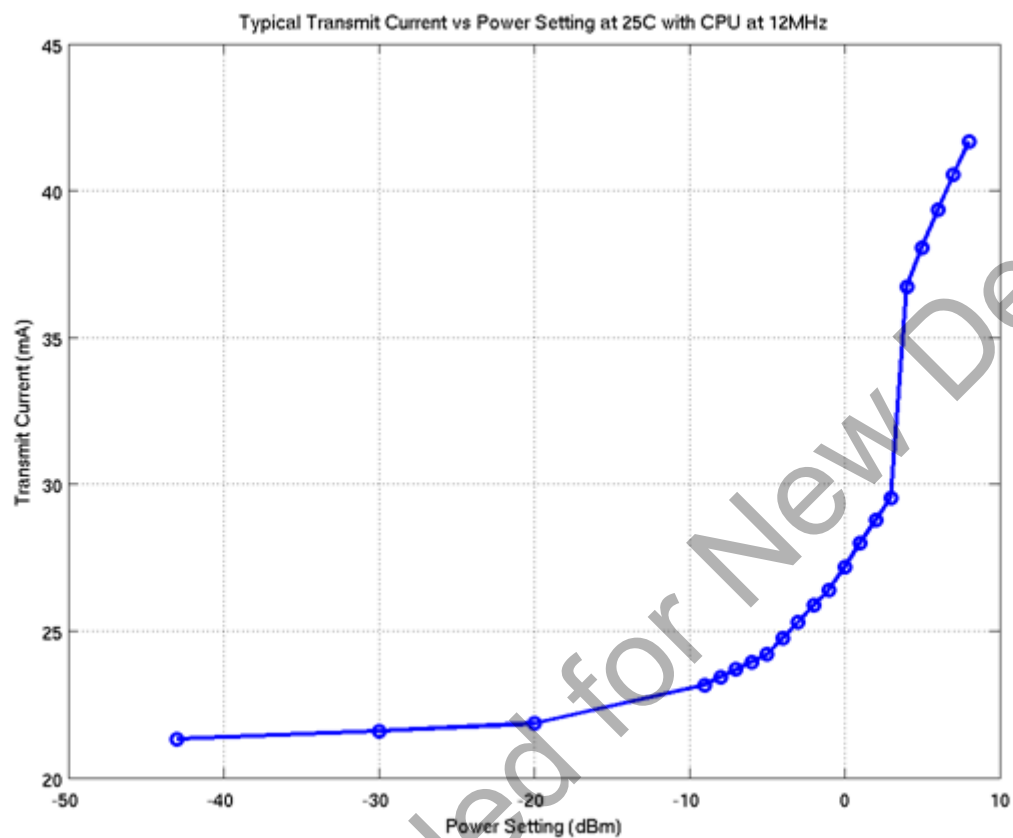

Figure 2.1. Transmit Power Consumption

Figure 2.2 shows typical output power against power setting on the Silicon Labs reference design.

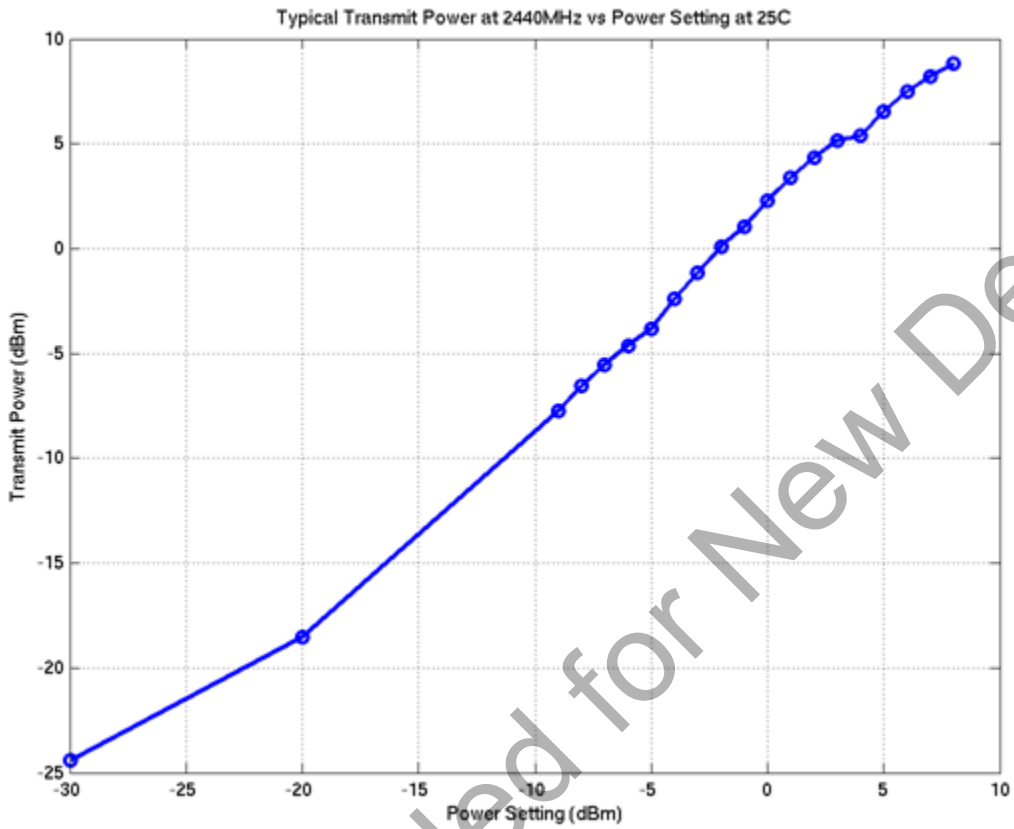

Figure 2.2. Transmit Output Power

## 2.5. Digital I/O Specifications

Table 2.5 lists the digital I/O specifications for the EM341. The digital I/O power (named VDD\_PADS) comes from three dedicated pins (pins 23, 28 and 37). The voltage applied to these pins sets the I/O voltage.

**Table 2.5. Digital I/O Specifications**

Parameter	Test Condition	Min	Typ	Max	Unit
Voltage supply (regulator input voltage)		2.1	—	3.6	V
Low Schmitt switching threshold	$V_{SWIL}$ Schmitt input threshold going from high to low	0.42 x VDD_PADS	—	0.50 x VDD_PADS	V
High Schmitt switching threshold	$V_{SWIH}$ Schmitt input threshold going from low to high	0.62 x VDD_PADS	—	0.80 x VDD_PADS	V
Input current for logic 0	$I_{IL}$	—	—	-0.5	$\mu$ A
Input current for logic 1	$I_{IH}$	—	—	+0.5	$\mu$ A
Input pull-up resistor value	$R_{IPU}$	24	29	34	k $\Omega$
Input pull-down resistor value	$R_{IPD}$	24	29	34	k $\Omega$
Output voltage for logic 0	$V_{OL}$ ( $I_{OL} = 4$ mA for standard pads, 8 mA for high current pads)	0	—	0.18 x VDD_PADS	V
Output voltage for logic 1	$V_{OH}$ ( $I_{OH} = 4$ mA for standard pads, 8 mA for high current pads)	0.82 x VDD_PADS	—	VDD_PADS	V
Output source current (standard current pad)	$I_{OHS}$	—	—	4	mA
Output sink current (standard current pad)	$I_{OLS}$	—	—	4	mA
Output source current high current pad: PA6, PA7, PB6, PB7, PC0	$I_{OHH}$	—	—	8	mA
Output sink current high current pad: PA6, PA7, PB6, PB7, PC0	$I_{OLH}$	—	—	8	mA
Total output current (for I/O Pads)	$I_{OH} + I_{OL}$	—	—	40	mA

# EM341

Table 2.6 lists the nRESET pin specifications for the EM341. The digital I/O power (named VDD\_PADS) comes from three dedicated pins (pins 23, 28 and 37). The voltage applied to these pins sets the I/O voltage.

**Table 2.6. nReset Pin Specifications**

Parameter	Test Condition	Min	Typ	Max	Unit
Low Schmitt switching threshold	$V_{SWIL}$ Schmitt input threshold going from high to low	0.42 x VDD_PADS	—	0.50 x VDD_PADS	V
High Schmitt switching threshold	$V_{SWIH}$ Schmitt input threshold going from low to high	0.62 x VDD_PADS	—	0.80 x VDD_PADS	V
Input current for logic 0	$I_{IL}$	—	—	-0.5	$\mu$ A
Input current for logic 1	$I_{IH}$	—	—	+0.5	$\mu$ A
Input pull-up resistor value	$R_{IPU}$ Pull-up value while the chip is not reset	24	29	34	k $\Omega$
Input pull-up resistor value	$R_{IPURESET}$ Pull-up value while the chip is reset	12	14.5	17	k $\Omega$

## 2.6. Non-RF System Electrical Characteristics

Table 2.7 lists the non-RF system level characteristics for the EM341.

**Table 2.7. Non-RF System Electrical Characteristics**

Measured on Silicon Labs' EM357 reference design with  $T_A = 25\text{ }^\circ\text{C}$  and  $V_{DD} = 3\text{ V}$ , unless otherwise noted.

Parameter	Test Condition	Min	Typ	Max	Unit
System wake time from deep sleep	From wakeup event to first ARM <sup>®</sup> Cortex <sup>™</sup> -M3 instruction running from 6 MHz internal RC clock Includes supply ramp time and oscillator startup time	—	110	—	$\mu$ s
Shutdown time going into deep sleep	From last ARM <sup>®</sup> Cortex <sup>™</sup> -M3 instruction to deep sleep mode	—	5	—	$\mu$ s

## 2.7. RF Electrical Characteristics

### 2.7.1. Receive

Table 2.8 lists the key parameters of the integrated IEEE 802.15.4-2003 receiver on the EM341.

Receive measurements were collected with the Silicon Labs EM357 Ceramic Balun Reference Design (Version A0) at 2440 MHz. The typical number indicates one standard deviation above the mean, measured at room temperature (25 °C). The min and max numbers were measured over process corners at room temperature.

**Table 2.8. Receive Characteristics**

Parameter	Test Condition	Min	Typ	Max	Unit
Frequency range		2400	—	2500	MHz
Sensitivity (boost mode)	1% PER, 20 byte packet defined by IEEE 802.15.4-2003;	—	-102	-96	dBm
Sensitivity	1% PER, 20 byte packet defined by IEEE 802.15.4-2003;	—	-100	-94	dBm
High-side adjacent channel rejection	IEEE 802.15.4-2003 interferer signal, wanted IEEE 802.15.4-2003 signal at -82 dBm	—	35	—	dB
Low-side adjacent channel rejection	IEEE 802.15.4-2003 interferer signal, wanted IEEE 802.15.4-2003 signal at -82 dBm	—	35	—	dB
2 <sup>nd</sup> high-side adjacent channel rejection	IEEE 802.15.4-2003 interferer signal, wanted IEEE 802.15.4-2003 signal at -82 dBm	—	46	—	dB
2 <sup>nd</sup> low-side adjacent channel rejection	IEEE 802.15.4-2003 interferer signal, wanted IEEE 802.15.4-2003 signal at -82 dBm	—	46	—	dB
High-side adjacent channel rejection	Filtered IEEE 802.15.4-2003 interferer signal, wanted IEEE 802.15.4-2003 signal at -82 dBm	—	39	—	dB
Low-side adjacent channel rejection	Filtered IEEE 802.15.4-2003 interferer signal, wanted IEEE 802.15.4-2003 signal at -82 dBm	—	47	—	dB
2 <sup>nd</sup> high-side adjacent channel rejection	Filtered IEEE 802.15.4-2003 interferer signal, wanted IEEE 802.15.4-2003 signal at -82 dBm	—	49	—	dB
2 <sup>nd</sup> low-side adjacent channel rejection	Filtered IEEE 802.15.4-2003 interferer signal, wanted IEEE 802.15.4-2003 signal at -82 dBm	—	49	—	dB
High-side adjacent channel rejection	CW interferer signal, wanted IEEE 802.15.4-2003 signal at -82 dBm	—	44	—	dB
Low-side adjacent channel rejection	CW interferer signal, wanted IEEE 802.15.4-2003 signal at -82 dBm	—	47	—	dB

# EM341

**Table 2.8. Receive Characteristics (Continued)**

Parameter	Test Condition	Min	Typ	Max	Unit
2 <sup>nd</sup> high-side adjacent channel rejection	CW interferer signal, wanted IEEE 802.15.4-2003 signal at -82 dBm	—	59	—	dB
2 <sup>nd</sup> low-side adjacent channel rejection	CW interferer signal, wanted IEEE 802.15.4-2003 signal at -82 dBm	—	59	—	dB
Channel rejection for all other channels	IEEE 802.15.4-2003 interferer signal, wanted IEEE 802.15.4-2003 signal at -82 dBm	—	40	—	dB
802.11g rejection centered at +12 MHz or -13 MHz	IEEE 802.15.4-2003 interferer signal, wanted IEEE 802.15.4-2003 signal at -82 dBm	—	36	—	dB
Maximum input signal level for correct operation		0	—	—	dBm
Co-channel rejection	IEEE 802.15.4-2003 interferer signal, wanted IEEE 802.15.4-2003 signal at -82 dBm	—	-6	—	dBc
Relative frequency error (50% greater than the 2x40 ppm required by IEEE 802.15.4-2003)		-120	—	+120	ppm
Relative timing error (50% greater than the 2x40 ppm required by IEEE 802.15.4-2003)		-120	—	+120	ppm
Linear RSSI range	As defined by IEEE 802.15.4-2003	40	—	—	dB
RSSI Range		-90	—	-40	dBm



Figure 2.3 shows the variation of receive sensitivity with temperature for boost mode and normal mode for a typical chip.

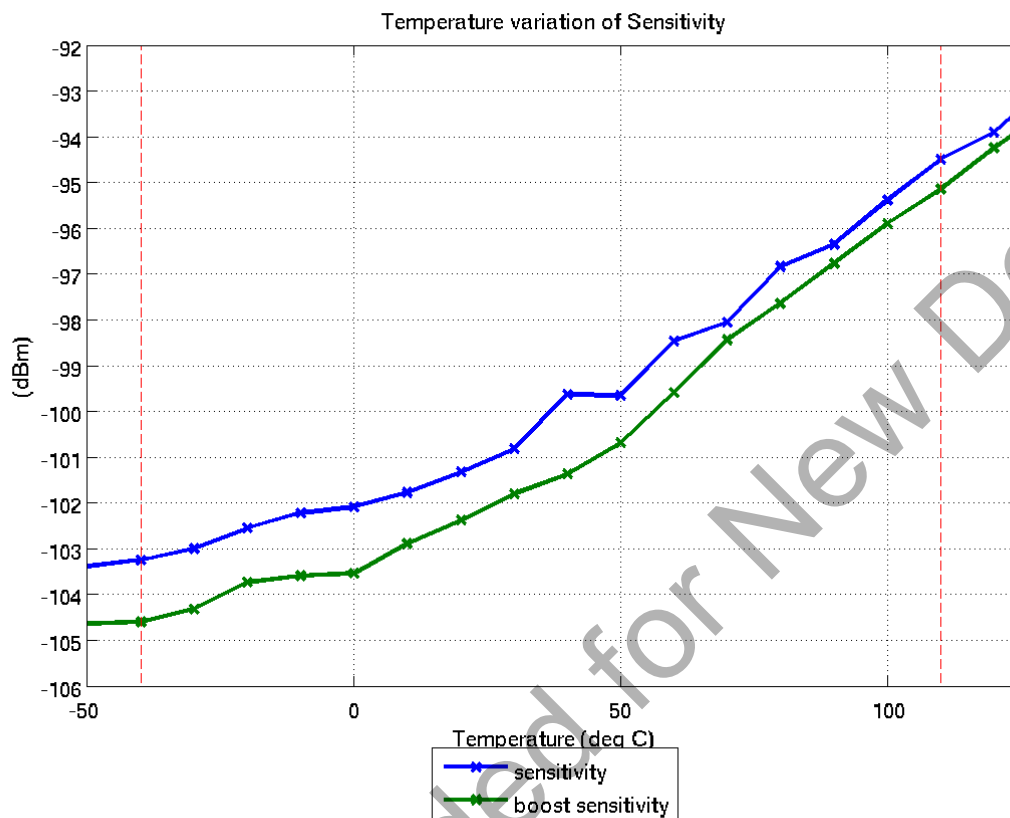

Figure 2.3. Receive Sensitivity vs. Temperature

# EM341

---

## 2.7.2. Transmit

Table 2.9 lists the key parameters of the integrated IEEE 802.15.4-2003 transmitter on the EM341.

Transmit measurements were collected with the Silicon Labs EM341 Ceramic Balun Reference Design (Version A0) at 2440 MHz. The Typical number indicates one standard deviation below the mean, measured at room temperature (25 °C). The Min and Max numbers were measured over process corners at room temperature. In terms of impedance, this reference design presents a 3n3 inductor in parallel with a 100:50  $\Omega$  balun to the RF pins.

**Table 2.9. Transmit Characteristics**

Parameter	Test Condition	Min	Typ	Max	Unit
Maximum output power (boost mode)	At highest boost mode power setting (+8)	—	8	—	dBm
Maximum output power	At highest normal mode power setting (+3)	1	5	—	dBm
Minimum output power	At lowest power setting	—	-55	—	dBm
Error vector magnitude (Offset-EVM)	As defined by IEEE 802.15.4-2003, which sets a 35% maximum	—	5	15	%
Carrier frequency error		-40	—	+40	ppm
PSD mask relative	3.5 MHz away	-20	—	—	dB
PSD mask absolute	3.5 MHz away	-30	—	—	dBm

Figure 2.4 shows the variation of transmit power with temperature for maximum boost mode power, and normal mode for a typical chip.

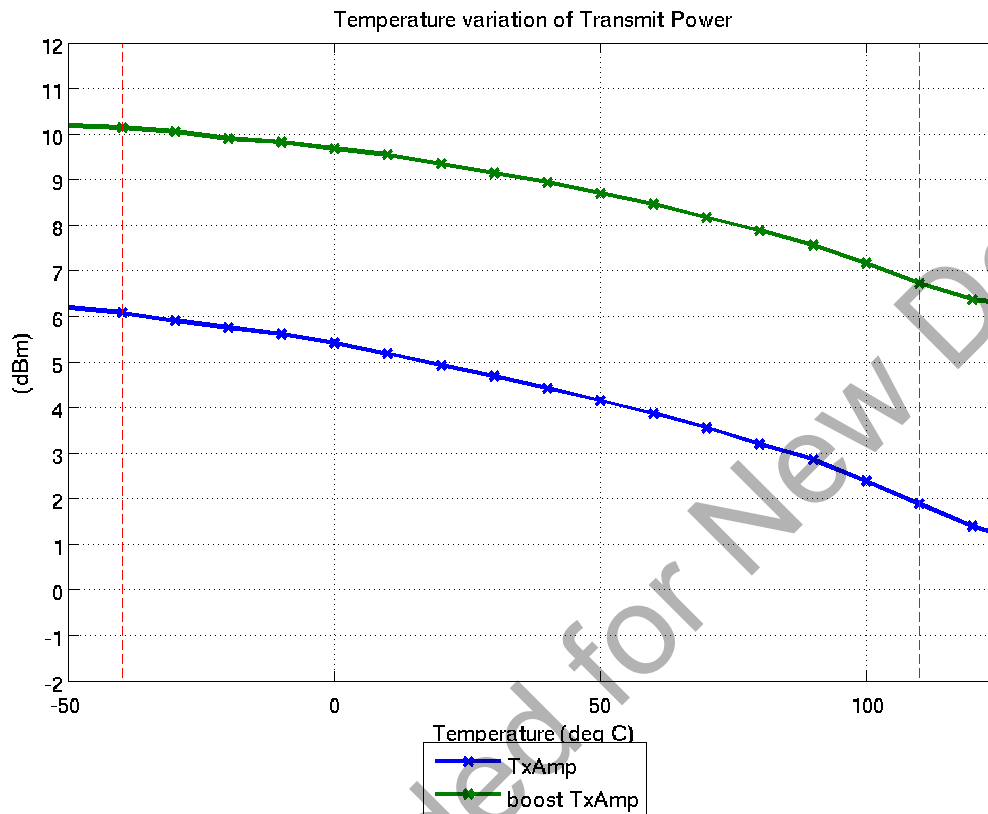

Figure 2.4. Transmit Power vs. Temperature

# EM341

## 2.7.3. Synthesizer

Table 2.10 lists the key parameters of the integrated synthesizer on the EM341.

**Table 2.10. Synthesizer Characteristics**

Measured on Silicon Labs' EM357 reference design with  $T_A = 25\text{ }^\circ\text{C}$  and  $V_{DD} = 3\text{ V}$ , unless otherwise noted.

Parameter	Test Condition	Min	Typ	Max	Unit
Frequency range		2400	—	2500	MHz
Frequency resolution		—	11.7	—	kHz
Lock time	From off	—	—	100	$\mu\text{s}$
Relock time	Channel change or RX/TX turnaround (IEEE 802.15.4-2003 defines 192 $\mu\text{s}$ turnaround time)	—	—	100	$\mu\text{s}$
Phase noise at 100 kHz offset		—	-75	—	dBc/Hz
Phase noise at 1 MHz offset		—	-100	—	dBc/Hz
Phase noise at 4 MHz offset		—	-108	—	dBc/Hz
Phase noise at 10 MHz offset		—	-114	—	dBc/Hz

### 3. Functional Description

The EM341 is a fully integrated system-on-chip that integrates a 2.4 GHz, IEEE 802.15.4-2003-compliant transceiver, 32-bit ARM<sup>®</sup> Cortex-M3 microprocessor, flash and RAM memory, and peripherals of use to designers of ZigBee-based RF4CE Remote control devices.

The transceiver uses an efficient architecture that exceeds the dynamic range requirements imposed by the IEEE 802.15.4-2003 standard by over 15 dB. The integrated receive channel filtering allows for robust co-existence with other communication standards in the 2.4 GHz spectrum, such as IEEE 802.11-2007 and Bluetooth. The integrated regulator, VCO, loop filter, and power amplifier keep the external component count low. An optional high performance radio mode (boost mode) is software-selectable to boost dynamic range.

The integrated 32-bit ARM<sup>®</sup> Cortex™-M3 microprocessor is highly optimized for high performance, low power consumption, and efficient memory utilization. Including an integrated MPU, it supports two different modes of operation—privileged mode and user mode. This architecture could allow for separation of the networking stack from the application code, and prevents unwanted modification of restricted areas of memory and registers resulting in increased stability and reliability of deployed solutions.

The EM341 has 128 kB of embedded flash memory. It has 12 kB of integrated RAM for data and program storage. The Ember software for the EM341 employs an effective wear-leveling algorithm that optimizes the lifetime of the embedded flash.

To maintain the strict timing requirements imposed by the ZigBee RF4CE and IEEE 802.15.4-2003 standards, the EM341 integrates a number of MAC functions, AES128 encryption accelerator, and automatic CRC handling into the hardware. The MAC hardware handles automatic ACK transmission and reception, automatic backoff delay, and clear channel assessment for transmission, as well as automatic filtering of received packets. The Ember Packet Trace Interface is also integrated with the MAC, allowing complete, non-intrusive capture of all packets to and from the EM341 with Ember development tools.

The EM341 offers a number of advanced power management features that enable long battery life. A high-frequency internal RC oscillator allows the processor core to begin code execution quickly upon waking. Various deep sleep modes are available with less than 1  $\mu$ A power consumption while retaining RAM contents. To support user-defined applications, on-chip peripherals include UART, SPI, TWI, ADC, and general-purpose timers, as well as up to 24 GPIOs. Additionally, an integrated voltage regulator, power-on-reset circuit, and sleep timer are available.

Finally, the EM341 utilizes standard Serial Wire and JTAG interfaces for powerful software debugging and programming of the ARM Cortex™-M3 core. The EM341 integrates the standard ARM system debug components: Flash Patch and Breakpoint (FPB), Data Watchpoint and Trace (DWT), and Instrumentation Trace Macrocell (ITM). RF4CE Remote Control is the target application for EM341.

The technical data sheet details the EM341 features available to customers using it with Ember software.

# EM341

Figure 3.1 shows a detailed block diagram of the EM341.

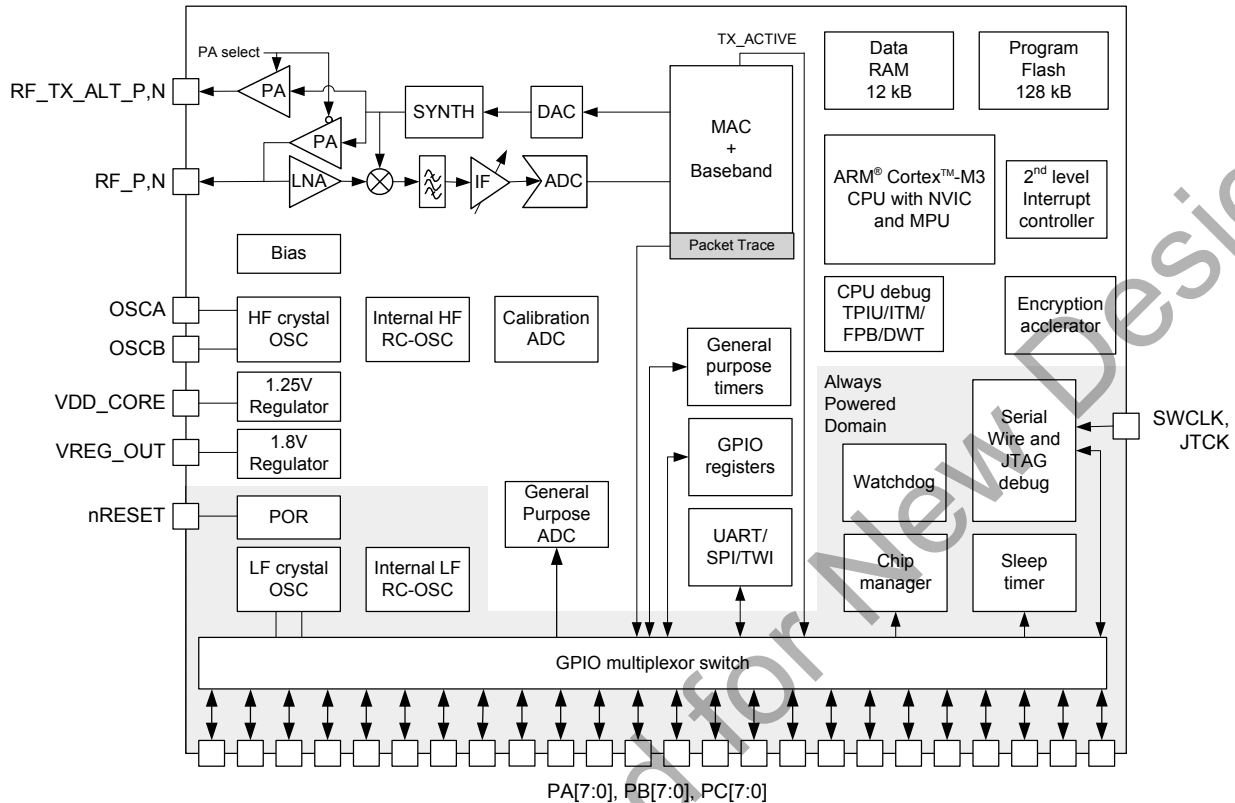

**Figure 3.1. EM341 Block Diagram**

The EM341 radio receiver is a low-IF, super-heterodyne receiver. The architecture has been chosen to optimize co-existence with other devices in the 2.4 GHz band (namely Wi-Fi and Bluetooth), and to minimize power consumption. The receiver uses differential signal paths to reduce sensitivity to noise interference. Following RF amplification, the signal is downconverted by an image-rejecting mixer, filtered, and then digitized by an ADC.

The digital section of the receiver uses a coherent demodulator to generate symbols for the hardware-based MAC. The digital receiver also contains the analog radio calibration routines, and controls the gain within the receiver path.

The radio transmitter uses an efficient architecture in which the data stream directly modulates the VCO frequency. An integrated PA provides the output power. Digital logic controls TX path and output power calibration. If the EM341 is to be used with an external PA, use the TX\_ACTIVE or nTX\_ACTIVE signal to control the timing of the external switching logic.

The integrated 4.8 GHz VCO and loop filter minimize off-chip circuitry. Only a 24 MHz crystal with its loading capacitors is required to establish the PLL local oscillator signal.

The MAC interfaces the on-chip RAM to the RX and TX baseband modules. The MAC provides hardware-based IEEE 802.15.4-2003 packet-level filtering. It supplies an accurate symbol time base that minimizes the synchronization effort of the Ember software and meets the protocol timing requirements. In addition, it provides timer and synchronization assistance for the IEEE 802.15.4-2003 CSMA-CA algorithm.

The EM341 integrates hardware support for a packet trace module, which allows robust packet-based debug. This element is a critical component of Ember Desktop, the Ember development environment, and provides advanced network debug capability when used with the Ember Debug Adapter (ISA3).

The EM341 integrates an ARM<sup>®</sup> Cortex<sup>™</sup>-M3 microprocessor, revision r1p1. This industry-leading core provides 32-bit performance and is very power-efficient. It has excellent code density using the ARM<sup>®</sup> Thumb-2 instruction

set. The processor can be operated at 12 or 24 MHz when using the high-frequency crystal oscillator, or at 6 MHz or 12 MHz when using the high-frequency internal RC oscillator.

The EM341 has 128 kB of flash memory. The chip has 12 kB of RAM on-chip, and the ARM configurable memory protection unit (MPU).

The EM341 implements both the ARM Serial Wire and JTAG debug interfaces. These interfaces provide real time, non-intrusive programming and debugging capabilities. Serial Wire and JTAG provide the same functionality, but are mutually exclusive. The Serial Wire interface uses two pins; the JTAG interface uses five. Serial Wire is preferred, since it uses fewer pins.

The EM341 contains 24 GPIO pins shared with other peripheral or alternate functions. Because of flexible routing within the EM341, external devices can use the alternate functions on a variety of different GPIOs. The integrated serial controller SC1 can be configured for SPI (master or slave), TWI (master-only), or UART operation, and the serial controller SC2 can be configured for SPI (master or slave) or TWI (master-only) operation.

The EM341 has a general purpose ADC which can sample analog signals from six GPIO pins in single-ended or differential modes. It can also sample the 1.8 V regulated supply VDD\_PADSA, the voltage reference VREF, and GND. The ADC has one voltage range: 0 to 1.2 V (normal). The ADC has a DMA mode to capture samples and automatically transfer them into RAM. The integrated voltage reference for the ADC, VREF, can be made available to external circuitry. The regulator input voltage, VDD\_PADS, cannot be measured using the general purpose ADC, but it can be measured through Ember software.

The EM341 contains four oscillators: a high-frequency 24 MHz external crystal oscillator, a high-frequency 12 MHz internal RC oscillator, an optional low-frequency 32.768 kHz external crystal oscillator, and a low-frequency 10 kHz internal RC oscillator.

The EM341 has an ultra low power, deep sleep state with a choice of clocking modes. The sleep timer can be clocked with either the external 32.768 kHz crystal oscillator or with a 1 kHz clock derived from the internal 10 kHz RC oscillator. Alternatively, all clocks can be disabled for the lowest power mode. In the lowest power mode, only external events on GPIO pins will wake up the chip. The EM341 has a fast startup time (typically 110  $\mu$ s) from deep sleep to the execution of the first ARM<sup>®</sup> Cortex<sup>™</sup>-M3 instruction.

The EM341 contains three power domains. The always-on high voltage supply powers the GPIO pads and critical chip functions. Regulated low voltage supplies power the rest of the chip. The low voltage supplies are disabled during deep sleep to reduce power consumption. Integrated voltage regulators generate regulated 1.25 V and 1.8 V voltages from an unregulated supply voltage. The 1.8 V regulator output is decoupled and routed externally to supply analog blocks, RAM, and flash memories. The 1.25 V regulator output is decoupled externally and supplies the core logic.

## 4. Radio Module

The radio module consists of an analog front end and digital baseband as shown in Figure 3.1 on page 22.

### 4.1. Receive (RX) Path

The RX path uses a low-IF, super-heterodyne receiver that rejects the image frequency using complex mixing and polyphase filtering. In the analog domain, the input RF signal from the antenna is first amplified and mixed down to a 4 MHz IF frequency. The mixers' output is filtered, combined, and amplified before being sampled by a 12 MSPS ADC. The digitized signal is then demodulated in the digital baseband. The filtering within the RX path improves the EM341's co-existence with other 2.4 GHz transceivers such as Zigbee/ 802.15.4-2003, IEEE 802.11-2007, and Bluetooth radios. The digital baseband also provides gain control of the RX path, both to enable the reception of small and large wanted signals and to tolerate large interferers.

#### 4.1.1. RX Baseband

The EM341 RX digital baseband implements a coherent demodulator for optimal performance. The baseband demodulates the O-QPSK signal at the chip level and synchronizes with the IEEE 802.15.4-2003-defined preamble. An automatic gain control (AGC) module adjusts the analog gain continuously every  $\frac{1}{4}$  symbol until the preamble is detected. Once detected, the gain is fixed for the remainder of the packet. The baseband despreads the demodulated data into 4-bit symbols. These symbols are buffered and passed to the hardware-based MAC module for packet assembly and filtering.

In addition, the RX baseband provides the calibration and control interface to the analog RX modules, including the LNA, RX baseband filter, and modulation modules. The Ember software includes calibration algorithms that use this interface to reduce the effects of silicon process and temperature variation.

#### 4.1.2. RSSI and CCA

The EM341 calculates the RSSI over every 8-symbol period as well as at the end of a received packet. The linear range of RSSI is specified to be at least 40 dB over temperature. At room temperature, the linear range is approximately 60 dB (–90 dBm to –30 dBm input signal).

The EM341 RX baseband provides support for the IEEE 802.15.4-2003 RSSI CCA method. Clear channel reports busy medium if RSSI exceeds its threshold.

### 4.2. Transmit (TX) Path

The EM341 TX path produces an O-QPSK-modulated signal using the analog front end and digital baseband. The area- and power-efficient TX architecture uses a two-point modulation scheme to modulate the RF signal generated by the synthesizer. The modulated RF signal is fed to the integrated PA and then out of the EM341.

#### 4.2.1. TX Baseband

The EM341 TX baseband in the digital domain spreads the 4-bit symbol into its IEEE 802.15.4-2003-defined 32-chip sequence. It also provides the interface for the Ember software to calibrate the TX module to reduce silicon process, temperature, and voltage variations.

#### 4.2.2. TX\_ACTIVE and nTX\_ACTIVE Signals

For applications requiring an external PA, two signals are provided called TX\_ACTIVE and nTX\_ACTIVE. These signals are the inverse of each other. They can be used for external PA power management and RF switching logic. In transmit mode the TX baseband drives TX\_ACTIVE high, as described in Table 7.5 on page 55. In receive mode the TX\_ACTIVE signal is low. TX\_ACTIVE is the alternate function of PC5, and nTX\_ACTIVE is the alternate function of PC6. See "7. GPIO (General Purpose Input/Output)" on page 48 for details of the alternate GPIO functions. The digital I/O that provide these signals have a 4 mA output sink and source capability.

### 4.3. Calibration

The Ember software calibrates the radio using dedicated hardware resources.



#### 4.4. Integrated MAC Module

The EM341 integrates most of the IEEE 802.15.4-2003 MAC requirements in hardware. This allows the ARM<sup>®</sup> Cortex<sup>™</sup>-M3 CPU to provide greater bandwidth to application and network operations. In addition, the hardware acts as a first-line filter for unwanted packets. The EM341 MAC uses a DMA interface to RAM to further reduce the overall ARM<sup>®</sup> Cortex<sup>™</sup>-M3 CPU interaction when transmitting or receiving packets.

When a packet is ready for transmission, the Ember software configures the TX MAC DMA by indicating the packet buffer RAM location. The MAC waits for the backoff period, then switches the baseband to TX mode and performs channel assessment. When the channel is clear the MAC reads data from the RAM buffer, calculates the CRC, and provides 4-bit symbols to the baseband. When the final byte has been read and sent to the baseband, the CRC remainder is read and transmitted.

The MAC is in RX mode most of the time. In RX mode various format and address filters keep unwanted packets from using excessive RAM buffers, and prevent the CPU from being unnecessarily interrupted. When the reception of a packet begins, the MAC reads 4-bit symbols from the baseband and calculates the CRC. It then assembles the received data for storage in a RAM buffer. RX MAC DMA provides direct access to RAM. Once the packet has been received additional data, which provides statistical information on the packet to the Ember software, is appended to the end of the packet in the RAM buffer space.

The primary features of the MAC are as follows:

- CRC generation, appending, and checking
- Hardware timers and interrupts to achieve the MAC symbol timing
- Automatic preamble and SFD pre-pending on TX packets
- Address recognition and packet filtering on RX packets
- Automatic acknowledgment transmission
- Automatic transmission of packets from memory
- Automatic transmission after backoff time if channel is clear (CCA)
- Automatic acknowledgment checking
- Time stamping received and transmitted messages
- Attaching packet information to received packets (LQI, RSSI, gain, time stamp, and packet status)
- IEEE 802.15.4-2003 timing and slotted/unslotted timing

#### 4.5. Packet Trace Interface (PTI)

The EM341 integrates a true PHY-level PTI for effective network-level debugging. It monitors all the PHY TX and RX packets between the MAC and baseband modules without affecting their normal operation. It cannot be used to inject packets into the PHY/MAC interface. This 500 kbps asynchronous interface comprises the frame signal (PTI\_EN, PA4) and the data signal (PTI\_DATA, PA5). PTI is supported by the Ember development tools.

#### 4.6. Random Number Generator

Thermal noise in the analog circuitry is digitized to provide entropy for a true random number generator (TRNG). The TRNG produces 16-bit uniformly distributed numbers. The Ember software uses the TRNG to seed a pseudo random number generator (PRNG). The TRNG is also used directly for cryptographic key generation.

## 5. ARM<sup>®</sup> Cortex<sup>™</sup>-M3 and Memory Modules

This chapter discusses the ARM<sup>®</sup> Cortex<sup>™</sup>-M3 Microprocessor, and reviews the EM341's flash and RAM memory modules as well as the Memory Protection Unit (MPU).

### 5.1. ARM<sup>®</sup> Cortex<sup>™</sup>-M3 Microprocessor

The EM341 integrates the ARM<sup>®</sup> Cortex<sup>™</sup>-M3 microprocessor, revision r1p1, developed by ARM Ltd., making the EM341 a true System-on-Chip solution. The ARM<sup>®</sup> Cortex<sup>™</sup>-M3 is an advanced 32-bit modified Harvard architecture processor that has separate internal program and data buses, but presents a unified program and data address space to software. The word width is 32 bits for both the program and data sides. The ARM<sup>®</sup> Cortex<sup>™</sup>-M3 allows unaligned word and half-word data accesses to support efficiently-packed data structures.

The ARM<sup>®</sup> Cortex<sup>™</sup>-M3 in the EM341 has also been enhanced to support two separate memory protection levels. Basic protection is available without using the MPU, but normal operation uses the MPU. The MPU allows for protecting unimplemented areas of the memory map to prevent common software bugs from interfering with software operation. The architecture could also allow for separation of the networking stack from the application code using a fine granularity RAM protection module. Errant writes are captured and details are reported to the developer to assist in tracking down and fixing issues.

### 5.2. Embedded Memory

Figure 5.1 shows the EM341 ARM<sup>®</sup> Cortex<sup>™</sup>-M3 memory map.

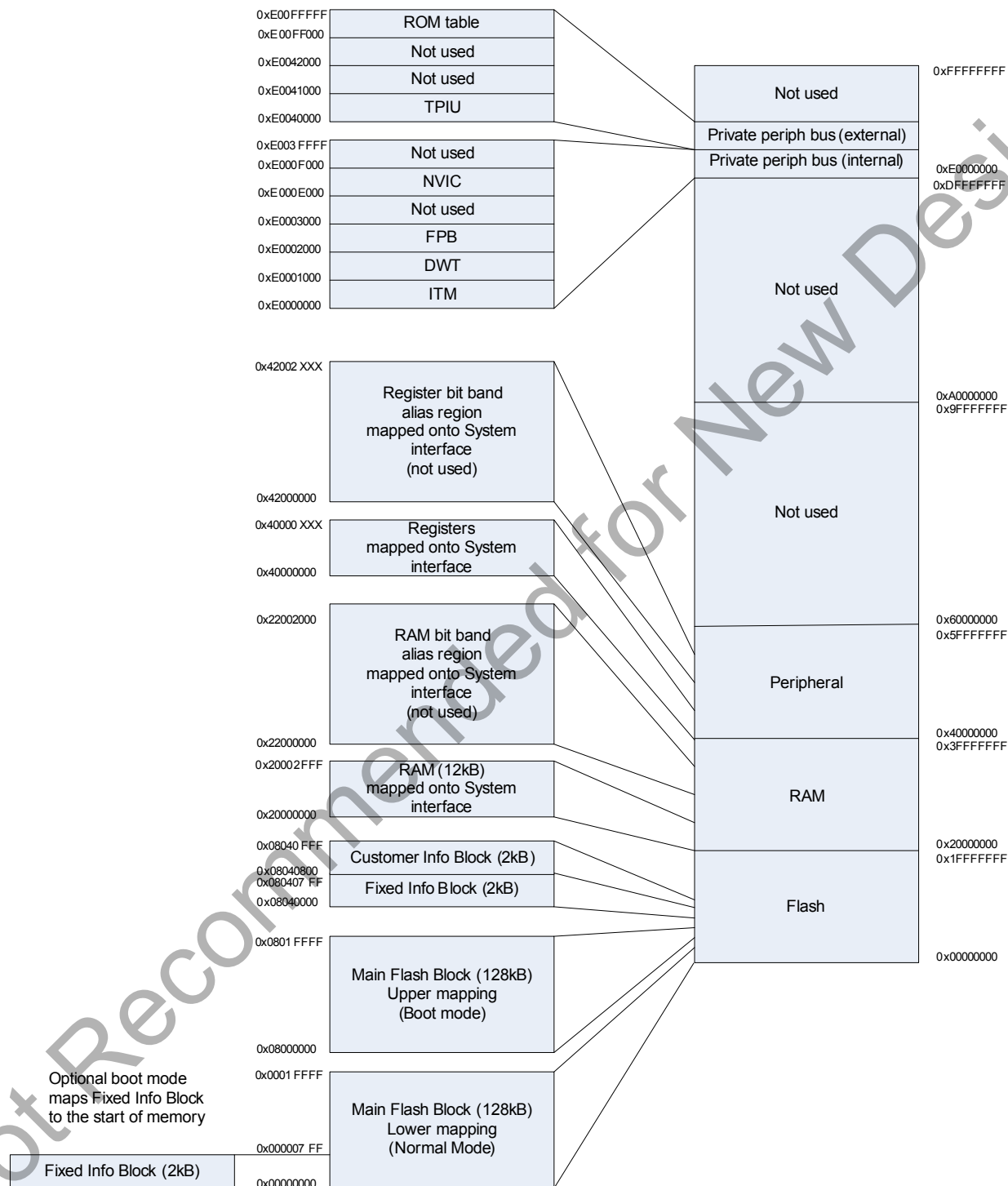

Figure 5.1. EM341 ARM® Cortex™-M3 Memory Map

## 5.2.1. Flash Memory

### 5.2.1.1. Flash Overview

The EM341 provides a total of 128 kB of flash memory. The flash memory is provided in three separate blocks:

- Main Flash Block (MFB)
- Fixed Information Block (FIB)
- Customer Information Block (CIB)

The MFB is divided into 2048-byte pages. The EM341 has 64 pages. The CIB is a single 2048-byte page. The FIB is a single 2048-byte page. The smallest erasable unit is one page and the smallest writable unit is an aligned 16-bit half-word. The flash is rated to have a guaranteed 20,000 write/erase cycles. The flash cell has been qualified for a data retention time of >100 years at room temperature.

Flash may be programmed either through the Serial Wire/JTAG interface or through bootloader software. Programming flash through Serial Wire/JTAG requires the assistance of RAM-based utility code. Programming through a bootloader requires Ember software for over-the-air loading or serial link loading.

#### 5.2.1.2. Main Flash Block

The start of the MFB is mapped to both address 0x00000000 and address 0x08000000 in normal boot mode, but is mapped only to address 0x08000000 in FIB monitor mode (see also "7.5. Boot Configuration" on page 51). Consequently, it is recommended that software intended to execute from the MFB is designed to operate from the upper address, 0x08000000, since this address mapping is always available in all modes.

The MFB stores all program instructions and constant data. A small portion of the MFB is devoted to non-volatile token storage using the Ember Simulated EEPROM system.

#### 5.2.1.3. Fixed Information Block

The 2 kB FIB is used to store fixed manufacturing data including serial numbers and calibration values. The start of the FIB is mapped to address 0x08040000. This block can only be programmed during production by Silicon Labs.

The FIB also contains a monitor program, which is a serial-link-only way of performing low-level memory accesses. In FIB monitor mode (see "7.5. Boot Configuration" on page 51), the start of the FIB is mapped to both address 0x00000000 and address 0x08040000 so the monitor may be executed out of reset.

#### 5.2.1.4. Customer Information Block

The 2048 byte CIB can be used to store customer data. The start of the CIB is mapped to address 0x08040800. The CIB cannot be executed.

The first eight half-words of the CIB are dedicated to special storage called option bytes. An option byte is a 16 bit quantity of flash where the lower 8 bits contain the data and the upper 8 contain the inverse of the lower 8 bits. The upper 8 bits are automatically generated by hardware and cannot be written to by the user, see Table 5.1.

The option byte hardware also verifies the inverse of each option byte when exiting from reset and generates an error, which prevents the CPU from executing code, if a discrepancy is found. All of this is transparent to the user.

Table 5.1. Option Byte Storage

Address	bits [15:8]	bits [7:0]	Notes
0x08040800	Inverse Option Byte 0	Option Byte 0	Configures flash read protection
0x08040802	Inverse Option Byte 1	Option Byte 1	Reserved
0x08040804	Inverse Option Byte 2	Option Byte 2	Available for customer use <sup>1</sup>
0x08040806	Inverse Option Byte 3	Option Byte 3	Available for customer use <sup>1</sup>
0x08040808	Inverse Option Byte 4	Option Byte 4	Configures flash write protection
0x0804080A	Inverse Option Byte 5	Option byte 5	Configures flash write protection
0x0804080C	Inverse Option Byte 6	Option Byte 6	Reserved
0x0804080E	Inverse Option Byte 7	Option Byte 7	Reserved
<b>Notes:</b>			
1. Option bytes 2 and 3 do not link to any specific hardware functionality other than the option byte loader. Therefore, they are best used for storing data that requires a hardware verification of the data integrity.			

Table 5.2 shows the mapping of the option bytes that are used for read and write protection of the flash. Each bit of the flash write protection option bytes protects a 4 page region of the main flash block. The EM341 has 16 regions and therefore option bytes 4 and 5 control flash write protection (option byte 6 is reserved/unused). These write protection bits are active low, and therefore the erased state of 0xFF disables write protection. Like read protection, write protection only takes effect after a reset. Write protection not only prevents a write to the region, but also prevents page erasure.

Option byte 0 controls flash read protection. When option byte 0 is set to 0xA5, read protection is disabled. All other values, including the erased state 0xFF, enable read protection when coming out of reset. The internal state of read protection (active versus disabled) can only be changed by applying a full chip reset. If a debugger is connected to the EM341, the intrusion state is latched. Read protection is combined with this latched intrusion signal. When both read protection and intrusion are set, all flash is disconnected from the internal bus. As a side effect, the CPU cannot execute code since all flash is disconnected from the bus. This functionality prevents a debug tool from being able to read the contents of any flash. The only means of clearing the intrusion signal is to disconnect the debugger and reset the entire chip using the nRESET pin. By requiring a chip reset, a debugger cannot install or execute malicious code that could allow the contents of the flash to be read.

The only way to disable read protection is to program option byte 0 with the value 0xA5. Option byte 0 must be erased before it can be programmed. Erasing option byte 0 while read protection is active automatically mass-erases the main flash block. By automatically erasing main flash, a debugger cannot disable read protection and readout the contents of main flash without destroying its contents.

When read protection is active, the bottom four flash pages, addresses 0x08000000 to 0x08001FFF, are automatically write-protected. Write protecting the bottom four flash pages of main flash prevents an attacker from reprogramming the reset vector and executing arbitrary code.

In general, if read protection is active then write protection should also be active. This prevents an attacker from reprogramming flash with malicious code that could readout the flash after the debugger is disconnected. Even though read protection automatically protects the reset vector, the same technique of reprogramming flash could be performed at an address outside the bottom four flash pages. To obtain fully protected flash, both read protection and write protection should be active.

Table 5.2. Option Byte Write Protection Bit Map

Option Byte	Bit	Notes
Option Byte 0	bit [7:0]	Read protection of all flash (MFB, FIB, CIB)
Option Byte 1	bit [7:0]	Reserved for Silicon Labs use
Option Byte 2	bit [7:0]	Available for customer use
Option Byte 3	bit [7:0]	Available for customer use
Option Byte 4	bit [0]	Write protection of address range 0x08000000 – 0x08001FFF
	bit [1]	Write protection of address range 0x08002000 – 0x08003FFF
	bit [2]	Write protection of address range 0x08004000 – 0x08005FFF
	bit [3]	Write protection of address range 0x08006000 – 0x08007FFF
	bit [4]	Write protection of address range 0x08008000 – 0x08009FFF
	bit [5]	Write protection of address range 0x0800A000 – 0x0800BFFF
	bit [6]	Write protection of address range 0x0800C000 – 0x0800DFFF
	bit [7]	Write protection of address range 0x0800E000 – 0x0800FFFF
Option Byte 5	bit [0]	Write protection of address range 0x08010000 – 0x08011FFF
	bit [1]	Write protection of address range 0x08012000 – 0x08013FFF
	bit [2]	Write protection of address range 0x08014000 – 0x08015FFF
	bit [3]	Write protection of address range 0x08016000 – 0x08017FFF
	bit [4]	Write protection of address range 0x08018000 – 0x08019FFF
	bit [5]	Write protection of address range 0x0801A000 – 0x0801BFFF
	bit [6]	Write protection of address range 0x0801C000 – 0x0801DFFF
	bit [7]	Write protection of address range 0x0801E000 – 0x0801FFFF
Option Byte 6	bit[7:0]	Unused
Option Byte 7	bit [7:0]	Reserved for Silicon Labs use

### 5.2.1.5. Simulated EEPROM

Ember software reserves 8 kB of the main flash block as a simulated EEPROM storage area for stack and customer tokens. The simulated EEPROM storage area implements a wear-leveling algorithm to extend the number of simulated EEPROM write cycles beyond the physical limit of 20,000 write cycles for which each flash cell is qualified.

## 5.2.2. RAM

### 5.2.2.1. RAM Overview

The EM341 has 12 kB of static RAM on-chip. The start of RAM is mapped to address 0x20000000. Although the ARM® Cortex™-M3 allows bit band accesses to this address region, the standard MPU configuration does not permit use of the bit-band feature.

The RAM is physically connected to the AHB System bus and is therefore accessible to both the ARM® Cortex™-M3 microprocessor and the debugger. The RAM can be accessed for both instruction and data fetches as bytes, half words, or words. The standard MPU configuration does not permit execution from the RAM, but for special purposes the MPU may be disabled. To the bus, the RAM appears as 32-bit wide memory and in most situations has zero wait state read or write access. In the higher CPU clock mode the RAM requires two wait states. This is handled by hardware transparent to the user application with no configuration required.

### 5.2.2.2. Direct Memory Access (DMA) to RAM

Several of the peripherals are equipped with DMA controllers allowing them to transfer data into and out of RAM autonomously. This applies to the radio (802.15.4-2003 MAC), general purpose ADC, and both serial controllers. In the case of the serial controllers, the DMA is full duplex so that a read and a write to RAM may be requested at the same time. Thus there are six DMA channels in total. See "8.7. DMA Channels" on page 99 and "10.1.4. DMA" on page 173 for a description of how to configure the serial controllers and ADC for DMA operation. The DMA channels do not use AHB system bus bandwidth as they access the RAM directly.

The EM341 integrates a DMA arbiter that ensures fair access to the microprocessor as well as the peripherals through a fixed priority scheme appropriate to the memory bandwidth requirements of each master. The priority scheme is as follows, with the top peripheral being the highest priority:

1. General Purpose ADC
2. Serial Controller 2 Receive
3. Serial Controller 2 Transmit
4. MAC
5. Serial Controller 1 Receive
6. Serial Controller 1 Transmit

### 5.2.2.3. RAM Memory Protection

The EM341 integrates two memory protection mechanisms. The first memory protection mechanism is through the ARM® Cortex™-M3 Memory Protection Unit (MPU) described in "5.3. Memory Protection Unit". The MPU may be used to protect any area of memory. MPU configuration is normally handled by Ember software. The second memory protection mechanism is through a fine granularity RAM protection module. This allows segmentation of the RAM into 32-byte blocks where any block can be marked as write protected. An attempt to write to a protected RAM block using a user mode write results in a bus error being signaled on the AHB System bus. A privileged mode write is allowed at any time and reads are allowed in either mode. The main purpose of this fine granularity RAM protection module is to notify the software of erroneous writes to system areas of memory. RAM protection is configured using a group of registers that provide a bit map. Each bit in the map represents a 32-byte block of RAM. When the bit is set the block is write-protected.

The fine granularity RAM memory protection mechanism is also available to the peripheral DMA controllers. A register bit enables protection from DMA writes to protected memory. If a DMA write is made to a protected location in RAM, a management interrupt is generated. At the same time the faulting address and the identification of the peripheral is captured for later debugging. Note that only peripherals capable of writing data to RAM, such as received packet data or a received serial port character, can generate this interrupt.

## 5.2.3. Registers

Appendix A, Register Address Table provides a short description of all application-accessible registers within the EM341. Complete descriptions are provided at the end of each applicable peripheral's description. The registers are mapped to the system address space starting at address 0x40000000. These registers allow for the control and configuration of the various peripherals and modules. The CPU only performs word-aligned accesses on the system bus. The CPU performs a word aligned read-modify-write for all byte, half-word, and unaligned writes and a word-aligned read for all reads. Silicon Labs recommends accessing all peripheral registers using word-aligned addressing.

As with the RAM, the peripheral registers fall within an address range that allows for bit-band access by the ARM® Cortex™-M3, but the standard MPU configuration does not allow access to this alias address range.

## 5.3. Memory Protection Unit

The EM341 includes the ARM® Cortex™-M3 Memory Protection Unit, or MPU. The MPU controls access rights and characteristics of up to eight address regions, each of which may be divided into eight equal sub-regions. Refer to the ARM® Cortex™-M3 Technical Reference Manual (DDI 0337A) for a detailed description of the MPU.

Ember software configures the MPU in a standard configuration and application software should not modify it. The configuration is designed for optimal detection of illegal instruction or data accesses. If an illegal access is attempted, the MPU captures information about the access type, the address being accessed, and the location of the offending software. This simplifies software debugging and increases the reliability of deployed devices. As a consequence of this MPU configuration, accessing RAM and register bit-band address alias regions is not permitted, and generates a bus fault if attempted.



## 6. System Modules

System modules encompass power domains, resets, clocks, system timers, power management, and encryption. Figure 6.1 shows these modules and how they interact.

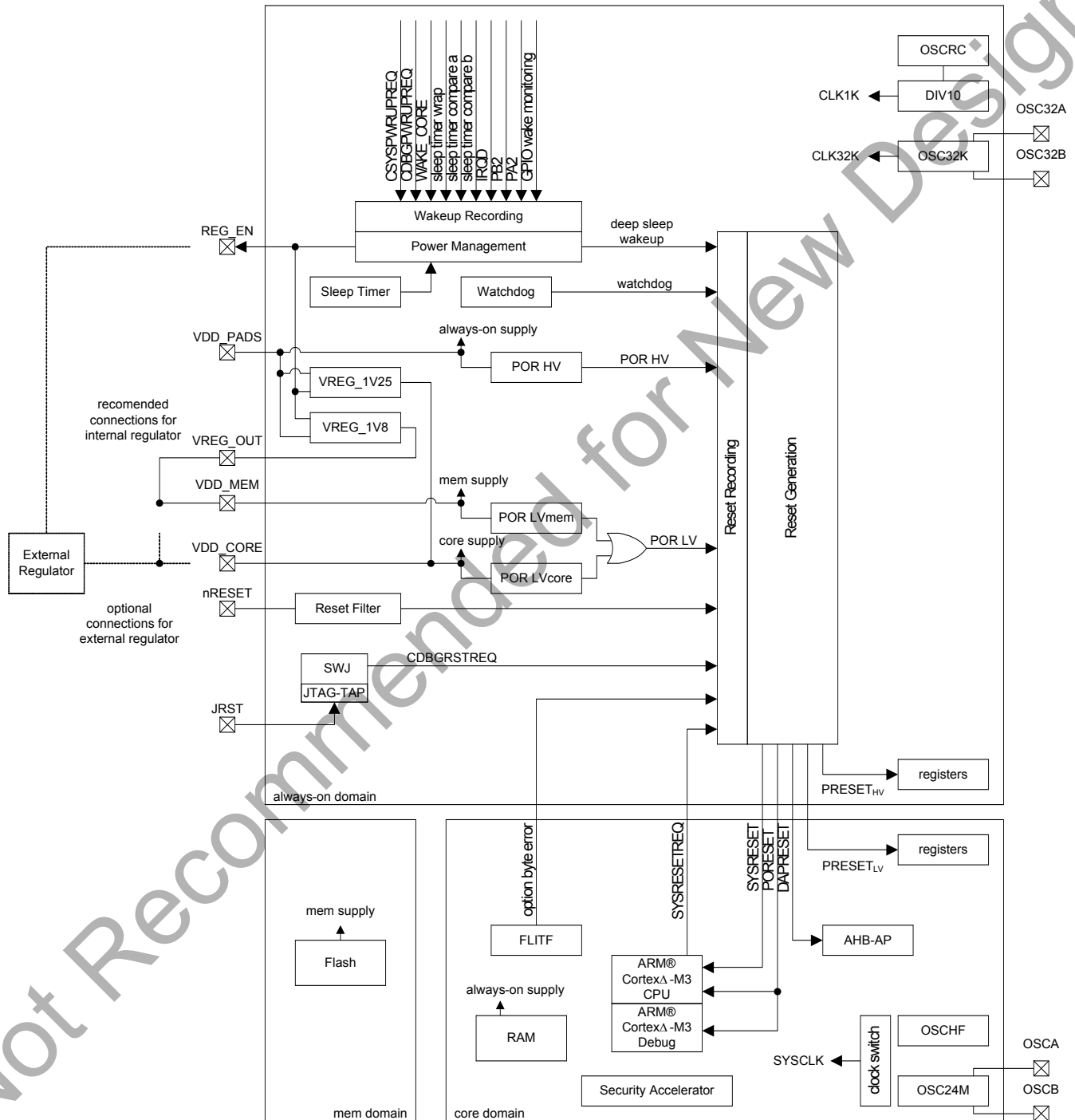

Figure 6.1. System Module Block Diagram

## 6.1. Power Domains

The EM341 contains three power domains:

- An “always-on domain” containing all logic and analog cells required to manage the EM341’s power modes, including the GPIO controller and sleep timer. This domain must remain powered.
- A “core domain” containing the CPU, Nested Vectored Interrupt Controller (NVIC), and peripherals. To save power, this domain can be powered down using a mode called deep sleep.
- A “memory domain” containing the RAM and flash memories. This domain is managed by the power management controller. When in deep sleep, the RAM portion of this domain is powered from the always-on domain supply to retain the RAM contents while the regulators are disabled. During deep sleep the flash portion is completely powered down.

### 6.1.1. Internally Regulated Power

The preferred and recommended power configuration is to use the internal regulated power supplies to provide power to the core and memory domains. The internal regulators (VREG\_1V25 and VREG\_1V8) generate nominal 1.25 and 1.8 V supplies. The 1.25 V supply is internally routed to the core domain and to an external pin. The 1.8 V supply is routed to an external pin where it can be externally routed back into the chip to supply the memory domain. The internal regulators are described in “14. Integrated Voltage Regulator” on page 117.

When using the internal regulators, the always-on domain must be powered between 2.1 and 3.6 V at all four VDD\_PADS pins.

When using the internal regulators, the VREG\_1V8 regulator output pin (VREG\_OUT) must be connected to the VDD\_MEM, VDD\_PADSA, VDD\_VCO, VDD\_RF, VDD\_IF, VDD\_PRE, and VDD\_SYNTH pins.

When using the internal regulators, the VREG\_1V25 regulator output and supply requires a connection between both VDD\_CORE pins.

### 6.1.2. Externally Regulated Power

Optionally, the on-chip regulators may be left unused, and the core and memory domains may instead be powered from external supplies. For simplicity, the voltage for the core domain can be raised to nominal 1.8 V, requiring only one external regulator, or the core domain can be powered from the on-chip regulators while the other domains are powered externally. Note that if the core domain is powered at a higher voltage (1.8 V instead of 1.25 V) then power consumption increases. A regulator enable signal, REG\_EN, is provided for control of external regulators. This is an open-drain signal that requires an external pull-up resistor. If REG\_EN is not required to control external regulators it can be disabled (see “7.3. Forced Functions” on page 50).

Using an external regulator requires the always-on domain to be powered between 2.1 and 3.6 V at all four VDD\_PADS pins.

When using an external regulator, the VREG\_1V8 regulator output pin (VREG\_OUT) must be left unconnected.

When using an external regulator, this external nominal 1.8 V supply has to be connected to both VDD\_CORE pins and to the VDD\_MEM, VDD\_PADSA, VDD\_VCO, VDD\_RF, VDD\_IF, VDD\_PRE and VDD\_SYNTH pins.

## 6.2. Resets

The EM341 resets are generated from a number of sources. Each of these reset sources feeds into central reset detection logic that causes various parts of the system to be reset depending on the state of the system and the nature of the reset event.

### 6.2.1. Reset Sources

#### 6.2.1.1. Power-On-Resets (POR HV and POR LV)

The EM341 measures the voltage levels supplied to the three power domains. If a supply voltage drops below a low threshold, then a reset is applied. The reset is released if the supply voltage rises above a high threshold. There are three detection circuits for power-on-reset as follows:

- POR HV monitors the always-on domain supply voltage. Thresholds are given in Table 6.1.
- POR LV core monitors the core domain supply voltage. Thresholds are given in Table 6.2.
- POR LV mem monitors the memory supply voltage. Thresholds are given in Table 6.3.

**Table 6.1. POR HV Thresholds**

Parameter	Test conditions	Min	Typ	Max	Unit
Always-on domain release		0.62	0.95	1.20	V
Always-on domain assert		0.45	0.65	0.85	V
Supply rise time	From 0.5 V to 1.7 V			250	μs

**Table 6.2. POR LVcore Thresholds**

Parameter	Test conditions	Min	Typ	Max	Unit
1.25 V domain release		0.9	1.0	1.1	V
1.25 V domain assert		0.8	0.9	1.0	V

**Table 6.3. POR LVmem Thresholds**

Parameter	Test conditions	Min	Typ	Max	Unit
1.8 V domain release		1.35	1.5	1.65	V
1.8 V domain assert		1.26	1.4	1.54	V

The POR LVcore and POR LVmem reset sources are merged to provide a single reset source, POR LV, to the Reset Generation module, since the detection of either event needs to reset the same system modules.

## 6.2.1.2. nRESET Pin

A single active low pin, nRESET, is provided to reset the system. This pin has a Schmitt triggered input.

To afford good noise immunity and resistance to switch bounce, the pin is filtered with the Reset Filter module and generates the pin reset source, nRESET, to the Reset Generation module. Table 6.4 contains the specification for the filter.

**Table 6.4. Reset Filter Specification for nRESET**

Parameter	Min	Typ	Max	Unit
Reset filter time constant	2.1	12.0	16.0	µs
Reset pulse width to guarantee a reset	26.0	—	—	µs
Reset pulse width guaranteed not to cause a reset	0	—	1.0	µs

## 6.2.1.3. Watchdog Reset

The EM341 contains a watchdog timer (see also "6.4.1. Watchdog Timer" on page 42) that is clocked by the internal 1 kHz timing reference. When the timer expires it generates the reset source WATCHDOG\_RESET to the Reset Generation module.

## 6.2.1.4. Software Reset

The ARM® Cortex™-M3 CPU can initiate a reset under software control. This is indicated with the reset source SYSRESETREQ to the Reset Generation module.

## 6.2.1.5. Option Byte Error

The flash memory controller contains a state machine that reads configuration information from the information blocks in the flash at system start time. An error check is performed on the option bytes that are read from flash and, if the check fails, an error is signaled that provides the reset source OPT\_BYTE\_ERROR to the Reset Generation module.

If an option byte error is detected, the system restarts and the read and check process is repeated. If the error is detected again the process is repeated but stops on the 3<sup>rd</sup> failure. The system is then placed into an emulated deep sleep where recovery is possible. In this state, flash memory readout protection is forced active to prevent secure applications from being compromised.

## 6.2.1.6. Debug Reset

The Serial Wire/JTAG Interface (SWJ) provides access to the SWJ Debug Port (SWJ-DP) registers. By setting the register bit CDBGRSTREQ in the SWJ-DP, the reset source CDBGRSTREQ is provided to the Reset Generation module.

## 6.2.1.7. JRST

One of the EM341's pins can function as the JTAG reset, conforming to the requirements of the JTAG standard. This input acts independently of all other reset sources and, when asserted, does not reset any on-chip hardware except for the JTAG TAP. If the EM341 is in the Serial Wire mode or if the SWJ is disabled, this input has no effect.

### 6.2.1.8. Deep Sleep Reset

The Power Management module informs the Reset Generation module of entry into and exit from the deep sleep states. The deep sleep reset is applied in the following states: before entry into deep sleep, while removing power from the memory and core domain, while in deep sleep, while waking from deep sleep, and while reapplying power until reliable power levels have been detected by POR LV.

The Power Management module allows a special emulated deep sleep state that retains memory and core domain power while in deep sleep.

### 6.2.2. Reset Recording

The EM341 records the last reset condition that generated a restart to the system. The reset conditions recorded are as follows:

- POR HV                      always-on domain power supply failure
- POR LV                      core domain (POR LVcore) or memory domain (POR LVmem) power supply failure
- nRESET                      pin reset asserted
- watchdog                    watchdog timer expired
- SYSRESETREQ              software reset by SYSERSETREQ from ARM® Cortex™-M3 CPU
- deep sleep wakeup        wake-up from deep sleep
- option byte error         error check failed when reading option bytes from flash

**Note:** While CPU Lockup is shown as a reset condition in software, CPU Lockup is not specifically a reset event. CPU Lockup is set to indicate that the CPU entered an unrecoverable exception. Execution stops but a reset is not applied. This is so that a debugger can interpret the cause of the error. Silicon Labs recommends that in a live application (in other words, no debugger attached) the watchdog be enabled by default so that the EM341 can be restarted.

### 6.2.3. Reset Generation Module

The Reset Generation module responds to reset sources and generates the following reset signals:

- PORESET                    Reset of the ARM® Cortex™-M3 CPU and ARM® Cortex™-M3 System Debug components (Flash Patch and Breakpoint, Data Watchpoint and Trace, Instrumentation Trace Macrocell, Nested Vectored Interrupt Controller). ARM defines PORESET as the region that is reset when power is applied.
- SYSRESET                    Reset of the ARM® Cortex™-M3 CPU without resetting the Core Debug and System Debug components, so that a live system can be reset without disturbing the debug configuration.
- DAPRESET                    Reset to the SWJ's AHB Access Port (AHB-AP)
- PRESET<sub>HV</sub>                  Peripheral reset for always-on power domain, for peripherals that are required to retain their configuration across a deep sleep cycle
- PRESET<sub>LV</sub>                  Peripheral reset for core power domain, for peripherals that are not required to retain their configuration across a deep sleep cycle

Table 6.5 shows which reset sources generate certain resets.

**Table 6.5. Generated Resets**

Reset Source	Reset Generation Module Output				
	PORESET	SYSRESET	DAPRESET	PRESET <sub>HV</sub>	PRESET <sub>LV</sub>
POR HV	X	X	X	X	X
POR LV (due to waking from normal deep sleep)	X	X	X		X
POR LV (not due to waking from normal deep sleep)	X	X	X	X	X
nRESET	X	X		X	X
Watchdog		X		X	X
SYSRESETREQ		X		X	X
Option byte error	X	X			X
Normal deep sleep	X	X	X		X
Emulated deep sleep		X			X
Debug reset		X			

### 6.3. Clocks

The EM341 integrates four oscillators:

- 12 MHz RC oscillator
- 24 MHz crystal oscillator
- 10 kHz RC oscillator
- 32.768 kHz crystal oscillator

Figure 6.2 shows a block diagram of the clocks in the EM341. This simplified view shows all the clock sources and the general areas of the chip to which they are routed.

**Figure 6.2. Clocks Block Diagram**

### 6.3.1. High-Frequency Internal RC Oscillator (OSCHF)

The high-frequency RC oscillator (OSCHF) is used as the default system clock source when power is applied to the core domain. The nominal frequency coming out of reset is 12 MHz and Ember software calibrates this clock to 12 MHz. Table 6.6 contains the specification for the high frequency RC oscillator.

Most peripherals, excluding the radio peripheral, are fully functional using the OSCHF clock source. Application software must be aware that peripherals are clocked at different speeds depending on whether OSCHF or OSC24M is being used. Since the frequency step of OSCHF is 0.3 MHz and the high-frequency crystal oscillator is used for calibration, the calibrated accuracy of OSCHF is  $\pm 150$  kHz  $\pm 40$  ppm. The UART and ADC peripherals may not be usable due to the lower accuracy of the OSCHF frequency.

**Table 6.6. High-Frequency RC Oscillator Specification**

Parameter	Test Conditions	Min	Typ	Max	Unit
Frequency at reset		6	12	20	MHz
Frequency Steps		—	0.3	—	MHz
Duty cycle		40	—	60	%
Supply dependence	Change in supply = 0.1 V Test at supply changes: 1.8 to 1.7 V	—	—	5	%

### 6.3.2. High-Frequency Crystal Oscillator (OSC24M)

The high-frequency crystal oscillator (OSC24M) requires an external 24 MHz crystal with an accuracy of  $\pm 40$  ppm. Based upon the application's bill of materials and current consumption requirements, the external crystal may cover a range of ESR requirements. Table 6.7 contains the specification for the high frequency crystal oscillator.

The crystal oscillator has a software-programmable bias circuit to minimize current consumption. Ember software configures the bias circuit for minimum current consumption.

All peripherals including the radio peripheral are fully functional using the OSC24M clock source. Application software must be aware that peripherals are clocked at different speeds depending on whether OSCHF or OSC24M is being used.

If the 24 MHz crystal fails, a hardware failover mechanism forces the system to switch back to the high-frequency RC oscillator as the main clock source, and a non-maskable interrupt (NMI) is signaled to the ARM<sup>®</sup> Cortex<sup>™</sup>-M3 NVIC.

Table 6.7. High-Frequency Crystal Oscillator Specification

Parameter	Test Conditions	Min	Typ	Max	Unit
Frequency		—	24	—	MHz
Accuracy		-40	—	+40	ppm
Duty cycle		40	—	60	%
Start-up time at max bias		—	—	1	ms
Start up time at optimal bias		—	—	2	ms
Current consumption		—	200	300	μA
Current consumption at max bias		—	—	1	mA
Crystal with high ESR		—	—	100	Ω
Load capacitance		—	—	10	pF
Crystal capacitance		—	—	7	pF
Crystal power dissipation		—	—	200	μW
Crystal with low ESR		—	—	60	Ω
Load capacitance		—	—	18	pF
Crystal capacitance		—	—	7	pF
Crystal power dissipation		—	—	1	mW

### 6.3.3. Low-Frequency Internal RC Oscillator (OSCR)

A low-frequency RC oscillator (OSCR) is provided as an internal timing reference. The nominal frequency coming out of reset is 10 kHz, and Ember software calibrates this clock to 10 kHz. From the tuned 10 kHz oscillator (OSCR) Ember software calibrates a fractional-N divider to produce a 1 kHz reference clock, CLK1K. Table 6.8 contains the specification for the low frequency RC oscillator.

Table 6.8. Low-Frequency RC Oscillator Specification

Parameter	Test Condition	Min	Typ	Max	Unit
Nominal frequency	After trimming	9	10	11	kHz
Analog trim step size		—	0.5	—	kHz
Supply dependence	For a voltage drop from 3.6 V to 3.1 V or 2.6 V to 2.1 V (without re-calibration)	—	1	—	%
Temperature dependence	Frequency variation with temperature for a change from -40 to +85 °C (without re-calibration)	—	2	—	%



### 6.3.4. Low-Frequency Crystal Oscillator (OSC32K)

A low-frequency 32.768 kHz crystal oscillator (OSC32K) is provided as an optional timing reference for on-chip timers. This oscillator is designed for use with an external watch crystal. When using the 32.768 kHz crystal, you must connect it to GPIO PC6 and PC7 and must configure these two GPIOs for analog input. Alternatively, when PC7 is configured as a digital input, PC7 can accept an external digital clock input instead of a 32.768 kHz crystal. The digital clock input signal must be a 1 V peak-to-peak sine wave with a dc bias of 0.5 V. Refer to "7. GPIO (General Purpose Input/Output)" on page 48 for GPIO configuration details. Using the low-frequency oscillator, crystal or digital clock, is enabled through Ember software.

Table 6.9 contains the specification for the low frequency crystal oscillator.

**Table 6.9. Low-Frequency Crystal Oscillator Specification**

Parameter	Test conditions	Min	Typ	Max	Unit
Frequency		—	32.768	—	kHz
Accuracy	At 25 °C	-20	—	+20	ppm
Load capacitance OSC32A		—	27	—	pF
Load capacitance OSC32B		—	18	—	pF
Crystal ESR		—	—	100	kΩ
Start-up time		—	—	2	s
Current consumption	At 25 °C, VDD_PADS=3.0 V	—	—	0.5	μA

### 6.3.5. Clock Switching

The EM341 has two switching mechanisms for the main system clock, providing four clock modes. Table 6.10 shows these clock modes and how they affect the internal clocks.

The register bit OSC24M\_CTRL\_OSC24M\_SEL in the OSC24M\_CTRL register switches between the high-frequency RC oscillator (OSCHF) and the high-frequency crystal oscillator (OSC24M) as the main system clock (SYSCLK). The peripheral clock (PCLK) is always half the frequency of SYSCLK.

The register bit CPU\_CLKSEL\_FIELD in the CPU\_CLKSEL register switches between PCLK and SYSCLK to produce the ARM<sup>®</sup> Cortex<sup>™</sup>-M3 CPU clock (FCLK). The default and preferred mode of operation is to run the CPU at the higher PCLK frequency, 24 MHz, to give higher processing performance for all applications and improved duty cycling for applications using sleep modes.

In addition to these modes, further automatic control is invoked by hardware when flash programming is enabled. To ensure accuracy of the flash controller's timers, the FCLK frequency is forced to 12 MHz during flash programming and erase operations.

**Table 6.10. System Clock Modes**

OSC24M_CTRL_OSC24M_SEL	CPU_CLKSEL_FIELD	SYSCLK	PCLK	FCLK	
				Flash Program/ Erase Inactive	Flash Program/ Erase Active
0 (OSCHF)	0 (Normal CPU)	12 MHz	6 MHz	6 MHz	12 MHz
0 (OSCHF)	1 (Fast CPU)	12 MHz	6 MHz	12 MHz	12 MHz
1 (OSC24M)	0 (Normal CPU)	24 MHz	12 MHz	12 MHz	12 MHz
1 (OSC24M)	1 (Fast CPU)	24 MHz	12 MHz	24 MHz	12 MHz

## 6.4. System Timers

### 6.4.1. Watchdog Timer

The EM341 integrates a watchdog timer which can be enabled to provide protection against software crashes and ARM® Cortex™-M3 CPU lockup. By default, it is disabled at power up of the always-on power domain. The watchdog timer uses the calibrated 1 kHz clock (CLK1K) as its reference and provides a nominal 2.048 s timeout. A low water mark interrupt occurs at 1.792 s and triggers an NMI to the ARM® Cortex™-M3 NVIC as an early warning. When the watchdog is enabled, the timer must be periodically reset before it expires. The watchdog timer is paused when the debugger halts the ARM® Cortex™-M3. Additionally, the Ember software that implements deep sleep functionality disables the watchdog when entering deep sleep and restores the watchdog, if it was enabled, when exiting deep sleep.

Ember software provides an API for enabling, resetting, and disabling the watchdog timer.

### 6.4.2. Sleep Timer

The EM341 integrates a 32-bit timer dedicated to system timing and waking from sleep at specific times. The sleep timer can use either the calibrated 1 kHz reference (CLK1K), or the 32 kHz crystal clock (CLK32K). The default clock source is the internal 1 kHz clock.

The sleep timer has a prescaler, a divider of the form  $2^N$ , where N can be programmed from 1 to  $2^{15}$ . This divider allows for very long periods of sleep to be timed. Ember software's default configuration is to use the prescaler to always produce a 1024 Hz sleep timer tick. The timer provides two compare outputs and wrap detection, all of which can be used to generate an interrupt or a wake up event.

While it is possible to do so, by default the sleep timer is not paused when the debugger halts the ARM® Cortex™-M3. Silicon Labs does not advise pausing the sleep timer when the debugger halts the CPU.

To save current during deep sleep, the low-frequency internal RC oscillator (OSCRC) can be turned off. If OSCRC is turned off during deep sleep and a low-frequency 32.768 kHz crystal oscillator is not being used, then the sleep timer will not operate during deep sleep and sleep timer wake events cannot be used to wake up the EM341.

Ember software provides the system timer software API for interacting with the sleep timer as well as using the sleep timer and RC oscillator during deep sleep.

**Note:** Because the system timer software module handles all interactions with the sleep timer, the module will return the correct value in all situations. In the situation where the chip performs a deep sleep that maintains the system time and is woken up from an external event (that is, not a sleep timer event), the deep sleep module in the Ember software delays until the next sleep timer clock tick (up to 1 ms) to guarantee that the sleep timer updates correctly.

### 6.4.3. Event Timer

The SysTick timer is an ARM® standard system timer in the NVIC. The SysTick timer can be clocked from either the FCLK (the clock going into the CPU) or the Sleep Timer clock. FCLK is either the SYSCLK or PCLK as selected by CPU\_CLKSEL register (see "6.3.5. Clock Switching").

## 6.5. Power Management

The EM341's power management system is designed to achieve the lowest deep sleep current consumption possible while still providing flexible wakeup sources, timer activity, and debugger operation. The EM341 has four main sleep modes:

- Idle Sleep: Puts the CPU into an idle state where execution is suspended until any interrupt occurs. All power domains remain fully powered and nothing is reset.
- Deep Sleep 1: The primary deep sleep state. In this state, the core power domain is fully powered down and the sleep timer is active.
- Deep Sleep 2: The same as Deep Sleep 1 except that the sleep timer is inactive to save power. In this mode the sleep timer cannot wake up the EM341.
- Deep Sleep 0 (also known as Emulated Deep Sleep): The chip emulates a true deep sleep without powering down the core domain. Instead, the core domain remains powered and all peripherals except the system debug components (ITM, DWT, FPB, NVIC) are held in reset. The purpose of this sleep state is to allow EM341 software to perform a deep sleep cycle while maintaining debug configuration such as breakpoints. CSYSPWRUPREQ, CDBGPWRUPREQ, and the corresponding CSYSPWRUPACK and CDBGPWRUPACK are bits in the debug port's CTRL/STAT register in the SWJ. For further information on these bits and the operation of the SWJ-DP please refer to the ARM Debug Interface v5 Architecture Specification (ARM IHI 0031A).

For further power savings when not in deep sleep, the ADC, Timer 1, Timer 2, Serial Controller1 and Serial Controller 2 peripherals can be individually disabled through the PERIPHERAL\_DISABLE register. Disabling a peripheral saves power by stopping the clock feeding that peripheral. A peripheral should only be disabled through the PERIPHERAL\_DISABLE register when the peripheral is idle and disabled through the peripheral's own configuration registers, otherwise undefined behavior may occur. When a peripheral is disabled through the PERIPHERAL\_DISABLE register, all registers associated with that peripheral ignore all subsequent writes, and subsequent reads return the value seen in the register at the moment the peripheral is disabled.

### 6.5.1. Wake Sources

When in deep sleep the EM341 can be returned to the running state in a number of ways, and the wake sources are split depending on deep sleep 1 or deep sleep 2.

The following wake sources are available in both deep sleep 1 and 2.

- Wake on GPIO activity: Wake due to change of state on any GPIO.
- Wake on serial controller 1: Wake due to a change of state on GPIO Pin PB2.
- Wake on serial controller 2: Wake due to a change of state on GPIO Pin PA2.
- Wake on IRQD: Wake due to a change of state on IRQD. Since IRQD can be configured to point to any GPIO, this wake source is another means of waking on any GPIO activity.
- Wake on setting of CDBGPWRUPREQ: Wake due to setting the CDBGPWRUPREQ bit in the debug port in the SWJ.
- Wake on setting of CSYSPWRUPREQ: Wake due to setting the CSYSPWRUPREQ bit in the debug port in the SWJ.

The following sources are only available in deep sleep 1 since the sleep timer is not active in deep sleep 2.

- Wake on sleep timer compare A.
- Wake on sleep timer compare B.
- Wake on sleep timer wrap.

The following source is only available in deep sleep 0 since the SWJ is required to write a memory mapped register to set this wake source and the SWJ only has access to some registers in deep sleep 0.

- Wake on write to the WAKE\_CORE register bit.

The Wakeup Recording module monitors all possible wakeup sources. More than one wakeup source may be recorded because events are continually being recorded (not just in deep-sleep) and another event may happen between the first wake event and when the EM341 wakes up.

## 6.5.2. Basic Sleep Modes

The power management state diagram in Figure 6.3 shows the basic operation of the power management controller.

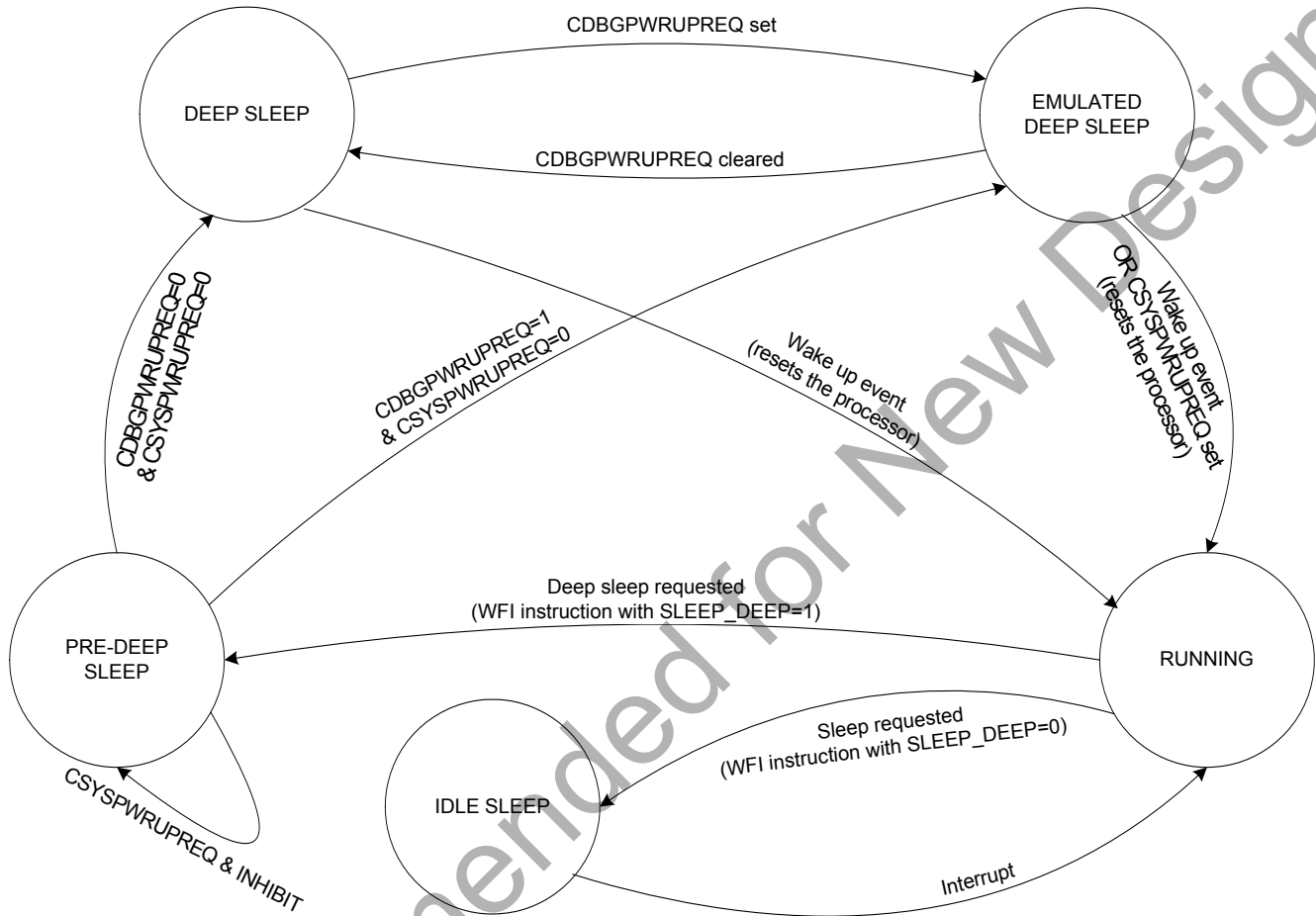

**Figure 6.3. Power Management State Diagram**

In normal operation an application may request one of two low power modes through program execution:

- Idle Sleep is achieved by executing a WFI instruction while the SLEEPDEEP bit in the Cortex System Control register (SCS\_SCR) is clear. This puts the CPU into an idle state where execution is suspended until an interrupt occurs. This is indicated by the state at the bottom of the diagram. Power is maintained to the core logic of the EM341 during the Idle Sleeping state.
- Deep sleep is achieved by executing a WFI instruction with the SLEEPDEEP bit in SCS\_SCR set. This triggers the state transitions around the main loop of the diagram, resulting in powering down the EM341's core logic, and leaving only the always-on domain powered. Wake up is triggered when one of the pre-determined events occurs.

If a deep sleep is requested the EM341 first enters a pre-deep sleep state. This state prevents any section of the chip from being powered off or reset until the SWJ goes idle (by clearing CSYSPWRUPREQ). This pre-deep sleep state ensures debug operations are not interrupted.

In the deep sleep state the EM341 waits for a wake up event which will return it to the running state. In powering up the core logic the ARM® Cortex™-M3 is put through a reset cycle and Ember software restores the stack and application state to the point where deep sleep was invoked.

### 6.5.3. Further Options for Deep Sleep

By default the low-frequency internal RC oscillator (OSCRC) is running during deep sleep (known as deep sleep 1).

To conserve power, OSCRC can be turned off during deep sleep. This mode is known as deep sleep 2. Since the OSCRC is disabled, the sleep timer and watchdog timer do not function and cannot wake the chip unless the low-frequency 32.768 kHz crystal oscillator is used. Non-timer based wake sources continue to function. Once a wake event does occur, OSCRC is restarted and comes back up.

### 6.5.4. Use of Debugger with Sleep Modes

The debugger communicates with the EM341 using the SWJ.

When the debugger is logically connected, the CDBGPWRUPREQ bit in the debug port in the SWJ is set, and the EM341 will only enter deep sleep 0 (the Emulated Deep Sleep state). The CDBGPWRUPREQ bit indicates that a debug tool is logically connected to the chip and therefore debug state may be in the system debug components. To maintain the debug state in the system debug components only deep sleep 0 may be used, since deep sleep 0 will not cause a power cycle or reset of the core domain. The CSYSPWRUPREQ bit in the debug port in the SWJ indicates that a debugger wants to access memory actively in the EM341. Therefore, whenever the CSYSPWRUPREQ bit is set while the EM341 is awake, the EM341 cannot enter deep sleep until this bit is cleared. This ensures the EM341 does not disrupt debug communication into memory.

Clearing both CSYSPWRUPREQ and CDBGPWRUPREQ allows the EM341 to achieve a true deep sleep state (deep sleep 1 or 2). Both of these signals also operate as wake sources, so that when a debugger logically connects to the EM341 and begins accessing the chip, the EM341 automatically comes out of deep sleep. When the debugger initiates access while the EM341 is in deep sleep, the SWJ intelligently holds off the debugger for a brief period of time until the EM341 is properly powered and ready.

**Note:** The SWJ-DP signals CSYSPWRUPREQ and CDBGPWRUPREQ are only reset by a power-on-reset or a debugger. Physically connecting or disconnecting a debugger from the chip will not alter the state of these signals. A debugger must logically communicate with the SWJ-DP to set or clear these two signals.

For more information regarding the SWJ and the interaction of debuggers with deep sleep, contact customer support for Application Notes and ARM® CoreSight™ documentation.

# EM341

## 6.5.5. Registers

**Register 6.1. PERIPHERAL\_DISABLE**

<b>Bit</b>	<b>31</b>	<b>30</b>	<b>29</b>	<b>28</b>	<b>27</b>	<b>26</b>	<b>25</b>	<b>24</b>
<b>Name</b>	0	0	0	0	0	0	0	0
<b>Bit</b>	<b>23</b>	<b>22</b>	<b>21</b>	<b>20</b>	<b>19</b>	<b>18</b>	<b>17</b>	<b>16</b>
<b>Name</b>	0	0	0	0	0	0	0	0
<b>Bit</b>	<b>15</b>	<b>14</b>	<b>13</b>	<b>12</b>	<b>11</b>	<b>10</b>	<b>9</b>	<b>8</b>
<b>Name</b>	0	0	0	0	0	0	0	0
<b>Bit</b>	<b>7</b>	<b>6</b>	<b>5</b>	<b>4</b>	<b>3</b>	<b>2</b>	<b>1</b>	<b>0</b>
<b>Name</b>	0	0	PERIDIS_RSVD	PERIDIS_ADC	PERIDIS_TIM2	PERIDIS_TIM1	PERIDIS_SC1	PERIDIS_SC2

Address: 0x40004038 Reset: 0x0

Bitname	Bitfield	Access	Description
PERIDIS_RSVD	[5]	RW	Reserved: This bit can change during normal operation. When writing to PERIPHERAL_DISABLE, the value of this bit must be preserved.
PERIDIS_ADC	[4]	RW	Disable the clock to the ADC peripheral.
PERIDIS_TIM2	[3]	RW	Disable the clock to the TIM2 peripheral.
PERIDIS_TIM1	[2]	RW	Disable the clock to the TIM1 peripheral.
PERIDIS_SC1	[1]	RW	Disable the clock to the SC1 peripheral.
PERIDIS_SC2	[0]	RW	Disable the clock to the SC2 peripheral.

## 6.6. Security Accelerator

The EM341 contains a hardware AES encryption engine accessible from the ARM® Cortex™-M3. NIST-based CCM, CCM\*, CBC-MAC, and CTR modes are implemented in hardware. These modes are described in the IEEE 802.15.4-2003 specification, with the exception of CCM\*, which is described in the ZigBee Security Services Specification 1.0.

## 7. GPIO (General Purpose Input/Output)

The EM341 has 24 multipurpose GPIO pins, which may be individually configured as follows:

- General purpose output
- General purpose open-drain output
- Alternate output controlled by a peripheral device
- Alternate open-drain output controlled by a peripheral device
- Analog
- General purpose input
- General purpose input with pull-up or pull-down resistor

The basic structure of a single GPIO is illustrated in GPIO Block Diagram Figure 7.1.

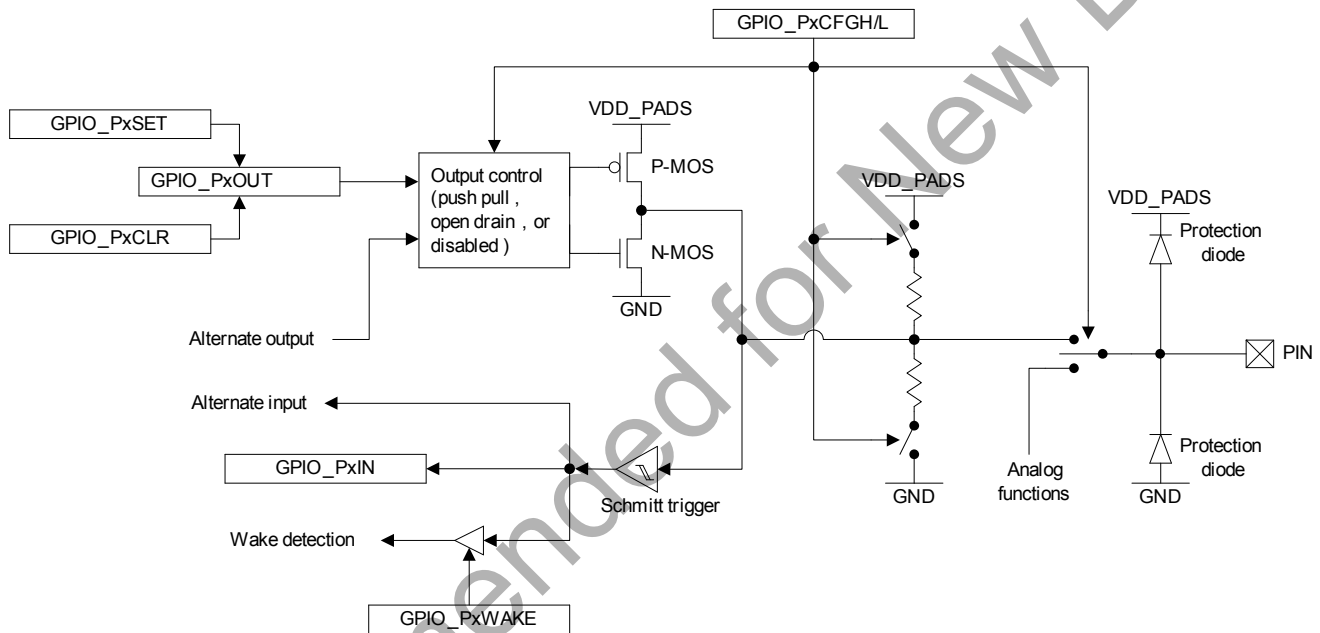

**Figure 7.1. GPIO Block Diagram**

A Schmitt trigger converts the GPIO pin voltage to a digital input value. The digital input signal is then always routed to the **GPIO\_PxIN** register; to the alternate inputs of associated peripheral devices; to wake detection logic if wake detection is enabled; and, for certain pins, to interrupt generation logic. Configuring a pin in analog mode disconnects the digital input from the pin and applies a high logic level to the input of the Schmitt trigger.

Only one device at a time can control a GPIO output. The output is controlled in normal output mode by the **GPIO\_PxOUT** register and in alternate output mode by a peripheral device. When in input mode or analog mode, digital output is disabled.

## 7.1. GPIO Ports

The 24 GPIO pins are grouped into three ports: PA, PB, and PC. Individual GPIOs within a port are numbered 0 to 7 according to their bit positions within the GPIO registers.

**Note:** Because GPIO port registers' functions are identical, the notation Px is used here to refer to PA, PB, or PC. For example, GPIO\_PxIN refers to the registers GPIO\_PAxIN, GPIO\_PBxIN, and GPIO\_PCxIN.

Each of the three GPIO ports has the following registers whose low-order eight bits correspond to the port's eight GPIO pins:

- GPIO\_PxIN (input data register) returns the pin level (unless in analog mode).
- GPIO\_PxOUT (output data register) controls the output level in normal output mode.
- GPIO\_PxCLR (clear output data register) clears bits in GPIO\_PxOUT.
- GPIO\_PxSET (set output data register) sets bits in GPIO\_PxOUT.
- GPIO\_PxWAKE (wake monitor register) specifies the pins that can wake the EM341.

In addition to these registers, each port has a pair of configuration registers, GPIO\_PxCFGL and GPIO\_PxCFGH. These registers specify the basic operating mode for the port's pins. GPIO\_PxCFGL configures the pins Px[3:0] and GPIO\_PxCFGH configures the pins Px[7:4]. For brevity, the notation GPIO\_PxCFGL/H refers to the pair of configuration registers.

Five GPIO pins (PA6, PA7, PB6, PB7 and PC0) can sink and source higher current than standard GPIO outputs. Refer to Table 2.5 Digital I/O Specifications in "2. Electrical Specifications" on page 7 for more information.

## 7.2. Configuration

Each pin has a 4-bit configuration value in the GPIO\_PxCFGL/H register. The various GPIO modes and their 4-bit configuration values are shown in Table 7.1.

**Table 7.1. GPIO Configuration Modes**

GPIO Mode	GPIO_PxCFGL/H	Description
Analog	0x0	Analog input or output. When in analog mode, the digital input (GPIO_PxIN) always reads 1.
Input (floating)	0x4	Digital input without an internal pull up or pull down. Output is disabled.
Input (pull-up or pull-down)	0x8	Digital input with an internal pull up or pull down. A set bit in GPIO_PxOUT selects pull up and a cleared bit selects pull down. Output is disabled.
Output (push-pull)	0x1	Push-pull output. GPIO_PxOUT controls the output.
Output (open-drain)	0x5	Open-drain output. GPIO_PxOUT controls the output. If a pull up is required, it must be external.
Alternate Output (push-pull)	0x9	Push-pull output. An onboard peripheral controls the output.
Alternate Output (open-drain)	0xD	Open-drain output. An onboard peripheral controls the output. If a pull up is required, it must be external.

If a GPIO has two peripherals that can be the source of alternate output mode data, then other registers in addition to GPIO\_PxCFGL/H determine which peripheral controls the output.

Several GPIOs share an alternate output with Timer 2 and the Serial Controllers. Bits in Timer 2's TIM2\_OR register control routing Timer 2 outputs to different GPIOs. Bits in Timer 2's TIM2\_CCER register enable Timer 2 outputs. When Timer 2 outputs are enabled they override Serial Controller outputs. Table 7.2 indicates the GPIO mapping for Timer 2 outputs depending on the bits in the register TIM2\_OR. Refer to "9. General Purpose Timers (TIM1 and TIM2)" on page 113 for complete information on timer configuration.



Table 7.2. Timer 2 Output Configuration Controls

Timer 2 Output	Option Register Bit	GPIO Mapping Selected by TIM2_OR Bit	
		0	1
TIM2C1	TIM2_OR[4]	PA0	PB1
TIM2C2	TIM2_OR[5]	PA3	PB2
TIM2C3	TIM2_OR[6]	PA1	PB3
TIM2C4	TIM2_OR[7]	PA2	PB4

For outputs assigned to the serial controllers, the serial interface mode registers (SCx\_MODE) determine how the GPIO pins are used.

The alternate outputs of PA4 and PA5 can either provide packet trace data (PTI\_EN and PTI\_DATA) or synchronous CPU trace data (TRACEDATA2 and TRACEDATA3). The selection of packet trace or CPU trace is made through the Ember software.

If a GPIO does not have an associated peripheral in alternate output mode, its output is set to 0.

### 7.3. Forced Functions

For some GPIOs, the GPIO\_PxCFGH/L configuration will be overridden. These functions are forced when the EM341 is reset and remain forced until software overrides the forced functions. Table 7.3 shows the GPIOs that have different functions forced on them regardless of the GPIO\_PxCFGH/L registers.

Table 7.3. GPIO Forced Functions

GPIO	Forced Mode	Forced Signal
PA7	Open-drain output	REG_EN
PC0	Input with pull up	JRST
PC2	Push-pull output	JTDO
PC3	Input with pull up	JDTI
PC4*	Input with pull up	JTMS
PC4*	Bidirectional (push-pull output or floating input) controlled by debugger interface	SWDIO

**\*Note:** The choice of PC4's forced signal is controlled by an external debug tool. JTMS is forced when the SWJ is in JTAG mode, and SWDIO is forced when the SWJ is in Serial Wire mode.

PA7 is forced to be the regulator enable signal, REG\_EN. If an external regulator is used and controlled through REG\_EN, PA7's forced functionality must not be overridden. If an external regulator is not used, REG\_EN may be disabled and PA7 may be reclaimed as a normal GPIO. Disabling REG\_EN is done by clearing the bit GPIO\_EXTREGEN in the GPIO\_DBGCFG register.

PC0, PC2, PC3, and PC4 are forced to be the Serial Wire and JTAG (SWJ) Interface. When the EM341 resets, these four GPIOs are forced to operate in JTAG mode. Switching the debug interface between JTAG mode and Serial Wire mode can only be accomplished by the external debug tool and cannot be affected by software executing on the EM341. Due to the fact that Serial Wire mode can only be invoked by an external debug tool and JTAG mode is forced when the EM341 resets, a designer must treat all four debug GPIOs as working in unison even though the Serial Wire interface only uses one of the GPIO, PC4.

**Note:** An application must disable all debug SWJ debug functionality to reclaim any of the four GPIOs: PC0, PC2, PC3, and PC4. Disabling SWJ debug functionality prevents external debug tools from operating, including flash programming and high-level debug tools.

Disabling the SWJ debugger interface is accomplished by setting the GPIO\_DEBUGDIS bit in the GPIO\_DBGCFG register. When this bit is set, all debugger-related pins (PC0, PC2, PC3, PC4) behave as standard GPIOs. If the SWJ debugger interface is already active, the bit GPIO\_DEBUGDIS cannot be set. When GPIO\_DEBUGDIS is set, the SWJ debugger interface can be reclaimed by activating the SWJ while the EM341 is held in reset. If the SWJ debugger interface is forced active in this manner, the bit GPIO\_FORCEDBG is set in the GPIO\_DBGSTAT register. The SWJ debugger interface is defined as active when the CDBGPWRUPREQ signal, a bit in the debug port's CTRL/STAT register in the SWJ, is set high by an external debug tool.

## 7.4. Reset

A full chip reset is one due to power on (low or high voltage), the nRESET pin, the watchdog, or the SYSRESETREQ bit. A full chip reset affects the GPIO configuration as follows:

- The GPIO\_PxCFGH/L configurations of all pins are configured as floating inputs.
- The GPIO\_EXTREGEN bit is set in the GPIO\_DBGCFG register, which overrides the normal configuration for PA7.
- The GPIO\_DEBUGDIS bit in the GPIO\_DBGCFG register is cleared, allowing Serial Wire/JTAG access to override the normal configuration of PC0, PC2, PC3, and PC4.

## 7.5. Boot Configuration

nBOOTMODE is a special alternate function of PA5 that is active only during a pin reset (nRESET) or a power-on-reset of the always-powered domain (POR HV). If nBOOTMODE is asserted (pulled or driven low) when coming out of reset, the processor starts executing an embedded serial-link-only monitor instead of its normal program.

While in reset and during the subsequent power-on-reset startup delay (512 OSCHF clocks), PA5 is automatically configured as an input with a pull-up resistor. At the end of this time, the EM341 samples nBOOTMODE: a high level selects normal boot mode, and a low level selects the embedded monitor. Figure 7.2 shows the timing parameters for invoking monitor mode from a pin (nRESET) reset. Because OSCHF is running uncalibrated during the reset sequence, the time for 512 OSCHF clocks may vary as indicated.

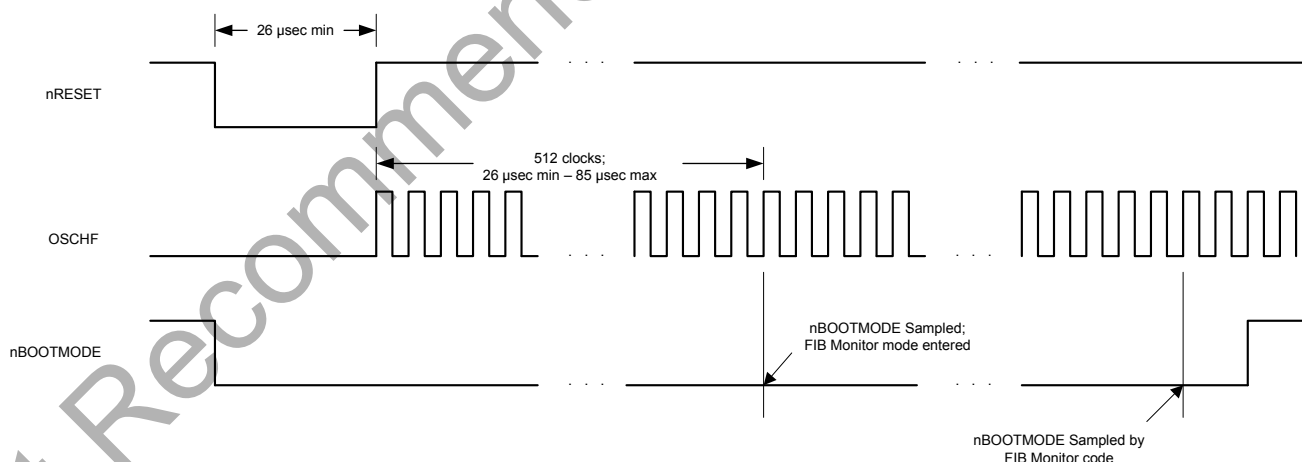

**Figure 7.2. nBOOTMODE and nRESET Timing**

Timing for a power-on-reset is similar except that OSCHF does not begin oscillating until up to 70 µsec after both core and HV supplies are valid. Combined with the maximum 250 µsec allowed for HV to ramp from 0.5 V to 1.7 V, an additional 320 µsec may be added to the 512 OSCHF clocks until nBOOTMODE is sampled.

If the monitor mode is selected (nBOOTMODE is low after 512 clocks), the FIB monitor software begins execution. In order to filter out inadvertent jumps into the monitor, the FIB monitor re-samples the nBOOTMODE signal after a 3 ms delay. If the signal is still low, then the device stays in monitor mode. If the signal is high, then monitor mode

is exited and the normal program begins execution. In summary, the nBOOTMODE signal must be held low for 4 ms in order to properly invoke the FIB monitor.

After nBOOTMODE has been sampled, PA5 is configured as a floating input like the other GPIO configurations. The GPIO\_BOOTMODE bit in the GPIO\_DBGSTAT register captures the state of nBOOTMODE so that software may act on this signal if required.

**Note:** To avoid inadvertently asserting nBOOTMODE, PA5's capacitive load may not exceed 250 pF.

## 7.6. GPIO Modes

### 7.6.1. Analog Mode

Analog mode enables analog functions, and disconnects a pin from the digital input and output logic. Only the following GPIO pins have analog functions:

- PA4, PA5, PB5, PB6, PB7, and PC1 can be analog inputs to the ADC.
- PB0 can output the internal analog voltage reference from the ADC.
- PC6 and PC7 can connect to an optional 32.768 kHz crystal.

**Note:** When an external timing source is required, a 32.768 kHz crystal is commonly connected to PC6 and PC7. Alternatively, when PC7 is configured as a digital input, PC7 can accept a digital external clock input.

When configured in analog mode:

- The output drivers are disabled.
- The internal pull-up and pull-down resistors are disabled.
- The Schmitt trigger input is connected to a high logic level.
- Reading GPIO\_PxIN returns a constant 1.

### 7.6.2. Input Mode

Input mode is used both for general purpose input and for on-chip peripheral inputs. Input floating mode disables the internal pull-up and pull-down resistors, leaving the pin in a high-impedance state. Input pull-up or pull-down mode enables either an internal pull-up or pull-down resistor based on the GPIO\_PxOUT register. Setting a bit to 0 in GPIO\_PxOUT enables the pull-down and setting a bit to 1 enables the pull up.

When configured in input mode:

- The output drivers are disabled.
- An internal pull-up or pull-down resistor may be activated depending on GPIO\_PxCFGL and GPIO\_PxOUT.
- The Schmitt trigger input is connected to the pin.
- Reading GPIO\_PxIN returns the input at the pin.
- The input is also available to on-chip peripherals.

### 7.6.3. Output Mode

Output mode provides a general purpose output under direct software control. Regardless of whether an output is configured as push-pull or open-drain, the GPIO's bit in the GPIO\_PxOUT register controls the output. The GPIO\_PxSET and GPIO\_PxCLR registers can atomically set and clear bits within GPIO\_PxOUT register. These set and clear registers simplify software using the output port because they eliminate the need to disable interrupts to perform an atomic read-modify-write operation of GPIO\_PxOUT.

When configured in output mode:

- The output drivers are enabled and are controlled by the value written to GPIO\_PxOUT:
  - In open-drain mode: 0 activates the N-MOS current sink; 1 tri-states the pin.
  - In push-pull mode: 0 activates the N-MOS current sink; 1 activates the P-MOS current source.
- The internal pull-up and pull-down resistors are disabled.
- The Schmitt trigger input is connected to the pin.
- Reading GPIO\_PxIN returns the input at the pin.

**Note:** Reading GPIO\_PxOUT returns the last value written to the register.

Depending on configuration and usage, GPIO\_PxOUT and GPIO\_PxIN may not have the same value.

#### 7.6.4. Alternate Output Mode

In this mode, the output is controlled by an on-chip peripheral instead of GPIO\_PxOUT and may be configured as either push-pull or open-drain. Most peripherals require a particular output type – TWI requires an open-drain driver, for example – but since using a peripheral does not by itself configure a pin, the GPIO\_PxCFGL/L registers must be configured properly for a peripheral's particular needs. As described in "7.2. Configuration" on page 49, when more than one peripheral can be the source of output data, registers in addition to GPIO\_PxCFGL/L determine which to use.

When configured in alternate output mode:

- The output drivers are enabled and are controlled by the output of an on-chip peripheral:
  - In open-drain mode: 0 activates the N-MOS current sink; 1 tri-states the pin.
  - In push-pull mode: 0 activates the N-MOS current sink; 1 activates the P-MOS current source.
- The internal pull-up and pull-down resistors are disabled.
- The Schmitt trigger input is connected to the pin.

**Note:** Reading GPIO\_PxIN returns the input to the pin.

Depending on configuration and usage, GPIO\_PxOUT and GPIO\_PxIN may not have the same value.

#### 7.7. Wake Monitoring

The GPIO\_PxWAKE registers specify which GPIOs are monitored to wake the processor. If a GPIO's wake enable bit is set in GPIO\_PxWAKE, then a change in the logic value of that GPIO causes the EM341 to wake from deep sleep. The logic values of all GPIOs are captured by hardware upon entering sleep. If any GPIO's logic value changes while in sleep and that GPIO's GPIO\_PxWAKE bit is set, then the EM341 wakes from deep sleep. (There is no mechanism for selecting a specific rising-edge, falling-edge, or level on a GPIO: any change in logic value triggers a wake event.) Hardware records the fact that GPIO activity caused a wake event, but not which specific GPIO was responsible. Instead, the Ember software reads the state of the GPIOs on waking to determine this.

The register GPIO\_WAKEFILT contains bits to enable digital filtering of the external wakeup event sources: the GPIO pins, SC1 activity, SC2 activity, and IRQD. The digital filter operates by taking samples based on the (nominal) 10 kHz RC oscillator. If three samples in a row all have the same logic value, and this sampled logic value is different from the logic value seen upon entering sleep, the filter outputs a wakeup event.

In order to use GPIO pins to wake the EM341 from deep sleep, the GPIO\_WAKE bit in the WAKE\_SEL register must be set. Waking up from GPIO activity does not work with pins configured for analog mode since the digital logic input is always set to 1 when in analog mode. Refer to "6. System Modules" on page 33 for information on the EM341's power management and sleep modes.

#### 7.8. External Interrupts

The EM341 can use up to four external interrupt sources (IRQA, IRQB, IRQC, and IRQD), each with its own top-level NVIC interrupt vector. Since these external interrupt sources connect to the standard GPIO input path, an external interrupt pin may simultaneously be used by a peripheral device or even configured as an output. Analog mode is the only GPIO configuration that is not compatible with using a pin as an external interrupt.

External interrupts have individual triggering and filtering options selected using the registers GPIO\_INTCFGA, GPIO\_INTCFGB, GPIO\_INTCFGC, and GPIO\_INTCFGD. The bit field GPIO\_INTMOD of the GPIO\_INTCFGx register enables IRQx's second-level interrupt and selects the triggering mode: 0 is disabled; 1 for rising edge; 2 for falling edge; 3 for both edges; 4 for active high level; 5 for active low level. The minimum width needed to latch an unfiltered external interrupt in both level- and edge-triggered mode is 80 ns. With the digital filter enabled (the GPIO\_INTFILT bit in the GPIO\_INTCFGx register is set), the minimum width needed is 450 ns.

The register INT\_GPIOFLAG is the second-level interrupt flag register that indicates pending external interrupts. Writing 1 to a bit in the INT\_GPIOFLAG register clears the flag while writing 0 has no effect. If the interrupt is level-triggered, the flag bit is set again immediately after being cleared if its input is still in the active state.

Two of the four external interrupts, IRQA and IRQB, have fixed pin assignments. The other two external interrupts, IRQC and IRQD, can use any GPIO pin. The GPIO\_IRQCSEL and GPIO\_IRQDSEL registers specify the GPIO pins assigned to IRQC and IRQD, respectively. Table 7.4 shows how the GPIO\_IRQCSEL and GPIO\_IRQDSEL register values select the GPIO pin used for the external interrupt.

Table 7.4. IRQC/D GPIO Selection

GPIO_IRQxSEL	GPIO	GPIO_IRQxSEL	GPIO	GPIO_IRQxSEL	GPIO
0	PA0	8	PB0	16	PC0
1	PA1	9	PB1	17	PC1
2	PA2	10	PB2	18	PC2
3	PA3	11	PB3	19	PC3
4	PA4	12	PB4	20	PC4
5	PA5	13	PB5	21	PC5
6	PA6	14	PB6	22	PC6
7	PA7	15	PB7	23	PC7

In some cases, it may be useful to assign IRQC or IRQD to an input also in use by a peripheral, for example to generate an interrupt from the slave select signal (nSSEL) in an SPI slave mode interface.

Refer to "9. Interrupt System" on page 100 for further information regarding the EM341 interrupt system.

## 7.9. Debug Control and Status

Two GPIO registers are largely concerned with debugger functions. GPIO\_DBGCFG can disable debugger operation, but has other miscellaneous control bits as well. GPIO\_DBGSTAT, a read-only register, returns status related to debugger activity (GPIO\_FORCEDBG and GPIO\_SWEN), as well a flag (GPIO\_BOOTMODE) indicating whether nBOOTMODE was asserted at the last power-on or nRESET-based reset.

## 7.10. GPIO Signal Assignment Summary

The GPIO signal assignments are shown in Table 7.5.

**Table 7.5. GPIO Signal Assignments**

GPIO	Analog	Alternate Output	Input	Output Current Drive
PA0		TIM2C1 <sup>1</sup> , SC2MOSI	TIM2C1 <sup>1</sup> , SC2MOSI	Standard
PA1		TIM2C3 <sup>1</sup> , SC2MISO, SC2SDA	TIM2C3 <sup>1</sup> , SC2MISO, SC2SDA	Standard
PA2		TIM2C4 <sup>1</sup> , SC2SCLK, SC2SCL	TIM2C4 <sup>1</sup> , SC2SCLK	Standard
PA3		TIM2C2 <sup>1</sup> , TRACECLK	TIM2C2 <sup>1</sup> , SC2nSSEL	Standard
PA4	ADC4	PTI_EN, TRACEDATA2		Standard
PA5	ADC5	PTI_DATA, TRACEDATA3	nBOOTMODE <sup>2</sup>	Standard
PA6		TIM1C3	TIM1C3	High
PA7		TIM1C4, REG_EN <sup>3</sup>	TIM1C4	High
PB0	VREF	TRACECLK	TIM1CLK, TIM2MSK, IRQA	Standard
PB1		TIM2C1 <sup>4</sup> , SC1TXD, SC1MOSI, SC1MISO, SC1SDA	TIM2C1 <sup>4</sup> , SC1SDA	Standard
PB2		TIM2C2 <sup>4</sup> , SC1SCLK	TIM2C2 <sup>4</sup> , SC1MISO, SC1MOSI, SC1SCL, SC1RXD	Standard
PB3		TIM2C3 <sup>4</sup> , SC1SCLK	TIM2C3 <sup>4</sup> , SC1SCLK, SC1nCTS	Standard
PB4		TIM2C4 <sup>4</sup> , SC1nRTS	TIM2C4 <sup>4</sup> , SC1nSSEL	Standard
PB5	ADC0		TIM2CLK, TIM1MSK	Standard
PB6	ADC1	TIM1C1	TIM1C1, IRQB	High
PB7	ADC2	TIM1C2	TIM1C2	High
PC0		TRACEDATA1	JRST <sup>5</sup>	High
PC1	ADC3	TRACEDATA0, SWO		Standard
PC2		JTDO <sup>6</sup> , SWO		Standard
PC3			JTDI <sup>5</sup>	Standard
PC4		SWDIO <sup>7</sup>	SWDIO <sup>7</sup> , JTMS <sup>7</sup>	Standard
PC5		TX_ACTIVE		Standard
PC6	OSC32B	nTX_ACTIVE		Standard
PC7	OSC32A		OSC32_EXT	Standard

**Notes:**

1. Default signal assignment (not remapped).
2. Overrides during reset as an input with pull up.
3. Overrides after reset as an open-drain output.
4. Alternate signal assignment (remapped).
5. Overrides in JTAG mode as a input with pull up.
6. Overrides in JTAG mode as a push-pull output.
7. Overrides in Serial Wire mode as either a push-pull output, or a floating input, controlled by the debugger.

# EM341

## 7.11. Registers

**Note:** Substitute “A”, “B”, or “C” for “x” in the following detailed descriptions.

### Register 7.1. GPIO\_PxCFGL

GPIO\_PACFGL: Port A Configuration Register (Low)

GPIO\_PBCFGL: Port B Configuration Register (Low)

GPIO\_PCCFGL: Port C Configuration Register (Low)

<b>Bit</b>	<b>31</b>	<b>30</b>	<b>29</b>	<b>28</b>	<b>27</b>	<b>26</b>	<b>25</b>	<b>24</b>
<b>Name</b>	0	0	0	0	0	0	0	0
<b>Bit</b>	<b>23</b>	<b>22</b>	<b>21</b>	<b>20</b>	<b>19</b>	<b>18</b>	<b>17</b>	<b>16</b>
<b>Name</b>	0	0	0	0	0	0	0	0
<b>Bit</b>	<b>15</b>	<b>14</b>	<b>13</b>	<b>12</b>	<b>11</b>	<b>10</b>	<b>9</b>	<b>8</b>
<b>Name</b>	Px3_CFG				Px2_CFG			
<b>Bit</b>	<b>7</b>	<b>6</b>	<b>5</b>	<b>4</b>	<b>3</b>	<b>2</b>	<b>1</b>	<b>0</b>
<b>Name</b>	Px1_CFG				Px0_CFG			

GPIO\_PACFGL: Address: 0x4000B000 Reset: 0x4444

GPIO\_PBCFGL: Address: 0x4000B400 Reset: 0x4444

GPIO\_PCCFGL: Address: 0x4000B800 Reset: 0x4444

Bitname	Bitfield	Access	Description
Px3_CFG	[15:12]	RW	GPIO configuration control. 0x0: Analog, input or output (GPIO_PxIN always reads 1). 0x1: Output, push-pull (GPIO_PxOUT controls the output). 0x4: Input, floating. 0x5: Output, open-drain (GPIO_PxOUT controls the output). 0x8: Input, pulled up or down (selected by GPIO_PxOUT: 0 = pull-down, 1 = pull-up). 0x9: Alternate output, push-pull (peripheral controls the output). 0xD: Alternate output, open-drain (peripheral controls the output).
Px2_CFG	[11:8]	RW	GPIO configuration control: see Px3_CFG above.
Px1_CFG	[7:4]	RW	GPIO configuration control: see Px3_CFG above.
Px0_CFG	[3:0]	RW	GPIO configuration control: see Px3_CFG above.

**Register 7.2. GPIO\_PxCFGH**

GPIO\_PACFGH: Port A Configuration Register (High)

GPIO\_PBCFGH: Port B Configuration Register (High)

GPIO\_PCCFGH: Port C Configuration Register (High)

<b>Bit</b>	<b>31</b>	<b>30</b>	<b>29</b>	<b>28</b>	<b>27</b>	<b>26</b>	<b>25</b>	<b>24</b>
<b>Name</b>	0	0	0	0	0	0	0	0
<b>Bit</b>	<b>23</b>	<b>22</b>	<b>21</b>	<b>20</b>	<b>19</b>	<b>18</b>	<b>17</b>	<b>16</b>
<b>Name</b>	0	0	0	0	0	0	0	0
<b>Bit</b>	<b>15</b>	<b>14</b>	<b>13</b>	<b>12</b>	<b>11</b>	<b>10</b>	<b>9</b>	<b>8</b>
<b>Name</b>	Px7_CFG				Px6_CFG			
<b>Bit</b>	<b>7</b>	<b>6</b>	<b>5</b>	<b>4</b>	<b>3</b>	<b>2</b>	<b>1</b>	<b>0</b>
<b>Name</b>	Px5_CFG				Px4_CFG			

GPIO\_PACFGH: Address: 0x4000B004 Reset: 0x4444

GPIO\_PBCFGH: Address: 0x4000B404 Reset: 0x4444

GPIO\_PCCFGH: Address: 0x4000B804 Reset: 0x4444

<b>Bitname</b>	<b>Bitfield</b>	<b>Access</b>	<b>Description</b>
Px7_CFG	[15:12]	RW	GPIO configuration control. 0x0: Analog, input or output (GPIO_PxIN always reads 1). 0x1: Output, push-pull (GPIO_PxOUT controls the output). 0x4: Input, floating. 0x5: Output, open-drain (GPIO_PxOUT controls the output). 0x8: Input, pulled up or down (selected by GPIO_PxOUT: 0 = pull-down, 1 = pull-up). 0x9: Alternate output, push-pull (peripheral controls the output). 0xD: Alternate output, open-drain (peripheral controls the output).
Px6_CFG	[11:8]	RW	GPIO configuration control: see Px7_CFG above.
Px5_CFG	[7:4]	RW	GPIO configuration control: see Px7_CFG above.
Px4_CFG	[3:0]	RW	GPIO configuration control: see Px7_CFG above.



# EM341

## Register 7.3. GPIO\_PxIN

GPIO\_PAIN: Port A Input Data Register

GPIO\_PBIN: Port B Input Data Register

GPIO\_PCIN: Port C Input Data Register

<b>Bit</b>	<b>31</b>	<b>30</b>	<b>29</b>	<b>28</b>	<b>27</b>	<b>26</b>	<b>25</b>	<b>24</b>
<b>Name</b>	0	0	0	0	0	0	0	0
<b>Bit</b>	<b>23</b>	<b>22</b>	<b>21</b>	<b>20</b>	<b>19</b>	<b>18</b>	<b>17</b>	<b>16</b>
<b>Name</b>	0	0	0	0	0	0	0	0
<b>Bit</b>	<b>15</b>	<b>14</b>	<b>13</b>	<b>12</b>	<b>11</b>	<b>10</b>	<b>9</b>	<b>8</b>
<b>Name</b>	0	0	0	0	0	0	0	0
<b>Bit</b>	<b>7</b>	<b>6</b>	<b>5</b>	<b>4</b>	<b>3</b>	<b>2</b>	<b>1</b>	<b>0</b>
<b>Name</b>	Px7	Px6	Px5	Px4	Px3	Px2	Px1	Px0

GPIO\_PAIN: Address: 0x4000B008 Reset: 0x0

GPIO\_PBIN: Address: 0x4000B408 Reset: 0x0

GPIO\_PCIN: Address: 0x4000B808 Reset: 0x0

Bitname	Bitfield	Access	Description
Px7	[7]	RW	Input level at pin Px7.
Px6	[6]	RW	Input level at pin Px6.
Px5	[5]	RW	Input level at pin Px5.
Px4	[4]	RW	Input level at pin Px4.
Px3	[3]	RW	Input level at pin Px3.
Px2	[2]	RW	Input level at pin Px2.
Px1	[1]	RW	Input level at pin Px1.
Px0	[0]	RW	Input level at pin Px0.

**Register 7.4. GPIO\_PxOUT**

GPIO\_PAOUT: Port A Output Data Register

GPIO\_PBOUT: Port B Output Data Register

GPIO\_PCOUT: Port C Output Data Register

<b>Bit</b>	<b>31</b>	<b>30</b>	<b>29</b>	<b>28</b>	<b>27</b>	<b>26</b>	<b>25</b>	<b>24</b>
<b>Name</b>	0	0	0	0	0	0	0	0
<b>Bit</b>	<b>23</b>	<b>22</b>	<b>21</b>	<b>20</b>	<b>19</b>	<b>18</b>	<b>17</b>	<b>16</b>
<b>Name</b>	0	0	0	0	0	0	0	0
<b>Bit</b>	<b>15</b>	<b>14</b>	<b>13</b>	<b>12</b>	<b>11</b>	<b>10</b>	<b>9</b>	<b>8</b>
<b>Name</b>	0	0	0	0	0	0	0	0
<b>Bit</b>	<b>7</b>	<b>6</b>	<b>5</b>	<b>4</b>	<b>3</b>	<b>2</b>	<b>1</b>	<b>0</b>
<b>Name</b>	Px7	Px6	Px5	Px4	Px3	Px2	Px1	Px0

GPIO\_PAOUT: Address: 0x4000B00C Reset: 0x0

GPIO\_PBOUT: Address: 0x4000B40C Reset: 0x0

GPIO\_PCOUT: Address: 0x4000B80C Reset: 0x0

Bitname	Bitfield	Access	Description
Px7	[7]	RW	Output data for Px7.
Px6	[6]	RW	Output data for Px6.
Px5	[5]	RW	Output data for Px5.
Px4	[4]	RW	Output data for Px4.
Px3	[3]	RW	Output data for Px3.
Px2	[2]	RW	Output data for Px2.
Px1	[1]	RW	Output data for Px1.
Px0	[0]	RW	Output data for Px0.

# EM341

## Register 7.5. GPIO\_PxCLR

GPIO\_PACLR: Port A Output Clear Register

GPIO\_PBCLR: Port B Output Clear Register

GPIO\_PCCLR: Port C Output Clear Register

<b>Bit</b>	<b>31</b>	<b>30</b>	<b>29</b>	<b>28</b>	<b>27</b>	<b>26</b>	<b>25</b>	<b>24</b>
<b>Name</b>	0	0	0	0	0	0	0	0
<b>Bit</b>	<b>23</b>	<b>22</b>	<b>21</b>	<b>20</b>	<b>19</b>	<b>18</b>	<b>17</b>	<b>16</b>
<b>Name</b>	0	0	0	0	0	0	0	0
<b>Bit</b>	<b>15</b>	<b>14</b>	<b>13</b>	<b>12</b>	<b>11</b>	<b>10</b>	<b>9</b>	<b>8</b>
<b>Name</b>	0	0	0	0	0	0	0	0
<b>Bit</b>	<b>7</b>	<b>6</b>	<b>5</b>	<b>4</b>	<b>3</b>	<b>2</b>	<b>1</b>	<b>0</b>
<b>Name</b>	Px7	Px6	Px5	Px4	Px3	Px2	Px1	Px0

GPIO\_PACLR: Address: 0x4000B014 Reset: 0x0

GPIO\_PBCLR: Address: 0x4000B414 Reset: 0x0

GPIO\_PCCLR: Address: 0x4000B814 Reset: 0x0

Bitname	Bitfield	Access	Description
Px7	[7]	W	Write 1 to clear the output data bit for Px7 (writing 0 has no effect).
Px6	[6]	W	Write 1 to clear the output data bit for Px6 (writing 0 has no effect).
Px5	[5]	W	Write 1 to clear the output data bit for Px5 (writing 0 has no effect).
Px4	[4]	W	Write 1 to clear the output data bit for Px4 (writing 0 has no effect).
Px3	[3]	W	Write 1 to clear the output data bit for Px3 (writing 0 has no effect).
Px2	[2]	W	Write 1 to clear the output data bit for Px2 (writing 0 has no effect).
Px1	[1]	W	Write 1 to clear the output data bit for Px1 (writing 0 has no effect).
Px0	[0]	W	Write 1 to clear the output data bit for Px0 (writing 0 has no effect).

**Register 7.6. GPIO\_PxSET**

GPIO\_PASET: Port A Output Set Register

GPIO\_PBSET: Port B Output Set Register

GPIO\_PCSET: Port C Output Set Register

<b>Bit</b>	<b>31</b>	<b>30</b>	<b>29</b>	<b>28</b>	<b>27</b>	<b>26</b>	<b>25</b>	<b>24</b>
<b>Name</b>	0	0	0	0	0	0	0	0
<b>Bit</b>	<b>23</b>	<b>22</b>	<b>21</b>	<b>20</b>	<b>19</b>	<b>18</b>	<b>17</b>	<b>16</b>
<b>Name</b>	0	0	0	0	0	0	0	0
<b>Bit</b>	<b>15</b>	<b>14</b>	<b>13</b>	<b>12</b>	<b>11</b>	<b>10</b>	<b>9</b>	<b>8</b>
<b>Name</b>	GPIO_PXSETRSVD							
<b>Bit</b>	<b>7</b>	<b>6</b>	<b>5</b>	<b>4</b>	<b>3</b>	<b>2</b>	<b>1</b>	<b>0</b>
<b>Name</b>	Px7	Px6	Px5	Px4	Px3	Px2	Px1	Px0

GPIO\_PASET: Address: 0x4000B010 Reset: 0x0

GPIO\_PBSET: Address: 0x4000B410 Reset: 0x0

GPIO\_PCSET: Address: 0x4000B810 Reset: 0x0

Bitname	Bitfield	Access	Description
GPIO_PXSETRSVD	[15:8]	W	Reserved: these bits must be set to 0.
Px7	[7]	W	Write 1 to set the output data bit for Px7 (writing 0 has no effect).
Px6	[6]	W	Write 1 to set the output data bit for Px6 (writing 0 has no effect).
Px5	[5]	W	Write 1 to set the output data bit for Px5 (writing 0 has no effect).
Px4	[4]	W	Write 1 to set the output data bit for Px4 (writing 0 has no effect).
Px3	[3]	W	Write 1 to set the output data bit for Px3 (writing 0 has no effect).
Px2	[2]	W	Write 1 to set the output data bit for Px2 (writing 0 has no effect).
Px1	[1]	W	Write 1 to set the output data bit for Px1 (writing 0 has no effect).
Px0	[0]	W	Write 1 to set the output data bit for Px0 (writing 0 has no effect).

# EM341

## Register 7.7. GPIO\_PxWAKE

GPIO\_PAWAKE: Port A Wakeup Monitor Register

GPIO\_PBWAKE: Port B Wakeup Monitor Register

GPIO\_PCWAKE: Port C Wakeup Monitor Register

Bit	31	30	29	28	27	26	25	24
Name	0	0	0	0	0	0	0	0
Bit	23	22	21	20	19	18	17	16
Name	0	0	0	0	0	0	0	0
Bit	15	14	13	12	11	10	9	8
Name	0	0	0	0	0	0	0	0
Bit	7	6	5	4	3	2	1	0
Name	Px7	Px6	Px5	Px4	Px3	Px2	Px1	Px0

GPIO\_PAWAKE: Address: 0x4000BC08 Reset: 0x0

GPIO\_PBWAKE: Address: 0x4000BC0C Reset: 0x0

GPIO\_PCWAKE: Address: 0x4000BC10 Reset: 0x0

Bitname	Bitfield	Access	Description
Px7	[7]	RW	Write 1 to enable wakeup monitoring of Px7.
Px6	[6]	RW	Write 1 to enable wakeup monitoring of Px6.
Px5	[5]	RW	Write 1 to enable wakeup monitoring of Px5.
Px4	[4]	RW	Write 1 to enable wakeup monitoring of Px4.
Px3	[3]	RW	Write 1 to enable wakeup monitoring of Px3.
Px2	[2]	RW	Write 1 to enable wakeup monitoring of Px2.
Px1	[1]	RW	Write 1 to enable wakeup monitoring of Px1.
Px0	[0]	RW	Write 1 to enable wakeup monitoring of Px0.

**Register 7.8. GPIO\_WAKEFILT: GPIO Wakeup Filtering Register**

<b>Bit</b>	<b>31</b>	<b>30</b>	<b>29</b>	<b>28</b>	<b>27</b>	<b>26</b>	<b>25</b>	<b>24</b>
<b>Name</b>	0	0	0	0	0	0	0	0
<b>Bit</b>	<b>23</b>	<b>22</b>	<b>21</b>	<b>20</b>	<b>19</b>	<b>18</b>	<b>17</b>	<b>16</b>
<b>Name</b>	0	0	0	0	0	0	0	0
<b>Bit</b>	<b>15</b>	<b>14</b>	<b>13</b>	<b>12</b>	<b>11</b>	<b>10</b>	<b>9</b>	<b>8</b>
<b>Name</b>	0	0	0	0	0	0	0	0
<b>Bit</b>	<b>7</b>	<b>6</b>	<b>5</b>	<b>4</b>	<b>3</b>	<b>2</b>	<b>1</b>	<b>0</b>
<b>Name</b>	0	0	0	0	IRQD_WAKE_FILTER	SC2_WAKE_FILTER	SC1_WAKE_FILTER	GPIO_WAKE_FILTER

Address: 0x4000BC1C Reset: 0x0

Bitname	Bitfield	Access	Description
IRQD_WAKE_FILTER	[3]	RW	Enable filter on GPIO wakeup source IRQD.
SC2_WAKE_FILTER	[2]	RW	Enable filter on GPIO wakeup source SC2 (PA2).
SC1_WAKE_FILTER	[1]	RW	Enable filter on GPIO wakeup source SC1 (PB2).
GPIO_WAKE_FILTER	[0]	RW	Enable filter on GPIO wakeup sources enabled by the GPIO_PnWAKE registers.

# EM341

**Note:** Substitute “C” or “D” for “x” in the following detailed description.

## Register 7.9. GPIO\_IRQxSEL

**GPIO\_IRQCSEL:** Interrupt C Select Register

**GPIO\_IRQDSEL:** Interrupt D Select Register

<b>Bit</b>	<b>31</b>	<b>30</b>	<b>29</b>	<b>28</b>	<b>27</b>	<b>26</b>	<b>25</b>	<b>24</b>
<b>Name</b>	0	0	0	0	0	0	0	0
<b>Bit</b>	<b>23</b>	<b>22</b>	<b>21</b>	<b>20</b>	<b>19</b>	<b>18</b>	<b>17</b>	<b>16</b>
<b>Name</b>	0	0	0	0	0	0	0	0
<b>Bit</b>	<b>15</b>	<b>14</b>	<b>13</b>	<b>12</b>	<b>11</b>	<b>10</b>	<b>9</b>	<b>8</b>
<b>Name</b>	0	0	0	0	0	0	0	0
<b>Bit</b>	<b>7</b>	<b>6</b>	<b>5</b>	<b>4</b>	<b>3</b>	<b>2</b>	<b>1</b>	<b>0</b>
<b>Name</b>	0	0	0	SEL_GPIO				

GPIO\_IRQCSEL: Address: 0x4000BC14 Reset: 0xF

GPIO\_IRQDSEL: Address: 0x4000BC18 Reset: 0x10

Bitname	Bitfield	Access	Description
SEL_GPIO	[4:0]	RW	Pin assigned to IRQx. 0x00: PA0 0x01: PA1 0x02: PA2 0x03: PA3 0x04: PA4 0x05: PA5 0x06: PA6 0x07: PA7 0x08: PB0 0x09: PB1 0x0A: PB2 0x0B: PB3 0x0C: PB4 0x0D: PB5 0x0E: PB6 0x0F: PB7 0x10: PC0 0x11: PC1 0x12: PC2 0x13: PC3 0x14: PC4 0x15: PC5 0x16: PC6 0x17: PC7 0x18–0x1F: Reserved

**Note:** Substitute “A”, “B”, “C”, or “D” for “x” in the following detailed description.

### Register 7.10. GPIO\_INTCFGx

**GPIO\_INTCFGx:** GPIO Interrupt A Configuration Register

**GPIO\_INTCFGb:** GPIO Interrupt B Configuration Register

**GPIO\_INTCFGc:** GPIO Interrupt C Configuration Register

**GPIO\_INTCFGd:** GPIO Interrupt D Configuration Register

<b>Bit</b>	<b>31</b>	<b>30</b>	<b>29</b>	<b>28</b>	<b>27</b>	<b>26</b>	<b>25</b>	<b>24</b>
<b>Name</b>	0	0	0	0	0	0	0	0
<b>Bit</b>	<b>23</b>	<b>22</b>	<b>21</b>	<b>20</b>	<b>19</b>	<b>18</b>	<b>17</b>	<b>16</b>
<b>Name</b>	0	0	0	0	0	0	0	0
<b>Bit</b>	<b>15</b>	<b>14</b>	<b>13</b>	<b>12</b>	<b>11</b>	<b>10</b>	<b>9</b>	<b>8</b>
<b>Name</b>	0	0	0	0	0	0	0	GPIO_INTFILT
<b>Bit</b>	<b>7</b>	<b>6</b>	<b>5</b>	<b>4</b>	<b>3</b>	<b>2</b>	<b>1</b>	<b>0</b>
<b>Name</b>	GPIO_INTMOD			0	0	0	0	0

GPIO\_INTCFGa: Address: 0x4000A860 Reset: 0x0

GPIO\_INTCFGb: Address: 0x4000A864 Reset: 0x0

GPIO\_INTCFGc: Address: 0x4000A868 Reset: 0x0

GPIO\_INTCFGd: Address: 0x4000A86C Reset: 0x0

Bitname	Bitfield	Access	Description
GPIO_INTFILT	[8]	RW	Set this bit to enable digital filtering on IRQx.
GPIO_INTMOD	[7:5]	RW	IRQx triggering mode. 0x0: Disabled. 0x1: Rising edge triggered. 0x2: Falling edge triggered. 0x3: Rising and falling edge triggered. 0x4: Active high level triggered. 0x5: Active low level triggered. 0x6, 0x7: Reserved.



# EM341

**Register 7.11. INT\_GPIOFLAG: GPIO Interrupt Flag Register**

<b>Bit</b>	<b>31</b>	<b>30</b>	<b>29</b>	<b>28</b>	<b>27</b>	<b>26</b>	<b>25</b>	<b>24</b>
<b>Name</b>	0	0	0	0	0	0	0	0
<b>Bit</b>	<b>23</b>	<b>22</b>	<b>21</b>	<b>20</b>	<b>19</b>	<b>18</b>	<b>17</b>	<b>16</b>
<b>Name</b>	0	0	0	0	0	0	0	0
<b>Bit</b>	<b>15</b>	<b>14</b>	<b>13</b>	<b>12</b>	<b>11</b>	<b>10</b>	<b>9</b>	<b>8</b>
<b>Name</b>	0	0	0	0	0	0	0	0
<b>Bit</b>	<b>7</b>	<b>6</b>	<b>5</b>	<b>4</b>	<b>3</b>	<b>2</b>	<b>1</b>	<b>0</b>
<b>Name</b>	0	0	0	0	INT_IRQDFLAG	INT_IRQCFLAG	INT_IRQBFLAG	INT_IRQAFLAG

Address: 0x4000A814 Reset: 0x0

Bitname	Bitfield	Access	Description
INT_IRQDFLAG	[3]	RW	IRQD interrupt pending. Write 1 to clear IRQD interrupt (writing 0 has no effect).
INT_IRQCFLAG	[2]	RW	IRQC interrupt pending. Write 1 to clear IRQC interrupt (writing 0 has no effect).
INT_IRQBFLAG	[1]	RW	IRQB interrupt pending. Write 1 to clear IRQB interrupt (writing 0 has no effect).
INT_IRQAFLAG	[0]	RW	IRQA interrupt pending. Write 1 to clear IRQA interrupt (writing 0 has no effect).

**Register 7.12. GPIO\_DBGCFG: GPIO Debug Configuration Register**

<b>Bit</b>	<b>31</b>	<b>30</b>	<b>29</b>	<b>28</b>	<b>27</b>	<b>26</b>	<b>25</b>	<b>24</b>
<b>Name</b>	0	0	0	0	0	0	0	0
<b>Bit</b>	<b>23</b>	<b>22</b>	<b>21</b>	<b>20</b>	<b>19</b>	<b>18</b>	<b>17</b>	<b>16</b>
<b>Name</b>	0	0	0	0	0	0	0	0
<b>Bit</b>	<b>15</b>	<b>14</b>	<b>13</b>	<b>12</b>	<b>11</b>	<b>10</b>	<b>9</b>	<b>8</b>
<b>Name</b>	0	0	0	0	0	0	0	0
<b>Bit</b>	<b>7</b>	<b>6</b>	<b>5</b>	<b>4</b>	<b>3</b>	<b>2</b>	<b>1</b>	<b>0</b>
<b>Name</b>	0	0	GPIO_DEBUGDIS	GPIO_EXTREGEN	GPIO_DBGCFGRSVD	0	0	0

Address: 0x4000BC00 Reset: 0x10

Bitname	Bitfield	Access	Description
GPIO_DEBUGDIS	[5]	RW	Disable debug interface override of normal GPIO configuration. 0: Permit debug interface to be active. 1: Disable debug interface (if it is not already active).
GPIO_EXTREGEN	[4]	RW	Enable REG_EN override of PA7's normal GPIO configuration. 0: Disable override. 1: Enable override.
GPIO_DBGCFGRSVD	[3]	RW	Reserved: this bit can change during normal operation. When writing to GPIO_DBGCFG, the value of this bit must be preserved.

**Register 7.13. GPIO\_DBGSTAT: GPIO Debug Status Register**

<b>Bit</b>	<b>31</b>	<b>30</b>	<b>29</b>	<b>28</b>	<b>27</b>	<b>26</b>	<b>25</b>	<b>24</b>
<b>Name</b>	0	0	0	0	0	0	0	0
<b>Bit</b>	<b>23</b>	<b>22</b>	<b>21</b>	<b>20</b>	<b>19</b>	<b>18</b>	<b>17</b>	<b>16</b>
<b>Name</b>	0	0	0	0	0	0	0	0
<b>Bit</b>	<b>15</b>	<b>14</b>	<b>13</b>	<b>12</b>	<b>11</b>	<b>10</b>	<b>9</b>	<b>8</b>
<b>Name</b>	0	0	0	0	0	0	0	0
<b>Bit</b>	<b>7</b>	<b>6</b>	<b>5</b>	<b>4</b>	<b>3</b>	<b>2</b>	<b>1</b>	<b>0</b>
<b>Name</b>	0	0	0	0	GPIO_BOOTMODE	0	GPIO_FORCEDBG	GPIO_SWEN

Address: 0x4000BC04 Reset: 0x0

<b>Bitname</b>	<b>Bitfield</b>	<b>Access</b>	<b>Description</b>
GPIO_BOOTMODE	[3]	R	The state of the nBOOTMODE signal sampled at the end of reset. 0: nBOOTMODE was not asserted (it read high). 1: nBOOTMODE was asserted (it read low).
GPIO_FORCEDBG	[1]	R	Status of debugger interface. 0: Debugger interface not forced active. 1: Debugger interface forced active by debugger cable.
GPIO_SWEN	[0]	R	Status of Serial Wire interface. 0: Not enabled by SWJ-DP. 1: Enabled by SWJ-DP.

## 8. Serial Controllers

### 8.1. Overview

The EM341 has two serial controllers, SC1 and SC2, which provide several options for full-duplex synchronous and asynchronous serial communications.

- SPI (Serial Peripheral Interface), master or slave
- TWI (Two Wire serial Interface), master only
- UART (Universal Asynchronous Receiver/Transmitter), SC1 only
- Receive and transmit FIFOs and DMA channels, SPI and UART modes

Receive and transmit FIFOs allow faster data speeds using byte-at-a-time interrupts. For the highest SPI and UART speeds, dedicated receive and transmit DMA channels reduce CPU loading and extend the allowable time to service a serial controller interrupt. Polled operation is also possible using direct access to the serial data registers. Figure 8.1 shows the components of the serial controllers.

**Note:** The notation SC<sub>x</sub> means that either SC1 or SC2 may be substituted to form the name of a specific register or field within a register.

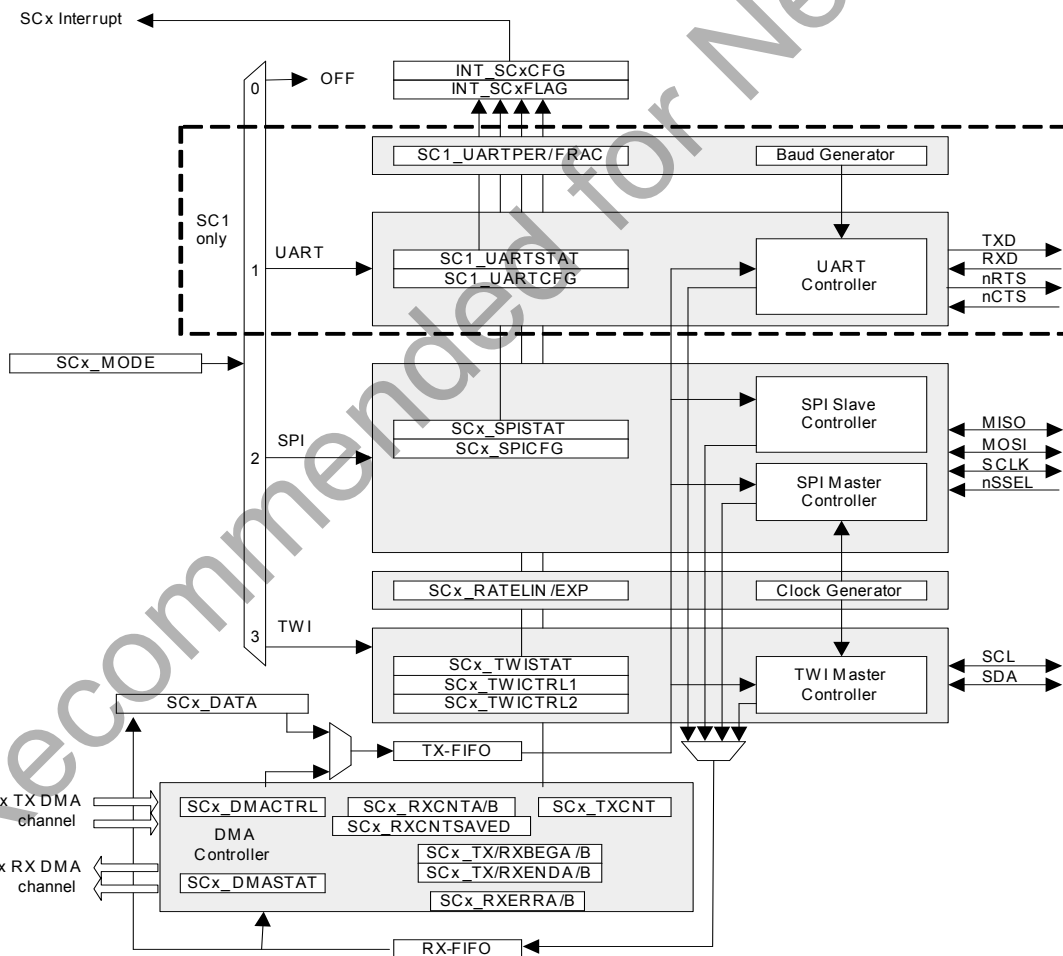

Figure 8.1. Serial Controller Block Diagram

## 8.2. Configuration

Before using a serial controller, configure and initialize it as follows:

1. Set up the parameters specific to the operating mode (master/slave for SPI, baud rate for UART, etc.).
2. Configure the GPIO pins used by the serial controller as shown in Tables 8.1 and 8.2. "7.2. Configuration" on page 49 shows how to configure GPIO pins.
3. If using DMA, set up the DMA and buffers. This is described fully in "8.7. DMA Channels" on page 99.
4. If using interrupts, select edge- or level-triggered interrupts with the SCx\_INTMODE register, enable the desired second-level interrupt sources in the INT\_SCxCFG register, and finally enable the top-level SCx interrupt in the NVIC.
5. Write the serial interface operating mode (SPI, TWI, or UART) to the SCx\_MODE register.

**Table 8.1. SC1 GPIO Usage and Configuration**

	PB1	PB2	PB3	PB4
<b>SPI - Master</b>	SC1MOSI Alternate Output (push-pull)	SC1MISO Input	SC1SCLK Alternate Output (push-pull)	(not used)
<b>SPI - Slave</b>	SC1MISO Alternate Output (push-pull)	SC1MOSI Input	SC1SCLK Input	SC1nSSEL Input
<b>TWI - Master</b>	SC1SDA Alternate Output (open-drain)	SC1SCL Alternate Output (open-drain)	(not used)	(not used)
<b>UART</b>	TXD Alternate Output (push-pull)	RXD Input	nCTS Input <sup>1</sup>	nRTS Alternate Output (push-pull) <sup>*</sup>

**\*Note:** used if RTS/CTS hardware flow control is enabled.

**Table 8.2. SC2 GPIO Usage and Configuration**

	PA0	PA1	PA2	PA3
<b>SPI - Master</b>	SC2MOSI Alternate Output (push-pull)	SC2MISO Input	SC2SCLK Alternate Output (push-pull)	(not used)
<b>SPI - Slave</b>	SC2MOSI Input	SC2MISO Alternate Output (push-pull)	SC2SCLK Input	SC2nSSEL Input
<b>TWI - Master</b>	(not used)	SC2SDA Alternate Output (open-drain)	SC2SCL Alternate Output (open-drain)	(not used)

# EM341

## 8.2.1. Registers

**Note:** Substitute "1" or "2" for "x" in the following detailed descriptions.

### Register 8.1. SCx\_MODE

**SC1\_MODE:** Serial Mode Register

**SC2\_MODE:** Serial Mode Register

<b>Bit</b>	<b>31</b>	<b>30</b>	<b>29</b>	<b>28</b>	<b>27</b>	<b>26</b>	<b>25</b>	<b>24</b>
<b>Name</b>	0	0	0	0	0	0	0	0
<b>Bit</b>	<b>23</b>	<b>22</b>	<b>21</b>	<b>20</b>	<b>19</b>	<b>18</b>	<b>17</b>	<b>16</b>
<b>Name</b>	0	0	0	0	0	0	0	0
<b>Bit</b>	<b>15</b>	<b>14</b>	<b>13</b>	<b>12</b>	<b>11</b>	<b>10</b>	<b>9</b>	<b>8</b>
<b>Name</b>	0	0	0	0	0	0	0	0
<b>Bit</b>	<b>7</b>	<b>6</b>	<b>5</b>	<b>4</b>	<b>3</b>	<b>2</b>	<b>1</b>	<b>0</b>
<b>Name</b>	0	0	0	0	0	0	SC_MODE	

SC1\_MODE: Address: 0x4000C854 Reset: 0x0

SC2\_MODE: Address: 0x4000C054 Reset: 0x0

<b>Bitname</b>	<b>Bitfield</b>	<b>Access</b>	<b>Description</b>
SC_MODE	[1:0]	RW	Serial controller mode. 0: Disabled. 1: UART mode (valid only for SC1). 2: SPI mode. 3: TWI mode.

**Register 8.2. INT\_SCxFLAG****INT\_SC1FLAG: Serial Controller 1 Interrupt Flag Register****INT\_SC2FLAG: Serial Controller 2 Interrupt Flag Register**

<b>Bit</b>	<b>31</b>	<b>30</b>	<b>29</b>	<b>28</b>	<b>27</b>	<b>26</b>	<b>25</b>	<b>24</b>
<b>Name</b>	0	0	0	0	0	0	0	0
<b>Bit</b>	<b>23</b>	<b>22</b>	<b>21</b>	<b>20</b>	<b>19</b>	<b>18</b>	<b>17</b>	<b>16</b>
<b>Name</b>	0	0	0	0	0	0	0	0
<b>Bit</b>	<b>15</b>	<b>14</b>	<b>13</b>	<b>12</b>	<b>11</b>	<b>10</b>	<b>9</b>	<b>8</b>
<b>Name</b>	0	INT_ SC1PARERR	INT_ SC1FRMERR	INT_ SCTXULDB	INT_ SCTXULDA	INT_ SCRXLDB	INT_ SCRXLDA	INT_ SCNAK
<b>Bit</b>	<b>7</b>	<b>6</b>	<b>5</b>	<b>4</b>	<b>3</b>	<b>2</b>	<b>1</b>	<b>0</b>
<b>Name</b>	INT_ SCCMDFIN	INT_ SCTXFIN	INT_ SCRXFIN	INT_ SCTXUND	INT_ SCRXOVF	INT_ SCTXIDLE	INT_ SCTXFREE	INT_ SCRXVAL

INT\_SC1FLAG: Address: 0x4000A808 Reset: 0x0

INT\_SC2FLAG: Address: 0x4000A80C Reset: 0x0

<b>Bitname</b>	<b>Bitfield</b>	<b>Access</b>	<b>Description</b>
INT_SC1PARERR	[14]	RW	Parity error received (UART) interrupt pending.
INT_SC1FRMERR	[13]	RW	Frame error received (UART) interrupt pending.
INT_SCTXULDB	[12]	RW	DMA transmit buffer B unloaded interrupt pending.
INT_SCTXULDA	[11]	RW	DMA transmit buffer A unloaded interrupt pending.
INT_SCRXLDB	[10]	RW	DMA receive buffer B unloaded interrupt pending.
INT_SCRXLDA	[9]	RW	DMA receive buffer A unloaded interrupt pending.
INT_SCNAK	[8]	RW	NACK received (TWI) interrupt pending.
INT_SCCMDFIN	[7]	RW	START/STOP command complete (TWI) interrupt pending.
INT_SCTXFIN	[6]	RW	Transmit operation complete (TWI) interrupt pending.
INT_SCRXFIN	[5]	RW	Receive operation complete (TWI) interrupt pending.
INT_SCTXUND	[4]	RW	Transmit buffer underrun interrupt pending.
INT_SCRXOVF	[3]	RW	Receive buffer overrun interrupt pending.
INT_SCTXIDLE	[2]	RW	Transmitter idle interrupt pending.
INT_SCTXFREE	[1]	RW	Transmit buffer free interrupt pending.
INT_SCRXVAL	[0]	RW	Receive buffer has data interrupt pending.

# EM341

## Register 8.3. INT\_SCxCFG

INT\_SC1CFG: Serial Controller 1 Interrupt Configuration Register

INT\_SC2CFG: Serial Controller 2 Interrupt Configuration Register

<b>Bit</b>	<b>31</b>	<b>30</b>	<b>29</b>	<b>28</b>	<b>27</b>	<b>26</b>	<b>25</b>	<b>24</b>
<b>Name</b>	0	0	0	0	0	0	0	0
<b>Bit</b>	<b>23</b>	<b>22</b>	<b>21</b>	<b>20</b>	<b>19</b>	<b>18</b>	<b>17</b>	<b>16</b>
<b>Name</b>	0	0	0	0	0	0	0	0
<b>Bit</b>	<b>15</b>	<b>14</b>	<b>13</b>	<b>12</b>	<b>11</b>	<b>10</b>	<b>9</b>	<b>8</b>
<b>Name</b>	0	INT_ SC1PARERR	INT_ SC1FRMERR	INT_ SCTXULDB	INT_ SCTXULDA	INT_ SCRULDB	INT_ SCRULDA	INT_ SCNAK
<b>Bit</b>	<b>7</b>	<b>6</b>	<b>5</b>	<b>4</b>	<b>3</b>	<b>2</b>	<b>1</b>	<b>0</b>
<b>Name</b>	INT_ SCCMDFIN	INT_ SCTXFIN	INT_ SCRXFIN	INT_ SCTXUND	INT_ SCRXOVF	INT_ SCTXIDLE	INT_ SCTXFREE	INT_ SCRXVAL

INT\_SC1CFG: Address: 0x4000A848 Reset: 0x0

INT\_SC2CFG: Address: 0x4000A84C Reset: 0x0

Bitname	Bitfield	Access	Description
INT_SC1PARERR	[14]	RW	Parity error received (UART) interrupt enable.
INT_SC1FRMERR	[13]	RW	Frame error received (UART) interrupt enable.
INT_SCTXULDB	[12]	RW	DMA transmit buffer B unloaded interrupt enable.
INT_SCTXULDA	[11]	RW	DMA transmit buffer A unloaded interrupt enable.
INT_SCRULDB	[10]	RW	DMA receive buffer B unloaded interrupt enable.
INT_SCRULDA	[9]	RW	DMA receive buffer A unloaded interrupt enable.
INT_SCNAK	[8]	RW	NACK received (TWI) interrupt enable.
INT_SCCMDFIN	[7]	RW	START/STOP command complete (TWI) interrupt enable.
INT_SCTXFIN	[6]	RW	Transmit operation complete (TWI) interrupt enable.
INT_SCRXFIN	[5]	RW	Receive operation complete (TWI) interrupt enable.
INT_SCTXUND	[4]	RW	Transmit buffer underrun interrupt enable.
INT_SCRXOVF	[3]	RW	Receive buffer overrun interrupt enable.
INT_SCTXIDLE	[2]	RW	Transmitter idle interrupt enable.
INT_SCTXFREE	[1]	RW	Transmit buffer free interrupt enable.
INT_SCRXVAL	[0]	RW	Receive buffer has data interrupt enable.

**Register 8.4. SCx\_INTMODE****SC1\_INTMODE: Serial Controller 1 Interrupt Mode Register****SC2\_INTMODE: Serial Controller 2 Interrupt Mode Register**

<b>Bit</b>	<b>31</b>	<b>30</b>	<b>29</b>	<b>28</b>	<b>27</b>	<b>26</b>	<b>25</b>	<b>24</b>
<b>Name</b>	0	0	0	0	0	0	0	0
<b>Bit</b>	<b>23</b>	<b>22</b>	<b>21</b>	<b>20</b>	<b>19</b>	<b>18</b>	<b>17</b>	<b>16</b>
<b>Name</b>	0	0	0	0	0	0	0	0
<b>Bit</b>	<b>15</b>	<b>14</b>	<b>13</b>	<b>12</b>	<b>11</b>	<b>10</b>	<b>9</b>	<b>8</b>
<b>Name</b>	0	0	0	0	0	0	0	0
<b>Bit</b>	<b>7</b>	<b>6</b>	<b>5</b>	<b>4</b>	<b>3</b>	<b>2</b>	<b>1</b>	<b>0</b>
<b>Name</b>	0	0	0	0	0	SC_TXIDLELEVEL	SC_TXFREELEVEL	SC_RXVALLEVEL

SC1\_INTMODE: Address: 0x4000A854 Reset: 0x0

SC2\_INTMODE: Address: 0x4000A858 Reset: 0x0

<b>Bitname</b>	<b>Bitfield</b>	<b>Access</b>	<b>Description</b>
SC_TXIDLELEVEL	[2]	RW	Transmitter idle interrupt mode - 0: edge triggered, 1: level triggered.
SC_TXFREELEVEL	[1]	RW	Transmit buffer free interrupt mode - 0: edge triggered, 1: level triggered.
SC_RXVALLEVEL	[0]	RW	Receive buffer has data interrupt mode - 0: edge triggered, 1: level triggered.



## 8.3. SPI—Master Mode

The SPI master controller has the following features:

- Full duplex operation
- Programmable clock frequency (12 MHz max.)
- Programmable clock polarity and phase
- Selectable data shift direction (either LSB or MSB first)
- Receive and transmit FIFOs
- Receive and transmit DMA channels

### 8.3.1. GPIO Usage

The SPI master controller uses the three signals:

- MOSI (Master Out, Slave In) - outputs serial data from the master
- MISO (Master In, Slave Out) - inputs serial data from a slave
- SCLK (Serial Clock) - outputs the serial clock used by MOSI and MISO

The GPIO pins used for these signals are shown in Table 8.3. Additional outputs may be needed to drive the nSSEL signals on slave devices.

**Table 8.3. SPI Master GPIO Usage**

	MOSI	MISO	SCLK
<b>Direction</b>	Output	Input	Output
<b>GPIO Configuration</b>	Alternate Output (push-pull)	Input	Alternate Output (push-pull)
<b>SC1 pin</b>	PB1	PB2	PB3
<b>SC2 pin</b>	PA0	PA1	PA2

### 8.3.2. Set Up and Configuration

Both serial controllers, SC1 and SC2, support SPI master mode. SPI master mode is enabled by the following register settings:

- The serial controller mode register (SCx\_MODE) is 2.
- The SC\_SPIMST bit in the SPI configuration register (SCx\_SPICFG) is 1.

The SPI serial clock (SCLK) is produced by a programmable clock generator. The serial clock is produced by dividing down 12 MHz according to this equation:

$$\text{rate} = \frac{12 \text{ MHz}}{(\text{LIN} + 1) \times 2^{\text{EXP}}}$$

EXP is the value written to the SCx\_RATEEXP register, and LIN is the value written to the SCx\_RATELIN register. EXP and LIN can both be zero, so the SPI master mode clock may be 12 Mbps.

The SPI master controller supports various frame formats depending upon the clock polarity (SC\_SPIPOL), clock phase (SC\_SPIPHA), and direction of data (SC\_SPIORD) (see Table 8.4). The bits SC\_SPIPOL, SC\_SPIPHA, and SC\_SPIORD are defined within the SCx\_SPICFG register.

Table 8.4. SPI Master Mode Formats

SCx_SPICFG				Frame Formats
SC_SPlxxx*				
MST	ORD	PHA	POL	
1	0	0	0	
1	0	0	1	
1	0	1	0	
1	0	1	1	
1	1	—	—	Same as above except data is sent LSB first instead of MSB first

**\*Note:** The notation xxx means that the corresponding column header below is inserted to form the field name.

### 8.3.3. Operation

Characters transmitted and received by the SPI master controller are buffered in transmit and receive FIFOs that are both 4 entries deep. When software writes a character to the SCx\_DATA register, the character is pushed onto the transmit FIFO. Similarly, when software reads from the SCx\_DATA register, the character returned is pulled from the receive FIFO. If the transmit and receive DMA channels are used, they also write to and read from the transmit and receive FIFOs.

When the transmit FIFO and the serializer are both empty, writing a character to the transmit FIFO clears the SC\_SPITXIDLE bit in the SCx\_SPISTAT register. This indicates that some characters have not yet been transmitted. If characters are written to the transmit FIFO until it is full, the SC\_SPITXFREE bit in the SCx\_SPISTAT register is cleared. Shifting out a character to the MOSI pin sets the SC\_SPITXFREE bit in the SCx\_SPISTAT register. When the transmit FIFO empties and the last character has been shifted out, the SC\_SPITXIDLE bit in the SCx\_SPISTAT register is set.

Characters received are stored in the receive FIFO. Receiving characters sets the SC\_SPIRXVAL bit in the SCx\_SPISTAT register, indicating that characters can be read from the receive FIFO. Characters received while the receive FIFO is full are dropped, and the SC\_SPIRXOVF bit in the SCx\_SPISTAT register is set. The receive FIFO hardware generates the INT\_SCRXOVF interrupt, but the DMA register will not indicate the error condition until the receive FIFO is drained. Once the DMA marks a receive error, two conditions will clear the error indication: setting the appropriate SC\_TX/RXDMA\_RST bit in the SCx\_DMACTRL register, or loading the appropriate DMA buffer after it has unloaded.

To receive a character, you must transmit a character. If a long stream of receive characters is expected, a long sequence of dummy transmit characters must be generated. To avoid software or transmit DMA initiating these transfers and consuming unnecessary bandwidth, the SPI serializer can be instructed to retransmit the last

transmitted character or to transmit a busy token (0xFF), which is determined by the SC\_SPIRPT bit in the SCx\_SPICFG register. This functionality can only be enabled or disabled when the transmit FIFO is empty and the transmit serializer is idle, indicated by a cleared SC\_SPITXIDLE bit in the SCx\_SPISTAT register. Refer to the register description of SCx\_SPICFG for more detailed information about SC\_SPIRPT.

Every time an automatic character transmission starts, a transmit underrun is detected as there is no data in transmit FIFO, and the INT\_SCTXUND bit in the INT\_SC2FLAG register is set. After automatic character transmission is disabled, no more new characters are received. The receive FIFO holds characters just received.

**Note:** The Receive DMA complete event does not always mean the receive FIFO is empty.

"8.7. DMA Channels" on page 99 describes how to configure and use the serial receive and transmit DMA channels.

### 8.3.4. Interrupts

SPI master controller second-level interrupts are generated by the following events:

- Transmit FIFO empty and last character shifted out (depending on SCx\_INTMODE, either the 0 to 1 transition or the high level of SC\_SPITXIDLE)
- Transmit FIFO changed from full to not full (depending on SCx\_INTMODE, either the 0 to 1 transition or the high level of SC\_SPITXFREE)
- Receive FIFO changed from empty to not empty (depending on SCx\_INTMODE, either the 0 to 1 transition or the high level of SC\_SPIRXVAL)
- Transmit DMA buffer A/B complete (1 to 0 transition of SC\_TXACTA/B)
- Receive DMA buffer A/B complete (1 to 0 transition of SC\_RXACTA/B)
- Received and lost character while receive FIFO was full (receive overrun error)
- Transmitted character while transmit FIFO was empty (transmit underrun error)

To enable CPU interrupts, set the desired interrupt bits in the second-level INT\_SCxCFG register, and enable the top-level SCx interrupt in the NVIC by writing the INT\_SCx bit in the INT\_CFGSET register.

### 8.3.5. Registers

**Note:** Substitute “1” or “2” for “x” in the following detailed descriptions.

#### Register 8.5. SC<sub>x</sub>\_DATA

SC1\_DATA: Serial Data Register

SC2\_DATA: Serial Data Register

<b>Bit</b>	<b>31</b>	<b>30</b>	<b>29</b>	<b>28</b>	<b>27</b>	<b>26</b>	<b>25</b>	<b>24</b>
<b>Name</b>	0	0	0	0	0	0	0	0
<b>Bit</b>	<b>23</b>	<b>22</b>	<b>21</b>	<b>20</b>	<b>19</b>	<b>18</b>	<b>17</b>	<b>16</b>
<b>Name</b>	0	0	0	0	0	0	0	0
<b>Bit</b>	<b>15</b>	<b>14</b>	<b>13</b>	<b>12</b>	<b>11</b>	<b>10</b>	<b>9</b>	<b>8</b>
<b>Name</b>	0	0	0	0	0	0	0	0
<b>Bit</b>	<b>7</b>	<b>6</b>	<b>5</b>	<b>4</b>	<b>3</b>	<b>2</b>	<b>1</b>	<b>0</b>
<b>Name</b>	SC_DATA							

SC1\_DATA: Address: 0x4000C83C Reset: 0x0

SC2\_DATA: Address: 0x4000C03C Reset: 0x0

Bitname	Bitfield	Access	Description
SC_DATA	[7:0]	RW	Transmit and receive data register. Writing to this register adds a byte to the transmit FIFO. Reading from this register takes the next byte from the receive FIFO and clears the overrun error bit if it was set. In UART mode (SC1 only), reading from this register loads the UART status register with the parity and frame error status of the next byte in the FIFO, and clears these bits if the FIFO is now empty.

# EM341

## Register 8.6. SCx\_SPICFG

SC1SPICFG: SPI Configuration Register

SC2SPICFG: SPI Configuration Register

<b>Bit</b>	<b>31</b>	<b>30</b>	<b>29</b>	<b>28</b>	<b>27</b>	<b>26</b>	<b>25</b>	<b>24</b>
<b>Name</b>	0	0	0	0	0	0	0	0
<b>Bit</b>	<b>23</b>	<b>22</b>	<b>21</b>	<b>20</b>	<b>19</b>	<b>18</b>	<b>17</b>	<b>16</b>
<b>Name</b>	0	0	0	0	0	0	0	0
<b>Bit</b>	<b>15</b>	<b>14</b>	<b>13</b>	<b>12</b>	<b>11</b>	<b>10</b>	<b>9</b>	<b>8</b>
<b>Name</b>	0	0	0	0	0	0	0	0
<b>Bit</b>	<b>7</b>	<b>6</b>	<b>5</b>	<b>4</b>	<b>3</b>	<b>2</b>	<b>1</b>	<b>0</b>
<b>Name</b>	0	0	SC_SPIRXDRV	SC_SPIMST	SC_SPIRPT	SC_SPIORD	SC_SPIPHA	SC_SPIPOL

SC1SPICFG: Address: 0x4000C858 Reset: 0x0

SC2SPICFG: Address: 0x4000C058 Reset: 0x0

Bitname	Bitfield	Access	Description
SC_SPIRXDRV	[5]	RW	Receiver-driven mode selection bit (SPI master mode only). Clear this bit to initiate transactions when transmit data is available. Set this bit to initiate transactions when the receive buffer (FIFO or DMA) has space.
SC_SPIMST	[4]	RW	Set this bit to put the SPI in master mode, clear this bit to put the SPI in slave mode.
SC_SPIRPT	[3]	RW	This bit controls behavior when the transmit serializer must send a byte and there is no data already available in/to the serializer. The conditions for sending this “busy” token are transmit buffer underrun condition when using DMA in master or slave mode, empty FIFO in slave mode, and the busy token will always be sent as the first byte every time nSSEL is asserted while operating in slave mode. Clear this bit to send the BUSY token (0xFF) and set this bit to repeat the last byte. Changes to this bit take effect when the transmit FIFO is empty and the transmit serializer is idle. Note that when the chip comes out of reset, if SC_SPIRPT is set before any data has been transmitted and no data is available (in the FIFO), the “last byte” that will be transmitted after the padding byte is 0x00 due to the FIFO having been reset to 0x00.
SC_SPIORD	[2]	RW	This bit specifies the bit order in which SPI data is transmitted and received. 0: Most significant bit first. 1: Least significant bit first.
SC_SPIPHA	[1]	RW	Clock phase configuration: clear this bit to sample on the leading (first edge) and set this bit to sample on the second edge.
SC_SPIPOL	[0]	RW	Clock polarity configuration: clear this bit for a rising leading edge and set this bit for a falling leading edge.

**Register 8.7. SCx\_SPISTAT****SC1\_SPISTAT: SPI Status Register****SC2\_SPISTAT: SPI Status Register**

<b>Bit</b>	<b>31</b>	<b>30</b>	<b>29</b>	<b>28</b>	<b>27</b>	<b>26</b>	<b>25</b>	<b>24</b>
<b>Name</b>	0	0	0	0	0	0	0	0
<b>Bit</b>	<b>23</b>	<b>22</b>	<b>21</b>	<b>20</b>	<b>19</b>	<b>18</b>	<b>17</b>	<b>16</b>
<b>Name</b>	0	0	0	0	0	0	0	0
<b>Bit</b>	<b>15</b>	<b>14</b>	<b>13</b>	<b>12</b>	<b>11</b>	<b>10</b>	<b>9</b>	<b>8</b>
<b>Name</b>	0	0	0	0	0	0	0	0
<b>Bit</b>	<b>7</b>	<b>6</b>	<b>5</b>	<b>4</b>	<b>3</b>	<b>2</b>	<b>1</b>	<b>0</b>
<b>Name</b>	0	0	0	0	SC_SPITXIDLE	SC_SPITXFREE	SC_SPIRXVAL	SC_SPIRXOVF

SC1\_SPISTAT: Address: 0x4000C840 Reset: 0x0

SC2\_SPISTAT: Address: 0x4000C040 Reset: 0x0

<b>Bitname</b>	<b>Bitfield</b>	<b>Access</b>	<b>Description</b>
SC_SPITXIDLE	[3]	R	This bit is set when both the transmit FIFO and the transmit serializer are empty.
SC_SPITXFREE	[2]	R	This bit is set when the transmit FIFO has space to accept at least one byte.
SC_SPIRXVAL	[1]	R	This bit is set when the receive FIFO contains at least one byte.
SC_SPIRXOVF	[0]	R	This bit is set if a byte is received when the receive FIFO is full. This bit is cleared by reading the data register.

# EM341

## Register 8.8. SCx\_RATELIN

SC1\_RATELIN: Serial Clock Linear Prescaler Register

SC2\_RATELIN: Serial Clock Linear Prescaler Register

Bit	31	30	29	28	27	26	25	24
Name	0	0	0	0	0	0	0	0
Bit	23	22	21	20	19	18	17	16
Name	0	0	0	0	0	0	0	0
Bit	15	14	13	12	11	10	9	8
Name	0	0	0	0	0	0	0	0
Bit	7	6	5	4	3	2	1	0
Name	0	0	0	0	SC_RATELIN			

SC1\_RATELIN: Address: 0x4000C860 Reset: 0x0

SC2\_RATELIN: Address: 0x4000C060 Reset: 0x0

Bitname	Bitfield	Access	Description
SC_RATELIN	[3:0]	RW	<p>The linear component (LIN) of the clock rate in the equation:</p> $\text{rate} = \frac{12 \text{ MHz}}{(\text{LIN} + 1) \times 2^{\text{EXP}}}$

**Register 8.9. SCx\_RATEEXP****SC1\_RATEEXP: Serial Clock Exponential Prescaler Register****SC2\_RATEEXP: Serial Clock Exponential Prescaler Register**

<b>Bit</b>	<b>31</b>	<b>30</b>	<b>29</b>	<b>28</b>	<b>27</b>	<b>26</b>	<b>25</b>	<b>24</b>
<b>Name</b>	0	0	0	0	0	0	0	0
<b>Bit</b>	<b>23</b>	<b>22</b>	<b>21</b>	<b>20</b>	<b>19</b>	<b>18</b>	<b>17</b>	<b>16</b>
<b>Name</b>	0	0	0	0	0	0	0	0
<b>Bit</b>	<b>15</b>	<b>14</b>	<b>13</b>	<b>12</b>	<b>11</b>	<b>10</b>	<b>9</b>	<b>8</b>
<b>Name</b>	0	0	0	0	0	0	0	0
<b>Bit</b>	<b>7</b>	<b>6</b>	<b>5</b>	<b>4</b>	<b>3</b>	<b>2</b>	<b>1</b>	<b>0</b>
<b>Name</b>	0	0	0	0	SC_RATEEXP			

SC1\_RATEEXP: Address: 0x4000C864 Reset: 0x0

SC2\_RATEEXP: Address: 0x4000C064 Reset: 0x0

<b>Bitname</b>	<b>Bitfield</b>	<b>Access</b>	<b>Description</b>
SC_RATEEXP	[3:0]	RW	The exponential component (EXP) of the clock rate in the equation: $\text{rate} = \frac{12 \text{ MHz}}{(\text{LIN} + 1) \times 2^{\text{EXP}}}$



## 8.4. SPI—Slave Mode

Both SC1 and SC2 SPI controllers include an SPI slave controller with these features:

- Full duplex operation
- Up to 5 Mbps data transfer rate
- Programmable clock polarity and clock phase
- Selectable data shift direction (either LSB or MSB first)
- Slave select input

### 8.4.1. GPIO Usage

The SPI slave controller uses four signals:

- MOSI (Master Out, Slave In) - inputs serial data from the master
- MISO (Master In, Slave Out) - outputs serial data to the master
- SCLK (Serial Clock) - clocks data transfers on MOSI and MISO
- nSSEL (Slave Select) - enables serial communication with the slave

**Note:** The SPI slave controller does not tri-state the MISO signal when slave select is deasserted.

The GPIO pins that can be assigned to these signals are shown in Table 8.5.

**Table 8.5. SPI Slave GPIO Usage**

	<b>MOSI</b>	<b>MISO</b>	<b>SCLK</b>	<b>nSSEL</b>
<b>Direction</b>	Input	Output	Input	Input
<b>GPIO Configuration</b>	Input	Alternate Output (push-pull)	Input	Input
<b>SC1 pin</b>	PB2	PB1	PB3	PB4
<b>SC2 pin</b>	PA0	PA1	PA2	PA3

### 8.4.2. Set Up and Configuration

Both serial controllers, SC1 and SC2, support SPI slave mode. SPI slave mode is enabled by the following register settings:

- The serial controller mode register, SCx\_MODE, is 2
- The SC\_SPIMST bit in the SPI configuration register, SCx\_SPICFG, is 0

The SPI slave controller receives its clock from an external SPI master device and supports rates up to 5 Mbps.

The SPI slave controller supports various frame formats depending upon the clock polarity (SC\_SPIPOL), clock phase (SC\_SPIPHA), and direction of data (SC\_SPIORD) (see Table 8.6). The SC\_SPIPOL, SC\_SPIPHA, and SC\_SPIORD bits are defined within the SCx\_SPICFG registers.

**Table 8.6. SPI Slave Formats**

SCx_SPICFG				Frame Format
SC_SPIxxx*				
MST	ORD	PHA	POL	
0	0	0	0	
0	0	0	1	
0	0	1	0	
0	0	1	1	
0	1	—	—	Same as above except LSB first instead of MSB first

**\*Note:** The notation “xxx” means that the corresponding column header below is inserted to form the field name.

### 8.4.3. Operation

When the slave select (nSSEL) signal is asserted by the master, SPI transmit data is driven to the output pin MISO, and SPI data is received from the input pin MOSI. The nSSEL pin has to be asserted to enable the transmit serializer to drive data to the output signal MISO. A falling edge on nSSEL resets the SPI slave shift registers.

**Note:** The SPI slave controller does not tri-state the MISO signal when slave select is deasserted.

Characters transmitted and received by the SPI slave controller are buffered in the transmit and receive FIFOs that are both four entries deep. When software writes a character to the SCx\_DATA register, it is pushed onto the transmit FIFO. Similarly, when software reads from the SCx\_DATA register, the character returned is pulled from the receive FIFO. If the transmit and receive DMA channels are used, the DMA channels also write to and read from the transmit and receive FIFOs.

Characters received are stored in the receive FIFO. Receiving characters sets the SC\_SPIRXVAL bit in the SCx\_SPISTAT register, to indicate that characters can be read from the receive FIFO. Characters received while the receive FIFO is full are dropped, and the SC\_SPIRXOVF bit in the SCx\_SPISTAT register is set. The receive FIFO hardware generates the INT\_SCRXOVF interrupt, but the DMA register will not indicate the error condition until the receive FIFO is drained. Once the DMA marks a receive error, two conditions will clear the error indication: setting the appropriate SC\_TX/RXDMAST bit in the SCx\_DMACTRL register, or loading the appropriate DMA buffer after it has unloaded.

Receiving a character causes the serial transmission of a character pulled from the transmit FIFO. When the transmit FIFO is empty, a transmit underrun is detected (no data in transmit FIFO) and the INT\_SCTXUND bit in the INT\_SCXFLAG register is set. Because no character is available for serialization, the SPI serializer retransmits the last transmitted character or a busy token (0xFF), determined by the SC\_SPIRPT bit in the SCx\_SPICFG register. Refer to the register description of SCx\_SPICFG for more detailed information about SC\_SPIRPT.

When the transmit FIFO and the serializer are both empty, writing a character to the transmit FIFO clears the SC\_SPITXIDLE bit in the SCx\_SPISTAT register. This indicates that not all characters have been transmitted. If characters are written to the transmit FIFO until it is full, the SC\_SPITXFREE bit in the SCx\_SPISTAT register is cleared. Shifting out a transmit character to the MISO pin causes the SC\_SPITXFREE bit in the SCx\_SPISTAT register to get set. When the transmit FIFO empties and the last character has been shifted out, the SC\_SPITXIDLE bit in the SCx\_SPISTAT register is set.

The SPI slave controller must guarantee that there is time to move new transmit data from the transmit FIFO into the hardware serializer. To provide sufficient time, the SPI slave controller inserts a byte of padding at the start of every new string of transmit data defined by every time nSSEL is asserted. This byte is inserted as if this byte was placed there by software. The value of the byte of padding is always 0xFF.

### 8.4.4. DMA

The DMA Channels "8.7. DMA Channels" on page 99 describes how to configure and use the serial receive and transmit DMA channels.

When using the receive DMA channel and nSSEL transitions to the high (deasserted) state, the active buffer's receive DMA count register (SCx\_RXCNTA/B) is saved in the SCx\_RXCNTSAVED register. SCx\_RXCNTSAVED is only written the first time nSSEL goes high after a buffer has been loaded. Subsequent rising edges set a status bit but are otherwise ignored. The 3-bit field SC\_RXSSEL in the SCx\_DMASTAT register records what, if anything, was saved to the SCx\_RXCNTSAVED register, and whether or not another rising edge occurred on nSSEL.

### 8.4.5. Interrupts

SPI slave controller second-level interrupts are generated on the following events:

- Transmit FIFO empty and last character shifted out (depending on SCx\_INTMODE, either the 0 to 1 transition or the high level of SC\_SPITXIDLE)
- Transmit FIFO changed from full to not full (depending on SCx\_INTMODE, either the 0 to 1 transition or the high level of SC\_SPITXFREE)
- Receive FIFO changed from empty to not empty (depending on SCx\_INTMODE, either the 0 to 1 transition or the high level of SC\_SPIRXVAL)
- Transmit DMA buffer A/B complete (1 to 0 transition of SC\_TXACTA/B)
- Receive DMA buffer A/B complete (1 to 0 transition of SC\_RXACTA/B)
- Received and lost character while receive FIFO was full (receive overrun error)
- Transmitted character while transmit FIFO was empty (transmit underrun error)

To enable CPU interrupts, set desired interrupt bits in the second-level INT\_SCxCFG register, and also enable the top-level SCx interrupt in the NVIC by writing the INT\_SCx bit in the INT\_CFGSET register.

### 8.4.6. Registers

Refer to Registers (in the SPI Master Mode "8.3. SPI—Master Mode" on page 74) for a description of the SCx\_DATA, SCx\_SPICFG, and SCx\_SPISTAT registers.

## 8.5. TWI—Two Wire Serial Interfaces

Both serial controllers SC1 and SC2 include a Two Wire serial Interface (TWI) master with the following features:

- Uses only two bidirectional GPIO pins
- Programmable clock frequency (up to 400 kHz)
- Supports both 7-bit and 10-bit addressing
- Compatible with Philips' I<sup>2</sup>C-bus slave devices

### 8.5.1. GPIO Usage

The TWI master controller uses just two signals:

- SDA (Serial Data) - bidirectional serial data
- SCL (Serial Clock) - bidirectional serial clock

Table 8.7 lists the GPIO pins used by the SC1 and SC2 TWI master controllers. Because the pins are configured as open-drain outputs, they require external pull-up resistors.

**Table 8.7. TWI Master GPIO Usage**

	SDA	SCL
<b>Direction</b>	Input / Output	Input / Output
<b>GPIO Configuration</b>	Alternate Output (Open Drain)	Alternate Output (Open Drain)
<b>SC1 Pin</b>	PB1	PB2
<b>SC2 Pin</b>	PA1	PA2

## 8.5.2. Set Up and Configuration

The TWI controller is enabled by writing 3 to the SCx\_MODE register. The TWI controller operates only in master mode and supports both Standard (100 kbps) and Fast (400 kbps) TWI modes. Address arbitration is not implemented, so multiple master applications are not supported.

The TWI master controller's serial clock (SCL) is produced by a programmable clock generator. SCL is produced by dividing down 12 MHz according to the following equation:

$$\text{rate} = \frac{12 \text{ MHz}}{(\text{LIN} + 1) \times 2^{\text{EXP}}}$$

EXP is the value written to the SCx\_RATEEXP register and LIN is the value written to the SCx\_RATELIN register. Table 8.8 shows the rate settings for Standard-Mode TWI (100 kbps) and Fast-Mode TWI (400 kbps) operation.

**Table 8.8. TWI Clock Rate Programming**

Clock Rate	SCx_RATELIN	SCx_RATEEXP
100 kbps	14	3
375 kbps*	15	1
400 kbps*	14	1

**\*Note:** At 400 kbps, the Philips I<sup>2</sup>C Bus specification requires the minimum low period of SCL to be 1.3 μs, but on the EM341 it is 1.25 μs. If a slave device requires strict compliance with SCL timing, the clock rate must be lowered to 375 kbps.

The EM341 supports clock stretching. The slave device can hold SCL low on any received or transmitted data bit. This inhibits further data transfers until SCL is allowed to go high again.

### 8.5.3. Constructing Frames

The TWI master controller supports generating various frame segments by means of the SC\_TWISTART, SC\_TWISTOP, SC\_TWISEND, and SC\_TWIRECV bits in the SCx\_TWICTRL1 registers. Table 8.9 summarizes these frames.

**Table 8.9. TWI Master Frame Segments**

SCx_TWICTRL1				Frame Segments
SC_TWIXxxx*				
START	SEND	RECV	STOP	
1	0	0	0	<div style="display: flex; justify-content: space-between;"> <div style="width: 45%;"> <p>TWI start segment</p> </div> <div style="width: 45%;"> <p>TWI re-start segment - after transmit or frame with NACK</p> </div> </div>
0	1	0	0	<div style="display: flex; justify-content: space-between;"> <div style="width: 45%;"> <p>TWI transmit segment - after (re-)start frame</p> </div> <div style="width: 45%;"> <p>TWI transmit segment - after transmit with ACK</p> </div> </div>
0	0	1	0	<div style="display: flex; justify-content: space-between;"> <div style="width: 45%;"> <p>TWI receive segment - transmit with ACK</p> </div> <div style="width: 45%;"> <p>TWI receive segment - after receive with ACK</p> </div> </div>
0	0	0	1	<p>TWI stop segment - after frame with NACK or stop</p>
0	0	0	0	No pending frame segment
1	1	—	—	Illegal
—	1	1	—	
—	—	1	1	
1	—	—	1	

**\*Note:** The notation “xxx” means that the corresponding column header below is inserted to form the field name.

Full TWI frames have to be constructed by software from individual TWI segments. All necessary segment transitions are shown in Figure 8.2. ACK or NACK generation of a TWI receive frame segment is determined with the SC\_TWIACK bit in the SCx\_TWICTRL2 register.

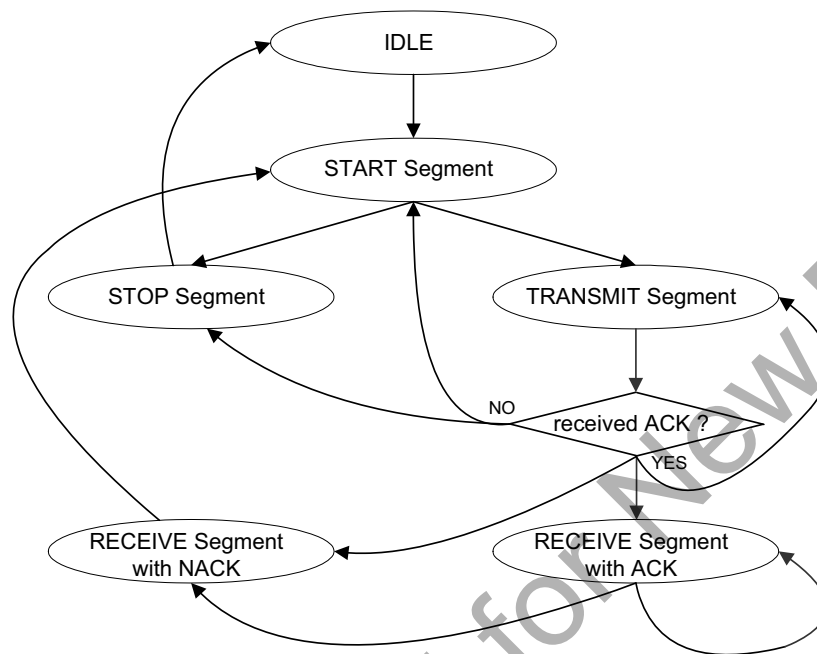

**Figure 8.2. TWI Segment Transitions**

Generation of a 7-bit address is accomplished with one transmit segment. The upper 7 bits of the transmitted character contain the 7-bit address. The remaining lower bit contains the command type (“read” or “write”).

Generation of a 10-bit address is accomplished with two transmit segments. The upper 5 bits of the first transmit character must be set to 0x1E. The next 2 bits are for the two most significant bits of the 10-bit address. The remaining lower bit contains the command type (“read” or “write”). The second transmit segment is for the remaining 8 bits of the 10-bit address.

Transmitted and received characters are accessed through the SCx\_DATA register.

To initiate (re)start and stop segments, set the SC\_TWISTART or SC\_TWISTOP bit in the SCx\_TWICTRL1 register, then wait until the bit is clear. Alternatively, the SC\_TWICMDFIN bit in the SCx\_TWISTAT can be used for waiting.

To initiate a transmit segment, write the data to the SCx\_DATA data register, then set the SC\_TWISEND bit in the SCx\_TWICTRL1 register, and finally wait until the bit is clear. Alternatively the SC\_TWITXFIN bit in the SCx\_TWISTAT register can be used for waiting.

To initiate a receive segment, set the SC\_TWIRECV bit in the SCx\_TWICTRL1 register, wait until it is clear, and then read from the SCx\_DATA register. Alternatively, the SC\_TWIRXFIN bit in the SCx\_TWISTAT register can be used for waiting. Now the SC\_TWIRXNAK bit in the SCx\_TWISTAT register indicates if a NACK or ACK was received from a TWI slave device.

### 8.5.4. Interrupts

TWI master controller interrupts are generated on the following events:

- Bus command (SC\_TWISTART/SC\_TWISTOP) completed (0 to 1 transition of SC\_TWICMDFIN)
- Character transmitted and slave device responded with NACK
- Character transmitted (0 to 1 transition of SC\_TWITXFIN)
- Character received (0 to 1 transition of SC\_TWIRXFIN)
- Received and lost character while receive FIFO was full (receive overrun error)
- Transmitted character while transmit FIFO was empty (transmit underrun error)

To enable CPU interrupts, set the desired interrupt bits in the second-level INT\_SCxCFG register, and enable the top-level SCx interrupt in the NVIC by writing the INT\_SCx bit in the INT\_CFGSET register.

### 8.5.5. Registers

Refer to "8.3.5. Registers" on page 77 (in "8.3. SPI—Master Mode" ) for a description of the SCx\_DATA, SCx\_RATELIN, and SCx\_RATEEXP registers.

**Note:** Substitute "1" or "2" for "x" in the following detailed descriptions.

#### Register 8.10. SCx\_TWISTAT

SC1\_TWISTAT: TWI Status Register

SC2\_TWISTAT: TWI Status Register

<b>Bit</b>	<b>31</b>	<b>30</b>	<b>29</b>	<b>28</b>	<b>27</b>	<b>26</b>	<b>25</b>	<b>24</b>
<b>Name</b>	0	0	0	0	0	0	0	0
<b>Bit</b>	<b>23</b>	<b>22</b>	<b>21</b>	<b>20</b>	<b>19</b>	<b>18</b>	<b>17</b>	<b>16</b>
<b>Name</b>	0	0	0	0	0	0	0	0
<b>Bit</b>	<b>15</b>	<b>14</b>	<b>13</b>	<b>12</b>	<b>11</b>	<b>10</b>	<b>9</b>	<b>8</b>
<b>Name</b>	0	0	0	0	0	0	0	0
<b>Bit</b>	<b>7</b>	<b>6</b>	<b>5</b>	<b>4</b>	<b>3</b>	<b>2</b>	<b>1</b>	<b>0</b>
<b>Name</b>	0	0	0	0	SC_TWICMDFIN	SC_TWIRXFIN	SC_TWITXFIN	SC_TWIRXNAK

SC1\_TWISTAT: Address: 0x4000C844 Reset: 0x0

SC2\_TWISTAT: Address: 0x4000C044 Reset: 0x0

Bitname	Bitfield	Access	Description
SC_TWICMDFIN	[3]	R	This bit is set when a START or STOP command completes. It clears on the next TWI bus activity.
SC_TWIRXFIN	[2]	R	This bit is set when a byte is received. It clears on the next TWI bus activity.
SC_TWITXFIN	[1]	R	This bit is set when a byte is transmitted. It clears on the next TWI bus activity.
SC_TWIRXNAK	[0]	R	This bit is set when a NACK is received from the slave. It clears on the next TWI bus activity.



# EM341

## Register 8.11. SCx\_TWICTRL1

SC1\_TWICTRL1: TWI Control Register 1

SC2\_TWICTRL1: TWI Control Register 1

<b>Bit</b>	31	30	29	28	27	26	25	24
<b>Name</b>	0	0	0	0	0	0	0	0
<b>Bit</b>	23	22	21	20	19	18	17	16
<b>Name</b>	0	0	0	0	0	0	0	0
<b>Bit</b>	15	14	13	12	11	10	9	8
<b>Name</b>	0	0	0	0	0	0	0	0
<b>Bit</b>	7	6	5	4	3	2	1	0
<b>Name</b>	0	0	0	0	SC_TWISTOP	SC_TWISTART	SC_TWISEND	SC_TWIRECV

SC1\_TWICTRL1: Address: 0x4000C84C Reset: 0x0

SC2\_TWICTRL1: Address: 0x4000C04C Reset: 0x0

Bitname	Bitfield	Access	Description
SC_TWISTOP	[3]	RW	Setting this bit sends the STOP command. It clears when the command completes.
SC_TWISTART	[2]	RW	Setting this bit sends the START or repeated START command. It clears when the command completes.
SC_TWISEND	[1]	RW	Setting this bit transmits a byte. It clears when the command completes.
SC_TWIRECV	[0]	RW	Setting this bit receives a byte. It clears when the command completes.

## Register 8.12. SCx\_TWICTRL2

SC1\_TWICTRL2: TWI Control Register 2

SC2\_TWICTRL2: TWI Control Register 2

<b>Bit</b>	31	30	29	28	27	26	25	24
<b>Name</b>	0	0	0	0	0	0	0	0
<b>Bit</b>	23	22	21	20	19	18	17	16
<b>Name</b>	0	0	0	0	0	0	0	0
<b>Bit</b>	15	14	13	12	11	10	9	8
<b>Name</b>	0	0	0	0	0	0	0	0
<b>Bit</b>	7	6	5	4	3	2	1	0
<b>Name</b>	0	0	0	0	0	0	0	SC_TWIACK

SC1\_TWICTRL2: Address: 0x4000C850 Reset: 0x0

SC2\_TWICTRL2: Address: 0x4000C050 Reset: 0x0

Bitname	Bitfield	Access	Description
SC_TWIACK	[0]	RW	Setting this bit signals ACK after a received byte. Clearing this bit signals NACK after a received byte.

## 8.6. UART—Universal Asynchronous Receiver/Transmitter

The SC1 UART is enabled by writing 1 to SC1\_MODE. The SC2 serial controller does not include UART functions.

The UART supports the following features:

- Flexible baud rate clock (300 bps to 921.6 kbps)
- Data bits (7 or 8)
- Parity bits (none, odd, or even)
- Stop bits (1 or 2)
- False start bit and noise filtering
- Receive and transmit FIFOs
- Optional RTS/CTS flow control
- Receive and transmit DMA channels

### 8.6.1. GPIO Usage

The UART uses two signals to transmit and receive serial data:

- TXD (Transmitted Data) - serial data sent by the EM341
- RXD (Received Data) - serial data received by the EM341

If RTS/CTS flow control is enabled, these two signals are also used:

- nRTS (Request To Send) - indicates the EM341 is able to receive data
- nCTS (Clear To Send) - inhibits sending data from the EM341 if not asserted

The GPIO pins assigned to these signals are shown in Table 8.10.

**Table 8.10. UART GPIO Usage**

	TXD	RXD	nCTS <sup>1</sup>	nRTS*
<b>Direction</b>	Output	Input	Input	Output
<b>GPIO Configuration</b>	Alternate Output (push-pull)	Input	Input	Alternate Output (push-pull)
<b>SC1 pin</b>	PB1	PB2	PB3	PB4
<b>*Note:</b> Only used if RTS/CTS hardware flow control is enabled.				

## 8.6.2. Set Up and Configuration

The UART baud rate clock is produced by a programmable baud generator starting from the 24 Hz clock:

$$\text{baud} = \frac{24 \text{ MHz}}{2N + F}$$

The integer portion of the divisor, N, is written to the SC1\_UARTPER register and the fractional part, F, to the SC1\_UARTFRAC register. Table 8.11 shows the values used to generate some common baud rates and their associated clock frequency error. The UART requires an internal clock that is at least eight times the baud rate clock, so the minimum allowable setting for SC1\_UARTPER is 8.

**Table 8.11. UART Baud Rate Divisors for Common Baud Rates**

Baud Rate (bits/sec)	SC1_UARTPER	SC1_UARTFRAC	Baud Rate Error (%)
300	40000	0	0
2400	5000	0	0
4800	2500	0	0
9600	1250	0	0
19200	625	0	0
38400	312	1	0
57600	208	1	-0.08
115200	104	0	+0.16
230400	52	0	+0.16
460800	26	0	+0.16
921600	13	0	+0.16

The UART can miss bytes when the inter-byte gap is long or there is a baud rate mismatch between receiver and transmitter. The UART may detect a parity and/or framing error on the corrupted byte, but there will not necessarily be any error detected.

The UART is best operated in systems where the other side of the communication link also uses a crystal as its timing reference, and baud rates should be selected to minimize the baud rate mismatch to the crystal tolerance. Additionally, UART protocols should contain some form of error checking (for example CRC) at the packet level to detect, and retry in the event of errors. Since the probability of corruption is low, there would only be a small effect on UART throughput due to retries.

Errors may occur when:

$$T_{\text{gap}} \geq \frac{10^6}{\text{baud} \times \text{Error}}$$

Where:

$T_{\text{gap}}$  = inter-byte gap in seconds

baud = baud rate in bps

Error = relative frequency error in ppm

For example, if the baud rate tolerance between receive and transmit is 200 ppm (reasonable if both sides are derived from a crystal), and the baud rate is 115200 bps, then errors will not occur until the inter-byte gap exceeds 43 ms. If the gap is exceeded then the chance of an error is essentially random, with a probability of approximately  $P = \text{baud} / 24e6$ . At 115200 bps, the probability of corruption is 0.5%.

The UART character frame format is determined by four bits in the SC1\_UARTCFG register:

- SC\_UART8BIT specifies the number of data bits in received and transmitted characters. If this bit is clear, characters have 7 data bits; if set, characters have 8 data bits.
- SC\_UART2STP selects the number of stop bits in transmitted characters. (Only one stop bit is required in received characters.) If this bit is clear, characters are transmitted with one stop bit; if set, characters are transmitted with two stop bits.
- SC\_UARTPAR controls whether or not received and transmitted characters include a parity bit. If SC\_UARTPAR is clear, characters do not contain a parity bit, otherwise, characters do contain a parity bit.
- SC\_UARTODD specifies whether transmitted and received parity bits contain odd or even parity. If this bit is clear, the parity bit is even, and if set, the parity bit is odd. Even parity is the exclusive-or of all of the data bits, and odd parity is the inverse of the even parity value. SC\_UARTODD has no effect if SC\_UARTPAR is clear.

A UART character frame contains, in sequence:

- The start bit
- The least significant data bit
- The remaining data bits
- If parity is enabled, the parity bit
- The stop bit, or bits, if 2 stop bits are selected.

Figure 8.3 shows the UART character frame format, with optional bits indicated. Depending on the options chosen for the character frame, the length of a character frame ranges from 9 to 12 bit times.

Note that asynchronous serial data may have arbitrarily long idle periods between characters. When idle, serial data (TXD or RXD) is held in the high state. Serial data transitions to the low state in the start bit at the beginning of a character frame.

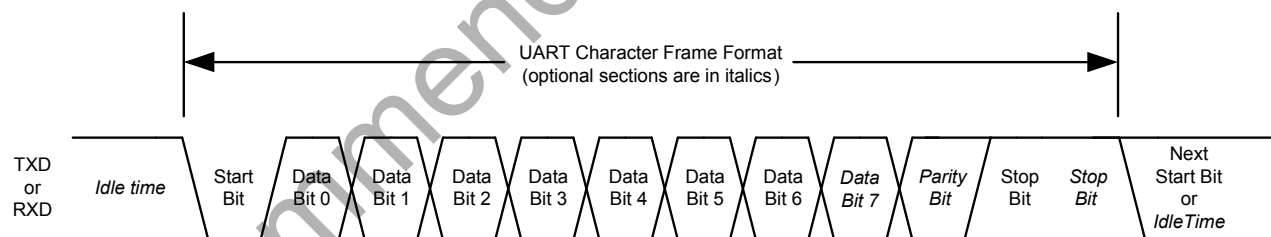

**Figure 8.3. UART Character Frame Format**

## 8.6.3. FIFOs

Characters transmitted and received by the UART are buffered in the transmit and receive FIFOs that are both 4 entries deep (see Figure 8.4). When software writes a character to the SC1\_DATA register, it is pushed onto the transmit FIFO. Similarly, when software reads from the SC1\_DATA register, the character returned is pulled from the receive FIFO. If the transmit and receive DMA channels are used, the DMA channels also write to and read from the transmit and receive FIFOs.

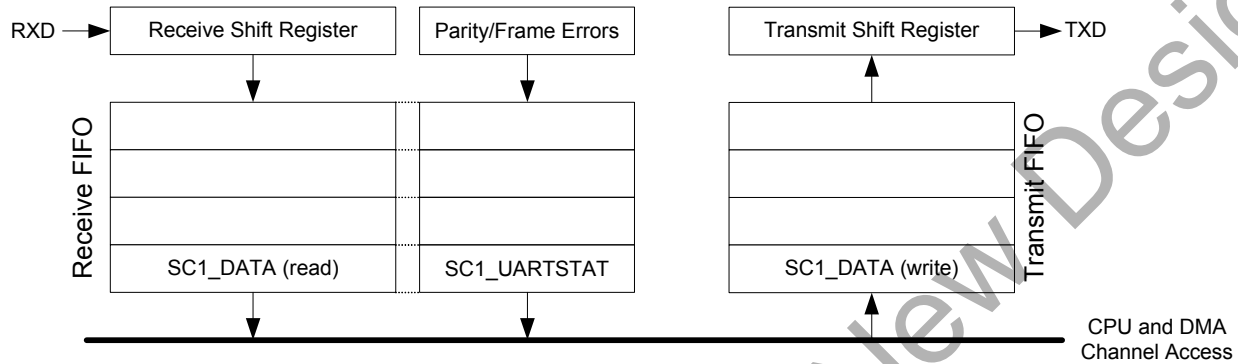

**Figure 8.4. UART FIFOs**

## 8.6.4. RTS/CTS Flow control

RTS/CTS flow control, also called hardware flow control, uses two signals (nRTS and nCTS) in addition to received and transmitted data (see Figure 8.5). Flow control is used by a data receiver to prevent buffer overflow, by signaling an external device when it is and is not allowed to transmit.

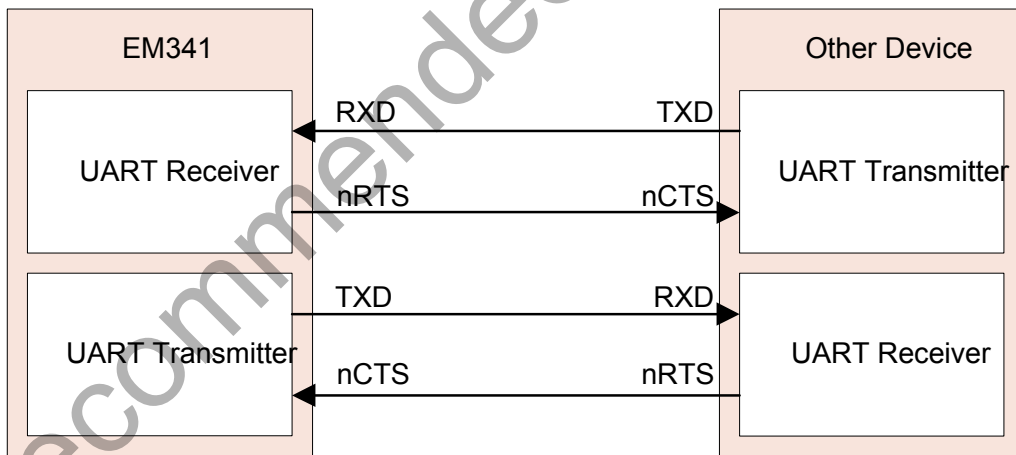

**Figure 8.5. RTS/CTS Flow Control Connections**

The UART RTS/CTS flow control options are selected by the SC\_UARTFLOW and SC\_URTAUTO bits in the SC1\_UARTCFG register (see Table 8.12). Whenever the SC\_UARTFLOW bit is set, the UART will not start transmitting a character unless nCTS is low (asserted). If nCTS transitions to the high state (deasserts) while a character is being transmitted, transmission of that character continues until it is complete.

If the SC\_URTAUTO bit is set, nRTS is controlled automatically by hardware: nRTS is put into the low state (asserted) when the receive FIFO has room for at least two characters, otherwise is it in the high state (unasserted). If SC\_URTAUTO is clear, software controls the nRTS output by setting or clearing the SC\_UARTRTS bit in the SC1\_UARTCFG register. Software control of nRTS is useful if the external serial device cannot stop transmitting characters promptly when nRTS is set to the high state (deasserted).

Table 8.12. UART RTS/CTS Flow Control Configurations

SC1_UARTCFG			Pins Used	Operating Mode
SC_UARTxxx*				
FLOW	AUTO	RTS		
0	—	—	TXD, RXD	No RTS/CTS flow control
1	0	0/1	TXD, RXD, nCTS, nRTS	Flow control using RTS/CTS with software control of nRTS: nRTS controlled by SC_UARTRTS bit in SC1_UARTCFG register
1	1	—	TXD, RXD, nCTS, nRTS	Flow control using RTS/CTS with hardware control of nRTS: nRTS is asserted if room for at least 2 characters in receive FIFO

\*Note: The notation “xxx” means that the corresponding column header below is inserted to form the field name.

### 8.6.5. DMA

"8.7. DMA Channels" on page 99 describes how to configure and use the serial receive and transmit DMA channels.

The receive DMA channel has special provisions to record UART receive errors. When the DMA channel transfers a character from the receive FIFO to a buffer in memory, it checks the stored parity and frame error status flags. When an error is flagged, the SC1\_RXERRA/B register is updated, marking the offset to the first received character with a parity or frame error. Similarly if a receive overrun error occurs, the SC1\_RXERRA/B registers mark the error offset. The receive FIFO hardware generates the INT\_SCRXOVF interrupt and DMA status register indicates the error immediately, but in this case the error offset is 4 characters ahead of the actual overflow at the input to the receive FIFO. Two conditions will clear the error indication: setting the appropriate SC\_RXDMARST bit in the SC1\_DMACTRL register, or loading the appropriate DMA buffer after it has unloaded.

### 8.6.6. Interrupts

UART interrupts are generated on the following events:

- Transmit FIFO empty and last character shifted out (depending on SCx\_INTMODE, either the 0 to 1 transition or the high level of SC\_UARTTXIDLE)
- Transmit FIFO changed from full to not full (depending on SCx\_INTMODE, either the 0 to 1 transition or the high level of SC\_UARTTXFREE)
- Receive FIFO changed from empty to not empty (depending on SCx\_INTMODE, either the 0 to 1 transition or the high level of SC\_UARTRXVAL)
- Transmit DMA buffer A/B complete (1 to 0 transition of SC\_TXACTA/B)
- Receive DMA buffer A/B complete (1 to 0 transition of SC\_RXACTA/B)
- Character received with parity error
- Character received with frame error
- Character received and lost when receive FIFO was full (receive overrun error)

To enable CPU interrupts, set the desired interrupt bits in the second-level INT\_SCxCFG register, and enable the top-level SCx interrupt in the NVIC by writing the INT\_SCx bit in the INT\_CFGSET register.

# EM341

## 8.6.7. Registers

Refer to "8.3.5. Registers" on page 77 (in "8.3. SPI—Master Mode" ) for a description of the SCx\_DATA register.

**Register 8.13. SC1\_UARTSTAT: UART Status Register**

<b>Bit</b>	<b>31</b>	<b>30</b>	<b>29</b>	<b>28</b>	<b>27</b>	<b>26</b>	<b>25</b>	<b>24</b>
<b>Name</b>	0	0	0	0	0	0	0	0
<b>Bit</b>	<b>23</b>	<b>22</b>	<b>21</b>	<b>20</b>	<b>19</b>	<b>18</b>	<b>17</b>	<b>16</b>
<b>Name</b>	0	0	0	0	0	0	0	0
<b>Bit</b>	<b>15</b>	<b>14</b>	<b>13</b>	<b>12</b>	<b>11</b>	<b>10</b>	<b>9</b>	<b>8</b>
<b>Name</b>	0	0	0	0	0	0	0	0
<b>Bit</b>	<b>7</b>	<b>6</b>	<b>5</b>	<b>4</b>	<b>3</b>	<b>2</b>	<b>1</b>	<b>0</b>
<b>Name</b>	0	SC_ UARTTXIDLE	SC_ UARTPARERR	SC_ UARTFRMERR	SC_ UARTRXOVF	SC_ UARTTXFREE	SC_ UARTRXVAL	SC_ UARTCTS

SC1\_UARTSTAT: Address: 0x4000C848 Reset: 0x40

Bitname	Bitfield	Access	Description
SC_UARTTXIDLE	[6]	R	This bit is set when both the transmit FIFO and the transmit serializer are empty.
SC_UARTPARERR	[5]	R	This bit is set when the byte in the data register was received with a parity error. This bit is updated when the data register is read, and is cleared if the receive FIFO is empty.
SC_UARTFRMERR	[4]	R	This bit is set when the byte in the data register was received with a frame error. This bit is updated when the data register is read, and is cleared if the receive FIFO is empty.
SC_UARTRXOVF	[3]	R	This bit is set when the receive FIFO has been overrun. This occurs if a byte is received when the receive FIFO is full. This bit is cleared by reading the data register.
SC_UARTTXFREE	[2]	R	This bit is set when the transmit FIFO has space for at least one byte.
SC_UARTRXVAL	[1]	R	This bit is set when the receive FIFO contains at least one byte.
SC_UARTCTS	[0]	R	This bit shows the logical state (not voltage level) of the nCTS input: 0: nCTS is deasserted (pin is high, 'XOFF', RS232 negative voltage); the UART is inhibited from starting to transmit a byte. 1: nCTS is asserted (pin is low, 'XON', RS232 positive voltage); the UART may transmit.

**Register 8.14. SC1\_UARTCFG: UART Configuration Register**

<b>Bit</b>	<b>31</b>	<b>30</b>	<b>29</b>	<b>28</b>	<b>27</b>	<b>26</b>	<b>25</b>	<b>24</b>
<b>Name</b>	0	0	0	0	0	0	0	0
<b>Bit</b>	23	22	21	20	19	18	17	16
<b>Name</b>	0	0	0	0	0	0	0	0
<b>Bit</b>	15	14	13	12	11	10	9	8
<b>Name</b>	0	0	0	0	0	0	0	0
<b>Bit</b>	7	6	5	4	3	2	1	0
<b>Name</b>	0	SC_ UARTAUTO	SC_ UARTFLOW	SC_ UARTODD	SC_ UARTPAR	SC_ UART2STP	SC_ UART8BIT	SC_ UARTRTS

SC1\_UARTCFG: Address: 0x4000C85C Reset: 0x0

Bitname	Bitfield	Access	Description
SC_UARTAUTO	[6]	RW	Set this bit to enable automatic nRTS control by hardware (SC_UARTFLOW must also be set). When automatic control is enabled, nRTS will be deasserted when the receive FIFO has space for only one more byte (inhibits transmission from the other device) and will be asserted if it has space for more than one byte (enables transmission from the other device). The SC_UARTRTS bit in this register has no effect if this bit is set.
SC_UARTFLOW	[5]	RW	Set this bit to enable using nRTS/nCTS flow control signals. Clear this bit to disable the signals. When this bit is clear, the UART transmitter will not be inhibited by nCTS.
SC_UARTODD	[4]	RW	If parity is enabled, specifies the kind of parity. 0: Even parity. 1: Odd parity.
SC_UARTPAR	[3]	RW	Specifies whether to use parity bits. 0: Don't use parity. 1: Use parity.
SC_UART2STP	[2]	RW	Number of stop bits transmitted. 0: 1 stop bit. 1: 2 stop bits.
SC_UART8BIT	[1]	RW	Number of data bits. 0: 7 data bits. 1: 8 data bits.
SC_UARTRTS	[0]	RW	nRTS is an output to control the flow of serial data sent to the EM341 from another device. This bit directly controls the output at the nRTS pin (SC_UARTFLOW must be set and SC_UARTAUTO must be cleared). When this bit is set, nRTS is asserted (pin is low, 'XON', RS232 positive voltage); the other device's transmission is enabled. When this bit is cleared, nRTS is deasserted (pin is high, 'XOFF', RS232 negative voltage), the other device's transmission is inhibited.



# EM341

**Register 8.15. SC1\_UARTPER: UART Baud Rate Period Register**

Bit	31	30	29	28	27	26	25	24
Name	0	0	0	0	0	0	0	0
Bit	23	22	21	20	19	18	17	16
Name	0	0	0	0	0	0	0	0
Bit	15	14	13	12	11	10	9	8
Name	SC_UARTPER							
Bit	7	6	5	4	3	2	1	0
Name	SC_UARTPER							

SC1\_UARTPER: Address: 0x4000C868 Reset: 0x0

Bitname	Bitfield	Access	Description
SC_UARTPER	[15:0]	RW	The integer part of baud rate period (N) in the equation: $\text{rate} = \frac{24 \text{ MHz}}{((2 \times N) + F)}$

**Register 8.16. SC1\_UARTFRAC: UART Baud Rate Fractional Period Register**

Bit	31	30	29	28	27	26	25	24
Name	0	0	0	0	0	0	0	0
Bit	23	22	21	20	19	18	17	16
Name	0	0	0	0	0	0	0	0
Bit	15	14	13	12	11	10	9	8
Name	0	0	0	0	0	0	0	0
Bit	7	6	5	4	3	2	1	0
Name	0	0	0	0	0	0	0	SC_UARTFRAC

SC1\_UARTFRAC: Address: 0x4000C86C Reset: 0x0

Bitname	Bitfield	Access	Description
SC_UARTFRAC	[0]	RW	The fractional part of the baud rate period (F) in the equation: $\text{rate} = \frac{24 \text{ MHz}}{((2 \times N) + F)}$

## 8.7. DMA Channels

The EM341 serial DMA channels enable efficient, high-speed operation of the SPI and UART controllers by reducing the load on the CPU as well as decreasing the frequency of interrupts that it must service. The transmit and receive DMA channels can transfer data between the transmit and receive FIFOs and the DMA buffers in main memory as quickly as it can be transmitted or received. Once software defines, configures, and activates the DMA, it only needs to handle an interrupt when a transmit buffer has been emptied or a receive buffer has been filled. The DMA channels each support two memory buffers, labeled A and B, and can alternate ("ping-pong") between them automatically to allow continuous communication without critical interrupt timing.

**Note:** DMA memory buffer terminology

- load - make a buffer available for the DMA channel to use
- pending - a buffer loaded but not yet active
- active - the buffer that will be used for the next DMA transfer
- unload - DMA channel action when it has finished with a buffer
- idle - a buffer that has not been loaded, or has been unloaded

To use a DMA channel, software should follow these steps:

1. Reset the DMA channel by setting the SC\_TXDMARST (or SC\_RXDMARST) bit in the SCx\_DMACTRL register.
2. Set up the DMA buffers. The two DMA buffers, A and B, are defined by writing the start address to SCx\_TXBEGA/B (or SCx\_RXBEGA/B) and the (inclusive) end address to SCx\_TXENDA/B (or SCx\_RXENDA/B). Note that DMA buffers must be in RAM.
3. Configure and initialize SCx for the desired operating mode.
4. Enable second-level interrupts triggered when DMA buffers unload by setting the INT\_SCTXULDA/B (or INT\_SCRXULDA/B) bits in the INT\_SCXFLAG register.
5. Enable top-level NVIC interrupts by setting the INT\_SCx bit in the INT\_CFGSET register.
6. Start the DMA by loading the DMA buffers by setting the SC\_TXLODA/B (or SC\_RXLODA/B) bits in the SCx\_DMACTRL register.

A DMA buffer's end address, SCx\_TXENDA/B (or SCx\_RXENDA/B), can be written while the buffer is loaded or active. This is useful for receiving messages that contain an initial byte count, since it allows software to set the buffer end address at the last byte of the message.

As the DMA channel transfers data between the transmit or receive FIFO and a memory buffer, the DMA count register contains the byte offset from the start of the buffer to the address of the next byte that will be written or read. A transmit DMA channel has a single DMA count register (SCx\_TXCNT) that applies to whichever transmit buffer is active, but a receive DMA channel has two DMA count registers (SCx\_RXCNTA/B), one for each receive buffer. The DMA count register contents are preserved until the corresponding buffer, or either buffer in the case of the transmit DMA count, is loaded, or until the DMA is reset.

The receive DMA count register may be written while the corresponding buffer is loaded. If the buffer is not loaded, writing the DMA count register also loads the buffer while preserving the count value written. This feature can simplify handling UART receive errors.

The DMA channel stops using a buffer and unloads it when the following is true:

$(\text{DMA buffer start address} + \text{DMA buffer count}) > \text{DMA buffer end address}$

Typically a transmit buffer is unloaded after all its data has been sent, and a receive buffer is unloaded after it is filled with data, but writing to the buffer end address or buffer count registers can also cause a buffer to unload early.

Serial controller DMA channels include additional features specific to the SPI and UART operation and are described in those sections.

# EM341

## 8.7.1. Registers

**Note:** Substitute “1” or “2” for “x” in the following detailed descriptions.

### Register 8.17. SCx\_DMACTRL

**SC1\_DMACTRL: Serial DMA Control Register**

**SC2\_DMACTRL: Serial DMA Control Register**

<b>Bit</b>	<b>31</b>	<b>30</b>	<b>29</b>	<b>28</b>	<b>27</b>	<b>26</b>	<b>25</b>	<b>24</b>
<b>Name</b>	0	0	0	0	0	0	0	0
<b>Bit</b>	<b>23</b>	<b>22</b>	<b>21</b>	<b>20</b>	<b>19</b>	<b>18</b>	<b>17</b>	<b>16</b>
<b>Name</b>	0	0	0	0	0	0	0	0
<b>Bit</b>	<b>15</b>	<b>14</b>	<b>13</b>	<b>12</b>	<b>11</b>	<b>10</b>	<b>9</b>	<b>8</b>
<b>Name</b>	0	0	0	0	0	0	0	0
<b>Bit</b>	<b>7</b>	<b>6</b>	<b>5</b>	<b>4</b>	<b>3</b>	<b>2</b>	<b>1</b>	<b>0</b>
<b>Name</b>	0	0	SC_TXDMARST	SC_RXDMARST	SC_TXLODB	SC_TXLODA	SC_RXLODB	SC_RXLODA

SC1\_DMACTRL: Address: 0x4000C830 Reset: 0x0

SC2\_DMACTRL: Address: 0x4000C030 Reset: 0x0

Bitname	Bitfield	Access	Description
SC_TXDMARST	[5]	W	Setting this bit resets the transmit DMA. The bit clears automatically.
SC_RXDMARST	[4]	W	Setting this bit resets the receive DMA. The bit clears automatically.
SC_TXLODB	[3]	RW	Setting this bit loads DMA transmit buffer B addresses and allows the DMA controller to start processing transmit buffer B. If both buffer A and B are loaded simultaneously, buffer A will be used first. This bit is cleared when DMA completes. Writing a zero to this bit has no effect. Reading this bit returns DMA buffer status: 0: DMA processing is complete or idle. 1: DMA processing is active or pending.
SC_TXLODA	[2]	RW	Setting this bit loads DMA transmit buffer A addresses and allows the DMA controller to start processing transmit buffer A. If both buffer A and B are loaded simultaneously, buffer A will be used first. This bit is cleared when DMA completes. Writing a zero to this bit has no effect. Reading this bit returns DMA buffer status: 0: DMA processing is complete or idle. 1: DMA processing is active or pending.
SC_RXLODB	[1]	RW	Setting this bit loads DMA receive buffer B addresses and allows the DMA controller to start processing receive buffer B. If both buffer A and B are loaded simultaneously, buffer A will be used first. This bit is cleared when DMA completes. Writing a zero to this bit has no effect. Reading this bit returns DMA buffer status: 0: DMA processing is complete or idle. 1: DMA processing is active or pending.
SC_RXLODA	[0]	RW	Setting this bit loads DMA receive buffer A addresses and allows the DMA controller to start processing receive buffer A. If both buffer A and B are loaded simultaneously, buffer A will be used first. This bit is cleared when DMA completes. Writing a zero to this bit has no effect. Reading this bit returns DMA buffer status: 0: DMA processing is complete or idle. 1: DMA processing is active or pending.

**Register 8.18. SCx\_DMASTAT****SC1\_DMASTAT: Serial DMA Status Register****SC2\_DMASTAT: Serial DMA Status Register**

Bit	31	30	29	28	27	26	25	24
Name	0	0	0	0	0	0	0	0
Bit	23	22	21	20	19	18	17	16
Name	0	0	0	0	0	0	0	0
Bit	15	14	13	12	11	10	9	8
Name	0	0	0	SC_RXSSEL			SC_RXFRMB	SC_RXFRMA
Bit	7	6	5	4	3	2	1	0
Name	SC_RXPARB	SC_RXPARA	SC_RXOVFB	SC_RXOVFA	SC_TXACTB	SC_TXACTA	SC_RXACTB	SC_RXACTA

SC1\_DMASTAT: Address: 0x4000C82C Reset: 0x0

SC2\_DMASTAT: Address: 0x4000C02C Reset: 0x0

Bitname	Bitfield	Access	Description
SC_RXSSEL	[12:10]	R	Status of the receive count saved in SCx_RXCNTSAVED (SPI slave mode) when nSSEL deasserts. Cleared when a receive buffer is loaded and when the receive DMA is reset. 0: No count was saved because nSSEL did not deassert. 2: Buffer A's count was saved, nSSEL deasserted once. 3: Buffer B's count was saved, nSSEL deasserted once. 6: Buffer A's count was saved, nSSEL deasserted more than once. 7: Buffer B's count was saved, nSSEL deasserted more than once. 1, 4, 5: Reserved.
SC_RXFRMB	[9]	R	This bit is set when DMA receive buffer B reads a byte with a frame error from the receive FIFO. It is cleared the next time buffer B is loaded or when the receive DMA is reset. (SC1 in UART mode only)
SC_RXFRMA	[8]	R	This bit is set when DMA receive buffer A reads a byte with a frame error from the receive FIFO. It is cleared the next time buffer A is loaded or when the receive DMA is reset. (SC1 in UART mode only)
SC_RXPARB	[7]	R	This bit is set when DMA receive buffer B reads a byte with a parity error from the receive FIFO. It is cleared the next time buffer B is loaded or when the receive DMA is reset. (SC1 in UART mode only)
SC_RXPARA	[6]	R	This bit is set when DMA receive buffer A reads a byte with a parity error from the receive FIFO. It is cleared the next time buffer A is loaded or when the receive DMA is reset. (SC1 in UART mode only)
SC_RXOVFB	[5]	R	This bit is set when DMA receive buffer B was passed an overrun error from the receive FIFO. Neither receive buffer was capable of accepting any more bytes (unloaded), and the FIFO filled up. Buffer B was the next buffer to load, and when it drained the FIFO the overrun error was passed up to the DMA and flagged with this bit. Cleared the next time buffer B is loaded and when the receive DMA is reset.

# EM341

SC_RXOVFA	[4]	R	This bit is set when DMA receive buffer A was passed an overrun error from the receive FIFO. Neither receive buffer was capable of accepting any more bytes (unloaded), and the FIFO filled up. Buffer A was the next buffer to load, and when it drained the FIFO the overrun error was passed up to the DMA and flagged with this bit. Cleared the next time buffer A is loaded and when the receive DMA is reset.
SC_TXACTB	[3]	R	This bit is set when DMA transmit buffer B is active.
SC_TXACTA	[2]	R	This bit is set when DMA transmit buffer A is active.
SC_RXACTB	[1]	R	This bit is set when DMA receive buffer B is active.
SC_RXACTA	[0]	R	This bit is set when DMA receive buffer A is active.

## Register 8.19. SCx\_TXBEGA

SC1\_TXBEGA: Transmit DMA Begin Address Register A

SC2\_TXBEGA: Transmit DMA Begin Address Register A

<b>Bit</b>	<b>31</b>	<b>30</b>	<b>29</b>	<b>28</b>	<b>27</b>	<b>26</b>	<b>25</b>	<b>24</b>
<b>Name</b>	0	0	1	0	0	0	0	0
<b>Bit</b>	<b>23</b>	<b>22</b>	<b>21</b>	<b>20</b>	<b>19</b>	<b>18</b>	<b>17</b>	<b>16</b>
<b>Name</b>	0	0	0	0	0	0	0	0
<b>Bit</b>	<b>15</b>	<b>14</b>	<b>13</b>	<b>12</b>	<b>11</b>	<b>10</b>	<b>9</b>	<b>8</b>
<b>Name</b>	0	0	SC_TXBEGA					
<b>Bit</b>	<b>7</b>	<b>6</b>	<b>5</b>	<b>4</b>	<b>3</b>	<b>2</b>	<b>1</b>	<b>0</b>
<b>Name</b>	SC_TXBEGA							

SC1\_TXBEGA: Address: 0x4000C810 Reset: 0x20000000

SC2\_TXBEGA: Address: 0x4000C010 Reset: 0x20000000

Bitname	Bitfield	Access	Description
SC_TXBEGA	[13:0]	RW	DMA transmit buffer A start address.

**Register 8.20. SCx\_TXBEGB****SC1\_TXBEGB: Transmit DMA Begin Address Register B****SC2\_TXBEGB: Transmit DMA Begin Address Register B**

<b>Bit</b>	<b>31</b>	<b>30</b>	<b>29</b>	<b>28</b>	<b>27</b>	<b>26</b>	<b>25</b>	<b>24</b>
<b>Name</b>	0	0	1	0	0	0	0	0
<b>Bit</b>	<b>23</b>	<b>22</b>	<b>21</b>	<b>20</b>	<b>19</b>	<b>18</b>	<b>17</b>	<b>16</b>
<b>Name</b>	0	0	0	0	0	0	0	0
<b>Bit</b>	<b>15</b>	<b>14</b>	<b>13</b>	<b>12</b>	<b>11</b>	<b>10</b>	<b>9</b>	<b>8</b>
<b>Name</b>	0	0	SC_TXBEGB					
<b>Bit</b>	<b>7</b>	<b>6</b>	<b>5</b>	<b>4</b>	<b>3</b>	<b>2</b>	<b>1</b>	<b>0</b>
<b>Name</b>	SC_TXBEGB							

SC1\_TXBEGB: Transmit DMA Begin Address Register B

SC2\_TXBEGB: Transmit DMA Begin Address Register B

<b>Bitname</b>	<b>Bitfield</b>	<b>Access</b>	<b>Description</b>
SC_TXBEGB	[13:0]	RW	DMA transmit buffer B start address.

**Register 8.21. SCx\_TXENDA****SC1\_TXENDA: Transmit DMA End Address Register A****SC2\_TXENDA: Transmit DMA End Address Register A**

<b>Bit</b>	<b>31</b>	<b>30</b>	<b>29</b>	<b>28</b>	<b>27</b>	<b>26</b>	<b>25</b>	<b>24</b>
<b>Name</b>	0	0	1	0	0	0	0	0
<b>Bit</b>	<b>23</b>	<b>22</b>	<b>21</b>	<b>20</b>	<b>19</b>	<b>18</b>	<b>17</b>	<b>16</b>
<b>Name</b>	0	0	0	0	0	0	0	0
<b>Bit</b>	<b>15</b>	<b>14</b>	<b>13</b>	<b>12</b>	<b>11</b>	<b>10</b>	<b>9</b>	<b>8</b>
<b>Name</b>	0	0	SC_TXENDA					
<b>Bit</b>	<b>7</b>	<b>6</b>	<b>5</b>	<b>4</b>	<b>3</b>	<b>2</b>	<b>1</b>	<b>0</b>
<b>Name</b>	SC_TXENDA							

SC1\_TXENDA: Address: 0x4000C814 Reset: 0x20000000

SC2\_TXENDA: Address: 0x4000C014 Reset: 0x20000000

<b>Bitname</b>	<b>Bitfield</b>	<b>Access</b>	<b>Description</b>
SC_TXENDA	[13:0]	RW	Address of the last byte that will be read from the DMA transmit buffer A.

# EM341

## Register 8.22. SCx\_TXENDB

SC1\_TXENDB: Transmit DMA End Address Register B

SC2\_TXENDB: Transmit DMA End Address Register B

Bit	31	30	29	28	27	26	25	24
Name	0	0	1	0	0	0	0	0
Bit	23	22	21	20	19	18	17	16
Name	0	0	0	0	0	0	0	0
Bit	15	14	13	12	11	10	9	8
Name	0	0	SC_TXENDB					
Bit	7	6	5	4	3	2	1	0
Name	SC_TXENDB							

SC1\_TXENDB: Address: 0x4000C81C Reset: 0x20000000

SC2\_TXENDB: Address: 0x4000C01C Reset: 0x20000000

Bitname	Bitfield	Access	Description
SC_TXENDB	[13:0]	RW	Address of the last byte that will be read from the DMA transmit buffer B.

## Register 8.23. SCx\_TXCNT

SC1\_TXCNT: Transmit DMA Count Register

SC2\_TXCNT: Transmit DMA Count Register

Bit	31	30	29	28	27	26	25	24
Name	0	0	0	0	0	0	0	0
Bit	23	22	21	20	19	18	17	16
Name	0	0	0	0	0	0	0	0
Bit	15	14	13	12	11	10	9	8
Name	0	0	SC_TXCNT					
Bit	7	6	5	4	3	2	1	0
Name	SC_TXCNT							

SC1\_TXCNT: Address: 0x4000C828 Reset: 0x0

SC2\_TXCNT: Address: 0x4000C028 Reset: 0x0

Bitname	Bitfield	Access	Description
SC_TXCNT	[13:0]	R	The offset from the start of the active DMA transmit buffer from which the next byte will be read. This register is set to zero when the buffer is loaded and when the DMA is reset.

**Register 8.24. SCx\_RXBEGA****SC1\_RXBEGA: Receive DMA Begin Address Register A****SC2\_RXBEGA: Receive DMA Begin Address Register A**

<b>Bit</b>	<b>31</b>	<b>30</b>	<b>29</b>	<b>28</b>	<b>27</b>	<b>26</b>	<b>25</b>	<b>24</b>
<b>Name</b>	0	0	1	0	0	0	0	0
<b>Bit</b>	<b>23</b>	<b>22</b>	<b>21</b>	<b>20</b>	<b>19</b>	<b>18</b>	<b>17</b>	<b>16</b>
<b>Name</b>	0	0	0	0	0	0	0	0
<b>Bit</b>	<b>15</b>	<b>14</b>	<b>13</b>	<b>12</b>	<b>11</b>	<b>10</b>	<b>9</b>	<b>8</b>
<b>Name</b>	0	0	SC_RXBEGA					
<b>Bit</b>	<b>7</b>	<b>6</b>	<b>5</b>	<b>4</b>	<b>3</b>	<b>2</b>	<b>1</b>	<b>0</b>
<b>Name</b>	SC_RXBEGA							

SC1\_RXBEGA: Address: 0x4000C800 Reset: 0x20000000

SC2\_RXBEGA: Address: 0x4000C000 Reset: 0x20000000

<b>Bitname</b>	<b>Bitfield</b>	<b>Access</b>	<b>Description</b>
SC_RXBEGA	[13:0]	RW	DMA receive buffer A start address.

**Register 8.25. SCx\_RXBEGB****SC1\_RXBEGB: Receive DMA Begin Address Register B****SC2\_RXBEGB: Receive DMA Begin Address Register B**

<b>Bit</b>	<b>31</b>	<b>30</b>	<b>29</b>	<b>28</b>	<b>27</b>	<b>26</b>	<b>25</b>	<b>24</b>
<b>Name</b>	0	0	1	0	0	0	0	0
<b>Bit</b>	<b>23</b>	<b>22</b>	<b>21</b>	<b>20</b>	<b>19</b>	<b>18</b>	<b>17</b>	<b>16</b>
<b>Name</b>	0	0	0	0	0	0	0	0
<b>Bit</b>	<b>15</b>	<b>14</b>	<b>13</b>	<b>12</b>	<b>11</b>	<b>10</b>	<b>9</b>	<b>8</b>
<b>Name</b>	0	0	SC_RXBEGB					
<b>Bit</b>	<b>7</b>	<b>6</b>	<b>5</b>	<b>4</b>	<b>3</b>	<b>2</b>	<b>1</b>	<b>0</b>
<b>Name</b>	SC_RXBEGB							

SC1\_RXBEGB: Address: 0x4000C808 Reset: 0x20000000

SC2\_RXBEGB: Address: 0x4000C008 Reset: 0x20000000



# EM341

Bitname	Bitfield	Access	Description
SC_RXBEGB	[13:0]	RW	DMA receive buffer B start address.

## Register 8.26. SCx\_RXENDA

SC1\_RXENDA: Receive DMA End Address Register A

SC2\_RXENDA: Receive DMA End Address Register A

Bit	31	30	29	28	27	26	25	24	
Name	0	0	1	0	0	0	0	0	
Bit	23	22	21	20	19	18	17	16	
Name	0	0	0	0	0	0	0	0	
Bit	15	14	13	12	11	10	9	8	
Name	0	0	SC_RXENDA						
Bit	7	6	5	4	3	2	1	0	
Name	SC_RXENDA								

SC1\_RXENDA: Address: 0x4000C804 Reset: 0x20000000

SC2\_RXENDA: Address: 0x4000C004 Reset: 0x20000000

Bitname	Bitfield	Access	Description
SC_RXENDA	[13:0]	RW	Address of the last byte that will be written in the DMA receive buffer A.

**Register 8.27. SCx\_RXENDB****SC1\_RXENDB: Receive DMA End Address Register B****SC2\_RXENDB: Receive DMA End Address Register B**

<b>Bit</b>	<b>31</b>	<b>30</b>	<b>29</b>	<b>28</b>	<b>27</b>	<b>26</b>	<b>25</b>	<b>24</b>
<b>Name</b>	0	0	1	0	0	0	0	0
<b>Bit</b>	<b>23</b>	<b>22</b>	<b>21</b>	<b>20</b>	<b>19</b>	<b>18</b>	<b>17</b>	<b>16</b>
<b>Name</b>	0	0	0	0	0	0	0	0
<b>Bit</b>	<b>15</b>	<b>14</b>	<b>13</b>	<b>12</b>	<b>11</b>	<b>10</b>	<b>9</b>	<b>8</b>
<b>Name</b>	0	0	SC_RXENDB					
<b>Bit</b>	<b>7</b>	<b>6</b>	<b>5</b>	<b>4</b>	<b>3</b>	<b>2</b>	<b>1</b>	<b>0</b>
<b>Name</b>	SC_RXENDB							

SC1\_RXENDB: Address: 0x4000C80C Reset: 0x20000000

SC2\_RXENDB: Address: 0x4000C00C Reset: 0x20000000

<b>Bitname</b>	<b>Bitfield</b>	<b>Access</b>	<b>Description</b>
SC_RXENDB	[13:0]	RW	Address of the last byte that will be written in the DMA receive buffer B.

# EM341

## Register 8.28. SCx\_RXCNTA

SC1\_RXCNTA: Receive DMA Count Register A

SC2\_RXCNTA: Receive DMA Count Register A

<b>Bit</b>	<b>31</b>	<b>30</b>	<b>29</b>	<b>28</b>	<b>27</b>	<b>26</b>	<b>25</b>	<b>24</b>
<b>Name</b>	0	0	0	0	0	0	0	0
<b>Bit</b>	<b>23</b>	<b>22</b>	<b>21</b>	<b>20</b>	<b>19</b>	<b>18</b>	<b>17</b>	<b>16</b>
<b>Name</b>	0	0	0	0	0	0	0	0
<b>Bit</b>	<b>15</b>	<b>14</b>	<b>13</b>	<b>12</b>	<b>11</b>	<b>10</b>	<b>9</b>	<b>8</b>
<b>Name</b>	0	0	SC_RXCNTA					
<b>Bit</b>	<b>7</b>	<b>6</b>	<b>5</b>	<b>4</b>	<b>3</b>	<b>2</b>	<b>1</b>	<b>0</b>
<b>Name</b>	SC_RXCNTA							

SC1\_RXCNTA: Address: 0x4000C820 Reset: 0x0

SC2\_RXCNTA: Address: 0x4000C020 Reset: 0x0

<b>Bitname</b>	<b>Bitfield</b>	<b>Access</b>	<b>Description</b>
SC_RXCNTA	[13:0]	RW	The offset from the start of DMA receive buffer A at which the next byte will be written. This register is set to zero when the buffer is loaded and when the DMA is reset. If this register is written when the buffer is not loaded, the buffer is loaded.

**Register 8.29. SCx\_RXCNTB****SC1\_RXCNTB: Receive DMA Count Register B****SC2\_RXCNTB: Receive DMA Count Register B**

<b>Bit</b>	<b>31</b>	<b>30</b>	<b>29</b>	<b>28</b>	<b>27</b>	<b>26</b>	<b>25</b>	<b>24</b>
<b>Name</b>	0	0	0	0	0	0	0	0
<b>Bit</b>	<b>23</b>	<b>22</b>	<b>21</b>	<b>20</b>	<b>19</b>	<b>18</b>	<b>17</b>	<b>16</b>
<b>Name</b>	0	0	0	0	0	0	0	0
<b>Bit</b>	<b>15</b>	<b>14</b>	<b>13</b>	<b>12</b>	<b>11</b>	<b>10</b>	<b>9</b>	<b>8</b>
<b>Name</b>	0	0	SC_RXCNTB					
<b>Bit</b>	<b>7</b>	<b>6</b>	<b>5</b>	<b>4</b>	<b>3</b>	<b>2</b>	<b>1</b>	<b>0</b>
<b>Name</b>	SC_RXCNTB							

SC1\_RXCNTB: Address: 0x4000C824 Reset: 0x0

SC2\_RXCNTB: Address: 0x4000C024 Reset: 0x0

<b>Bitname</b>	<b>Bitfield</b>	<b>Access</b>	<b>Description</b>
SC_RXCNTB	[13:0]	RW	The offset from the start of DMA receive buffer B at which the next byte will be written. This register is set to zero when the buffer is loaded and when the DMA is reset. If this register is written when the buffer is not loaded, the buffer is loaded.

# EM341

## Register 8.30. SCx\_RXCNTSAVED

SC1\_RXCNTSAVED: Saved Receive DMA Count Register

SC2\_RXCNTSAVED: Saved Receive DMA Count Register

Bit	31	30	29	28	27	26	25	24
Name	0	0	0	0	0	0	0	0
Bit	23	22	21	20	19	18	17	16
Name	0	0	0	0	0	0	0	0
Bit	15	14	13	12	11	10	9	8
Name	0	0	SC_RXCNTSAVED					
Bit	7	6	5	4	3	2	1	0
Name	SC_RXCNTSAVED							

SC1\_RXCNTSAVED: Address: 0x4000C870 Reset: 0x0

SC2\_RXCNTSAVED: Address: 0x4000C070 Reset: 0x0

Bitname	Bitfield	Access	Description
SC_RXCNTSAVED	[13:0]	R	Receive DMA count saved in SPI slave mode when nSSEL deasserts. The count is only saved the first time nSSEL deasserts.

**Register 8.31. SCx\_RXERRA****SC1\_RXERRA: DMA First Receive Error Register A****SC2\_RXERRA: DMA First Receive Error Register A**

<b>Bit</b>	<b>31</b>	<b>30</b>	<b>29</b>	<b>28</b>	<b>27</b>	<b>26</b>	<b>25</b>	<b>24</b>
<b>Name</b>	0	0	0	0	0	0	0	0
<b>Bit</b>	<b>23</b>	<b>22</b>	<b>21</b>	<b>20</b>	<b>19</b>	<b>18</b>	<b>17</b>	<b>16</b>
<b>Name</b>	0	0	0	0	0	0	0	0
<b>Bit</b>	<b>15</b>	<b>14</b>	<b>13</b>	<b>12</b>	<b>11</b>	<b>10</b>	<b>9</b>	<b>8</b>
<b>Name</b>	0	0	SC_RXERRA					
<b>Bit</b>	<b>7</b>	<b>6</b>	<b>5</b>	<b>4</b>	<b>3</b>	<b>2</b>	<b>1</b>	<b>0</b>
<b>Name</b>	SC_RXERRA							

SC1\_RXERRA: DMA First Receive Error Register A

SC2\_RXERRA: DMA First Receive Error Register A

<b>Bitname</b>	<b>Bitfield</b>	<b>Access</b>	<b>Description</b>
SC_RXERRA	[13:0]	R	The offset from the start of DMA receive buffer A of the first byte received with a parity, frame, or overflow error. Note that an overflow error occurs at the input to the receive FIFO, so this offset is 4 bytes before the overflow position. If there is no error, it reads zero. This register will not be updated by subsequent errors until the buffer unloads and is reloaded, or the receive DMA is reset.

# EM341

## Register 8.32. SCx\_RXERRB

SC1\_RXERRB: DMA First Receive Error Register B

SC2\_RXERRB: DMA First Receive Error Register B

Bit	31	30	29	28	27	26	25	24
Name	0	0	0	0	0	0	0	0
Bit	23	22	21	20	19	18	17	16
Name	0	0	0	0	0	0	0	0
Bit	15	14	13	12	11	10	9	8
Name	0	0	SC_RXERRB					
Bit	7	6	5	4	3	2	1	0
Name	SC_RXERRB							

SC1\_RXERRB: Address: 0x4000C838 Reset: 0x0

SC2\_RXERRB: Address: 0x4000C038 Reset: 0x0

Bitname	Bitfield	Access	Description
SC_RXERRB	[13:0]	R	The offset from the start of DMA receive buffer B of the first byte received with a parity, frame, or overflow error. Note that an overflow error occurs at the input to the receive FIFO, so this offset is 4 bytes before the overflow position. If there is no error, it reads zero. This register will not be updated by subsequent errors until the buffer unloads and is reloaded, or the receive DMA is reset.

## 9. General Purpose Timers (TIM1 and TIM2)

### 9.1. Introduction

Each of the EM341's two general-purpose timers consists of a 16-bit auto-reload counter driven by a programmable prescaler. They may be used for a variety of purposes, including measuring the pulse lengths of input signals (input capture) or generating output waveforms (output compare and PWM). Pulse lengths and waveform periods can be modulated from a few microseconds to several milliseconds using the timer prescaler. The timers are completely independent, and do not share any resources. They can be synchronized together as described in the "9.3.14. Timer Synchronization" on page 138.

The two general-purpose timers, TIM1 and TIM2, have the following features:

- 16-bit up, down, or up/down auto-reload counter.
- Programmable prescaler to divide the counter clock by any power of two from 1 through 32768.
- 4 independent channels for:
  - Input capture
  - Output compare
  - PWM generation (edge- and center-aligned mode)
  - One-pulse mode output
- Synchronization circuit to control the timer with external signals and to interconnect the timers.
- Flexible clock source selection:
  - Peripheral clock (PCLK at 6 or 12 MHz)
  - 32.768 kHz external clock (if available)
  - 1 kHz clock
  - GPIO input
- Interrupt generation on the following events:
  - Update: counter overflow/underflow, counter initialization (software or internal/external trigger)
  - Trigger event (counter start, stop, initialization or count by internal/external trigger)
  - Input capture
  - Output compare
- Supports incremental (quadrature) encoders and Hall sensors for positioning applications.
- Trigger input for external clock or cycle-by-cycle current management.

Figure 9.1 shows an overview of a timer's internal structure.

**Note:** Because the two timers are identical, the notation TIMx refers to either TIM1 or TIM2. For example, TIMx\_PSC refers to both TIM1\_PSC and TIM2\_PSC. Similarly, "y" refers to any of the four channels of a given timer, so for example, OCy refers to OC1, OC2, OC3, and OC4.



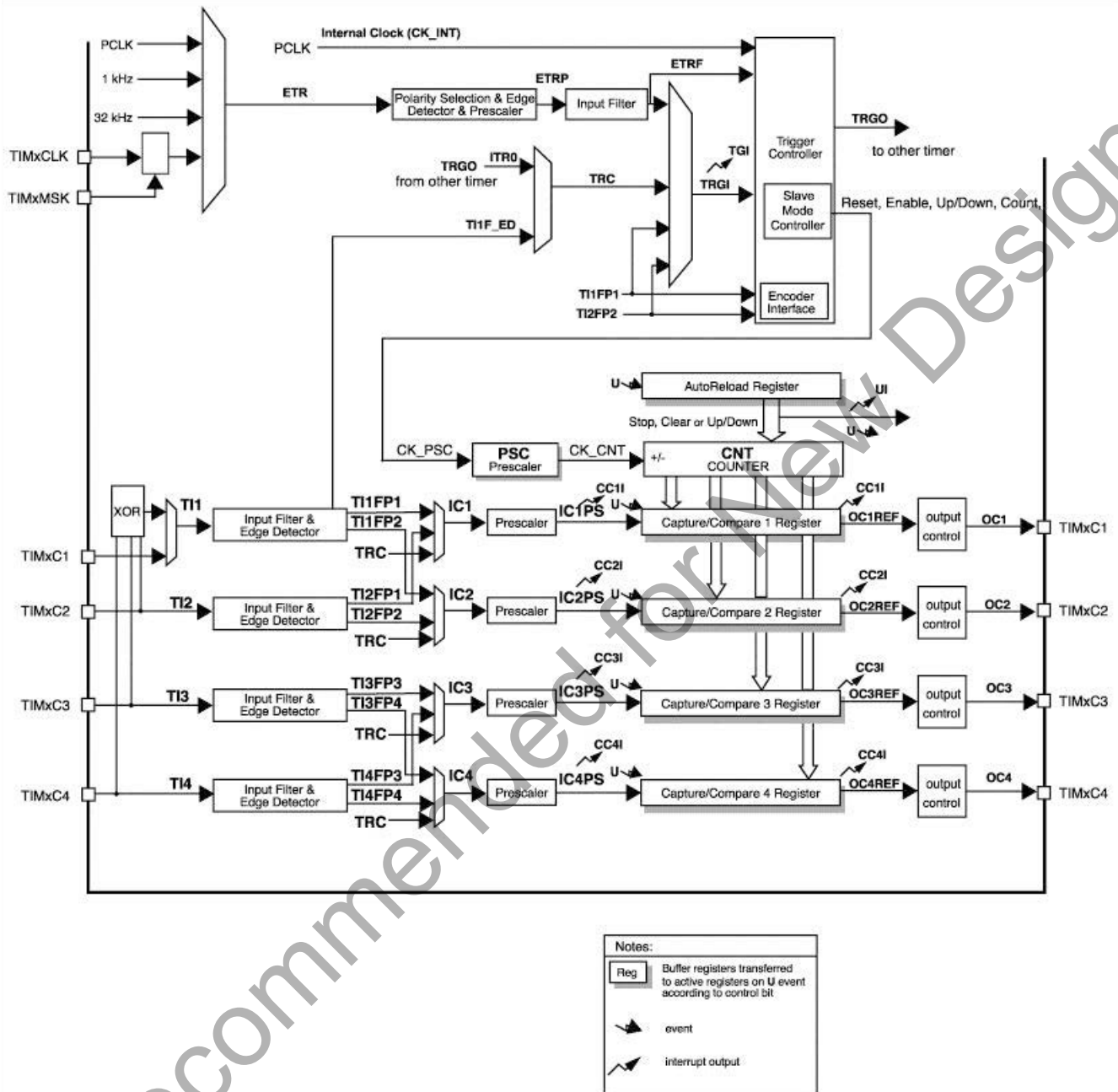

**Figure 9.1. General-Purpose Timer Block Diagram**

**Note:** The internal signals shown in Figure 9.1 are described in the Timer Signal Descriptions "9.3.15. Timer Signal Descriptions" on page 142, and are used throughout the text to describe how the timer components are interconnected.

## 9.2. GPIO Usage

The timers can optionally use GPIOs in the PA and PB ports for external inputs or outputs. As with all EM341 digital inputs, a GPIO used as a timer input can be shared with other uses of the same pin. Available timer inputs include an external timer clock, a clock mask, and four input channels. Any GPIO used as a timer output must be configured as an alternate output and is controlled only by the timer.

Many of the GPIOs that can be assigned as timer outputs can also be used by another on-chip peripheral such as a serial controller. Using a GPIO as a timer output takes precedence over another peripheral function, as long as the channel is configured as an output in the TIMx\_CCMR1 register and is enabled in the TIMx\_CCER register.

The GPIOs that can be used by Timer 1 are fixed, but the GPIOs that can be used as Timer 2 channels can be mapped to either of two pins, as shown in Table 9.1. The Timer 2 Option Register (TIM2\_OR) has four single bit fields (TIM\_REMAPCy) that control whether a Timer 2 channel is mapped to its default GPIO in port PA, or remapped to a GPIO in PB.

Table 9.1 specifies the pins that may be assigned to Timer 1 and Timer 2 functions.

**Table 9.1. Timer GPIO Usage**

Signal (Direction)	TIMxC1 (In or Out)	TIMxC2 (In or Out)	TIMxC3 (In or Out)	TIMxC4 (In or Out)	TIMxCLK (In)	TIMxMSK (In)
Timer 1	PB6	PB7	PA6	PA7	PB0	PB5
Timer 2 (TIM_REMAPCy = 0)	PA0	PA3	PA1	PA2	PB5	PB0
Timer 2 (TIM_REMAPCy = 1)	PB1	PB2	PB3	PB4	PB5	PB0

The TIMxCLK and TIMxMSK inputs can be used only in the external clock modes; refer to "9.3.3.2. External Clock Source Mode 1" on page 122 and "9.3.3.3. External Clock Source Mode 2" on page 123 for details concerning their use.

## 9.3. Timer Functional Description

### 9.3.1. Time-Base Unit

The main block of the general purpose timer is a 16-bit counter with its related auto-reload register. The counter can count up, down, or alternate up and down. The counter clock can be divided by a prescaler.

The counter, the auto-reload register, and the prescaler register can be written to or read by software. This is true even when the counter is running.

The time-base unit includes:

- Counter Register (TIMx\_CNT)
- Prescaler Register (TIMx\_PSC)
- Auto-Reload Register (TIMx\_ARR)

Some timer registers cannot be directly accessed by software, which instead reads and writes a "buffer register". The internal registers actually used for timer operations are called "shadow registers".

The auto-reload register is buffered. Writing to or reading from the auto-reload register accesses the buffer register. The contents of the buffer register are transferred into the shadow register permanently or at each update event (UEV), depending on the auto-reload buffer enable bit (TIM\_ARBE) in the TIMx\_CR1 register. The UEV is generated when both the counter reaches the overflow (or underflow when down-counting) and when the TIM\_UDIS bit equals 0 in the TIMx\_CR1 register. It can also be generated by software. UEV generation is described in detail for each configuration.

The counter is clocked by the prescaler output CK\_CNT, which is enabled only when the counter enable bit (TIM\_CEN) in the TIMx\_CR1 register is set. Refer also to the slave mode controller description in "9.3.13. Timers

and External Trigger Synchronization" on page 135 to get more details on counter enabling. Note that the actual counter enable signal CNT\_EN is set one clock cycle after TIM\_CEN.

**Note:** When the EM341 enters debug mode and the ARM® Cortex™-M3 core is halted, the counters continue to run normally.

### 9.3.1.1. Prescaler

The prescaler can divide the counter clock frequency by power of two from 1 through 32768. It is based on a 16-bit counter controlled through the 4-bit TIM\_PSCEXP bit field in the TIMx\_PSC register. The factor by which the counter is divided is two raised to the power TIM\_PSCEXP ( $2^{TIM\_PSCEXP}$ ).

It can be changed on the fly as this control register is buffered. The new prescaler ratio is used starting at the next UEV.

Figure 9.2 gives an example of the counter behavior when the prescaler ratio is changed on the fly.

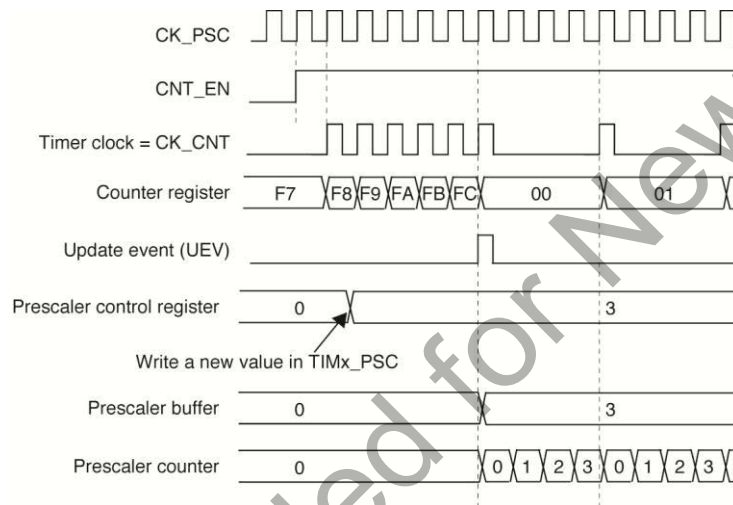

**Figure 9.2. Counter Modes**

### 9.3.2. Counter Modes

#### 9.3.2.1. Up-Counting Mode

In up-counting mode, the counter counts from 0 to the auto-reload value (contents of the TIMx\_ARR register), then restarts from 0 and generates a counter overflow event.

A UEV can be generated at each counter overflow, by setting the TIM\_UG bit in the TIMx\_EGR register, or by using the slave mode controller.

Software can disable the UEV by setting the TIM\_UDIS bit in the TIMx\_CR1 register, to avoid updating the shadow registers while writing new values in the buffer registers. No UEV will occur until the TIM\_UDIS bit is written to 0. Both the counter and the prescaler counter restart from 0, but the prescale rate does not change. In addition, if the TIM\_URS bit in the TIMx\_CR1 register is set, setting the TIM\_UG bit generates a UEV but without setting the INT\_TIMUIF flag. Thus no interrupt request is sent. This avoids generating both update and capture interrupts when clearing the counter on the capture event.

When a UEV occurs, the update flag (the INT\_TIMUIF bit in the INT\_TIMxFLAG register) is set (unless TIM\_URS is 1) and the following registers are updated:

- The buffer of the prescaler is reloaded with the buffer value (contents of the TIMx\_PSC register).
- The auto-reload shadow register is updated with the buffer value (TIMx\_ARR).

Figures 9.3, 9.4, 9.5, and 9.6 show some examples of the counter behavior for different clock frequencies when TIMx\_ARR = 0x36.

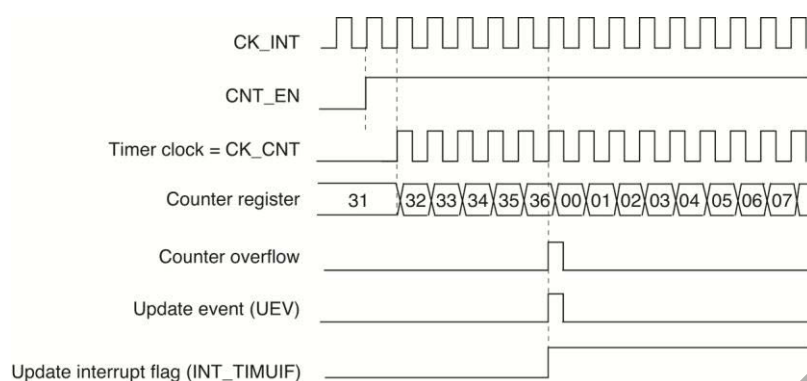

Figure 9.3. Counter Timing Diagram, Internal Clock Divided by 1

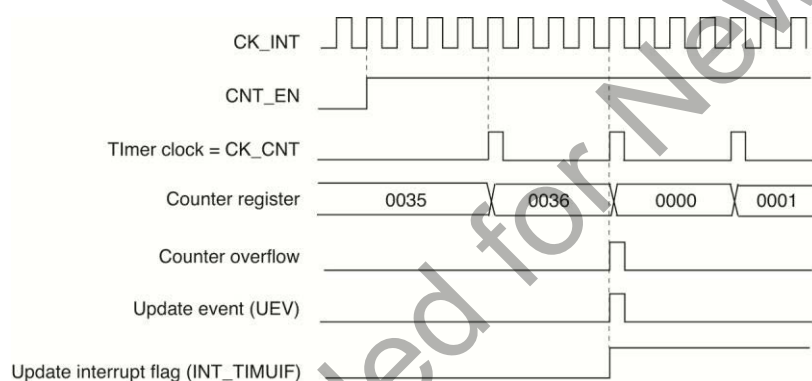

Figure 9.4. Counter Timing Diagram, Internal Clock Divided by 4

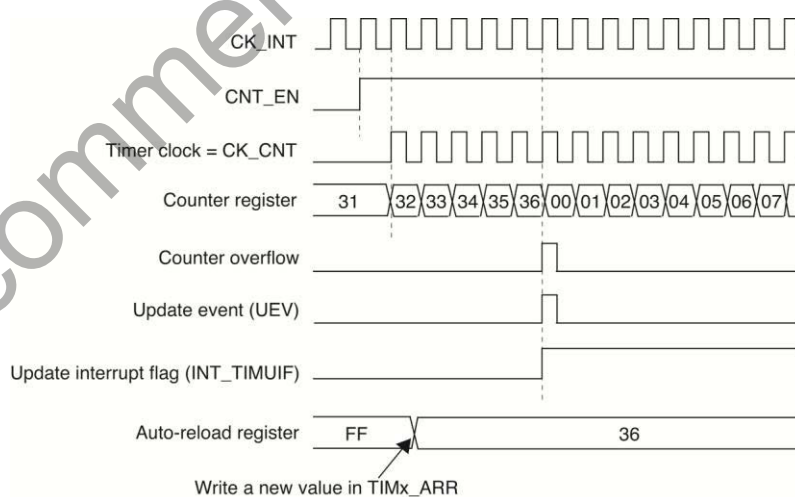
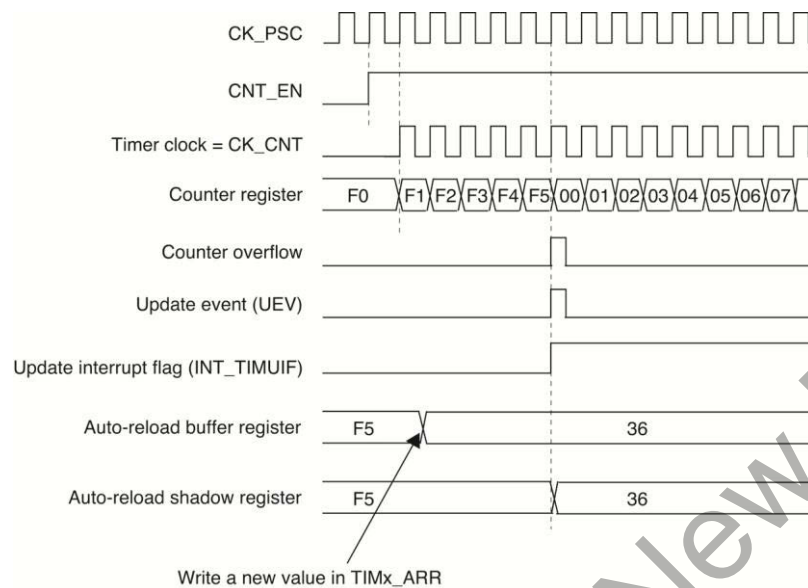

Figure 9.5. Counter Timing Diagram, Update Event when  $TIM\_ARBE = 0$  (TIMx\_ARR Not Buffered)



**Figure 9.6. Counter Timing Diagram, Update Event when TIM\_ARBE = 1 (TIMx\_ARR Buffered)**

### 9.3.2.2. Down-Counting Mode

In down-counting mode, the counter counts from the auto-reload value (contents of the TIMx\_ARR register) down to 0, then restarts from the auto-reload value and generates a counter underflow event.

A UEV can be generated at each counter underflow, by setting the TIM\_UG bit in the TIMx\_EGR register, or by using the slave mode controller. Software can disable the UEV by setting the TIM\_UDIS bit in the TIMx\_CR1 register, to avoid updating the shadow registers while writing new values in the buffer registers. No UEV occurs until the TIM\_UDIS bit is written to 0. However, the counter restarts from the current auto-reload value, whereas the prescaler's counter restarts from 0, but the prescale rate doesn't change.

In addition, if the TIM\_URS bit in the TIMx\_CR1 register is set, setting the TIM\_UG bit generates a UEV, but without setting the INT\_TIMUIF flag. Thus no interrupt request is sent. This avoids generating both update and capture interrupts when clearing the counter on the capture event.

When a UEV occurs, the update flag (the INT\_TIMUIF bit in the INT\_TIMxFLAG register) is set (unless TIM\_URS is 1) and the following registers are updated:

- The prescaler shadow register is reloaded with the buffer value (contents of the TIMx\_PSC register).
- The auto-reload active register is updated with the buffer value (contents of the TIMx\_ARR register). The auto-reload is updated before the counter is reloaded, so that the next period is the expected one.

Figure 9.7 and Figure 9.8 show some examples of the counter behavior for different clock frequencies when TIMx\_ARR = 0x36.

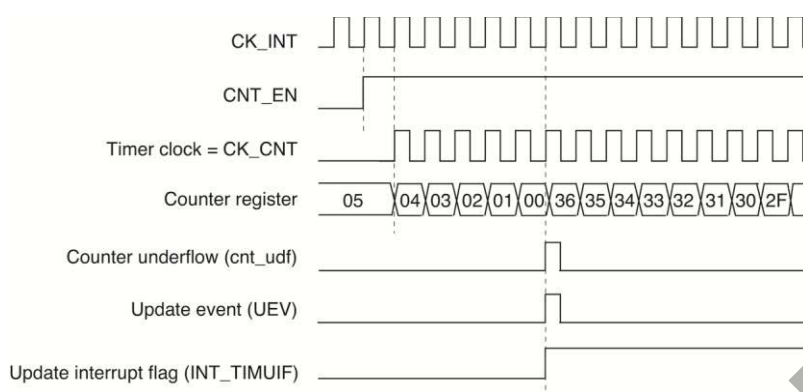

**Figure 9.7. Counter Timing Diagram, Internal Clock Divided by 1**

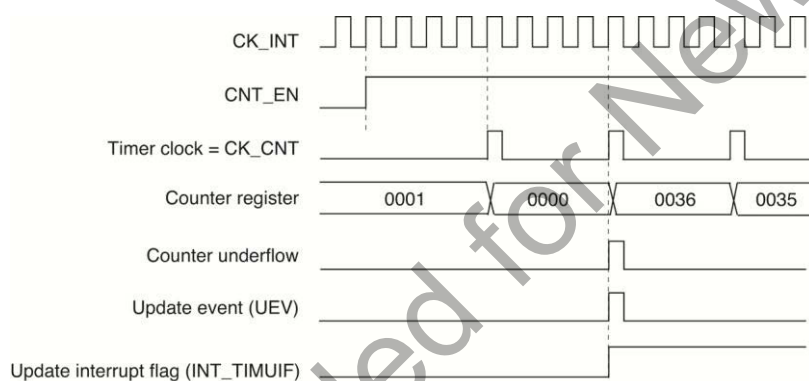

**Figure 9.8. Counter Timing Diagram, Internal Clock Divided by 4**

### 9.3.2.3. Center-Aligned Mode (Up/Down Counting)

In center-aligned mode, the counter counts from 0 to the auto-reload value (contents of the TIMx\_ARR register) – 1 and generates a counter overflow event, then counts from the autoreload value down to 1 and generates a counter underflow event. Then it restarts counting from 0.

In this mode, the direction bit (TIM\_DIR in the TIMx\_CR1 register) cannot be written. It is updated by hardware and gives the current direction of the counter.

The UEV can be generated at each counter overflow and at each counter underflow. Setting the TIM\_UG bit in the TIMx\_EGR register by software or by using the slave mode controller also generates a UEV. In this case, the both the counter and the prescaler's counter restart counting from 0.

Software can disable the UEV by setting the TIM\_UDIS bit in the TIMx\_CR1 register. This avoids updating the shadow registers while writing new values in the buffer registers. Then no UEV occurs until the TIM\_UDIS bit has been written to 0. However, the counter continues counting up and down, based on the current auto-reload value.

In addition, if the TIM\_URS bit in the TIMx\_CR1 register is set, setting the TIM\_UG bit generates a UEV, but without setting the INT\_TIMUIF flag. Thus no interrupt request is sent. This avoids generating both update and capture interrupt when clearing the counter on the capture event.

When a UEV occurs, the update flag (the INT\_TIMUIF bit in the INT\_TIMxFLAG register) is set (unless TIM\_URS is 1) and the following registers are updated:

- The prescaler shadow register is reloaded with the buffer value (contents of the TIMx\_PSC register).
- The auto-reload active register is updated with the buffer value (contents of the TIMx\_ARR register). If the update source is a counter overflow, the auto-reload is updated before the counter is reloaded, so that the next period is the expected one. The counter is loaded with the new value.

Figures 9.9, 9.10, and 9.11 show some examples of the counter behavior for different clock frequencies.

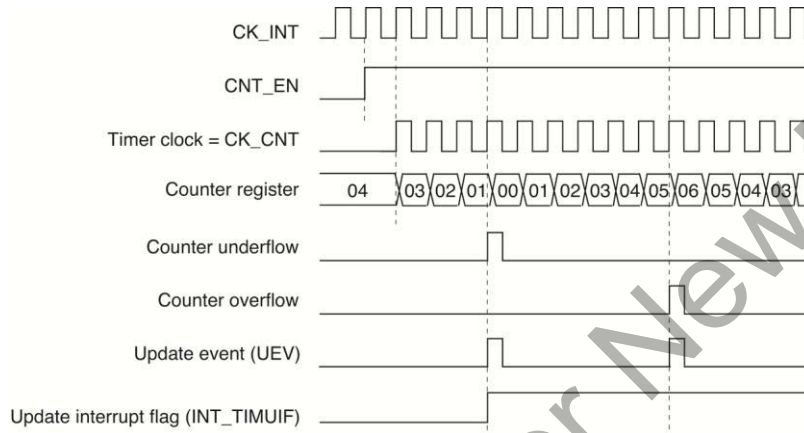

**Figure 9.9. Counter Timing Diagram, Internal Clock Divided by 1, TIMx\_ARR = 0x6**

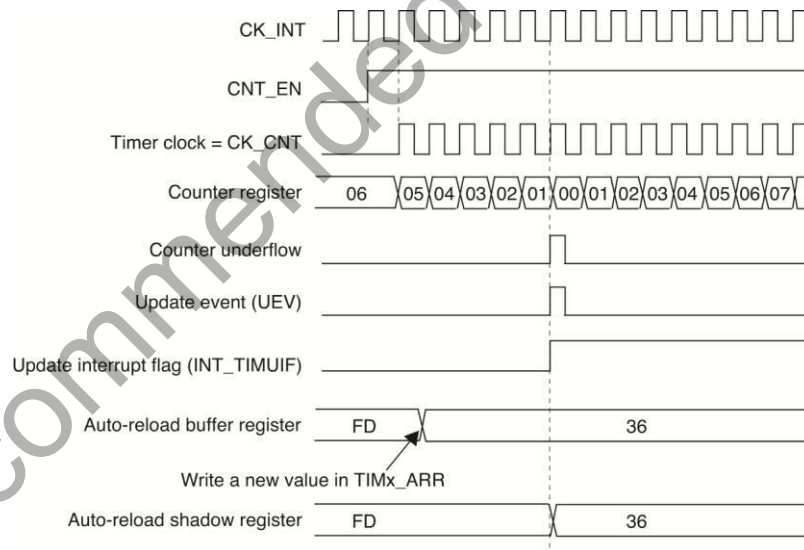

**Figure 9.10. Counter Timing Diagram, Update Event with TIM\_ARBE = 1 (Counter Underflow)**

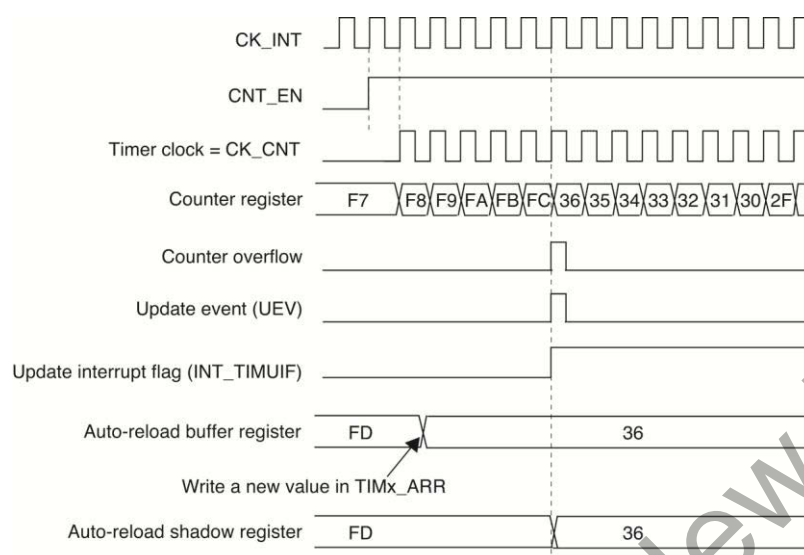

**Figure 9.11. Counter Timing Diagram, Update Event with TIM\_ARBE = 1 (Counter Overflow)**

### 9.3.3. Clock Selection

The counter clock can be provided by the following clock sources:

- Internal clock (PCLK)
- External clock mode 1: external input pin (TIy)
- External clock mode 2: external trigger input (ETR)
- Internal trigger input (ITR0): using the other timer as prescaler. Refer to "9.3.14.1. Using One Timer as Prescaler for the Other Timer" on page 138 for more details.

#### 9.3.3.1. Internal Clock Source (CK\_INT)

The internal clock is selected when the slave mode controller is disabled (TIM\_SMS = 000 in the TIMx\_SMCR register). In this mode, the TIM\_CEN, TIM\_DIR (in the TIMx\_CR1 register), and TIM\_UG bits (in the TIMx\_EGR register) are actual control bits and can be changed only by software, except for TIM\_UG, which remains cleared automatically. As soon as the TIM\_CEN bit is written to 1, the prescaler is clocked by the internal clock CK\_INT.

Figure 9.12 shows the behavior of the control circuit and the up-counter in normal mode, without prescaling.

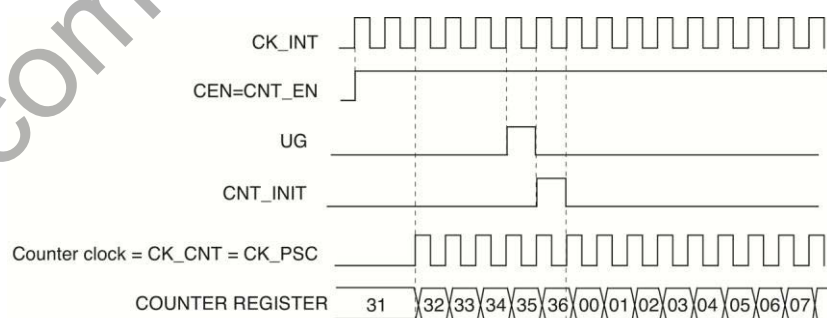
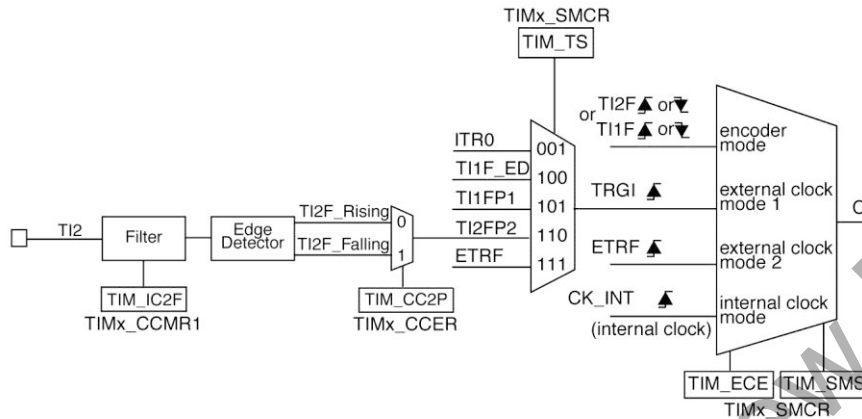

**Figure 9.12. Control Circuit in Normal Mode, Internal Clock Divided by 1**



## 9.3.3.2. External Clock Source Mode 1

This mode is selected when TIM\_SMS = 111 in the TIMx\_SMCR register. The counter can count at each rising or falling edge on a selected input. Figure 9.13 shows the registers and signals used in the example that follows.



**Figure 9.13. TI2 External Clock Connection Example**

For example, to configure the up-counter to count in response to a rising edge on the TI2 input, use the following procedure:

- Configure channel 2 to detect rising edges on the TI2 input: Write TIM\_CC2S = 01 in the TIMx\_CCMR1 register.
- Configure the input filter duration: Write the TIM\_IC2F bits in the TIMx\_CCMR1 register (if no filter is needed, keep TIM\_IC2F = 0000).

**Note:** The capture prescaler is not used for triggering, so it does not need to be configured.

- Select rising edge polarity: Write TIM\_CC2P = 0 in the TIMx\_CCER register.
- Configure the timer in external clock mode 1: Write TIM\_SMS = 111 in the TIMx\_SMCR register.
- Select TI2 as the input source: Write TIM\_TS = 110 in the TIMx\_SMCR register.
- Enable the counter: Write TIM\_CEN = 1 in the TIMx\_CR1 register.

When a rising edge occurs on TI2, the counter counts once and the INT\_TIMTIF flag is set. The delay between the rising edge on TI2 and the actual clock of the counter is due to the resynchronization circuit on the TI2 input. The relationship between rising edges on TI2 and the resulting counter clocks is shown in Figure 9.14.

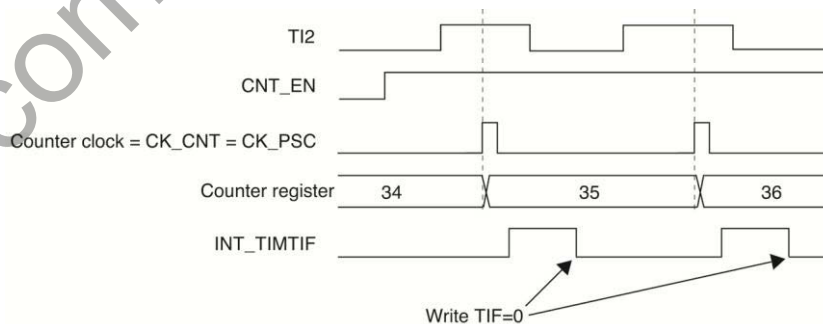

**Figure 9.14. Control Circuit in External Clock Mode 1**

### 9.3.3.3. External Clock Source Mode 2

This mode is selected by writing `TIM_ECE = 1` in the `TIMx_SMCR` register. The counter can count at each rising or falling edge on the external trigger input ETR.

The `TIM_EXTRIGSEL` bits in the `TIMx_OR` register select a clock signal that drives ETR, as shown in Table 9.2.

**Table 9.2. TIM\_EXTRIGSEL Clock Signal Selection**

TIM_EXTRIGSEL Bits	Clock Signal Selection
00	PCLK (peripheral clock). When running from the 24 MHz crystal oscillator, the PCLK frequency is 12 MHz. When the 12 MHz RC oscillator is in use, the frequency is 6 MHz.
01	Calibrated 1 kHz internal RC oscillator
10	Optional 32.786 kHz clock
11	TIMxCLK pin. If the <code>TIM_CLKMSKEN</code> bit in the <code>TIMx_OR</code> register is set, this signal is AND'ed with the <code>TIMxMSK</code> pin providing a gated clock input.

Figure 9.15 gives an overview of the external trigger input block.

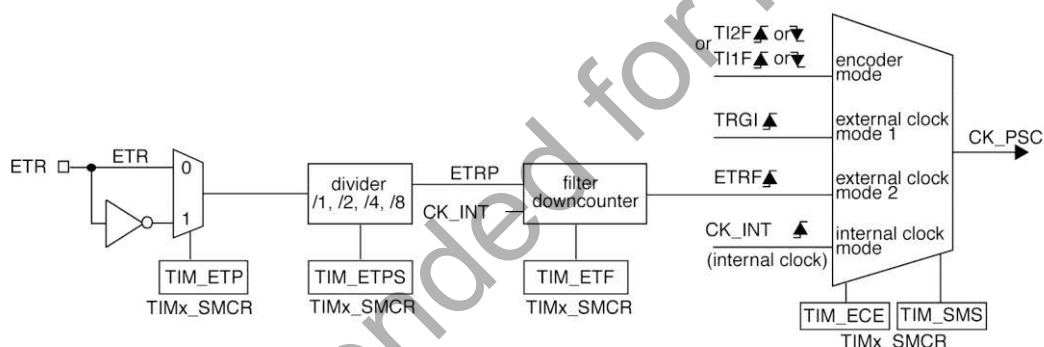

**Figure 9.15. External Trigger Input Block**

For example, to configure the up-counter to count each 2 rising edges on ETR, use the following procedure:

- Since no filter is needed in this example, write `TIM ETF = 0000` in the `TIMx_SMCR` register.
- Set the prescaler: Write `TIM_ETPS = 01` in the `TIMx_SMCR` register.
- Select rising edge detection on ETR: Write `TIM_ETP = 0` in the `TIMx_SMCR` register.
- Enable external clock mode 2: Write `TIM_ECE = 1` in the `TIMx_SMCR` register.
- Enable the counter: Write `TIM_CEN = 1` in the `TIMx_CR1` register.

The counter counts once each two ETR rising edges. The delay between the rising edge on ETR and the actual clock of the counter is due to the resynchronization circuit on the ETRP signal.

Figure 9.16 illustrates counting every two rising edges of ETR using external clock mode 2.

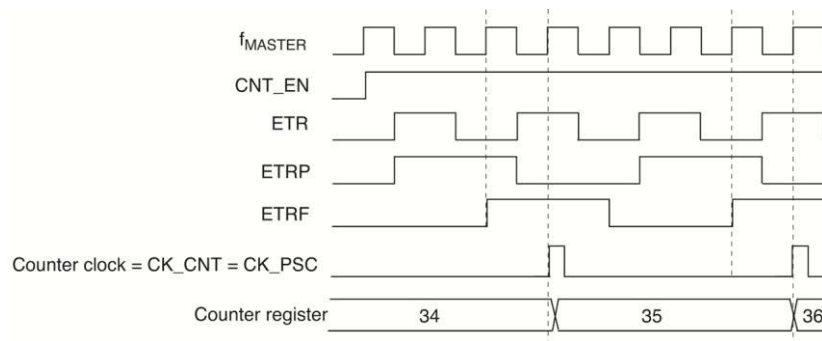

Figure 9.16. Control Circuit in External Clock Mode 2

9.3.4. Capture/Compare Channels

Each capture/compare channel is built around a capture/compare register including a shadow register, an input stage for capture with digital filter, multiplexing and prescaler, and an output stage with comparator and output control.

Figure 9.17 gives an overview of the input stage of one capture/compare channel. The input stage samples the corresponding  $Ti$  input to generate a filtered signal ( $TiF$ ). Then an edge detector with polarity selection generates a signal ( $TiFPy$ ) which can be used either as trigger input by the slave mode controller or as the capture command. It is prescaled before the capture register ( $ICyPS$ ).

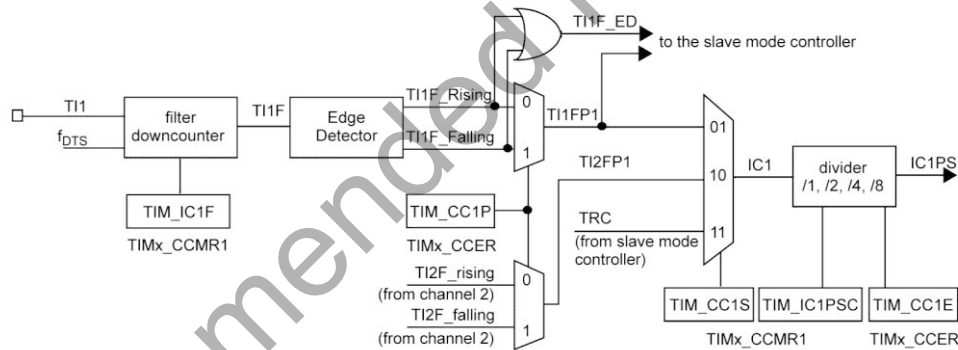

Figure 9.17. Capture/Compare Channel (Example: Channel 1 Input Stage)

The output stage generates an intermediate reference signal,  $OCyREF$ , which is only used internally.  $OCyREF$  is always active high, but it may be inverted to create the output signal,  $OCy$ , that controls a GPIO output. Figure 9.18 shows the basic elements of a capture/compare channel.

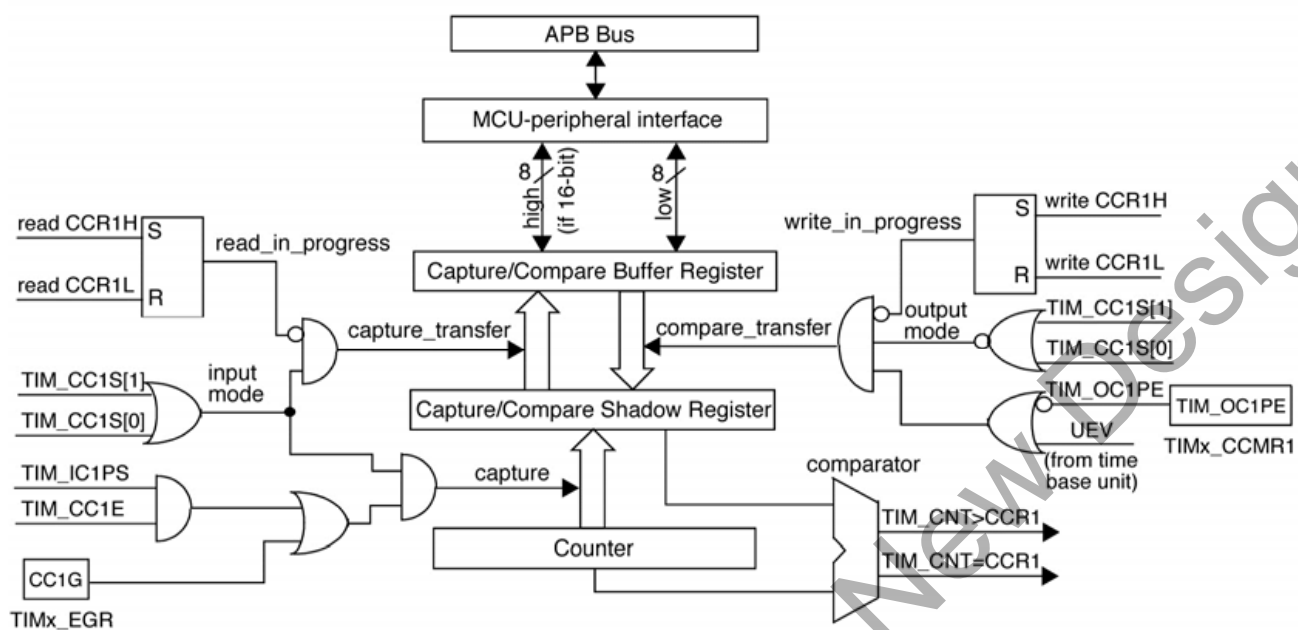
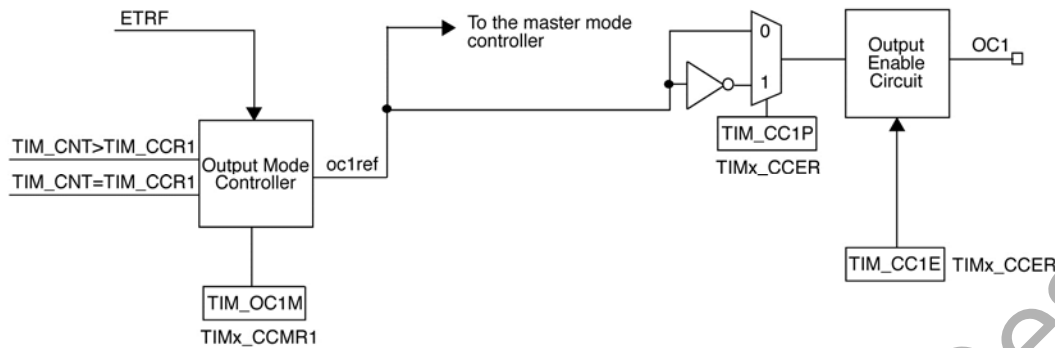

Figure 9.18. Capture/Compare Channel 1 Main Circuit



**Figure 9.19. Output Stage of Capture/Compare Channel (Channel 1)**

The capture/compare block is made of a buffer register and a shadow register. Writes and reads always access the buffer register.

In capture mode, captures are first written to the shadow register, then copied into the buffer register.

In compare mode, the content of the buffer register is copied into the shadow register which is compared to the counter.

### 9.3.5. Input Capture Mode

In input capture mode, a capture/compare register ( $TIMx\_CCRy$ ) latches the value of the counter after a transition is detected by the corresponding  $ICy$  signal. When a capture occurs, the corresponding  $INT\_TIMCCyIF$  flag in the  $INT\_TIMxFLAG$  register is set, and an interrupt request is sent if enabled.

If a capture occurs when the  $INT\_TIMCCyIF$  flag is already high, then the missed capture flag  $INT\_TIMMISSCCyIF$  in the  $INT\_TIMxMISS$  register is set.  $INT\_TIMCCyIF$  can be cleared by software writing a 1 to its bit or reading the captured data stored in the  $TIMx\_CCRy$  register. To clear the  $INT\_TIMMISSCCyIF$  bit, write a 1 to it.

The following example shows how to capture the counter value in the  $TIMx\_CCR1$  when the  $TI1$  input rises.

- Select the active input:  $TIMx\_CCR1$  must be linked to the  $TI1$  input, so write the  $TIM\_CC1S$  bits to 01 in the  $TIMx\_CCMR1$  register. As soon as  $TIM\_CC1S$  becomes different from 00, the channel is configured in input and the  $TIMx\_CCR1$  register becomes read-only.
- Program the required input filter duration with respect to the signal connected to the timer, when the input is one of the  $TIy$  ( $ICyF$  bits in the  $TIMx\_CCMR1$  register). Consider a situation in which, when toggling, the input signal is unstable during at most 5 internal clock cycles. The filter duration must be longer than these 5 clock cycles. The transition on  $TI1$  can be validated when 8 consecutive samples with the new level have been detected (sampled at  $PCLK$  frequency). To do this, write the  $TIM\_IC1F$  bits to 0011 in the  $TIMx\_CCMR1$  register.
- Select the edge of the active transition on the  $TI1$  channel: Write the  $TIM\_CC1P$  bit to 0 in the  $TIMx\_CCER$  register (rising edge in this case).
- Program the input prescaler: In this example, the capture is to be performed at each valid transition, so the prescaler is disabled (write the  $TIM\_IC1PSC$  bits to 00 in the  $TIMx\_CCMR1$  register).
- Enable capture from the counter into the capture register: Set the  $TIM\_CC1E$  bit in the  $TIMx\_CCER$  register.
- If needed, enable the related interrupt request by setting the  $INT\_TIMCC1IF$  bit in the  $INT\_TIMxCFG$  register.
- When an input capture occurs:
  - The  $TIMx\_CCR1$  register gets the value of the counter on the active transition.
  - $INT\_TIMCC1IF$  flag is set (capture/compare interrupt flag). The missed capture/compare flag  $INT\_TIMMISSCC1IF$  in  $INT\_TIMxMISS$  is also set if another capture occurs before the  $INT\_TIMCC1IF$  flag is cleared.
  - An interrupt may be generated if enabled by the  $INT\_TIMCC1IF$  bit.

To detect missed captures reliably, read captured data in TIMxCCRy before checking the missed capture/compare flag. This sequence avoids missing a capture that could happen after reading the flag and before reading the data.

**Note:** Software can generate IC interrupt requests by setting the corresponding TIM\_CCyG bit in the TIMx\_EGR register.

### 9.3.6. PWM Input Mode

This mode is a particular case of input capture mode. The procedure is the same except:

- Two ICy signals are mapped on the same Tly input.
- These two ICy signals are active on edges with opposite polarity.
- One of the two TlyFP signals is selected as trigger input and the slave mode controller is configured in reset mode.

For example, to measure the period in the TIMx\_CCR1 register and the duty cycle in the TIMx\_CCR2 register of the PWM applied on TI1, use the following procedure depending on CK\_INT frequency and prescaler value:

- Select the active input for TIMx\_CCR1: write the TIM\_CC1S bits to 01 in the TIMx\_CCMR1 register (TI1 selected).
- Select the active polarity for TI1FP1, used both for capture in the TIMx\_CCR1 and counter clear, by writing the TIM\_CC1P bit to 0 (active on rising edge).
- Select the active input for TIMx\_CCR2 by writing the TIM\_CC2S bits to 10 in the TIMx\_CCMR1 register (TI1 selected).
- Select the active polarity for TI1FP2 (used for capture in the TIMx\_CCR2) by writing the TIM\_CC2P bit to 1 (active on falling edge).
- Select the valid trigger input by writing the TIM\_TS bits to 101 in the TIMx\_SMCR register (TI1FP1 selected).
- Configure the slave mode controller in reset mode by writing the TIM\_SMS bits to 100 in the TIMx\_SMCR register.
- Enable the captures by writing the TIM\_CC1E and TIM\_CC2E bits to 1 in the TIMx\_CCER register.

Figure 9.20 illustrates this example.

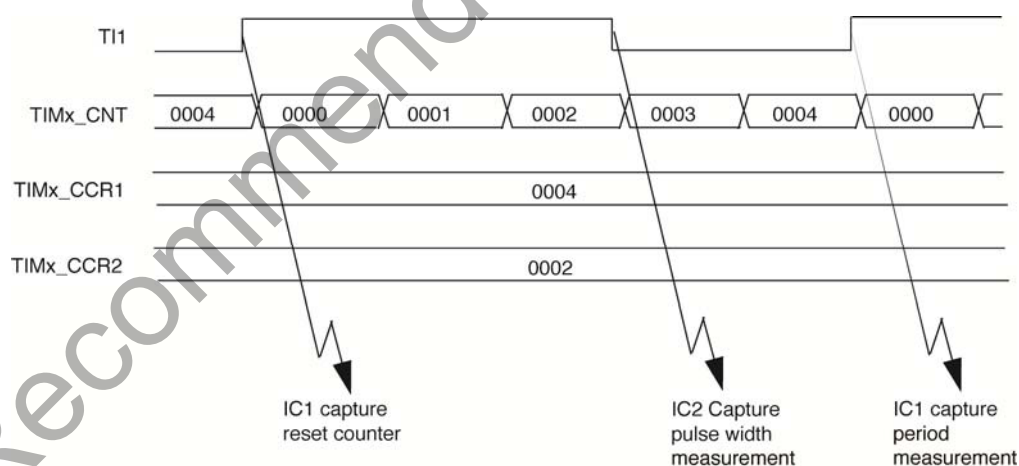

**Figure 9.20. PWM Input Mode Timing**

## 9.3.7. Forced Output Mode

In output mode (CCyS bits = 00 in the TIMx\_CCMR1 register), software can force each output compare signal (OCyREF and then OCy) to an active or inactive level independently of any comparison between the output compare register and the counter.

To force an output compare signal (OCyREF/OCy) to its active level, write 101 in the TIM\_OCyM bits in the corresponding TIMx\_CCMR1 register. OCyREF is forced high (OCyREF is always active high) and OCy gets the opposite value to the TIM\_CCyP polarity bit. For example, TIM\_CCyP = 0 defines OCy as active high, so when OCyREF is active, OCy is also set to a high level.

The OCyREF signal can be forced low by writing the TIM\_OCyM bits to 100 in the TIMx\_CCMR1 register.

The comparison between the TIMx\_CCRy shadow register and the counter is still performed and allows the INT\_TIMxCCRyIF flag to be set. Interrupt requests can be sent accordingly. This is described in "9.3.8. Output Compare Mode".

## 9.3.8. Output Compare Mode

This mode is used to control an output waveform or to indicate when a period of time has elapsed.

When a match is found between the capture/compare register and the counter, the output compare function:

- Assigns the corresponding output pin to a programmable value defined by the output compare mode (the TIM\_OCyM bits in the TIMx\_CCMR1 register) and the output polarity (the TIM\_CCyP bit in the TIMx\_CCER register). The output can be frozen (TIM\_OCyM = 000), be set active (TIM\_OCyM = 001), be set inactive (TIM\_OCyM = 010), or can toggle (TIM\_OCyM = 011) on the match.
- Sets a flag in the interrupt flag register (the INT\_TIMCCyIF bit in the INT\_TIMxFLAG register).
- Generates an interrupt if the corresponding interrupt mask is set (the TIM\_CCyIF bit in the INT\_TIMxCFG register).

The TIMx\_CCRy registers can be programmed with or without buffer registers using the TIM\_OCyBE bit in the TIMx\_CCMR1 register.

In output compare mode, the UEV has no effect on OCyREF or the OCy output. The timing resolution is one count of the counter. Output compare mode can also be used to output a single pulse (in one pulse mode).

Procedure:

1. Select the counter clock (internal, external, and prescaler).
2. Write the desired data in the TIMx\_ARR and TIMx\_CCRy registers.
3. Set the INT\_TIMCCyIF bit in INT\_TIMxCFG if an interrupt request is to be generated.
4. Select the output mode. For example, you must write TIM\_OCyM = 011, TIM\_OCyBE = 0, TIM\_CCyP = 0 and TIM\_CCyE = 1 to toggle the OCy output pin when TIMx\_CNT matches TIMx\_CCRy, TIMx\_CCRy buffer is not used, OCy is enabled and active high.
5. Enable the counter. Set the TIM\_CEN bit in the TIMx\_CR1 register.

To control the output waveform, software can update the TIMx\_CCRy register at any time, provided that the buffer register is not enabled (TIM\_OCyBE = 0). Otherwise TIMx\_CCRy shadow register is updated only at the next UEV. An example is given in Figure 9.21.

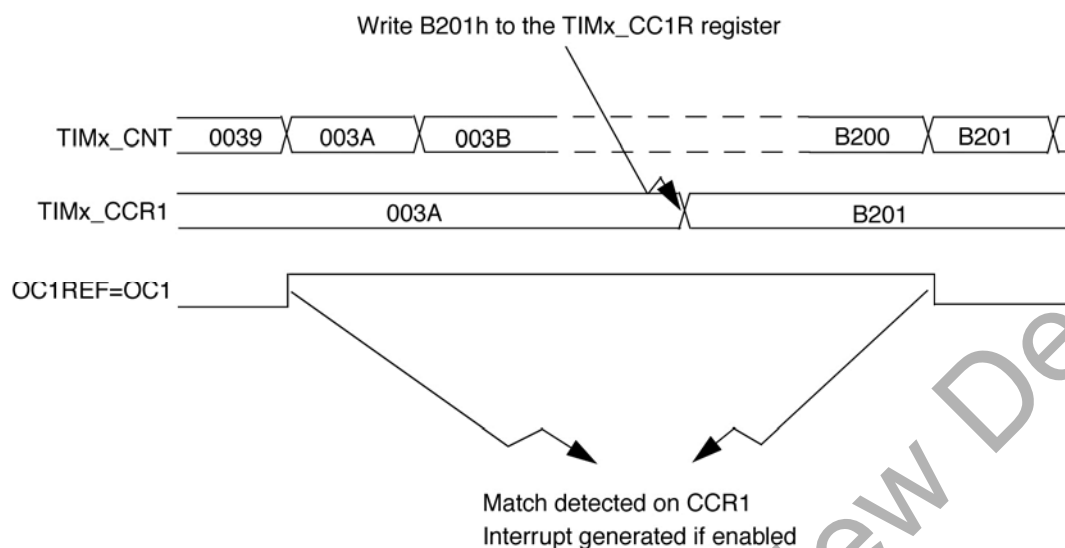

**Figure 9.21. Output Compare Mode, Toggle on OC1**

### 9.3.9. PWM Mode

Pulse width modulation mode allows you to generate a signal with a frequency determined by the value of the TIMx\_ARR register, and a duty cycle determined by the value of the TIMx\_CCRy register.

PWM mode can be selected independently on each channel (one PWM per OCy output) by writing 110 (PWM mode 1) or 111 (PWM mode 2) in the TIM\_OCyM bits in the TIMx\_CCMR1 register. The corresponding buffer register must be enabled by setting the TIM\_OCyBE bit in the TIMx\_CCMR1 register. Finally, in up-counting or center-aligned mode the auto-reload buffer register must be enabled by setting the TIM\_ARBE bit in the TIMx\_CR1 register.

Because the buffer registers are only transferred to the shadow registers when a UEV occurs, before starting the counter initialize all the registers by setting the TIM\_UG bit in the TIMx\_EGR register.

OCy polarity is software programmable using the TIM\_CCyP bit in the TIMx\_CCER register. It can be programmed as active high or active low. OCy output is enabled by the TIM\_CCyE bit in the TIMx\_CCER register. Refer to the TIMx\_CCER register description in "9.5. Registers" on page 144 for more details.

In PWM mode (1 or 2), TIMx\_CNT and TIMx\_CCRy are always compared to determine whether TIMx\_CCRy > TIMx\_CNT or TIMx\_CNT > TIMx\_CCRy, depending on the direction of the counter. The OCyREF signal is asserted only:

- When the result of the comparison changes, or
- When the output compare mode (TIM\_OCyM bits in the TIMx\_CCMR1 register) switches from the "frozen" configuration (no comparison, TIM\_OCyM = 000) to one of the PWM modes (TIM\_OCyM = 110 or 111).

This allows software to force a PWM output to a particular state while the timer is running.

The timer is able to generate PWM in edge-aligned mode or center-aligned mode depending on the TIM\_CMS bits in the TIMx\_CR1 register.

#### 9.3.9.1. PWM Edge-Aligned Mode: Up-Counting Configuration

Up-counting is active when the TIM\_DIR bit in the TIMx\_CR1 register is low. Refer to "9.3.2.1. Up-Counting Mode" on page 116.

The following example uses PWM mode 1. The reference PWM signal OCyREF is high as long as TIMx\_CNT < TIMx\_CCRy, otherwise it becomes low. If the compare value in TIMx\_CCRy is greater than the auto-reload value in TIMx\_ARR, then OCyREF is held at 1. If the compare value is 0, then OCyREF is held at 0. Figure 9.22 shows some edge-aligned PWM waveforms in an example, where TIMx\_ARR = 8.



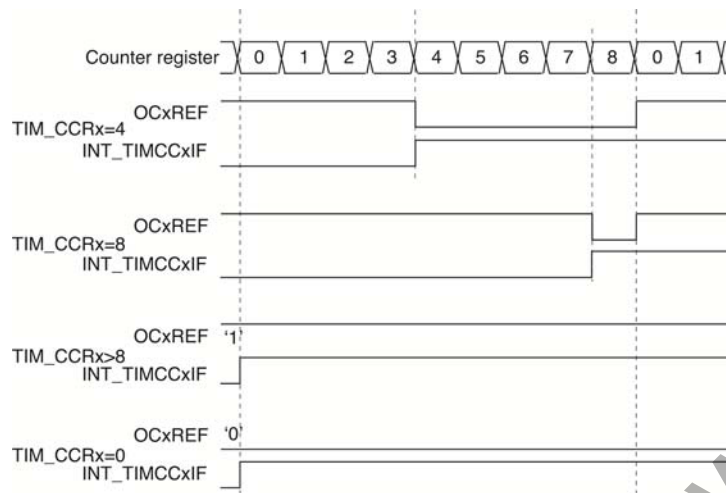

**Figure 9.22. Edge-Aligned PWM Waveforms (ARR = 8)**

### 9.3.9.2. PWM Edge-Aligned Mode: Down-Counting Configuration

Down-counting is active when the TIM\_DIR bit in the TIMx\_CR1 register is high. Refer to "9.3.2.2. Down-Counting Mode" on page 118 for more information.

In PWM mode 1, the reference signal OCyREF is low as long as  $TIMx\_CNT > TIMx\_CCRx$ , otherwise it becomes high. If the compare value in TIMx\_CCRy is greater than the auto-reload value in TIMx\_ARR, then OCyREF is held at 1. Zero-percent PWM is not possible in this mode.

### 9.3.9.3. PWM Center-Aligned Mode

Center-aligned mode is active except when the TIM\_CMS bits in the TIMx\_CR1 register are 00 (all configurations where TIM\_CMS is non-zero have the same effect on the OCyREF/OCy signals). The compare flag is set when the counter counts up, when it counts down, or when it counts up and down, depending on the TIM\_CMS bits configuration. The direction bit (TIM\_DIR) in the TIMx\_CR1 register is updated by hardware and must not be changed by software. Refer to the "9.3.2.3. Center-Aligned Mode (Up/Down Counting)" on page 119 for more information.

Figure 9.23 shows some center-aligned PWM waveforms in an example where:

- TIMx\_ARR = 8
- PWM mode is the PWM mode 1
- The output compare flag is set when the counter counts down corresponding to the center-aligned mode 1 selected for TIM\_CMS = 01 in the TIMx\_CR1 register

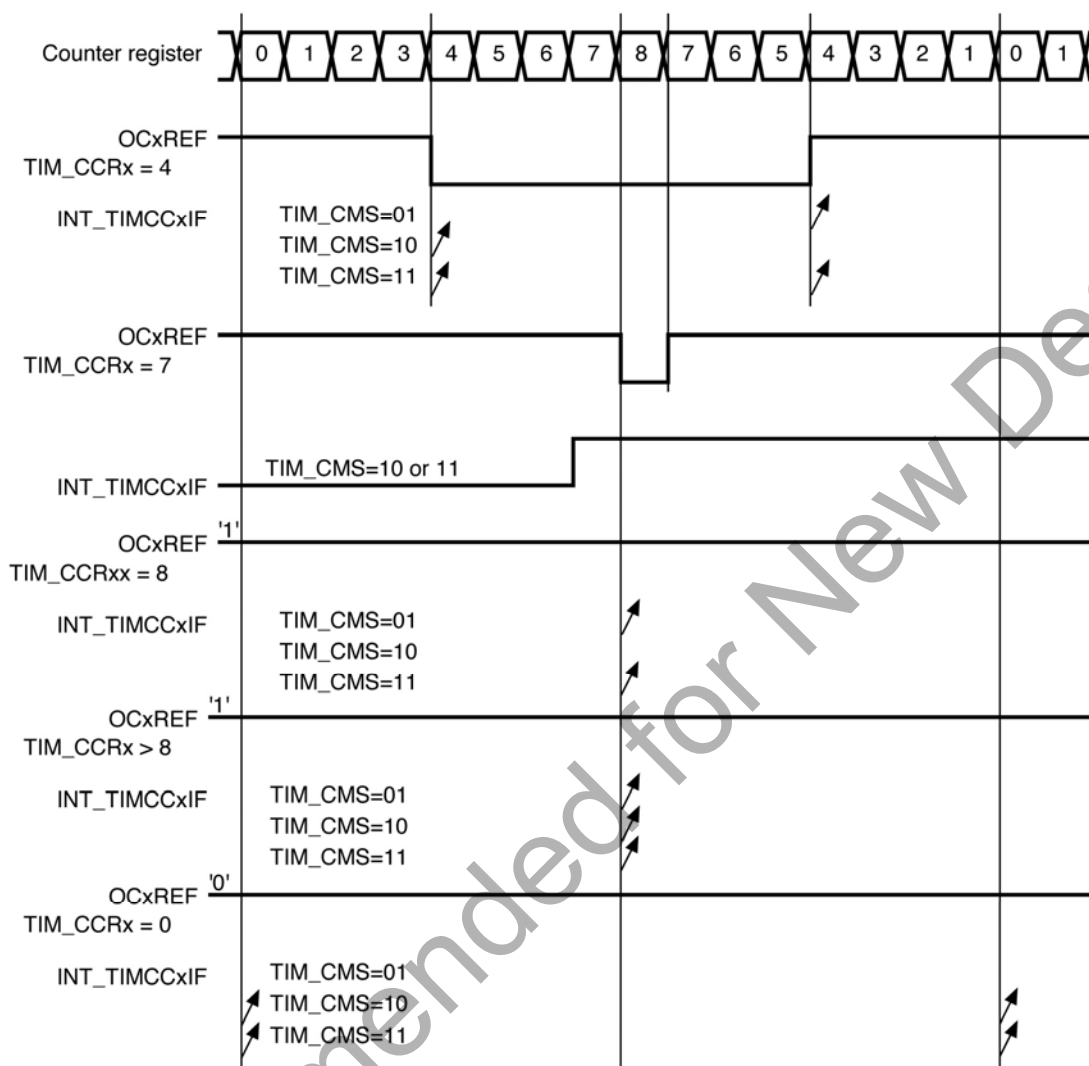

**Figure 9.23. Center-Aligned PWM Waveforms (ARR = 8)**

Hints on using center-aligned mode:

- When starting in center-aligned mode, the current up-down configuration is used. This means that the counter counts up or down depending on the value written in the TIM\_DIR bit in the TIMx\_CR1 register. The TIM\_DIR and TIM\_CMS bits must not be changed at the same time by the software.
- Writing to the counter while running in center-aligned mode is not recommended as it can lead to unexpected results. In particular:
  - The direction is not updated when the value written to the counter that is greater than the auto-reload value (TIMx\_CNT > TIMx\_ARR). For example, if the counter was counting up, it continues to count up.
  - The direction is updated when 0 or the TIMx\_ARR value is written to the counter, but no UEV is generated.
- The safest way to use center-aligned mode is to generate an update by software (setting the TIM\_UG bit in the TIMx\_EGR register) just before starting the counter, and not to write the counter while it is running.

## 9.3.10. One-Pulse Mode

One-pulse mode (OPM) is a special case of the previous modes. It allows the counter to be started in response to a stimulus and to generate a pulse with a programmable length after a programmable delay.

Starting the counter can be controlled through the slave mode controller. Generating the waveform can be done in output compare mode or PWM mode. Select OPM by setting the TIM\_OPM bit in the TIMx\_CR1 register. This makes the counter stop automatically at the next UEV.

A pulse can be correctly generated only if the compare value is different from the counter initial value. Before starting (when the timer is waiting for the trigger), the configuration must be:

In up-counting:  $TIMx\_CNT < TIMx\_CCRy ? TIMx\_ARR$  (in particular,  $0 < TIMx\_CCRy$ ),

In down-counting:  $TIMx\_CNT > TIMx\_CCRy$ .

For example, to generate a positive pulse on OC1 with a length of  $t_{PULSE}$  and after a delay of  $t_{DELAY}$  as soon as a rising edge is detected on the TI2 input pin, using TI2FP2 as trigger 1:

- Map TI2FP2 on TI2: Write  $TIM\_IC2S = 01$  in the  $TIMx\_CCMR1$  register.
- TI2FP2 must detect a rising edge. Write  $TIM\_CC2P = 0$  in the  $TIMx\_CCER$  register.
- Configure TI2FP2 as trigger for the slave mode controller (TRGI): Write  $TIM\_TS = 110$  in the  $TIMx\_SMCR$  register.
- Use TI2FP2 to start the counter: Write  $TIM\_SMS$  to 110 in the  $TIMx\_SMCR$  register (trigger mode).
- The OPM waveform is defined: Write the compare registers, taking into account the clock frequency and the counter prescaler.
  - The  $t_{DELAY}$  is defined by the value written in the  $TIMx\_CCR1$  register.
  - The  $t_{PULSE}$  is defined by the difference between the auto-reload value and the compare value ( $TIMx\_ARR - TIMx\_CCR1$ ).
- To build a waveform with a transition from 0 to 1 when a compare match occurs and a transition from 1 to 0 when the counter reaches the auto-reload value:
  - Enable PWM mode 2: Write  $TIM\_OC1M = 111$  in the  $TIMx\_CCMR1$  register.
  - Optionally, enable the buffer registers: Write  $TIM\_OC1BE = 1$  in the  $TIMx\_CCMR1$  register and  $TIM\_ARBE$  in the  $TIMx\_CR1$  register. In this case, also write the compare value in the  $TIMx\_CCR1$  register, the auto-reload value in the  $TIMx\_ARR$  register, generate an update by setting the  $TIM\_UG$  bit, and wait for external trigger event on TI2.  $TIM\_CC1P$  is written to 0 in this example.

In the example, the  $TIM\_DIR$  and  $TIM\_CMS$  bits in the  $TIMx\_CR1$  register should be low.

Since only one pulse is desired, software should set the  $TIM\_OPM$  bit in the  $TIMx\_CR1$  register to stop the counter at the next UEV (when the counter rolls over from the auto-reload value back to 0).

Figure 9.24 illustrates this example.

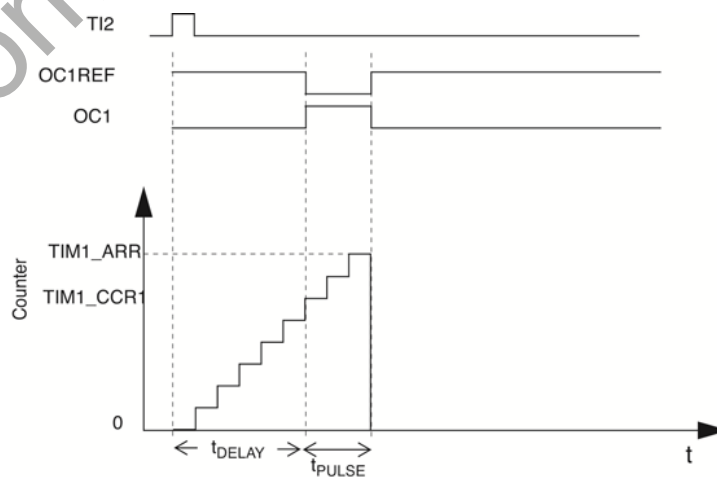

**Figure 9.24. Example of One Pulse Mode**

### 9.3.10.1. A Special Case: OCy Fast Enable

In one-pulse mode, the edge detection on the TIy input sets the TIM\_CEN bit, which enables the counter. Then the comparison between the counter and the compare value toggles the output. However, several clock cycles are needed for this operation, and it limits the minimum delay ( $t_{\text{DELAY min}}$ ) achievable.

To output a waveform with the minimum delay, set the TIM\_OCyFE bit in the TIMx\_CCMR1 register. Then OCyREF and OCy are forced in response to the stimulus, without taking the comparison into account. Its new level is the same as if a compare match had occurred. TIM\_OCyFE acts only if the channel is configured in PWM mode 1 or 2.

### 9.3.11. Encoder Interface Mode

To select encoder interface mode, write TIM\_SMS = 001 in the TIMx\_SMCR register to count only TI2 edges, TIM\_SMS = 010 to count only TI1 edges, and TIM\_SMS = 011 to count both TI1 and TI2 edges.

Select the TI1 and TI2 polarity by programming the TIM\_CC1P and TIM\_CC2P bits in the TIMx\_CCER register. If needed, program the input filter as well.

The two inputs TI1 and TI2 are used to interface to an incremental encoder (see Table 9.3). Assuming that it is enabled (the TIM\_CEN bit in the TIMx\_CR1 register = 1), the counter is clocked by each valid transition on TI1FP1 or TI2FP2 (TI1 and TI2 after input filter and polarity selection, TI1FP1 = TI1 if not filtered and not inverted, TI2FP2 = TI2 if not filtered and not inverted.) The timer input logic evaluates the sequence of the two inputs' values, and from this generates both count pulses and the direction signal. Depending on the sequence, the counter counts up or down, and hardware modifies the TIM\_DIR bit in the TIMx\_CR1 register accordingly. The TIM\_DIR bit is calculated at each transition on any input (TI1 or TI2), whether the counter is counting on TI1 only, TI2 only, or both TI1 and TI2.

Encoder interface mode acts simply as an external clock with direction selection. This means that the counter counts continuously between 0 and the auto-reload value in the TIMx\_ARR register (0 to TIMx\_ARR or TIMx\_ARR down to 0 depending on the direction), so TIMx\_ARR must be configured before starting. In the same way, the capture, compare, prescaler, and trigger output features continue to work as normal.

In this mode the counter is modified automatically following the speed and the direction of the incremental encoder, and therefore its contents always represent the encoder's position. The count direction corresponds to the rotation direction of the connected sensor. Table 9.3 summarizes the possible combinations, assuming TI1 and TI2 do not switch at the same time.

**Table 9.3. Counting Direction versus Encoder Signals**

Active Edges	Level on Opposite Signal (TI1FP1 for TI2, TI2FP2 for TI1)	TI1FP1 Signal		TI2FP2 Signal	
		Rising	Falling	Rising	Falling
Counting on TI1 only	High	Down	Up	No Count	No Count
	Low	Up	Down	No Count	No Count
Counting on TI2 only	High	No Count	No Count	Up	Down
	Low	No Count	No Count	Down	Up
Counting on TI1 and TI2	High	Down	Up	Up	Down
	Low	Up	Down	Down	Up

An external incremental encoder can be connected directly to the MCU without external interface logic. However, comparators are normally used to convert an encoder's differential outputs to digital signals, and this greatly increases noise immunity. If a third encoder output indicates the mechanical zero (or index) position, it may be connected to an external interrupt input and can trigger a counter reset.

Figure 9.25 gives an example of counter operation, showing count signal generation and direction control. It also shows how input jitter is compensated for when both inputs are used for counting. This might occur if the sensor is positioned near one of the switching points. This example assumes the following configuration:

- TIM\_CC1S = 01 (TIMx\_CCMR1 register, IC1FP1 mapped on TI1).
- TIM\_CC2S = 01 (TIMx\_CCMR2 register, IC2FP2 mapped on TI2).
- TIM\_CC1P = 0 (TIMx\_CCER register, IC1FP1 non-inverted, IC1FP1 = TI1).
- TIM\_CC2P = 0 (TIMx\_CCER register, IC2FP2 non-inverted, IC2FP2 = TI2).
- TIM\_SMS = 011 (TIMx\_SMCR register, both inputs are active on both rising and falling edges).
- TIM\_CEN = 1 (TIMx\_CR1 register, counter is enabled).

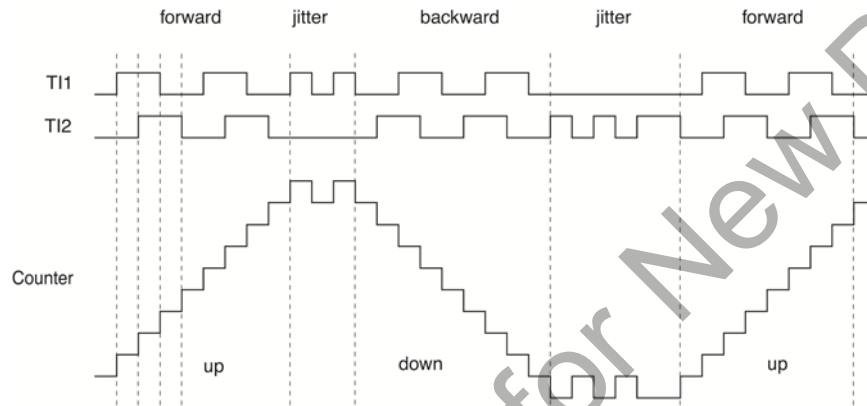

**Figure 9.25. Example of Counter Operation in Encoder Interface Mode**

Figure 9.26 gives an example of counter behavior when IC1FP1 polarity is inverted (same configuration as above except TIM\_CC1P = 1).

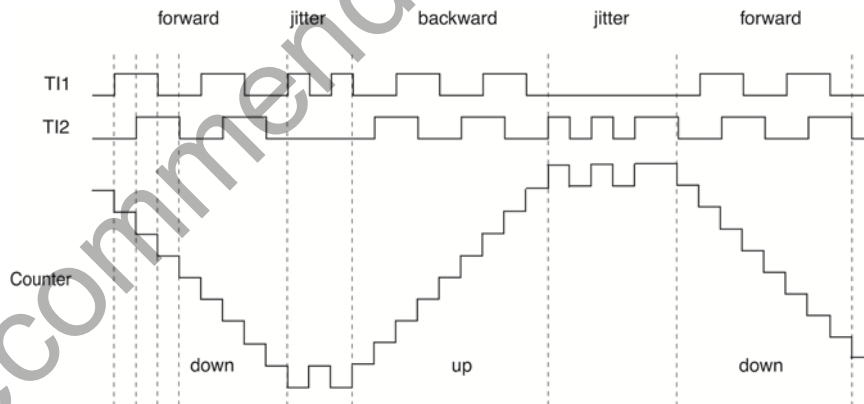

**Figure 9.26. Example of Encoder Interface Mode with IC1FP1 Polarity Inverted**

The timer configured in encoder interface mode provides information on a sensor's current position. To obtain dynamic information (speed, acceleration/deceleration), measure the period between two encoder events using a second timer configured in capture mode. The output of the encoder that indicates the mechanical zero can be used for this purpose. Depending on the time between two events, the counter can also be read at regular times. Do this by latching the counter value into a third input capture register. (In this case the capture signal must be periodic and can be generated by another timer).

### 9.3.12. Timer Input XOR Function

The TIM\_TI1S bit in the TIM1\_CR2 register allows the input filter of channel 1 to be connected to the output of a XOR gate that combines the three input pins TIMxC2 to TIMxC4.

The XOR output can be used with all the timer input functions such as trigger or input capture. It is especially useful to interface to Hall effect sensors.

### 9.3.13. Timers and External Trigger Synchronization

The timers can be synchronized with an external trigger in several modes: reset mode, gated mode, and trigger mode.

#### 9.3.13.1. Slave Mode: Reset Mode

Reset mode reinitializes the counter and its prescaler in response to an event on a trigger input. Moreover, if the TIM\_URS bit in the TIMx\_CR1 register is low, a UEV is generated. Then all the buffered registers (TIMx\_ARR, TIMx\_CCRy) are updated.

In the following example, the up-counter is cleared in response to a rising edge on the TI1 input:

- Configure the channel 1 to detect rising edges on TI1:
  - Configure the input filter duration. In this example, no filter is required so TIM\_IC1F = 0000.
  - The capture prescaler is not used for triggering, so it is not configured.
  - The TIM\_CC1S bits select the input capture source only, TIM\_CC1S = 01 in the TIMx\_CCMR1 register.
  - Write TIM\_CC1P = 0 in the TIMx\_CCER register to validate the polarity, and detect rising edges only.
- Configure the timer in reset mode: Write TIM\_SMS = 100 in the TIMx\_SMCR register.
- Select TI1 as the input source by writing TIM\_TS = 101 in the TIMx\_SMCR register.
- Start the counter: Write TIM\_CEN = 1 in the TIMx\_CR1 register.

The counter starts counting on the internal clock, then behaves normally until the TI1 rising edge. When TI1 rises, the counter is cleared and restarts from 0. In the meantime, the trigger flag is set (the INT\_TIMTIF bit in the INT\_TIMxFLAG register) and an interrupt request can be sent if enabled (depending on the INT\_TIMTIF bit in the INT\_TIMxCFG register).

Figure 9.27 shows this behavior when the auto-reload register TIMx\_ARR = 0x36. The delay between the rising edge on TI1 and the actual reset of the counter is due to the resynchronization circuit on the TI1 input.

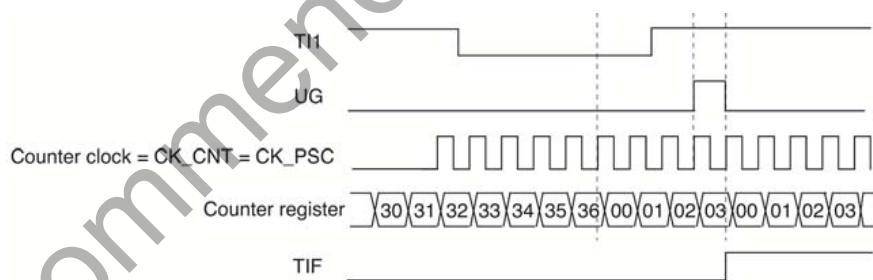

Figure 9.27. Control Circuit in Reset Mode

### 9.3.13.2. Slave Mode: Gated Mode

In gated mode the counter is enabled depending on the level of a selected input.

In the following example, the up-counter counts only when the TI1 input is low:

- Configure channel 1 to detect low levels on TI1:
  - Configure the input filter duration. In this example, no filter is required, so `TIM_IC1F = 0000`.
  - The capture prescaler is not used for triggering, so it is not configured.
  - The `TIM_CC1S` bits select the input capture source only, `TIM_CC1S = 01` in the `TIMx_CCMR1` register.
  - Write `TIM_CC1P = 1` in the `TIMx_CCER` register to validate the polarity (and detect low level only).
- Configure the timer in gated mode: Write `TIM_SMS = 101` in the `TIMx_SMCR` register.
- Select TI1 as the input source by writing `TIM_TS = 101` in the `TIMx_SMCR` register.
- Enable the counter: Write `TIM_CEN = 1` in the `TIMx_CR1` register. In gated mode, the counter does not start if `TIM_CEN = 0`, regardless of the trigger input level.

The counter starts counting on the internal clock as long as TI1 is low and stops as soon as TI1 becomes high. The `INT_TIMTIF` flag in the `INT_TIMxFLAG` register is set when the counter starts and when it stops. The delay between the rising edge on TI1 and the actual stop of the counter is due to the resynchronization circuit on the TI1 input.

Figure 9.28 shows the counter in gated mode with counting enabled when TI1 is low.

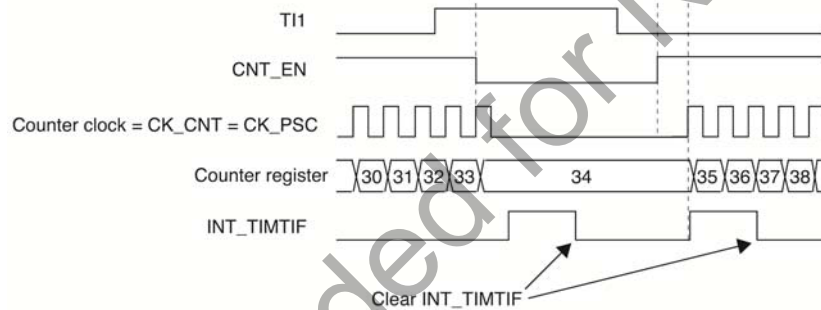

**Figure 9.28. Control Circuit in Gated Mode**

### 9.3.13.3. Slave Mode: Trigger Mode

In trigger mode the counter starts in response to an event on a selected input.

In the following example, the up-counter starts in response to a rising edge on the TI2 input:

- Configure channel 2 to detect rising edges on TI2:
  - Configure the input filter duration. In this example, no filter is required so `TIM_IC2F = 0000`.
  - The capture prescaler is not used for triggering, so it is not configured.
  - The `TIM_CC2S` bits select the input capture source only, `TIM_CC2S = 01` in the `TIMx_CCMR1` register.
  - Write `TIM_CC2P = 0` in the `TIMx_CCER` register to validate the polarity and detect high level only.
- Configure the timer in trigger mode: Write `TIM_SMS = 110` in the `TIMx_SMCR` register.
- Select TI2 as the input source by writing `TIM_TS = 110` in the `TIMx_SMCR` register.

When a rising edge occurs on TI2, the counter starts counting on the internal clock and the `INT_TIMTIF` flag is set. The delay between the rising edge on TI2 and the actual start of the counter is due to the resynchronization circuit on the TI2 input.

Figure 9.29 illustrates the example in which the counter is started by a rising edge on TI2.

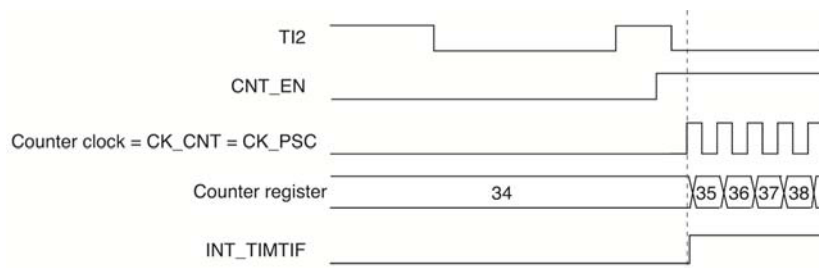

**Figure 9.29. Control Circuit in Trigger Mode**

#### 9.3.13.4. Slave Mode: External Clock Mode 2 + Trigger Mode

External clock mode 2 can be used in combination with another slave mode (except external clock mode 1 and encoder mode). In this case, the ETR signal is used as external clock input, and another input can be selected as trigger input when operating in reset mode, gated mode or trigger mode. It is not recommended to select ETR as TRGI through the TIM\_TS bits of TIMx\_SMCR register.

In the following example (shown in Figure 9.30) the up-counter is incremented at each rising edge of the ETR signal as soon as a rising edge of TI1 occurs:

- Configure the external trigger input circuit: Program the TIMx\_SMCR register as follows:
  - TIM\_ETF = 0000: no filter.
  - TIM\_ETPS = 00: prescaler disabled.
  - TIM\_ETP = 0: detection of rising edges on ETR and TIM\_ECE = 1 to enable the external clock mode 2.
- Configure the channel 1 to detect rising edges on TI, as follows:
  - TIM\_IC1F = 0000: no filter.
  - The capture prescaler is not used for triggering and does not need to be configured.
  - TIM\_CC1S = 01 in the TIMx\_CCMR1 register to select only the input capture source.
  - TIM\_CC1P = 0 in the TIMx\_CCER register to validate the polarity (and detect rising edge only).
- Configure the timer in trigger mode: Write TIM\_SMS = 110 in the TIMx\_SMCR register.
- Select TI1 as the input source by writing TIM\_TS = 101 in the TIMx\_SMCR register.

A rising edge on TI1 enables the counter and sets the INT\_TIMTIF flag. The counter then counts on ETR rising edges. The delay between the rising edge of the ETR signal and the actual reset of the counter is due to the resynchronization circuit on ETRP input.

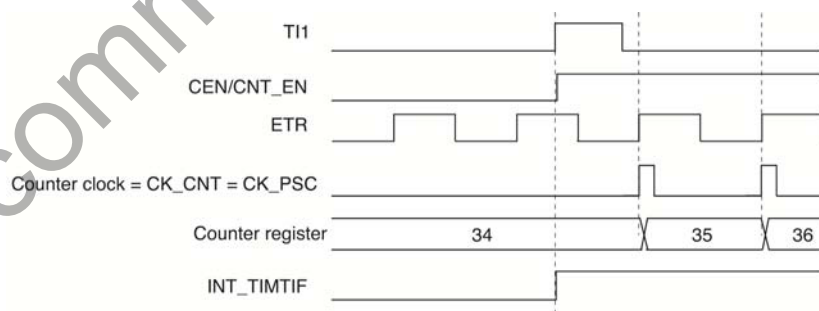

**Figure 9.30. Control Circuit in External Clock Mode 2 + Trigger Mode**



### 9.3.14. Timer Synchronization

The two timers can be linked together internally for timer synchronization or chaining. A timer configured in master mode can reset, start, stop or clock the counter of the other timer configured in slave mode.

Figure 9.31 presents an overview of the trigger selection and the master mode selection blocks.

#### 9.3.14.1. Using One Timer as Prescaler for the Other Timer

For example, to configure Timer 1 to act as a prescaler for Timer 2:

- Configure Timer 1 in master mode so that it outputs a periodic trigger signal on each UEV. Writing TIM\_MMS = 010 in the TIM1\_CR2 register causes a rising edge to be output on TRGO each time a UEV is generated.
- To connect the TRGO output of Timer 1 to Timer 2, configure Timer 2 in slave mode using ITR0 as an internal trigger. Write TIM\_TS = 100 in the TIM2\_SMCR register.
- Put the slave mode controller in external clock mode 1: Write TIM\_SMS = 111 in the TIM2\_SMCR register. This causes Timer 2 to be clocked by the rising edge of the periodic Timer 1 trigger signal, which corresponds to the Timer 1 counter overflow.
- Finally, enable both timers: Set their respective TIM\_CEN bits in the TIMx\_CR1 register.

**Note:** If OCy is selected on Timer 1 as trigger output (TIM\_MMS = 1xx), its rising edge is used to clock the counter of Timer 2.

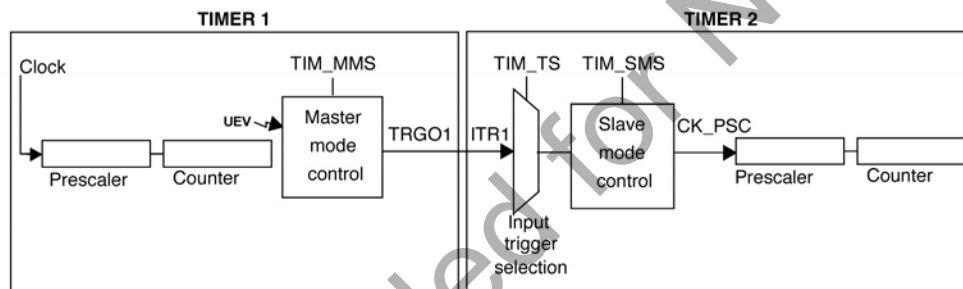

Figure 9.31. Master/Slave Timer Example

### 9.3.14.2. Using One Timer to Enable the Other Timer

In this example, shown in Figure 9.32, the enable of Timer 2 is controlled with the output compare 1 of Timer 1. Timer 2 counts on the divided internal clock only when OC1REF of Timer 1 is high. Both counter clock frequencies are divided by 3 by the prescaler compared to CK\_INT ( $f_{CK\_CNT} = f_{CK\_INT} / 3$ ).

- Configure Timer 1 in master mode to send its Output Compare Reference (OC1REF) signal as trigger output: Write TIM\_MMS = 100 in the TIM1\_CR2 register.
- Configure the Timer 1 OC1REF waveform (TIM1\_CCMR1 register).
- Configure Timer 2 to get the input trigger from Timer 1: Write TIM\_TS = 000 in the TIM2\_SMCR register.
- Configure Timer 2 in gated mode: Write TIM\_SMS = 101 in the TIM2\_SMCR register.
- Enable Timer 2: Write 1 in the TIM\_CEN bit in the TIM2\_CR1 register.
- Start Timer 1: Write 1 in the TIM\_CEN bit in the TIM1\_CR1 register.

**Note:** The counter 2 clock is not synchronized with counter 1, this mode only affects the Timer 2 counter enable signal.

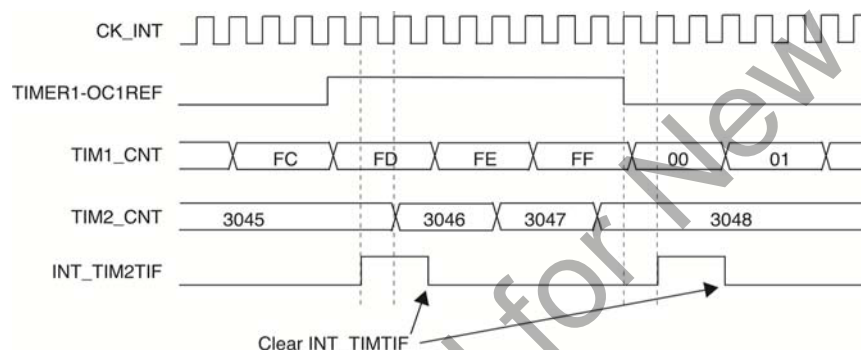
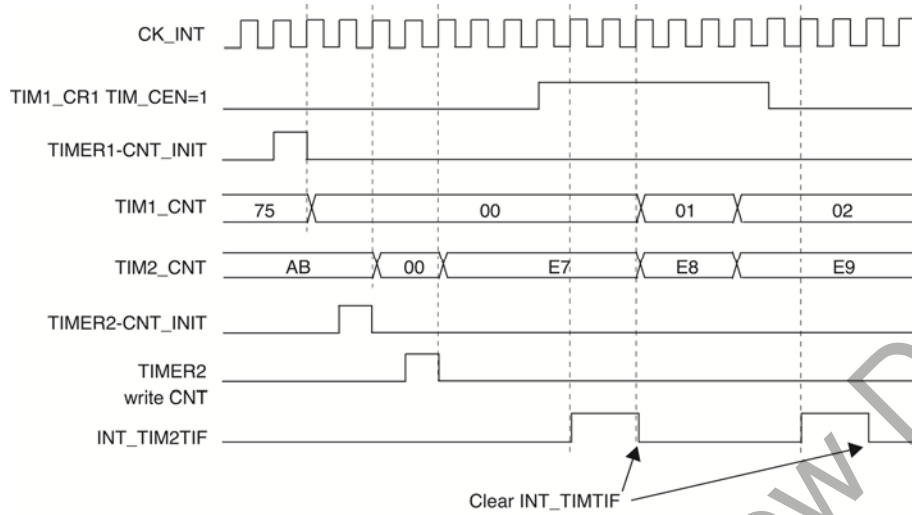

**Figure 9.32. Gating Timer 2 with OC1REF of Timer 1**

In the example in Figure 9.32, the Timer 2 counter and prescaler are not initialized before being started. So they start counting from their current value. It is possible to start from a given value by resetting both timers before starting Timer 1, then writing the desired value in the timer counters. The timers can easily be reset by software using the TIM\_UG bit in the TIMx\_EGR registers.

The next example, shown in Figure 9.33, synchronizes Timer 1 and Timer 2. Timer 1 is the master and starts from 0. Timer 2 is the slave and starts from 0xE7. The prescaler ratio is the same for both timers. Timer 2 stops when Timer 1 is disabled by writing 0 to the TIM\_CEN bit in the TIM1\_CR1 register:

- Configure Timer 1 in master mode to send its Output Compare Reference (OC1REF) signal as trigger output: Write TIM\_MMS = 100 in the TIM1\_CR2 register)
- Configure the Timer 1 OC1REF waveform (TIM1\_CCMR1 register).
- Configure Timer 2 to get the input trigger from Timer 1: Write TIM\_TS = 000 in the TIM2\_SMCR register.
- Configure Timer 2 in gated mode: Write TIM\_SMS = 101 in the TIM2\_SMCR register.
- Reset Timer 1: Write 1 in the TIM\_UG bit (TIM1\_EGR register).
- Reset Timer 2 by writing 1 in the TIM\_UG bit (TIM2\_EGR register).
- Initialize Timer 2 to 0xE7: Write 0xE7 in the Timer 2 counter (TIM2\_CNT).
- Enable Timer 2: Write 1 in the TIM\_CEN bit in the TIM2\_CR1 register.
- Start Timer 1: Write 1 in the TIM\_CEN bit in the TIM1\_CR1 register.
- Stop Timer 1: Write 0 in the TIM\_CEN bit in the TIM1\_CR1 register.



**Figure 9.33. Gating Timer 2 with Enable of Timer 1**

### 9.3.14.3. Using One Timer to Start the Other Timer

In this example (see Figure 9.34), the enable of Timer 2 is set with the UEV of Timer 1. Timer 2 starts counting from its current value (which can be non-zero) on the divided internal clock as soon as Timer 1 generates the UEV.

When Timer 2 receives the trigger signal its TIM\_CEN bit is automatically set and the counter counts until 0 is written to the TIM\_CEN bit in the TIM2\_CR1 register. Both counter clock frequencies are divided by 3 by the prescaler compared to CK\_INT ( $f_{CK\_CNT} = f_{CK\_INT}/3$ ).

- Configure Timer 1 in master mode to send its UEV as trigger output: Write TIM\_MMS = 010 in the TIM1\_CR2 register.
- Configure the Timer 1 period (TIM1\_ARR register).
- Configure Timer 2 to get the input trigger from Timer 1: Write TIM\_TS = 000 in the TIM2\_SMCR register.
- Configure Timer 2 in trigger mode. Write TIM\_SMS = 110 in the TIM2\_SMCR register.
- Start Timer 1: Write 1 in the TIM\_CEN bit in the TIM1\_CR1 register.

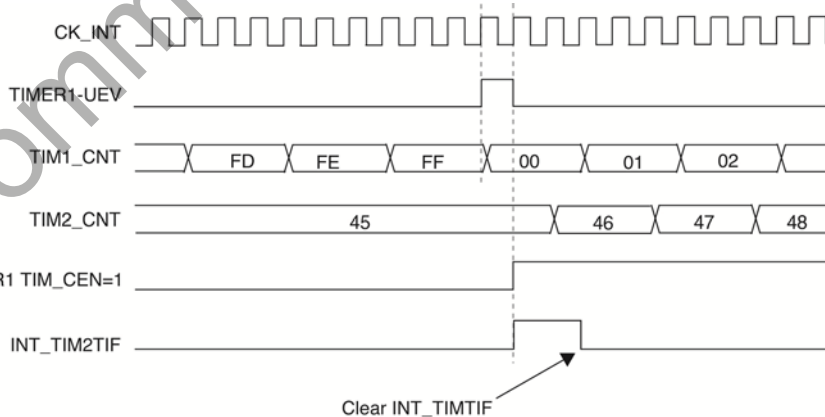

**Figure 9.34. Triggering Timer 2 with Update of Timer 1**

As in the previous example, both counters can be initialized before starting counting. Figure 9.35 shows the behavior with the same configuration shown in Figure 9.34, but in trigger mode instead of gated mode (TIM\_SMS = 110 in the TIM2\_SMCR register).

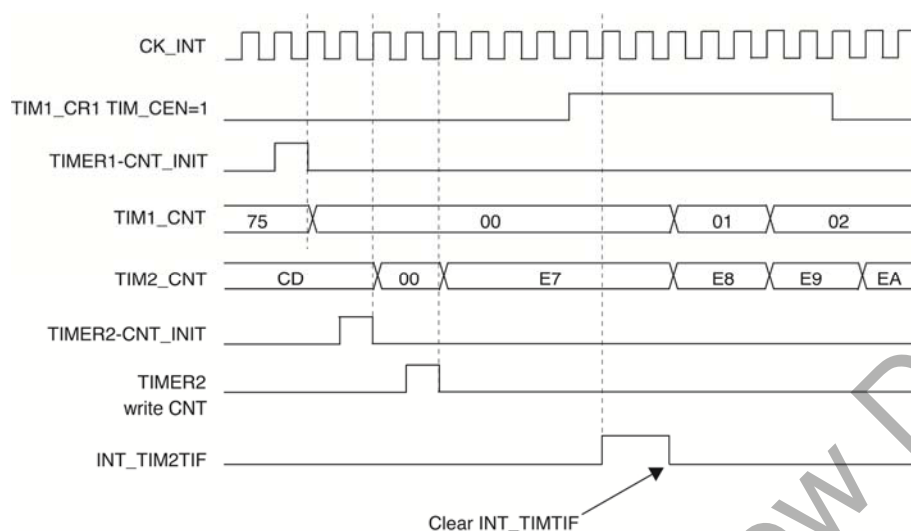

**Figure 9.35. Triggering Timer 2 with Enable of Timer 1**

#### 9.3.14.4. Starting both Timers Synchronously in Response to an External Trigger

This example sets the enable of Timer 1 when its TI1 input rises, and the enable of Timer 2 with the enable of Timer 1. To ensure the counters are aligned, Timer 1 must be configured in master/slave mode (slave with respect to TI1, master with respect to Timer 2):

- Configure Timer 1 in master mode to send its Enable as trigger output: Write `TIM_MMS = 001` in the `TIM1_CR2` register.
- Configure Timer 1 slave mode to get the input trigger from TI1: Write `TIM_TS = 100` in the `TIM1_SMCR` register.
- Configure Timer 1 in trigger mode: Write `TIM_SMS = 110` in the `TIM1_SMCR` register.
- Configure the Timer 1 in master/slave mode: Write `TIM_MSM = 1` in the `TIM1_SMCR` register.
- Configure Timer 2 to get the input trigger from Timer 1: Write `TIM_TS = 000` in the `TIM2_SMCR` register.
- Configure Timer 2 in trigger mode: Write `TIM_SMS = 110` in the `TIM2_SMCR` register.

When a rising edge occurs on TI1 (Timer 1), both counters start counting synchronously on the internal clock and both timers' `INT_TIM2TIF` flags are set. Figure 9.36 shows this in operation.

**Note:** In this example both timers are initialized before starting by setting their respective `TIM_UG` bits. Both counters start from 0, but an offset can be inserted between them by writing any of the counter registers (`TIMx_CNT`). The master/slave mode inserts a delay between `CNT_EN` and `CK_PSC` on Timer 1.

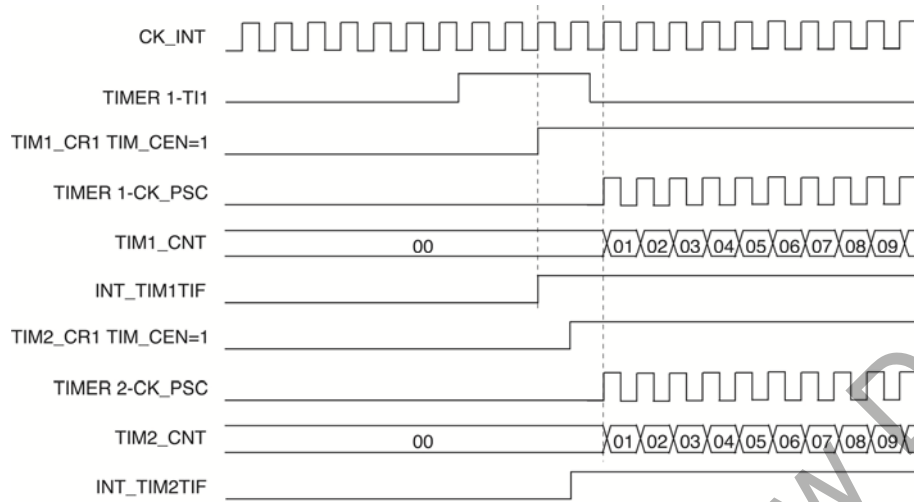

**Figure 9.36. Triggering Timer 1 and 2 with Timer 1 TI1 Input**

### 9.3.15. Timer Signal Descriptions

**Table 9.4. Timer Signal Descriptions**

Signal	Internal/ External	Description
CK_INT	Internal	Internal clock source: connects to EM341 peripheral clock (PCLK) in internal clock mode.
CK_PSC	Internal	Input to the clock prescaler.
ETR	Internal	External trigger input (used in external timer mode 2): a clock selected by TIM_EXTRIGSEL in TIMx_OR.
ETRF	Internal	External trigger: ETRP after filtering.
ETRP	Internal	External trigger: ETR after polarity selection, edge detection and prescaling.
ICy	External	Input capture or clock: TIy after filtering and edge detection.
ICyPS	Internal	Input capture signal after filtering, edge detection and prescaling: input to the capture register.
ITR0	Internal	Internal trigger input: connected to the other timer's output, TRGO.
OCy	External	Output compare: TIMxCy when used as an output. Same as OCyREF but includes possible polarity inversion.
OCyREF	Internal	Output compare reference: always active high, but may be inverted to produce OCy.
PCLK	External	Peripheral clock connects to CK_INT and used to clock input filtering. Its frequency is 12 MHz if using the 24 MHz crystal oscillator and 6 MHz if using the 12 MHz RC oscillator.
Tly	Internal	Timer input: TIMxCy when used as a timer input.
TlyFPy	Internal	Timer input after filtering and polarity selection.
TIMxCy	Internal	Timer channel at a GPIO pin: can be a capture input (ICy) or a compare output (OCy).
TIMxCLK	External	Clock input (if selected) to the external trigger signal (ETR).
TIMxMSK	External	Clock mask (if enabled) AND'ed with the other timer's TIMxCLK signal.
TRGI	Internal	Trigger input for slave mode controller.

## 9.4. Interrupts

Each timer has its own top-level NVIC interrupt. Writing 1 to the INT\_TIMx bit in the INT\_CFGSET register enables the TIMx interrupt, and writing 1 to the INT\_TIMx bit in the INT\_CFGCLR register disables it. "9. Interrupt System" on page 100 describes the interrupt system in detail.

Several kinds of timer events can generate a timer interrupt, and each has a status flag in the INT\_TIMxFLAG register to identify the reason(s) for the interrupt:

- INT\_TIMTIF – set by a rising edge on an external trigger, either edge in gated mode
- INT\_TIMCCRYIF – set by a channel y input capture or output compare event
- INT\_TIMUIF – set by a UEV

Clear bits in INT\_TIMxFLAG by writing a 1 to their bit position. When a channel is in capture mode, reading the TIMx\_CCRy register will also clear the INT\_TIMCCRYIF bit.

The INT\_TIMxCFG register controls whether or not the INT\_TIMxFLAG bits actually request a top-level NVIC timer interrupt. Only the events whose bits are set to 1 in INT\_TIMxCFG can do so.

If an input capture or output compare event occurs and its INT\_TIMMISSCYIF is already set, the corresponding capture/compare missed flag is set in the INT\_TMRxMISS register. Clear a bit in the INT\_TMRxMISS register by writing a 1 to it.

# EM341

## 9.5. Registers

**Note:** Substitute “1” or “2” for “x” in the following detailed descriptions.

### Register 9.1. TIMx\_CR1

TIM1\_CR1: Timer 1 Control Register 1

TIM2\_CR1: Timer 2 Control Register 1

Bit	31	30	29	28	27	26	25	24
Name	0	0	0	0	0	0	0	0
Bit	23	22	21	20	19	18	17	16
Name	0	0	0	0	0	0	0	0
Bit	15	14	13	12	11	10	9	8
Name	0	0	0	0	0	0	0	0
Bit	7	6	5	4	3	2	1	0
Name	TIM_ARBE	TIM_CMS		TIM_DIR	TIM_OPM	TIM_URS	TIM_UDIS	TIM_CEN

TIM1\_CR1: Address: 0x4000E000 Reset: 0x0

TIM2\_CR1: Address: 0x4000F000 Reset: 0x0

Bitname	Bitfield	Access	Description
TIM_ARBE	[7]	RW	Auto-Reload Buffer Enable. 0: TIMx_ARR register is not buffered. 1: TIMx_ARR register is buffered.
TIM_CMS	[6:5]	RW	Center-aligned Mode Selection. 00: Edge-aligned mode. The counter counts up or down depending on the direction bit (TIM_DIR). 01: Center-aligned mode 1. The counter counts up and down alternatively. Output compare interrupt flags of configured output channels (TIM_CCyS=00 in TIMx_CCMRy register) are set only when the counter is counting down. 10: Center-aligned mode 2. The counter counts up and down alternatively. Output compare interrupt flags of configured output channels (TIM_CCyS=00 in TIMx_CCMRy register) are set only when the counter is counting up. 11: Center-aligned mode 3. The counter counts up and down alternatively. Output compare interrupt flags of configured output channels (TIM_CCyS=00 in TIMx_CCMRy register) are set both when the counter is counting up or down.  <b>Note:</b> Software may not switch from edge-aligned mode to center-aligned mode when the counter is enabled (TIM_CEN = 1).
TIM_DIR	[4]	RW	Direction. 0: Counter used as up-counter. 1: Counter used as down-counter.
TIM_OPM	[3]	RW	One Pulse Mode. 0: Counter does not stop counting at the next UEV. 1: Counter stops counting at the next UEV (and clears the bit TIM_CEN).

Bitname	Bitfield	Access	Description
TIM_URS	[2]	RW	Update Request Source. 0: When enabled, update interrupt requests are sent as soon as registers are updated (counter overflow/underflow, setting the TIM_UG bit, or update generation through the slave mode controller). 1: When enabled, update interrupt requests are sent only when the counter reaches overflow or underflow.
TIM_UDIS	[1]	RW	Update Disable. 0: A UEV is generated as soon as a counter overflow occurs, a software update is generated, or a hardware reset is generated by the slave mode controller. Shadow registers are then loaded with their buffer register values. 1: A UEV is not generated and shadow registers keep their value (TIMx_ARR, TIMx_PSC, TIMx_CCRy). The counter and the prescaler are reinitialized if the TIM_UG bit is set or if a hardware reset is received from the slave mode controller.
TIM_CEN	[0]	RW	Counter Enable. 0: Counter disabled. 1: Counter enabled.  Note: External clock, gated mode and encoder mode can work only if the TIM_CEN bit has been previously set by software. Trigger mode sets the TIM_CEN bit automatically through hardware.



# EM341

## Register 9.2. TIMx\_CR2

TIM1\_CR2: Timer 1 Control Register 2

TIM2\_CR2: Timer 2 Control Register 2

Bit	31	30	29	28	27	26	25	24
Name	0	0	0	0	0	0	0	0
Bit	23	22	21	20	19	18	17	16
Name	0	0	0	0	0	0	0	0
Bit	15	14	13	12	11	10	9	8
Name	0	0	0	0	0	0	0	0
Bit	7	6	5	4	3	2	1	0
Name	TIM_TI1S	TIM_MMS			0	0	0	0

TIM1\_CR2: Address: 0x4000E004 Reset: 0x0

TIM2\_CR2: Address: 0x4000F004 Reset: 0x0

Bitname	Bitfield	Access	Description
TIM_TI1S	[7]	RW	TI1 Selection. 0: TI1M (input of the digital filter) is connected to TI1 input. 1: TI1M is connected to the TI_HALL inputs (XOR combination).
TIM_MMS	[6:4]	RW	Master Mode Selection. This selects the information to be sent in master mode to a slave timer for synchronization using the trigger output (TRGO). 000: Reset - the TIM_UG bit in the TMRx_EGR register is trigger output. If the reset is generated by the trigger input (slave mode controller configured in reset mode), then the signal on TRGO is delayed compared to the actual reset. 001: Enable - counter enable signal CNT_EN is trigger output. This mode is used to start both timers at the same time or to control a window in which a slave timer is enabled. The counter enable signal is generated by either the TIM_CEN control bit or the trigger input when configured in gated mode. When the counter enable signal is controlled by the trigger input there is a delay on TRGO except if the master/slave mode is selected (see the TIM_MSM bit description in TMRx_SMCR register). 010: Update - UEV is trigger output. This mode allows a master timer to be a prescaler for a slave timer. 011: Compare Pulse. The trigger output sends a positive pulse when the TIM_CC1IF flag is to be set (even if it was already high) as soon as a capture or a compare match occurs. 100: Compare - OC1REF signal is trigger output. 101: Compare - OC2REF signal is trigger output. 110: Compare - OC3REF signal is trigger output. 111: Compare - OC4REF signal is trigger output.

**Register 9.3. TIMx\_SMCR****TIM1\_SMCR: Timer 1 Slave Mode Control Register****TIM2\_SMCR: Timer 2 Slave Mode Control Register**

<b>Bit</b>	<b>31</b>	<b>30</b>	<b>29</b>	<b>28</b>	<b>27</b>	<b>26</b>	<b>25</b>	<b>24</b>
<b>Name</b>	0	0	0	0	0	0	0	0
<b>Bit</b>	<b>23</b>	<b>22</b>	<b>21</b>	<b>20</b>	<b>19</b>	<b>18</b>	<b>17</b>	<b>16</b>
<b>Name</b>	0	0	0	0	0	0	0	0
<b>Bit</b>	<b>15</b>	<b>14</b>	<b>13</b>	<b>12</b>	<b>11</b>	<b>10</b>	<b>9</b>	<b>8</b>
<b>Name</b>	TIM_ETP	TIM_ECE	TIM_ETPS		TIM_ETF			
<b>Bit</b>	<b>7</b>	<b>6</b>	<b>5</b>	<b>4</b>	<b>3</b>	<b>2</b>	<b>1</b>	<b>0</b>
<b>Name</b>	TIM_MSM	TIM_TS		0		TIM_SMS		

TIM1\_SMCR: Address: 0x4000E008 Reset: 0x0

TIM2\_SMCR: Address: 0x4000F008 Reset: 0x0

<b>Bitname</b>	<b>Bitfield</b>	<b>Access</b>	<b>Description</b>
TIM_ETP	[15]	RW	External Trigger Polarity. This bit selects whether ETR or the inverse of ETR is used for trigger operations. 0: ETR is non-inverted, active at a high level or rising edge. 1: ETR is inverted, active at a low level or falling edge.
TIM_ECE	[14]	RW	External Clock Enable. This bit enables external clock mode 2. 0: External clock mode 2 disabled. 1: External clock mode 2 enabled. The counter is clocked by any active edge on the ETRF signal. <b>Notes:</b> 1. Setting the TIM_ECE bit has the same effect as selecting external clock mode 1 with TRGI connected to ETRF (TIM_SMS=111 and TIM_TS=111). 2. It is possible to use this mode simultaneously with the following slave modes: reset mode, gated mode and trigger mode. TRGI must not be connected to ETRF in this case (the TIM_TS bits must not be 111). 3. If external clock mode 1 and external clock mode 2 are enabled at the same time, the external clock input will be ETRF.
TIM_ETPS	[13:12]	RW	External Trigger Prescaler. External trigger signal ETRP frequency must be at most 1/4 of CK frequency. A prescaler can be enabled to reduce ETRP frequency. It is useful with fast external clocks. 00: ETRP prescaler off. 01: Divide ETRP frequency by 2. 10: Divide ETRP frequency by 4. 11: Divide ETRP frequency by 8.

# EM341

Bitname	Bitfield	Access	Description
TIM_ETF	[11:8]	RW	<p>External Trigger Filter.</p> <p>This defines the frequency used to sample the ETRP signal, Fsampling, and the length of the digital filter applied to ETRP. The digital filter is made of an event counter in which N events are needed to validate a transition on the output:</p> <p>0000: Fsampling = PCLK, no filtering.            0001: Fsampling = PCLK, N = 2.            0010: Fsampling = PCLK, N = 4.            0011: Fsampling = PCLK, N = 8.            0100: Fsampling = PCLK/2, N = 6.            0101: Fsampling = PCLK/2, N = 8.            0110: Fsampling = PCLK/4, N = 6.            0111: Fsampling = PCLK/4, N = 8.            1000: Fsampling = PCLK/8, N = 6.            1001: Fsampling = PCLK/8, N = 8.            1010: Fsampling = PCLK/16, N = 5.            1011: Fsampling = PCLK/16, N = 6.            1100: Fsampling = PCLK/16, N = 8.            1101: Fsampling = PCLK/32, N = 5.            1110: Fsampling = PCLK/32, N = 6.            1111: Fsampling = PCLK/32, N = 8.</p> <p><b>Note:</b> PCLK is 12 MHz when the EM341 is using the 24 MHz crystal oscillator, and 6 MHz if using the 12 MHz RC oscillator.</p>
TIM_MSM	[7]	RW	<p>Master/Slave Mode.</p> <p>0: No action.            1: The effect of an event on the trigger input (TRGI) is delayed to allow exact synchronization between the current timer and the slave (through TRGO). It is useful for synchronizing timers on a single external event.</p>
TIM_TS	[6:4]	RW	<p>Trigger Selection.</p> <p>This bit field selects the trigger input used to synchronize the counter.</p> <p>000 : Internal Trigger 0 (ITR0).            100 : TI1 Edge Detector (TI1F_ED).            101 : Filtered Timer Input 1 (TI1FP1).            110 : Filtered Timer Input 2 (TI2FP2).            111 : External Trigger input (ETRF).</p> <p><b>Note:</b> These bits must be changed only when they are not used (when TIM_SMS = 000) to avoid detecting spurious edges during the transition.</p>

Bitname	Bitfield	Access	Description
TIM_SMS	[2:0]	RW	<p>Slave Mode Selection.</p> <p>When external signals are selected the active edge of the trigger signal (TRGI) is linked to the polarity selected on the external input.</p> <p>000: Slave mode disabled.</p> <p>If TIM_CEN = 1 then the prescaler is clocked directly by the internal clock.</p> <p>001: Encoder mode 1. Counter counts up/down on TI1FP1 edge depending on TI2FP2 level.</p> <p>010: Encoder mode 2. Counter counts up/down on TI2FP2 edge depending on TI1FP1 level.</p> <p>011: Encoder mode 3. Counter counts up/down on both TI1FP1 and TI2FP2 edges depending on the level of the other input.</p> <p>100: Reset Mode. Rising edge of the selected trigger signal (TRGI) &gt;reinitializes the counter and generates an update of the registers.</p> <p>101: Gated Mode. The counter clock is enabled when the trigger signal (TRGI) is high. The counter stops (but is not reset) as soon as the trigger becomes low. Both starting and stopping the counter are controlled.</p> <p>110: Trigger Mode. The counter starts at a rising edge of the trigger TRGI (but it is not reset). Only starting the counter is controlled.</p> <p>111: External Clock Mode 1. Rising edges of the selected trigger (TRGI) clock the counter.</p> <p><b>Note:</b> Gated mode must not be used if TI1F_ED is selected as the trigger input (TIM_TS = 100). TI1F_ED outputs 1 pulse for each transition on TI1F, whereas gated mode checks the level of the trigger signal.</p>

# EM341

## Register 9.4. TIMx\_EGR

TIM1\_EGR: Timer 1 Event Generation Register

TIM2\_EGR: Timer 2 Event Generation Register

<b>Bit</b>	<b>31</b>	<b>30</b>	<b>29</b>	<b>28</b>	<b>27</b>	<b>26</b>	<b>25</b>	<b>24</b>
<b>Name</b>	0	0	0	0	0	0	0	0
<b>Bit</b>	<b>23</b>	<b>22</b>	<b>21</b>	<b>20</b>	<b>19</b>	<b>18</b>	<b>17</b>	<b>16</b>
<b>Name</b>	0	0	0	0	0	0	0	0
<b>Bit</b>	<b>15</b>	<b>14</b>	<b>13</b>	<b>12</b>	<b>11</b>	<b>10</b>	<b>9</b>	<b>8</b>
<b>Name</b>	0	0	0	0	0	0	0	0
<b>Bit</b>	<b>7</b>	<b>6</b>	<b>5</b>	<b>4</b>	<b>3</b>	<b>2</b>	<b>1</b>	<b>0</b>
<b>Name</b>	0	TIM_TG	0	TIM_CC4G	TIM_CC3G	TIM_CC2G	TIM_CC1G	TIM_UG

TIM1\_EGR: Address: 0x4000E014 Reset: 0x0

TIM2\_EGR: Address: 0x4000F014 Reset: 0x0

Bitname	Bitfield	Access	Description
TIM_TG	[6]	W	Trigger Generation. 0: Does nothing. 1: Sets the TIM_TIF flag in the INT_TIMxFLAG register.
TIM_CC4G	[4]	W	Capture/Compare 4 Generation. 0: Does nothing. 1: If CC4 configured as output channel: The TIM_CC4IF flag is set. If CC4 configured as input channel: The TIM_CC4IF flag is set. The INT_TIMMISSCC4IF flag is set if the TIM_CC4IF flag was already high. The current value of the counter is captured in TMRx_CCR4 register.
TIM_CC3G	[3]	W	Capture/Compare 3 Generation. 0: Does nothing. 1: If CC3 configured as output channel: The TIM_CC3IF flag is set. If CC3 configured as input channel: The TIM_CC3IF flag is set. The INT_TIMMISSCC3IF flag is set if the TIM_CC3IF flag was already high. The current value of the counter is captured in TMRx_CCR3 register.

Bitname	Bitfield	Access	Description
TIM_CC2G	[2]	W	<p>Capture/Compare 2 Generation.</p> <p>0: Does nothing.</p> <p>1: If CC2 configured as output channel: The TIM_CC2IF flag is set.</p> <p>If CC2 configured as input channel: The TIM_CC2IF flag is set. The INT_TIMMISSCC2IF flag is set if the TIM_CC2IF flag was already high. The current value of the counter is captured in TMRx_CCR2 register.</p>
TIM_CC1G	[1]	W	<p>Capture/Compare 1 Generation.</p> <p>0: Does nothing.</p> <p>1: If CC1 configured as output channel: The TIM_CC1IF flag is set.</p> <p>If CC1 configured as input channel: The TIM_CC1IF flag is set. The INT_TIMMISSCC1IF flag is set if the TIM_CC1IF flag was already high. The current value of the counter is captured in TMRx_CCR1 register.</p>
TIM_UG	[0]	W	<p>Update Generation.</p> <p>0: Does nothing.</p> <p>1: Re-initializes the counter and generates an update of the registers. This also clears the prescaler counter but the prescaler ratio is not affected. The counter is cleared if center-aligned mode is selected or if TIM_DIR=0 (up-counting), otherwise it takes the auto-reload value (TMR1_ARR) if TIM_DIR=1 (down-counting).</p>

# EM341

## Register 9.5. TIMx\_CCMR1

TIM1\_CCMR1: Timer 1 Capture/Compare Mode Register 1

TIM2\_CCMR1: Timer 2 Capture/Compare Mode Register 1

<b>Bit</b>	<b>31</b>	<b>30</b>	<b>29</b>	<b>28</b>	<b>27</b>	<b>26</b>	<b>25</b>	<b>24</b>
<b>Name</b>	0	0	0	0	0	0	0	0
<b>Bit</b>	<b>23</b>	<b>22</b>	<b>21</b>	<b>20</b>	<b>19</b>	<b>18</b>	<b>17</b>	<b>16</b>
<b>Name</b>	0	0	0	0	0	0	0	0
<b>Bit</b>	<b>15</b>	<b>14</b>	<b>13</b>	<b>12</b>	<b>11</b>	<b>10</b>	<b>9</b>	<b>8</b>
<b>Name</b>	0	TIM_OC2M			TIM_OC2BE	TIM_OC2FE	TIM_CC2S	
	TIM_IC2F				TIM_IC2PSC			
<b>Bit</b>	<b>7</b>	<b>6</b>	<b>5</b>	<b>4</b>	<b>3</b>	<b>2</b>	<b>1</b>	<b>0</b>
<b>Name</b>	0	TIM_OC1M			TIM_OC1BE	TIM_OC1FE	TIM_CC1S	
	TIM_IC1F				TIM_IC1PSC			

TIM1\_CCMR1: Address: 0x4000E018 Reset: 0x0

TIM2\_CCMR1: Address: 0x4000F018 Reset: 0x0

Timer channels can be programmed as inputs (capture mode) or outputs (compare mode). The direction of channel y is defined by TIM\_CCyS in this register.

The other bits in this register have different functions in input and in output modes. The TIM\_OC\* fields only apply to a channel configured as an output (TIM\_CCyS = 0), and the TIM\_IC\* fields only apply to a channel configured as an input (TIM\_CCyS > 0).

Bitname	Bitfield	Access	Description
TIM_OC2M	[14:12]	RW	<p>Output Compare 2 Mode. (Applies only if TIM_CC2S = 0.)</p> <p>Define the behavior of the output reference signal OC2REF from which OC2 derives. OC2REF is active high whereas OC2's active level depends on the TIM_CC2P bit.</p> <p>000: Frozen - The comparison between the output compare register TIMx_CCR2 and the counter TIMx_CNT has no effect on the outputs.</p> <p>001: Set OC2REF to active on match. The OC2REF signal is forced high when the counter TIMx_CNT matches the capture/compare register 2 (TIMx_CCR2)</p> <p>010: Set OC2REF to inactive on match. OC2REF signal is forced low when the counter TIMx_CNT matches the capture/compare register 2 (TIMx_CCR2).</p> <p>011: Toggle - OC2REF toggles when TIMx_CNT = TIMx_CCR2.</p> <p>100: Force OC2REF inactive.</p> <p>101: Force OC2REF active.</p> <p>110: PWM mode 1 - In up-counting, OC2REF is active as long as TIMx_CNT &lt; TIMx_CCR2, otherwise OC2REF is inactive. In down-counting, OC2REF is inactive if TIMx_CNT &gt; TIMx_CCR2, otherwise OC2REF is active.</p> <p>111: PWM mode 2 - In up-counting, OC2REF is inactive if TIMx_CNT &lt; TIMx_CCR2, otherwise OC2REF is active. In down-counting, OC2REF is active if TIMx_CNT &gt; TIMx_CCR2, otherwise it is inactive.</p> <p><b>Note:</b> In PWM mode 1 or 2, the OC2REF level changes only when the result of the comparison changes or when the output compare mode switches from "frozen" mode to "PWM" mode.</p>
TIM_OC2BE	[11]	RW	<p>Output Compare 2 Buffer Enable. (Applies only if TIM_CC2S = 0.)</p> <p>0: Buffer register for TIMx_CCR2 is disabled. TIMx_CCR2 can be written at anytime, the new value is used by the shadow register immediately.</p> <p>1: Buffer register for TIMx_CCR2 is enabled. Read/write operations access the buffer register. TIMx_CCR2 buffer value is loaded in the shadow register at each UEV.</p> <p><b>Note:</b> The PWM mode can be used without enabling the buffer register only in one pulse mode (TIM_OPM bit set in the TIMx_CR2 register), otherwise the behavior is undefined.</p>
TIM_OC2FE	[10]	RW	<p>Output Compare 2 Fast Enable. (Applies only if TIM_CC2S = 0.)</p> <p>This bit speeds the effect of an event on the trigger in input on the OC2 output.</p> <p>0: OC2 behaves normally depending on the counter and TIM_CCR2 values even when the trigger is ON. The minimum delay to activate OC2 when an edge occurs on the trigger input is 5 clock cycles.</p> <p>1: An active edge on the trigger input acts like a compare match on the OC2 output. OC2 is set to the compare level independently from the result of the comparison. Delay to sample the trigger input and to activate OC2 output is reduced to 3 clock cycles. TIM_OC2FE acts only if the channel is configured in PWM 1 or PWM 2 mode.</p>



# EM341

Bitname	Bitfield	Access	Description
TIM_IC2F	[15:12]	RW	<p>Input Capture 1 Filter. (Applies only if TIM_CC2S &gt; 0.)</p> <p>This defines the frequency used to sample the TI2 input, Fsampling, and the length of the digital filter applied to TI2. The digital filter requires N consecutive samples in the same state before being output.</p> <p>0000: Fsampling = PCLK, no filtering.            0001: Fsampling = PCLK, N = 2.            0010: Fsampling = PCLK, N = 4.            0011: Fsampling = PCLK, N = 8.            0100: Fsampling = PCLK/2, N = 6.            0101: Fsampling = PCLK/2, N = 8.            0110: Fsampling = PCLK/4, N = 6.            0111: Fsampling = PCLK/4, N = 8.            1000: Fsampling = PCLK/8, N = 6.            1001: Fsampling = PCLK/8, N = 8.            1010: Fsampling = PCLK/16, N = 5.            1011: Fsampling = PCLK/16, N = 6.            1100: Fsampling = PCLK/16, N = 8.            1101: Fsampling = PCLK/32, N = 5.            1110: Fsampling = PCLK/32, N = 6.            1111: Fsampling = PCLK/32, N = 8.</p> <p><b>Note:</b> PCLK is 12 MHz when using the 24 MHz crystal oscillator, and 6 MHz using the 12 MHz RC oscillator.</p>
TIM_IC2PSC	[11:10]	RW	<p>Input Capture 1 Prescaler. (Applies only if TIM_CC2S &gt; 0.)</p> <p>00: No prescaling, capture each time an edge is detected on the capture input.            01: Capture once every 2 events.            10: Capture once every 4 events.            11: Capture once every 8 events.</p>
TIM_CC2S	[9:8]	RW	<p>Capture / Compare 2 Selection.</p> <p>This configures the channel as an output or an input. If an input, it selects the input source.</p> <p>00: Channel is an output.            01: Channel is an input and is mapped to TI2.            10: Channel is an input and is mapped to TI1.            11: Channel is an input and is mapped to TRGI. This mode requires an internal trigger input selected by the TIM_TS bit in the TIMx_SMCR register.</p> <p><b>Note:</b> TIM_CC2S may be written only when the channel is off (TIM_CC2E = 0 in the TIMx_CCER register).</p>
TIM_OC1M	[6:4]	RW	<p>Output Compare 1 Mode. (Applies only if TIM_CC1S = 0.)</p> <p>See TIM_OC2M description above.</p>
TIM_OC1BE	[3]	RW	<p>Output Compare 1 Buffer Enable. (Applies only if TIM_CC1S = 0.)</p> <p>See TIM_OC2BE description above.</p>
TIM_OC1FE	[2]	RW	<p>Output Compare 1 Fast Enable. (Applies only if TIM_CC1S = 0.)</p> <p>See TIM_OC2FE description above.</p>

Bitname	Bitfield	Access	Description
TIM_IC1F	[7:4]	RW	Input Capture 1 Filter. (Applies only if TIM_CC1S > 0.) See TIM_IC2F description above.
TIM_IC1PSC	[3:2]	RW	Input Capture 1 Prescaler. (Applies only if TIM_CC1S > 0.) See TIM_IC2PSC description above.
TIM_CC1S	[1:0]	RW	<p>Capture / Compare 1 Selection.</p> <p>This configures the channel as an output or an input. If an input, it selects the input source.</p> <p>00: Channel is an output.</p> <p>01: Channel is an input and is mapped to TI1.</p> <p>10: Channel is an input and is mapped to TI2.</p> <p>11: Channel is an input and is mapped to TRGI. This requires an internal trigger input selected by the TIM_TS bit in the TIM_SMCR register.</p> <p><b>Note:</b> TIM_CC1S may be written only when the channel is off (TIM_CC1E = 0 in the TIMx_CCER register).</p>

Not Recommended for New Designs

## Register 9.6. TIMx\_CCMR2

**TIM1\_CCMR2: Timer 1 Capture/Compare Mode Register 2**

**TIM2\_CCMR2: Timer 2 Capture/Compare Mode Register 2**

<b>Bit</b>	<b>31</b>	<b>30</b>	<b>29</b>	<b>28</b>	<b>27</b>	<b>26</b>	<b>25</b>	<b>24</b>
<b>Name</b>	0	0	0	0	0	0	0	0
<b>Bit</b>	<b>23</b>	<b>22</b>	<b>21</b>	<b>20</b>	<b>19</b>	<b>18</b>	<b>17</b>	<b>16</b>
<b>Name</b>	0	0	0	0	0	0	0	0
<b>Bit</b>	<b>15</b>	<b>14</b>	<b>13</b>	<b>12</b>	<b>11</b>	<b>10</b>	<b>9</b>	<b>8</b>
<b>Name</b>	0	TIM_OC4M			TIM_OC4BE	TIM_OC4FE	TIM_CC4S	
	TIM_IC4F				TIM_IC4PSC			
<b>Bit</b>	<b>7</b>	<b>6</b>	<b>5</b>	<b>4</b>	<b>3</b>	<b>2</b>	<b>1</b>	<b>0</b>
<b>Name</b>	0	TIM_OC3M			TIM_OC3BE	TIM_OC3FE	TIM_CC3S	
	TIM_IC3F				TIM_IC3PSC			

TIM1\_CCMR2: Address: 0x4000E01C Reset: 0x0

TIM2\_CCMR2: Address: 0x4000F01C Reset: 0x0

Timer channels can be programmed as inputs (capture mode) or outputs (compare mode). The direction of channel  $y$  is defined by TIM\_CCyS in this register.

The other bits in this register have different functions in input and in output modes. The TIM\_OC\* fields only apply to a channel configured as an output (TIM\_CCyS = 0), and the TIM\_IC\* fields only apply to a channel configured as an input (TIM\_CCyS > 0).

Bitname	Bitfield	Access	Description
TIM_OC4M	[14:12]	RW	<p>Output Compare 4 Mode. (Applies only if TIM_CC4S = 0.)</p> <p>Define the behavior of the output reference signal OC4REF from which OC4 derives. OC4REF is active high whereas OC4's active level depends on the TIM_CC4P bit.</p> <p>000: Frozen - The comparison between the output compare register TIMx_CCR4 and the counter TIMx_CNT has no effect on the outputs.</p> <p>001: Set OC4REF to active on match. The OC4REF signal is forced high when the counter TIMx_CNT matches the capture/compare register 4 (TIMx_CCR4)</p> <p>010: Set OC4REF to inactive on match. OC4REF signal is forced low when the counter TIMx_CNT matches the capture/compare register 4 (TIMx_CCR4).</p> <p>011: Toggle - OC4REF toggles when TIMx_CNT = TIMx_CCR4.</p> <p>100: Force OC4REF inactive.</p> <p>101: Force OC4REF active.</p> <p>110: PWM mode 1 - In up-counting, OC4REF is active as long as TIMx_CNT &lt; TIMx_CCR4, otherwise OC4REF is inactive. In down-counting, OC4REF is inactive if TIMx_CNT &gt; TIMx_CCR4, otherwise OC4REF is active.</p> <p>111: PWM mode 2 - In up-counting, OC4REF is inactive if TIMx_CNT &lt; TIMx_CCR4, otherwise OC4REF is active. In down-counting, OC4REF is active if TIMx_CNT &gt; TIMx_CCR4, otherwise it is inactive.</p> <p><b>Note:</b> In PWM mode 1 or 2, the OC4REF level changes only when the result of the comparison changes or when the output compare mode switches from "frozen" mode to "PWM" mode.</p>
TIM_OC4BE	[11]	RW	<p>Output Compare 4 Buffer Enable. (Applies only if TIM_CC4S = 0.)</p> <p>0: Buffer register for TIMx_CCR4 is disabled. TIMx_CCR4 can be written at anytime, the new value is used by the shadow register immediately.</p> <p>1: Buffer register for TIMx_CCR4 is enabled. Read/write operations access the buffer register. TIMx_CCR4 buffer value is loaded in the shadow register at each UEV.</p> <p><b>Note:</b> The PWM mode can be used without enabling the buffer register only in one pulse mode (TIM_OPM bit set in the TIMx_CR2 register), otherwise the behavior is undefined.</p>
TIM_OC4FE	[10]	RW	<p>Output Compare 4 Fast Enable. (Applies only if TIM_CC4S = 0.)</p> <p>This bit speeds the effect of an event on the trigger in input on the OC4 output.</p> <p>0: OC4 behaves normally depending on the counter and TIM_CCR4 values even when the trigger is ON. The minimum delay to activate OC4 when an edge occurs on the trigger input is 5 clock cycles.</p> <p>1: An active edge on the trigger input acts like a compare match on the OC4 output. OC4 is set to the compare level independently from the result of the comparison. Delay to sample the trigger input and to activate OC4 output is reduced to 3 clock cycles. TIM_OC4FE acts only if the channel is configured in PWM 1 or PWM 2 mode.</p>

Bitname	Bitfield	Access	Description
TIM_IC4F	[15:12]	RW	<p>Input Capture 4 Filter. (Applies only if TIM_CC4S &gt; 0.)</p> <p>This defines the frequency used to sample the TI4 input, Fsampling, and the length of the digital filter applied to TI4. The digital filter requires N consecutive samples in the same state before being output.</p> <p>0000: Fsampling = PCLK, no filtering.  0001: Fsampling = PCLK, N = 2.  0010: Fsampling = PCLK, N = 4.  0011: Fsampling = PCLK, N = 8.  0100: Fsampling = PCLK/2, N = 6.  0101: Fsampling = PCLK/2, N = 8.  0110: Fsampling = PCLK/4, N = 6.  0111: Fsampling = PCLK/4, N = 8.  1000: Fsampling = PCLK/8, N = 6.  1001: Fsampling = PCLK/8, N = 8.  1010: Fsampling = PCLK/16, N = 5.  1011: Fsampling = PCLK/16, N = 6.  1100: Fsampling = PCLK/16, N = 8.  1101: Fsampling = PCLK/32, N = 5.  1110: Fsampling = PCLK/32, N = 6.  1111: Fsampling = PCLK/32, N = 8.</p> <p><b>Note:</b> PCLK is 12 MHz when using the 24 MHz crystal oscillator, and 6 MHz using the 12 MHz RC oscillator.</p>
TIM_IC4PSC	[11:10]	RW	<p>Input Capture 4 Prescaler. (Applies only if TIM_CC4S &gt; 0.)</p> <p>00: No prescaling, capture each time an edge is detected on the capture input.  01: Capture once every 2 events.  10: Capture once every 4 events.  11: Capture once every 8 events.</p>
TIM_CC4S	[9:8]	RW	<p>Capture / Compare 4 Selection.</p> <p>This configures the channel as an output or an input. If an input, it selects the input source.</p> <p>00: Channel is an output.  01: Channel is an input and is mapped to TI4.  10: Channel is an input and is mapped to TI3.  11: Channel is an input and is mapped to TRGI. This mode requires an internal trigger input selected by the TIM_TS bit in the TIMx_SMCR register.</p> <p><b>Note:</b> TIM_CC4S may be written only when the channel is off (TIM_CC4E = 0 in the TIMx_CCER register).</p>
TIM_OC3M	[6:4]	RW	<p>Output Compare 3 Mode. (Applies only if TIM_CC3S = 0.)</p> <p>See TIM_OC4M description above.</p>
TIM_OC3BE	[3]	RW	<p>Output Compare 3 Buffer Enable. (Applies only if TIM_CC3S = 0.)</p> <p>See TIM_OC4BE description above.</p>
TIM_OC3FE	[2]	RW	<p>Output Compare 3 Fast Enable. (Applies only if TIM_CC3S = 0.)</p> <p>See TIM_OC4FE description above.</p>

Bitname	Bitfield	Access	Description
TIM_IC3F	[7:4]	RW	Input Capture 3 Filter. (Applies only if TIM_CC3S > 0.) See TIM_IC4F description above.
TIM_IC3PSC	[3:2]	RW	Input Capture 3 Prescaler. (Applies only if TIM_CC3S > 0.) See TIM_IC4PSC description above.
TIM_CC3S	[1:0]	RW	<p>Capture / Compare 3 Selection.</p> <p>This configures the channel as an output or an input. If an input, it selects the input source.</p> <p>00: Channel is an output.</p> <p>01: Channel is an input and is mapped to TI3.</p> <p>10: Channel is an input and is mapped to TI4.</p> <p>11: Channel is an input and is mapped to TRGI. This requires an internal trigger input selected by the TIM_TS bit in the TIM_SMCR register.</p> <p><b>Note:</b> TIM_CC3S may be written only when the channel is off (TIM_CC3E = 0 in the TIMx_CCER register).</p>

# EM341

## Register 9.7. TIMx\_CCER

TIM1\_CCER: Timer 1 Capture/Compare Enable Register

TIM2\_CCER: Timer 2 Capture/Compare Enable Register

Bit	31	30	29	28	27	26	25	24
Name	0	0	0	0	0	0	0	0
Bit	23	22	21	20	19	18	17	16
Name	0	0	0	0	0	0	0	0
Bit	15	14	13	12	11	10	9	8
Name	0	0	TIM_CC4P	TIM_CC4E	0	0	TIM_CC3P	TIM_CC3E
Bit	7	6	5	4	3	2	1	0
Name	0	0	TIM_CC2P	TIM_CC2E	0	0	TIM_CC1P	TIM_CC1E

TIM1\_CCER: Address: 0x4000E020 Reset: 0x0

TIM2\_CCER: Address: 0x4000F020 Reset: 0x0

Bitname	Bitfield	Access	Description
TIM_CC4P	[13]	RW	Capture/Compare 4 output Polarity. If CC4 is configured as an output channel: 0: OC4 is active high. 1: OC4 is active low.  If CC4 configured as an input channel: 0: IC4 is not inverted. Capture occurs on a rising edge of IC4. When used as an external trigger, IC4 is not inverted. 1: IC4 is inverted. Capture occurs on a falling edge of IC4. When used as an external trigger, IC4 is inverted.
TIM_CC4E	[12]	RW	Capture/Compare 4 output Enable. If CC4 is configured as an output channel: 0: OC4 is disabled. 1: OC4 is enabled.  If CC4 configured as an input channel: 0: Capture is disabled. 1: Capture is enabled.
TIM_CC3P	[9]	RW	Refer to the CC4P description above.
TIM_CC3E	[8]	RW	Refer to the CC4E description above.
TIM_CC2P	[5]	RW	Refer to the CC4P description above.
TIM_CC2E	[4]	RW	Refer to the CC4E description above.
TIM_CC1P	[1]	RW	Refer to the CC4P description above.
TIM_CC1E	[0]	RW	Refer to the CC4E description above.

**Register 9.8. TIMx\_CNT****TIM1\_CNT: Timer 1 Counter Register****TIM2\_CNT: Timer 2 Counter Register**

<b>Bit</b>	<b>31</b>	<b>30</b>	<b>29</b>	<b>28</b>	<b>27</b>	<b>26</b>	<b>25</b>	<b>24</b>
<b>Name</b>	0	0	0	0	0	0	0	0
<b>Bit</b>	<b>23</b>	<b>22</b>	<b>21</b>	<b>20</b>	<b>19</b>	<b>18</b>	<b>17</b>	<b>16</b>
<b>Name</b>	0	0	0	0	0	0	0	0
<b>Bit</b>	<b>15</b>	<b>14</b>	<b>13</b>	<b>12</b>	<b>11</b>	<b>10</b>	<b>9</b>	<b>8</b>
<b>Name</b>	TIM_CNT							
<b>Bit</b>	<b>7</b>	<b>6</b>	<b>5</b>	<b>4</b>	<b>3</b>	<b>2</b>	<b>1</b>	<b>0</b>
<b>Name</b>	TIM_CNT							

TIM1\_CNT: Address: 0x4000E024 Reset: 0x0

TIM2\_CNT: Address: 0x4000F024 Reset: 0x0

Bitname	Bitfield	Access	Description
TIM_CNT	[15:0]	RW	Counter value.

**Register 9.9. TIMx\_PSC****TIM1\_PSC: Timer 1 Prescaler Register****TIM2\_PSC: Timer 2 Prescaler Register**

<b>Bit</b>	<b>31</b>	<b>30</b>	<b>29</b>	<b>28</b>	<b>27</b>	<b>26</b>	<b>25</b>	<b>24</b>
<b>Name</b>	0	0	0	0	0	0	0	0
<b>Bit</b>	<b>23</b>	<b>22</b>	<b>21</b>	<b>20</b>	<b>19</b>	<b>18</b>	<b>17</b>	<b>16</b>
<b>Name</b>	0	0	0	0	0	0	0	0
<b>Bit</b>	<b>15</b>	<b>14</b>	<b>13</b>	<b>12</b>	<b>11</b>	<b>10</b>	<b>9</b>	<b>8</b>
<b>Name</b>	0	0	0	0	0	0	0	0
<b>Bit</b>	<b>7</b>	<b>6</b>	<b>5</b>	<b>4</b>	<b>3</b>	<b>2</b>	<b>1</b>	<b>0</b>
<b>Name</b>	0	0	0	0	TIM_PSC			

TIM1\_PSC: Address: 0x4000E028 Reset: 0x0

TIM2\_PSC: Address: 0x4000F028 Reset: 0x0

Bitname	Bitfield	Access	Description
TIM_PSC	[3:0]	RW	The prescaler divides the internal timer clock frequency. The counter clock frequency CK_CNT is equal to $f_{CK\_PSC} / (2^{\wedge} TIM\_PSC)$ . Clock division factors can range from 1 through 32768. The division factor is loaded into the shadow prescaler register at each UEV (including when the counter is cleared through TIM_UG bit of TMR1_EGR register or through the trigger controller when configured in reset mode).



# EM341

## Register 9.10. TIMx\_ARR

TIM1\_ARR: Timer 1 Auto-Reload Register

TIM2\_ARR: Timer 2 Auto-Reload Register

Bit	31	30	29	28	27	26	25	24
Name	0	0	0	0	0	0	0	0
Bit	23	22	21	20	19	18	17	16
Name	0	0	0	0	0	0	0	0
Bit	15	14	13	12	11	10	9	8
Name	TIM_ARR							
Bit	7	6	5	4	3	2	1	0
Name	TIM_ARR							

TIM1\_ARR: Address: 0x4000E02C Reset: 0xFFFF

TIM2\_ARR: Address: 0x4000F02C Reset: 0xFFFF

Bitname	Bitfield	Access	Description
TIM_ARR	[15:0]	RW	TIM_ARR is the value to be loaded in the shadow auto-reload register. The auto-reload register is buffered. Writing or reading the auto-reload register accesses the buffer register. The content of the buffer register is transferred in the shadow register permanently or at each UEV, depending on the auto-reload buffer enable bit (TIM_ARBE) in TMRx_CR1 register. The UEV is sent when the counter reaches the overflow point (or underflow point when down-counting) and if the TIM_UDIS bit equals 0 in the TMRx_CR1 register. It can also be generated by software. The counter is blocked while the auto-reload value is 0.

**Register 9.11. TIMx\_CCR1****TIM1\_CCR1: Timer 1 Capture/Compare Register 1****TIM2\_CCR1: Timer 2 Capture/Compare Register 1**

<b>Bit</b>	<b>31</b>	<b>30</b>	<b>29</b>	<b>28</b>	<b>27</b>	<b>26</b>	<b>25</b>	<b>24</b>
<b>Name</b>	0	0	0	0	0	0	0	0
<b>Bit</b>	<b>23</b>	<b>22</b>	<b>21</b>	<b>20</b>	<b>19</b>	<b>18</b>	<b>17</b>	<b>16</b>
<b>Name</b>	0	0	0	0	0	0	0	0
<b>Bit</b>	<b>15</b>	<b>14</b>	<b>13</b>	<b>12</b>	<b>11</b>	<b>10</b>	<b>9</b>	<b>8</b>
<b>Name</b>	TIM_CCR							
<b>Bit</b>	<b>7</b>	<b>6</b>	<b>5</b>	<b>4</b>	<b>3</b>	<b>2</b>	<b>1</b>	<b>0</b>
<b>Name</b>	TIM_CCR							

TIM1\_CCR1: Address: 0x4000E034 Reset: 0x0

TIM2\_CCR1: Address: 0x4000F034 Reset: 0x0

<b>Bitname</b>	<b>Bitfield</b>	<b>Access</b>	<b>Description</b>
TIM_CCR	[15:0]	RW	<p>If the CC1 channel is configured as an output (TIM_CC1S = 0): TIM_CCR1 is the buffer value to be loaded in the actual capture/compare 1 register. It is loaded permanently if the preload feature is not selected in the TMR1_CCMR1 register (bit OC1PE). Otherwise the buffer value is copied to the shadow capture/compare 1 register when an UEV occurs. The active capture/compare register contains the value to be compared to the counter TMR1_CNT and signaled on the OC1 output.</p> <p>If the CC1 channel is configured as an input (TIM_CC1S is not 0): CCR1 is the counter value transferred by the last input capture 1 event (IC1).</p>

# EM341

## Register 9.12. TIMx\_CCR2

TIM1\_CCR2: Timer 1 Capture/Compare Register 2

TIM2\_CCR2: Timer 2 Capture/Compare Register 2

Bit	31	30	29	28	27	26	25	24
Name	0	0	0	0	0	0	0	0
Bit	23	22	21	20	19	18	17	16
Name	0	0	0	0	0	0	0	0
Bit	15	14	13	12	11	10	9	8
Name	TIM_CCR							
Bit	7	6	5	4	3	2	1	0
Name	TIM_CCR							

TIM1\_CCR2: Address: 0x4000E038 Reset: 0x0

TIM2\_CCR2: Address: 0x4000F038 Reset: 0x0

Bitname	Bitfield	Access	Description
TIM_CCR	[15:0]	RW	See description in the TIMx_CCR1 register.

## Register 9.13. TIMx\_CCR3

TIM1\_CCR3: Timer 1 Capture/Compare Register 3

TIM2\_CCR3: Timer 2 Capture/Compare Register 3

Bit	31	30	29	28	27	26	25	24
Name	0	0	0	0	0	0	0	0
Bit	23	22	21	20	19	18	17	16
Name	0	0	0	0	0	0	0	0
Bit	15	14	13	12	11	10	9	8
Name	TIM_CCR							
Bit	7	6	5	4	3	2	1	0
Name	TIM_CCR							

TIM1\_CCR3: Address: 0x4000E03C Reset: 0x0

TIM2\_CCR3: Address: 0x4000F03C Reset: 0x0

Bitname	Bitfield	Access	Description
TIM_CCR	[15:0]	RW	See description in the TIMx_CCR1 register.

**Register 9.14. TIMx\_CCR4****TIM1\_CCR4: Timer 1 Capture/Compare Register 4****TIM2\_CCR4: Timer 2 Capture/Compare Register 4**

<b>Bit</b>	<b>31</b>	<b>30</b>	<b>29</b>	<b>28</b>	<b>27</b>	<b>26</b>	<b>25</b>	<b>24</b>
<b>Name</b>	0	0	0	0	0	0	0	0
<b>Bit</b>	<b>23</b>	<b>22</b>	<b>21</b>	<b>20</b>	<b>19</b>	<b>18</b>	<b>17</b>	<b>16</b>
<b>Name</b>	0	0	0	0	0	0	0	0
<b>Bit</b>	<b>15</b>	<b>14</b>	<b>13</b>	<b>12</b>	<b>11</b>	<b>10</b>	<b>9</b>	<b>8</b>
<b>Name</b>	TIM_CCR							
<b>Bit</b>	<b>7</b>	<b>6</b>	<b>5</b>	<b>4</b>	<b>3</b>	<b>2</b>	<b>1</b>	<b>0</b>
<b>Name</b>	TIM_CCR							

TIM1\_CCR4: Address: 0x4000E040 Reset: 0x0

TIM2\_CCR4: Address: 0x4000F040 Reset: 0x0

<b>Bitname</b>	<b>Bitfield</b>	<b>Access</b>	<b>Description</b>
TIM_CCR	[15:0]	RW	See description in the TIMx_CCR1 register.

# EM341

**Register 9.15. TIM1\_OR: Timer 1: Option Register**

<b>Bit</b>	<b>31</b>	<b>30</b>	<b>29</b>	<b>28</b>	<b>27</b>	<b>26</b>	<b>25</b>	<b>24</b>
<b>Name</b>	0	0	0	0	0	0	0	0
<b>Bit</b>	<b>23</b>	<b>22</b>	<b>21</b>	<b>20</b>	<b>19</b>	<b>18</b>	<b>17</b>	<b>16</b>
<b>Name</b>	0	0	0	0	0	0	0	0
<b>Bit</b>	<b>15</b>	<b>14</b>	<b>13</b>	<b>12</b>	<b>11</b>	<b>10</b>	<b>9</b>	<b>8</b>
<b>Name</b>	0	0	0	0	0	0	0	0
<b>Bit</b>	<b>7</b>	<b>6</b>	<b>5</b>	<b>4</b>	<b>3</b>	<b>2</b>	<b>1</b>	<b>0</b>
<b>Name</b>	0	0	0	0	TIM_ORRSVD	TIM_CLKMSKEN	TIM_EXTRIGSEL	

Timer 1: Address: 0x4000E050 Reset: 0x0

Bitname	Bitfield	Access	Description
TIM_ORRSVD	[3]	RW	Reserved: this bit must always be set to 0.
TIM_CLKMSKEN	[2]	RW	Enables TIM1MSK when TIM1CLK is selected as the external trigger: 0 = TIM1MSK not used, 1 = TIM1CLK is ANDed with the TIM1MSK input.
TIM_EXTRIGSEL	[1:0]	RW	Selects the external trigger used in external clock mode 2: 0 = PCLK, 1 = calibrated 1 kHz clock, 2 = 32 kHz reference clock (if available), 3 = TIM1CLK pin.

**Register 9.16. TIM2\_OR: Timer 2 Option Register**

<b>Bit</b>	<b>31</b>	<b>30</b>	<b>29</b>	<b>28</b>	<b>27</b>	<b>26</b>	<b>25</b>	<b>24</b>
<b>Name</b>	0	0	0	0	0	0	0	0
<b>Bit</b>	<b>23</b>	<b>22</b>	<b>21</b>	<b>20</b>	<b>19</b>	<b>18</b>	<b>17</b>	<b>16</b>
<b>Name</b>	0	0	0	0	0	0	0	0
<b>Bit</b>	<b>15</b>	<b>14</b>	<b>13</b>	<b>12</b>	<b>11</b>	<b>10</b>	<b>9</b>	<b>8</b>
<b>Name</b>	0	0	0	0	0	0	0	0
<b>Bit</b>	<b>7</b>	<b>6</b>	<b>5</b>	<b>4</b>	<b>3</b>	<b>2</b>	<b>1</b>	<b>0</b>
<b>Name</b>	TIM_REMAPC4	TIM_REMAPC3	TIM_REMAPC2	TIM_REMAPC1	TIM_ORRSVD	TIM_CLKMSKEN	TIM_EXTRIGSEL	

Address: 0x4000F050 Reset: 0x0

Bitname	Bitfield	Access	Description
TIM_REMAPC4	[7]	RW	Selects the GPIO used for TIM2C4: 0 = PA2, 1 = PB4.
TIM_REMAPC3	[6]	RW	Selects the GPIO used for TIM2C3: 0 = PA1, 1 = PB3.
TIM_REMAPC2	[5]	RW	Selects the GPIO used for TIM2C2: 0 = PA3, 1 = PB2.
TIM_REMAPC1	[4]	RW	Selects the GPIO used for TIM2C1: 0 = PA0, 1 = PB1.
TIM_ORRSVD	[3]	RW	Reserved: this bit must always be set to 0.
TIM_CLKMSKEN	[2]	RW	Enables TIM2MSK when TIM2CLK is selected as the external trigger: 0 = TIM2MSK not used, 1 = TIM2CLK is ANDed with the TIM2MSK input.
TIM_EXTRIGSEL	[1:0]	RW	Selects the external trigger used in external clock mode 2: 0 = PCLK, 1 = calibrated 1 kHz clock, 2 = 32 kHz reference clock (if available), 3 = TIM2CLK pin.

# EM341

## Register 9.17. INT\_TIMxCFG

INT\_TIM1CFG: Timer 1 Interrupt Configuration Register

INT\_TIM2CFG: Timer 2 Interrupt Configuration Register

<b>Bit</b>	<b>31</b>	<b>30</b>	<b>29</b>	<b>28</b>	<b>27</b>	<b>26</b>	<b>25</b>	<b>24</b>
<b>Name</b>	0	0	0	0	0	0	0	0
<b>Bit</b>	<b>23</b>	<b>22</b>	<b>21</b>	<b>20</b>	<b>19</b>	<b>18</b>	<b>17</b>	<b>16</b>
<b>Name</b>	0	0	0	0	0	0	0	0
<b>Bit</b>	<b>15</b>	<b>14</b>	<b>13</b>	<b>12</b>	<b>11</b>	<b>10</b>	<b>9</b>	<b>8</b>
<b>Name</b>	0	0	0	0	0	0	0	0
<b>Bit</b>	<b>7</b>	<b>6</b>	<b>5</b>	<b>4</b>	<b>3</b>	<b>2</b>	<b>1</b>	<b>0</b>
<b>Name</b>	0	INT_TIMTIF	0	INT_TIMCC4IF	INT_TIMCC3IF	INT_TIMCC2IF	INT_TIMCC1IF	INT_TIMUIF

INT\_TIM1CFG: Address: 0x4000A840 Reset: 0x0

INT\_TIM2CFG: Address: 0x4000A844 Reset: 0x0

Bitname	Bitfield	Access	Description
INT_TIMTIF	[6]	RW	Trigger interrupt enable.
INT_TIMCC4IF	[4]	RW	Capture or compare 4 interrupt enable.
INT_TIMCC3IF	[3]	RW	Capture or compare 3 interrupt enable.
INT_TIMCC2IF	[2]	RW	Capture or compare 2 interrupt enable.
INT_TIMCC1IF	[1]	RW	Capture or compare 1 interrupt enable.
INT_TIMUIF	[0]	RW	Update interrupt enable.

**Register 9.18. INT\_TIMxFLAG****INT\_TIM1FLAG: Timer 1 Interrupt Flag Register****INT\_TIM2FLAG: Timer 2 Interrupt Flag Register**

<b>Bit</b>	<b>31</b>	<b>30</b>	<b>29</b>	<b>28</b>	<b>27</b>	<b>26</b>	<b>25</b>	<b>24</b>
<b>Name</b>	0	0	0	0	0	0	0	0
<b>Bit</b>	<b>23</b>	<b>22</b>	<b>21</b>	<b>20</b>	<b>19</b>	<b>18</b>	<b>17</b>	<b>16</b>
<b>Name</b>	0	0	0	0	0	0	0	0
<b>Bit</b>	<b>15</b>	<b>14</b>	<b>13</b>	<b>12</b>	<b>11</b>	<b>10</b>	<b>9</b>	<b>8</b>
<b>Name</b>	0	0	0	INT_TIMRSVD				0
<b>Bit</b>	<b>7</b>	<b>6</b>	<b>5</b>	<b>4</b>	<b>3</b>	<b>2</b>	<b>1</b>	<b>0</b>
<b>Name</b>	0	INT_TIMTIF	0	INT_TIMCC4IF	INT_TIMCC3IF	INT_TIMCC2IF	INT_TIMCC1IF	INT_TIMUIF

INT\_TIM1FLAG: Address: 0x4000A800 Reset: 0x0

INT\_TIM2FLAG: Address: 0x4000A804 Reset: 0x0

<b>Bitname</b>	<b>Bitfield</b>	<b>Access</b>	<b>Description</b>
INT_TIMRSVD	[12:9]	R	May change during normal operation.
INT_TIMTIF	[6]	RW	Trigger interrupt.
INT_TIMCC4IF	[4]	RW	Capture or compare 4 interrupt pending.
INT_TIMCC3IF	[3]	RW	Capture or compare 3 interrupt pending.
INT_TIMCC2IF	[2]	RW	Capture or compare 2 interrupt pending.
INT_TIMCC1IF	[1]	RW	Capture or compare 1 interrupt pending.
INT_TIMUIF	[0]	RW	Update interrupt pending.



# EM341

## Register 9.19. INT\_TIMxMISS

INT\_TIM1MISS: Timer 1 Missed Interrupt Register

INT\_TIM2MISS: Timer 2 Missed Interrupts Register

Bit	31	30	29	28	27	26	25	24
Name	0	0	0	0	0	0	0	0
Bit	23	22	21	20	19	18	17	16
Name	0	0	0	0	0	0	0	0
Bit	15	14	13	12	11	10	9	8
Name	0	0	0	INT_ TIMMISSCC4IF	INT_ TIMMISSCC3IF	INT_ TIMMISSCC2IF	INT_ TIMMISSCC1IF	0
Bit	7	6	5	4	3	2	1	0
Name	0	INT_TIMMISSRSVD						

INT\_TIM1MISS: Address: 0x4000A818 Reset: 0x0

INT\_TIM2MISS: Address: 0x4000A81C Reset: 0x0

Bitname	Bitfield	Access	Description
INT_TIMMISSCC4IF	[12]	RW	Capture or compare 4 interrupt missed.
INT_TIMMISSCC3IF	[11]	RW	Capture or compare 3 interrupt missed.
INT_TIMMISSCC2IF	[10]	RW	Capture or compare 2 interrupt missed.
INT_TIMMISSCC1IF	[9]	RW	Capture or compare 1 interrupt missed.
INT_TIMMISSRSVD	[6:0]	R	May change during normal operation.

## 10. ADC (Analog to Digital Converter)

The EM341 ADC is a first-order sigma-delta converter with the following features:

- Resolution of up to 14 bits
- Sample times as fast as 5.33  $\mu$ s (188 kHz)
- Differential and single-ended conversions from six external and four internal sources
- One voltage range (differential): -VREF to +VREF
- Internal VREF may be output to PB0
- Digital offset and gain correction
- Dedicated DMA channel with one-shot and continuous operating modes

Figure 10.1 shows the basic ADC structure.

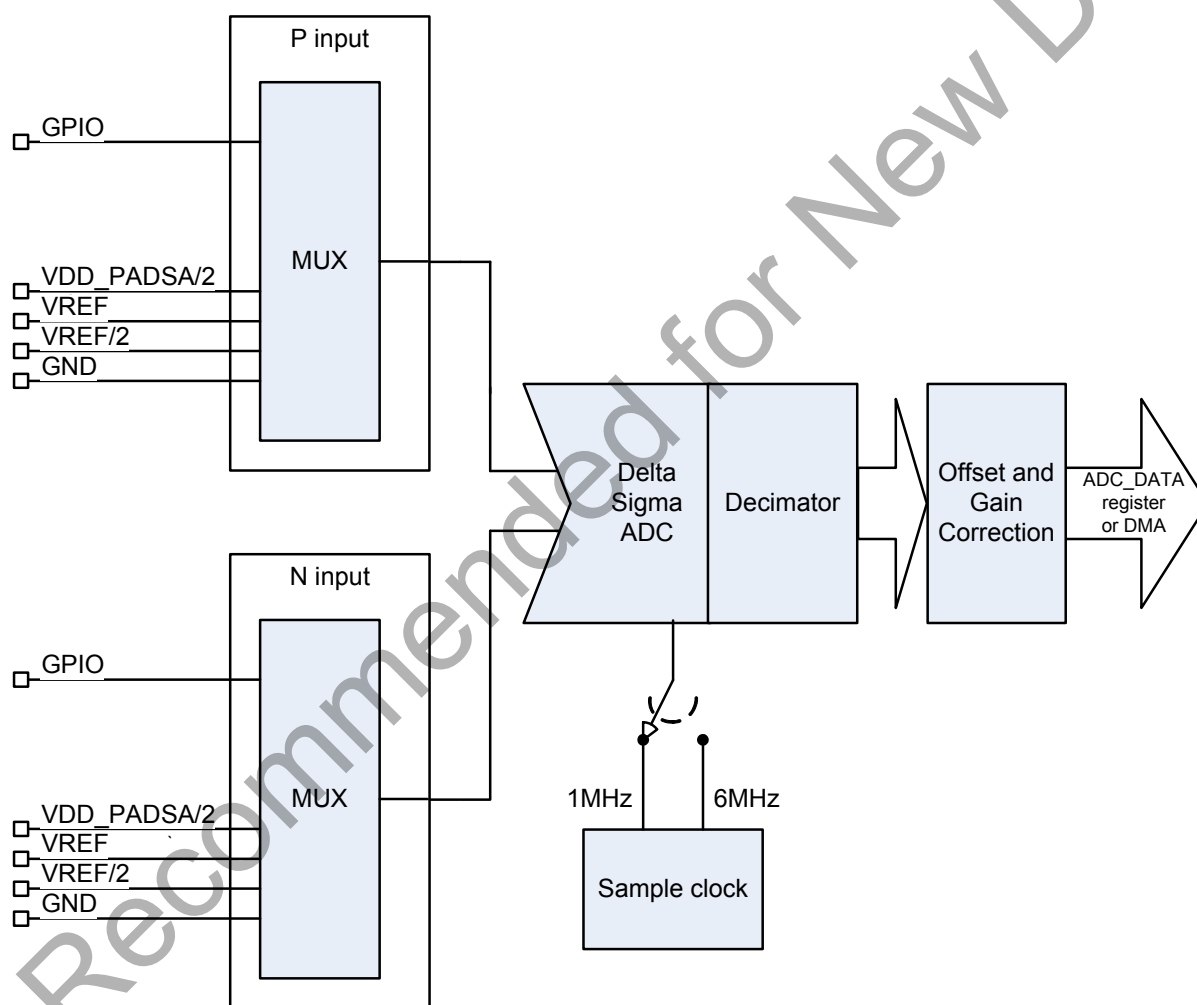

Figure 10.1. ADC Block Diagram

While the ADC Module supports both single-ended and differential inputs, the ADC input stage always operates in differential mode. Single-ended conversions are performed by connecting one of the differential inputs to VREF/2 while fully differential operation uses two external inputs.

**Note:** The regulator input voltage, VDD\_PADS, cannot be measured using the ADC, but it can be measured through Ember software.

## 10.1. Setup and Configuration

To use the ADC follow this procedure, described in more detail in the next sections:

- Configure any GPIO pins to be used by the ADC in analog mode.
- Set the offset and gain values.
- If using DMA, reset the ADC DMA, define the DMA buffer, and start the DMA in the proper transfer mode.
- If interrupts will be used, configure the top-level and second-level ADC interrupt bits.
- Write the ADC configuration register to define the inputs, sample time, and start the conversions.

### 10.1.1. GPIO Usage

A GPIO pin used by the ADC as an input or voltage reference must be configured in analog mode by writing 0 to its 4-bit field in the proper GPIO\_PxCFGL/L register. Note that a GPIO pin in analog mode cannot be used for any digital functions, and GPIO\_PxIN always reads it as 1. Only certain pins can be configured in analog mode. These are listed in Table 10.1.

**Table 10.1. ADC GPIO Pin Usage**

Analog Signal	GPIO	Configuration control
ADC0 input	PB5	GPIO_PBCFGH[7:4]
ADC1 input	PB6	GPIO_PBCFGH[11:8]
ADC2 input	PB7	GPIO_PBCFGH[15:12]
ADC3 input	PC1	GPIO_PCCFGL[7:4]
ADC4 input	PA4	GPIO_PACFGH[3:0]
ADC5 input	PA5	GPIO_PACFGH[7:4]
VREF output	PB0	GPIO_PBCFGL[3:0]

See "7. GPIO (General Purpose Input/Output)" on page 48 for more information about how to configure GPIO.

### 10.1.2. Voltage Reference

The ADC voltage reference (VREF) may optionally be output on PB0. To output the internal VREF on PB0, the ADC must be enabled (ADC\_ENABLE bit set in the ADC\_CFG register) and PB0 must be configured in analog mode.

### 10.1.3. Offset/Gain Correction

When a conversion is complete, the 16-bit converted data is processed in several steps by offset/gain correction hardware:

1. The initial signed ADC conversion result is added to the 16-bit signed (two's complement) value of the ADC offset register (ADC\_OFFSET).
2. The offset-corrected data is multiplied by the 16-bit ADC gain register, ADC\_GAIN, to produce a 16-bit signed result. If the product is greater than 0x7FFF (32767), or less than 0x8000 (–32768), it is limited to that value and the INT\_ADCSAT bit is set in the INT\_ADCFLAG register.
3. The offset/gain corrected value is divided by two to produce the final result.

ADC\_GAIN is an unsigned scaled 16-bit value: ADC\_GAIN[15] is the integer part of the gain factor and ADC\_GAIN[14:0] is the fractional part. As a result, ADC\_GAIN values can represent gain factors from 0 through (2 - 2<sup>-15</sup>). Although ADC\_GAIN can represent a much greater range, its purpose is to correct small gain error, and in practice is loaded with values within a range of about 0.95 to 1.05.

Reset initializes the offset to zero (ADC\_OFFSET = 0) and gain factor to one (ADC\_GAIN = 0x8000).

### 10.1.4. DMA

The ADC DMA channel writes converted data, which incorporates the offset/gain correction, into a DMA buffer in RAM.

The ADC DMA buffer is defined by two registers:

- ADC\_DMABEG is the start address of the buffer and must be even.
- ADC\_DMASIZE specifies the size of the buffer in 16-bit samples, or half its length in bytes.

To prepare the DMA channel for operation, reset it by writing the ADC\_DMARST bit in the ADC\_DMACFG register, then start the DMA in either linear or auto wrap mode by setting the ADC\_DMALOAD bit in the ADC\_DMACFG register. The ADC\_DMAAUTOWRAP bit in the ADC\_DMACFG register selects the DMA mode: 0 for linear mode, 1 for auto wrap mode.

- In linear mode the DMA writes to the buffer until the number of samples given by ADC\_DMASIZE has been output. The DMA then stops and sets the INT\_ADCULDFULL bit in the INT\_ADCFLAG register. If another ADC conversion completes before the DMA is reset or the ADC is disabled, the INT\_ADCOVF bit in the INT\_ADCFLAG register is set.
- In auto wrap mode the DMA writes to the buffer until it reaches the end, then resets its pointer to the start of the buffer and continues writing samples. The DMA transfers continue until the ADC is disabled or the DMA is reset.

When the DMA fills the lower and upper halves of the buffer, it sets the INT\_ADCULDHAF and INT\_ADCULDFULL bits, respectively, in the INT\_ADCFLAG register. The current location to which the DMA is writing can also be determined by reading the ADC\_DMACUR register.

### 10.1.5. ADC Configuration Register

The ADC configuration register (ADC\_CFG) sets up most of the ADC operating parameters.

#### 10.1.5.1. Input

The analog input of the ADC can be chosen from various sources. The analog input is configured with the ADC\_MUXP and ADC\_MUXN bits within the ADC\_CFG register. Table 10.2 shows the possible input selections.

Table 10.2. ADC Inputs

ADC_MUXn*	Analog Source at ADC	GPIO Pin	Purpose
0	ADC0	PB5	
1	ADC1	PB6	
2	ADC2	PB7	
3	ADC3	PC1	
4	ADC4	PA4	
5	ADC5	PA5	
6	No connection		
7	No connection		
8	GND	Internal connection	Calibration
9	VREF/2	Internal connection	Calibration
10	VREF	Internal connection	Calibration
11	VDD_PADSA/2	Internal connection	Supply monitoring and calibration
12	No connection		
13	No connection		
14	No connection		
15	No connection		

\*Note: Denotes bits ADC\_MUXP or ADC\_MUXN in register ADC\_CFG.

Table 10.3 shows the typical configurations of ADC inputs.

Table 10.3. Typical ADC Input Configurations

ADC P Input	ADC N Input	ADC_MUXP	ADC_MUXN	Purpose
ADC0	VREF/2	0	9	Single-ended
ADC1	VREF/2	1	9	Single-ended
ADC2	VREF/2	2	9	Single-ended
ADC3	VREF/2	3	9	Single-ended
ADC4	VREF/2	4	9	Single-ended
ADC5	VREF/2	5	9	Single-ended
ADC1	ADC0	1	0	Differential
ADC3	ADC2	3	2	Differential
ADC5	ADC4	5	4	Differential
GND	VREF/2	8	9	Calibration
VREF	VREF/2	10	9	Calibration
VDD_PADSA/2	VREF/2	11	9	Calibration

### 10.1.5.2. Input Range

The single-ended input range is fixed as 0 V to VREF and the differential input range is fixed as –VREF to +VREF.

### 10.1.5.3. Sample Time

ADC sample time is programmed by selecting the sampling clock and the clocks per sample.

- The sampling clock may be either 1 MHz or 6 MHz. If the ADC\_1MHZCLK bit in the ADC\_CFG register is clear, the 6 MHz clock is used; if it is set, the 1 MHz clock is selected. The 6 MHz sample clock offers faster conversion times but the ADC resolution is lower than that achieved with the 1 MHz clock.
- The number of clocks per sample is determined by the ADC\_PERIOD bits in the ADC\_CFG register. ADC\_PERIOD values select from 32 to 4096 sampling clocks in powers of two. Longer sample times produce more significant bits. Regardless of the sample time, converted samples are always 16-bits in size with the significant bits left-aligned within the value.

Table 10.4 shows the options for ADC sample times and the significant bits in the conversion results.

**Table 10.4. ADC Sample Times\***

ADC_PERIOD	Sample Clocks	Sample Time (µs)		Sample Frequency (kHz)		Significant Bits
		1 MHz Clock	6 MHz Clock	1 MHz Clock	6 MHz Clock	
0	32	32	5.33	31.3	188	7
1	64	64	10.7	15.6	93.8	8
2	128	128	21.3	7.81	46.9	9
3	256	256	42.7	3.91	23.4	10
4	512	512	85.3	1.95	11.7	11
5	1024	1024	170	0.977	5.86	12
6	2048	2048	341	0.488	2.93	13
7	4096	4096	682	0.244	1.47	14

\*Note: ADC sample timing is the same whether the EM341 is using the 24 MHz crystal oscillator or the 12 MHz high-speed RC oscillator. This facilitates using the ADC soon after the CPU wakes from deep sleep, before switching to the crystal oscillator.

## 10.2. Interrupts

The ADC has its own top-level interrupt in the NVIC. The ADC interrupt is enabled by writing the INT\_ADC bit to the INT\_CFGSET register, and cleared by writing the INT\_ADC bit to the INT\_CFGCLR register. "9. Interrupt System" on page 100, describes the interrupt system in detail.

Five kinds of ADC events can generate an ADC interrupt, and each has a bit flag in the INT\_ADCFLAG register to identify the reason(s) for the interrupt:

- INT\_ADCOVF – an ADC conversion result was ready but the DMA was disabled (DMA buffer overflow).
- INT\_ADCSAT – the gain correction multiplication exceeded the limits for a signed 16-bit number (gain saturation).
- INT\_ADCULDFULL – the DMA wrote to the last location in the buffer (DMA buffer full).
- INT\_ADCULDHALF – the DMA wrote to the last location of the first half of the DMA buffer (DMA buffer half full).
- INT\_ADCDATA – there is data ready in the ADC\_DATA register.

Bits in INT\_ADCFLAG register may be cleared by writing a 1 to their position. Writing 0 to any bit in the INT\_ADCFLAG register is ineffectual.

The INT\_ADCCFG register controls whether or not INT\_ADCFLAG register bits actually propagate the ADC interrupt to the NVIC. Only the events whose bits are 1 in the INT\_ADCCFG register can do so.

For non-interrupt (polled) ADC operation set the INT\_ADCCFG register to zero, and read the bit flags in the INT\_ADCFLAG register to determine the ADC status.

**Note:** When making changes to the ADC configuration it is best to disable the DMA beforehand. If this isn't done it can be difficult to determine at which point the sampled data in the DMA buffer switched from the old configuration to the new configuration. However, since the ADC will be left running, if it completes a conversion after the DMA is disabled, the INT\_ADCOVF flag will be set. To prevent these unwanted DMA buffer overflow indications, clear the INT\_ADCOVF flag immediately after enabling the DMA, preferably with interrupts off. Disabling the ADC in addition to the DMA is often undesirable because of the additional analog startup time when it is re-enabled.

## 10.3. Operation

Setting the ADC\_EN bit in the ADC\_CFG register enables the ADC. Once the ADC is enabled, it performs conversions continuously until it is disabled. If the ADC had previously been disabled, a 21  $\mu$ s analog startup delay is automatically imposed before the ADC starts conversions. The delay timing is performed in hardware and is simply added to the time until the first conversion result is output.

When the ADC is first enabled, and/or if any change is made to ADC\_CFG after it is enabled, the time until a result is output is double the normal sample time. This is because the ADC's internal design requires it to discard the first conversion after startup or a configuration change. This is done automatically and is hidden from software. Switching the system clock between OSCHF and OSC24M also causes the ADC to go through this startup cycle. If the ADC was newly enabled, the analog delay time is added to the doubled sample time.

If the DMA is running when the ADC\_CFG register is modified, the DMA does not stop, so the DMA buffer may contain conversion results from both the old and new configurations.

The following procedure illustrates a simple polled method of using the ADC without DMA. This assumes that any GPIOs and the voltage reference have already been configured.

1. Disable all ADC interrupts: Write 0 to the INT\_ADCCFG register.
2. Write the desired offset and gain correction values to the ADC\_OFFSET and ADC\_GAIN registers.
3. Write the desired conversion configuration, with the ADC\_EN bit set, to ADC\_CFG register.
4. Clear the ADC data flag: Write the INT\_ADCDATA bit to INT\_ADCFLAG register.
5. Wait until the INT\_ADCDATA bit is set in INT\_ADCFLAG register, then read the result, as a 16-bit signed variable, from the ADC\_DATA register.

The following procedure illustrates a simple polled method of using the ADC with DMA. After completing the procedure, the latest conversion results are available in the location written to by the DMA. This assumes that any GPIOs and the voltage reference have already been configured.

1. Allocate a 16-bit signed variable, for example analogData, to receive the ADC output. (Make sure that analogData is half-word aligned – that is, at an even address.)
2. Disable all ADC interrupts: Write 0 to the INT\_ADCCFG register.
3. Set up the DMA to output conversion results to the variable, analogData.  
Reset the DMA: Set the ADC\_DMARST bit in ADC\_DMACFG register.  
Define a one sample buffer: Write analogData's address to the ADC\_DMABEG register and set the ADC\_DMASIZE register to 1.
4. Write the desired offset and gain correction values to the ADC\_OFFSET and ADC\_GAIN registers.
5. Start the ADC and the DMA.  
Write the desired conversion configuration, with the ADC\_EN bit set, to the ADC\_CFG register.  
Clear the ADC buffer full flag: Write the INT\_ADCULDFULL bit to the INT\_ADCFLAG register.  
Start the DMA in auto wrap mode: Set the ADC\_DMAAUTOWRAP and ADC\_DMALOAD bits in the ADC\_DMACFG register.

- Wait until the INT\_ADCULDFULL bit is set in the INT\_ADCFLAG register, then read the result from analogData.

To convert multiple inputs using this approach, repeat steps 4 through 6, loading the desired input configurations to the ADC\_CFG register in Step 5. If the inputs can use the same offset/gain correction, just repeat steps 5 and 6.

#### 10.4. Calibration

Sampling of internal connections GND, VREF/2, and VREF allow for offset and gain calibration of the ADC in applications where absolute accuracy is important. Offset error is calculated from the minimum input, and gain error is calculated from the full-scale input range. Correction using VREF is recommended because VREF is calibrated by the Ember software against VDD\_PADSA. The VDD\_PADSA regulator is factory-trimmed to 1.80 V  $\pm$ 20 mV. The ADC calibrates as a single-ended measurement. Differential signals require correction of both their inputs.

The following steps outline the calibration procedure:

- Calibrate VREF against VDD\_PADSA.
- Determine the ADC gain by sampling independently VREF and GND. Gain is calculated from the slope of these two measurements.
- Apply gain correction.
- Determine the ADC offset by sampling GND.
- Apply offset correction.

Table 10.5 shows the equations used to calculate the gain and offset correction values.

**Table 10.5. ADC Gain and Offset Correction Equations**

Calibration	Correction Value
Gain	$32768 \times \frac{16384}{(N_{VREF} - N_{GND})}$
Offset (after applying gain correction)	$2 \times (57344 - N_{GND})$
<b>Notes:</b> <ol style="list-style-type: none"> <li>The ADC output is 2s complement. All N are therefore 16-bit 2s complement numbers.</li> <li>Offset is a 16-bit 2s complement number.</li> <li>Gain is a 16-bit number representing a gain of 0 to 65535/32768 in 1/32768 steps. The default value is 32768, corresponding to a gain of 1.</li> <li>NGND is a sampling of ground. Due to the ADC's internal design, VGND does not yield the minimum 16 bit 2s complement value 32768 as the conversion result. Instead, VGND yields a value close to 57344 when the input buffer is not selected. VGND cannot be measured when the input buffer is enabled because it is outside the buffer's input range.</li> <li>NVREF is a sampling of VREF. Due to the ADC's internal design, VREF does not yield the maximum positive 16-bit 2s complement 32767 as the conversion result. Instead, VREF yields a value close to 8192.</li> <li>NVREF/2 is a sampling of VREF/2. VREF/2 yields a value close to 0.</li> <li>Offset correction is affected by the gain correction value. Offset correction is calculated after gain correction has been applied.</li> </ol>	



## 10.5. ADC Key Parameters

Table 10.6 describes the key ADC parameters measured on Silicon Labs' EM357 reference design at 25 °C and VDD\_PADS at 3.0 V, for a sampling clock of 1 MHz. The single-ended measurements were done at  $f_{\text{input}} = 7.7\% f_{\text{Nyquist}}$ ; 0 dBFS level (where full-scale is a 1.2 V p-p swing). The differential measurements were done at  $f_{\text{input}} = 7.7\% f_{\text{Nyquist}}$ ; -6 dBFS level (where full-scale is a 2.4 V p-p swing) and a common mode voltage of 0.6 V.

**Table 10.6. ADC Module Key Parameters for 1 MHz Sampling**

Parameter	Performance							
	0	1	2	3	4	5	6	7
ADC_PERIOD	0	1	2	3	4	5	6	7
Conversion Time (µs)	32	64	128	256	512	1024	2048	4096
Nyquist Freq (kHz)	15.6k	7.81k	3.91k	1.95k	977	488	244	122
3 dB Cut-off (kHz)	9.43k	4.71k	2.36k	1.18k	589	295	147	73.7
INL (codes peak) <sup>1</sup>	0.083	0.092	0.163	0.306	0.624	1.229	2.451	4.926
INL (codes RMS) <sup>1</sup>	0.047	0.051	0.093	0.176	0.362	0.719	1.435	2.848
DNL (codes peak) <sup>1</sup>	0.028	0.035	0.038	0.044	0.074	0.113	0.184	0.333
DNL (codes RMS) <sup>1</sup>	0.008	0.009	0.011	0.014	0.019	0.029	0.048	0.079
ENOB (from single-cycle test)	5.6	7.0	8.6	10.1	11.5	12.6	13.0	13.2
SNR (dB) <sup>2</sup>								
Single-Ended	35	44	53	62	70	75	77	77
Differential	35	44	53	62	71	77	79	80
SINAD (dB) <sup>2</sup>								
Single-Ended	35	44	53	61	67	69	70	70
Differential	35	44	53	62	70	75	76	76
SDFR (dB)								
Single-Ended	59	68	72	72	72	72	72	73
Differential	60	69	77	80	81	81	81	81
THD (dB)								
Single-Ended	-45	-54	-62	-67	-69	-69	-69	-69
Differential	-45	-54	-63	-71	-75	-76	-76	-76
ENOB (from SNR) <sup>2</sup>								
Single-Ended	5.6	7.1	8.6	10.0	11.3	12.2	12.4	12.5
Differential	5.6	7.1	8.6	10.1	11.4	12.5	12.9	12.9
ENOB (from SINAD) <sup>2</sup>								
Single-Ended	5.5	7.0	8.5	9.9	10.9	11.2	11.3	11.3
Differential	5.6	7.0	8.5	10.0	11.3	12.1	12.3	12.4
Equivalent ADC Bits <sup>1</sup>	7	8	9	10	11	12	13	14
	[15:9]	[15:8]	[15:7]	[15:6]	[15:5]	[15:4]	[15:3]	[15:2]

**Notes:**

1. INL and DNL are referenced to a LSB of the Equivalent ADC Bits shown in the last row of this table.
2. ENOB (effective number of bits) can be calculated from either SNR (signal to non-harmonic noise ratio) or SINAD (signal-to-noise and distortion ratio).

Table 10.7 describes the key ADC parameters measured on Silicon Labs' EM341 reference design at 25 °C and VDD\_PADS at 3.0 V, for a sampling rate of 6 MHz. The single-ended measurements were done at  $f_{\text{input}} = 7.7\% f_{\text{Nyquist}}$ , 0 dBFS level (where full-scale is a 1.2 V p-p swing). The differential measurements were done at  $f_{\text{input}} = 7.7\% f_{\text{Nyquist}}$ , -6 dBFS level (where full-scale is a 2.4 V p-p swing) and a common mode voltage of 0.6 V.

**Table 10.7. ADC Module Key Parameters for 6 MHz Sampling**

Parameter	Performance							
	0	1	2	3	4	5	6	7
ADC_PERIOD								
Conversion Time (μs)	5.33	10.7	21.3	42.7	85.3	171	341	683
Nyquist Freq (kHz)	93.8k	46.9k	23.4k	11.7k	5.86k	2.93k	1.47k	732
3 dB Cut-off (kHz)	56.6k	28.3k	14.1k	7.07k	3.54k	1.77k	884	442
INL (codes peak) <sup>1</sup>	0.084	0.084	0.15	0.274	0.518	1.057	2.106	4.174
INL (codes RMS) <sup>1</sup>	0.046	0.044	0.076	0.147	0.292	0.58	1.14	2.352
DNL (codes peak) <sup>1</sup>	0.026	0.023	0.044	0.052	0.096	0.119	0.196	0.371
DNL (codes RMS) <sup>1</sup>	0.007	0.009	0.013	0.015	0.024	0.03	0.05	0.082
ENOB (from single-cycle test)	5.6	7.0	8.5	10.0	11.4	12.6	13.1	13.2
SNR (dB) <sup>2</sup>								
Single-Ended	35	44	53	62	70	75	76	77
Differential	35	44	53	62	71	77	79	80
SINAD (dB) <sup>2</sup>								
Single-Ended	35	44	53	62	68	71	71	71
Differential	35	44	53	62	70	75	77	77
SDFR (dB)								
Single-Ended	60	68	75	75	75	75	75	75
Differential	60	69	77	80	80	80	80	80
THD (dB)								
Single-Ended	-45	-54	-63	-68	-70	-70	-70	-70
Differential	-45	-54	-63	-71	-76	-77	-78	-78
ENOB (from SNR) <sup>2</sup>								
Single-Ended	5.6	7.1	8.6	10.0	11.4	12.1	12.4	12.5
Differential	5.6	7.1	8.6	10.1	11.5	12.5	12.9	13.0
ENOB (from SINAD) <sup>2</sup>								
Single-Ended	5.5	7.0	8.5	9.9	11.0	11.4	11.5	11.5
Differential	5.6	7.1	8.6	10.1	11.4	12.4	12.8	13.0
Equivalent ADC Bits <sup>1</sup>	7 [15:9]	8 [15:8]	9 [15:7]	10 [15:6]	11 [15:5]	12 [15:4]	13 [15:3]	14 [15:2]
<b>Notes:</b>								
1. INL and DNL are referenced to a LSB of the Equivalent ADC Bits shown in the last row of this table.								
2. ENOB (effective number of bits) can be calculated from either SNR (signal to non-harmonic noise ratio) or SINAD (signal-to-noise and distortion ratio).								

# EM341

Table 10.8 describes the key ADC parameters measured on Silicon Labs' EM341 reference design at 25 °C and VDD\_PADS at 3.0 V, for a sampling clock of 6 MHz. The single-ended measurements were done at  $f_{\text{input}} = 7.7\% f_{\text{Nyquist}}$ , level = 1.2 V p-p swing centered on 1.5 V. The differential measurements were done at  $f_{\text{input}} = 7.7\% f_{\text{Nyquist}}$ , level = 1.2 V p-p swing and a common mode voltage of 1.5 V.

**Table 10.8. ADC Module Key Parameters for Input Buffer Enabled and 6 MHz Sampling**

Parameter	Performance							
	0	1	2	3	4	5	6	7
ADC_PERIOD	0	1	2	3	4	5	6	7
Conversion Time (μs)	32	64	128	256	512	1024	2048	4096
Nyquist Freq (kHz)	93.8k	46.9k	23.4k	11.7k	5.86k	2.93k	1.47k	732
3 dB Cut-off (kHz)	56.6k	28.3k	14.1k	7.07k	3.54k	1.77k	884	442
INL (codes peak) <sup>1</sup>	0.055	0.032	0.038	0.07	0.123	0.261	0.522	1.028
INL (codes RMS) <sup>1</sup>	0.028	0.017	0.02	0.04	0.077	0.167	0.326	0.65
DNL (codes peak) <sup>1</sup>	0.028	0.017	0.02	0.04	0.077	0.167	0.326	0.65
DNL (codes RMS) <sup>1</sup>	0.01	0.006	0.006	0.007	0.008	0.013	0.023	0.038
ENOB (from single-cycle test)	3.6	5.0	6.6	8.1	9.5	10.7	11.3	11.6
SNR (dB)								
Single-Ended	23	32	41	50	59	65	67	68
Differential <sup>2</sup>	23	32	41	50	59	66	69	71
SINAD (dB)								
Single-Ended	23	32	41	50	58	64	66	66
Differential <sup>2</sup>	23	32	41	50	59	66	69	71
SDFR (dB)								
Single-Ended	48	56	65	72	72	72	73	73
Differential	48	57	65	74	82	88	88	88
THD (dB)								
Single-Ended	-33	-42	-51	-59	-66	-68	-68	-68
Differential	-33	-42	-51	-60	-69	-76	-80	-82
ENOB (from SNR) <sup>2</sup>								
Single-Ended	3.6	5.1	6.6	8.1	9.5	10.5	10.9	11
Differential	3.6	5.1	6.6	8.1	9.5	10.7	11.3	11.5
ENOB (from SINAD) <sup>2</sup>								
Single-Ended	3.6	5.0	6.5	8.0	9.4	10.3	10.7	10.7
Differential	3.6	5.1	6.6	8.0	9.5	10.6	11.3	11.4
Equivalent ADC Bits <sup>1</sup>	7	8	9	10	11	12	13	14
	[15:9]	[15:8]	[15:7]	[15:6]	[15:5]	[15:4]	[15:3]	[15:2]
<b>Notes:</b>								
1. INL and DNL are referenced to a LSB of the Equivalent ADC Bits shown in the last row of this table.								
2. ENOB (effective number of bits) can be calculated from either SNR (signal to non-harmonic noise ratio) or SINAD (signal-to-noise and distortion ratio).								

Table 10.9 lists other specifications for the ADC not covered in Tables 10.6, 10.7, and 10.8.

**Table 10.9. ADC Specifications\***

Parameter	Min	Typ	Max	Units
VREF	1.17	1.2	1.23	V
VREF output current			1	mA
VREF load capacitance			10	nF
Minimum input voltage	0			V
Maximum input voltage			VREF	V
Single-ended signal range	0		VREF	V
Differential signal range	-VREF		+VREF	V
Common mode range	0		VREF	V
Input referred ADC offset	-10		10	mV
Input Impedance				M $\Omega$
1 MHz sample clock	1			
6 MHz sample clock	0.5			
Not sampling	10			
<p><b>*Note:</b> The signal-ended ADC measurements are limited in their range and only guaranteed for accuracy within the limits shown in this table. The ADC's internal design allows for measurements outside of this range (<math>\pm 200</math> mV), but the accuracy of such measurements is not guaranteed. The maximum input voltage is of more interest to the differential sampling where a differential measurement might be small, but a common mode can push the actual input voltage on one of the signals towards the upper voltage limit.</p>				

# EM341

## 10.6. Registers

### Register 10.1. ADC\_DATA: ADC Data Register

<b>Bit</b>	<b>31</b>	<b>30</b>	<b>29</b>	<b>28</b>	<b>27</b>	<b>26</b>	<b>25</b>	<b>24</b>
<b>Name</b>	0	0	0	0	0	0	0	0
<b>Bit</b>	<b>23</b>	<b>22</b>	<b>21</b>	<b>20</b>	<b>19</b>	<b>18</b>	<b>17</b>	<b>16</b>
<b>Name</b>	0	0	0	0	0	0	0	0
<b>Bit</b>	<b>15</b>	<b>14</b>	<b>13</b>	<b>12</b>	<b>11</b>	<b>10</b>	<b>9</b>	<b>8</b>
<b>Name</b>	ADC_DATA_FIELD							
<b>Bit</b>	<b>7</b>	<b>6</b>	<b>5</b>	<b>4</b>	<b>3</b>	<b>2</b>	<b>1</b>	<b>0</b>
<b>Name</b>	ADC_DATA_FIELD							

Address: 0x4000D000 Reset: 0x00000000

<b>Bitname</b>	<b>Bitfield</b>	<b>Access</b>	<b>Description</b>
ADC_DATA_FIELD	[15:0]	R	ADC conversion result. The result is a signed 2s complement value. The significant bits of the value begin at bit 15 regardless of the sample period used.

**Register 10.2. ADC\_CFG: ADC Configuration Register**

<b>Bit</b>	<b>31</b>	<b>30</b>	<b>29</b>	<b>28</b>	<b>27</b>	<b>26</b>	<b>25</b>	<b>24</b>
<b>Name</b>	0	0	0	0	0	0	0	0
<b>Bit</b>	<b>23</b>	<b>22</b>	<b>21</b>	<b>20</b>	<b>19</b>	<b>18</b>	<b>17</b>	<b>16</b>
<b>Name</b>	0	0	0	0	0	0	0	0
<b>Bit</b>	<b>15</b>	<b>14</b>	<b>13</b>	<b>12</b>	<b>11</b>	<b>10</b>	<b>9</b>	<b>8</b>
<b>Name</b>	ADC_PERIOD			ADC_CFGRSVD2		ADC_MUXP		
<b>Bit</b>	<b>7</b>	<b>6</b>	<b>5</b>	<b>4</b>	<b>3</b>	<b>2</b>	<b>1</b>	<b>0</b>
<b>Name</b>	ADC_MUXP	ADC_MUXN			ADC_1MHZCLK	ADC_CFGRSVD	ADC_ENABLE	

Address: 0x4000D004 Reset: 0x00001800

Bitname	Bitfield	Access	Description
ADC_PERIOD	[15:13]	RW	ADC sample time in clocks and the equivalent significant bits in the conversion. 0: 32 clocks (7 bits). 1: 64 clocks (8 bits). 2: 128 clocks (9 bits). 3: 256 clocks (10 bits). 4: 512 clocks (11 bits). 5: 1024 clocks (12 bits). 6: 2048 clocks (13 bits). 7: 4096 clocks (14 bits).
ADC_CFGRSVD2	[12:11]	RW	Reserved: these bits must be set to 0.
ADC_MUXP	[10:7]	RW	Input selection for the P channel. 0x0: PB5 pin. 0x1: PB6 pin. 0x2: PB7 pin. 0x3: PC1 pin. 0x4: PA4 pin. 0x5: PA5 pin. 0x8: GND (0V) (not for high voltage range). 0x9: VREF/2 (0.6 V). 0xA: VREF (1.2 V). 0xB: VDD_PADSA/2 (0.9 V) (not for high voltage range). 0x6, 0x7, 0xC-0xF: Reserved.
ADC_MUXN	[6:3]	RW	Input selection for the N channel. Refer to ADC_MUXP above for choices.
ADC_1MHZCLK	[2]	RW	Select ADC clock: 0 = 6 MHz, 1 = 1 MHz.
ADC_CFGRSVD	[1]	RW	Reserved: this bit must always be set to 0.
ADC_ENABLE	[0]	RW	Enable the ADC: write 1 to enable continuous conversions, write 0 to stop. When the ADC is started the first conversion takes twice the usual number of clocks plus 21 microseconds. If anything in this register is modified while the ADC is running, the next conversion takes twice the usual number of clocks.

## Register 10.3. ADC\_OFFSET: ADC Offset Register

Bit	31	30	29	28	27	26	25	24
Name	0	0	0	0	0	0	0	0
Bit	23	22	21	20	19	18	17	16
Name	0	0	0	0	0	0	0	0
Bit	15	14	13	12	11	10	9	8
Name	ADC_OFFSET_FIELD							
Bit	7	6	5	4	3	2	1	0
Name	ADC_OFFSET_FIELD							

Address: 0x4000D008 Reset: 0x0000

Bitname	Bitfield	Access	Description
ADC_OFFSET_FIELD	[15:0]	RW	16-bit signed offset added to the basic ADC conversion result before gain correction is applied.

## Register 10.4. ADC\_GAIN: ADC Gain Register

Bit	31	30	29	28	27	26	25	24
Name	0	0	0	0	0	0	0	0
Bit	23	22	21	20	19	18	17	16
Name	0	0	0	0	0	0	0	0
Bit	15	14	13	12	11	10	9	8
Name	ADC_GAIN_FIELD							
Bit	7	6	5	4	3	2	1	0
Name	ADC_GAIN_FIELD							

Address: 0x4000D00C Reset: 0x8000

Bitname	Bitfield	Access	Description
ADC_GAIN_FIELD	[15:0]	RW	Gain factor that is multiplied by the offset-corrected ADC result to produce the output value. The gain is a 16-bit unsigned scaled integer value with a binary decimal point between bits 15 and 14. It can represent values from 0 to (almost) 2. The reset value is a gain factor of 1.

**Register 10.5. ADC\_DMACFG: ADC DMA Configuration Register**

<b>Bit</b>	<b>31</b>	<b>30</b>	<b>29</b>	<b>28</b>	<b>27</b>	<b>26</b>	<b>25</b>	<b>24</b>
<b>Name</b>	0	0	0	0	0	0	0	0
<b>Bit</b>	<b>23</b>	<b>22</b>	<b>21</b>	<b>20</b>	<b>19</b>	<b>18</b>	<b>17</b>	<b>16</b>
<b>Name</b>	0	0	0	0	0	0	0	0
<b>Bit</b>	<b>15</b>	<b>14</b>	<b>13</b>	<b>12</b>	<b>11</b>	<b>10</b>	<b>9</b>	<b>8</b>
<b>Name</b>	0	0	0	0	0	0	0	0
<b>Bit</b>	<b>7</b>	<b>6</b>	<b>5</b>	<b>4</b>	<b>3</b>	<b>2</b>	<b>1</b>	<b>0</b>
<b>Name</b>	0	0	0	ADC_DMARST	0	0	ADC_DMAAUTOWRAP	ADC_DMALOAD

Address: 0x4000D010 Reset: 0x0

Bitname	Bitfield	Access	Description
ADC_DMARST	[4]	W	Write 1 to reset the ADC DMA. This bit auto-clears.
ADC_DMAAUTOWRAP	[1]	RW	Selects DMA mode. 0: Linear mode, the DMA stops when the buffer is full. 1: Auto-wrap mode, the DMA output wraps back to the start when the buffer is full.
ADC_DMALOAD	[0]	RW	Loads the DMA buffer. Write 1 to start DMA (writing 0 has no effect). Cleared when DMA starts or is reset.

**Register 10.6. ADC\_DMASTAT: ADC DMA Status Register**

<b>Bit</b>	<b>31</b>	<b>30</b>	<b>29</b>	<b>28</b>	<b>27</b>	<b>26</b>	<b>25</b>	<b>24</b>
<b>Name</b>	0	0	0	0	0	0	0	0
<b>Bit</b>	<b>23</b>	<b>22</b>	<b>21</b>	<b>20</b>	<b>19</b>	<b>18</b>	<b>17</b>	<b>16</b>
<b>Name</b>	0	0	0	0	0	0	0	0
<b>Bit</b>	<b>15</b>	<b>14</b>	<b>13</b>	<b>12</b>	<b>11</b>	<b>10</b>	<b>9</b>	<b>8</b>
<b>Name</b>	0	0	0	0	0	0	0	0
<b>Bit</b>	<b>7</b>	<b>6</b>	<b>5</b>	<b>4</b>	<b>3</b>	<b>2</b>	<b>1</b>	<b>0</b>
<b>Name</b>	0	0	0	0	0	0	ADC_DMAOVF	ADC_DMAACT

Address: 0x4000D014 Reset: 0x0

Bitname	Bitfield	Access	Description
ADC_DMAOVF	[1]	R	DMA overflow: occurs when an ADC result is ready and the DMA is not active. Cleared by DMA reset.
ADC_DMAACT	[0]	R	DMA status: reads 1 if DMA is active.



## Register 10.7. ADC\_DMABEG: ADC DMA Begin Address Register

Bit	31	30	29	28	27	26	25	24
Name	0	0	1	0	0	0	0	0
Bit	23	22	21	20	19	18	17	16
Name	0	0	0	0	0	0	0	0
Bit	15	14	13	12	11	10	9	8
Name	0	0	ADC_DMABEG					
Bit	7	6	5	4	3	2	1	0
Name	ADC_DMABEG							

Address: 0x4000D018 Reset: 0x20000000

Bitname	Bitfield	Access	Description
ADC_DMABEG	[13:0]	RW	ADC buffer start address. Caution: this must be an even address - the least significant bit of this register is fixed at zero by hardware.

## Register 10.8. ADC\_DMASIZE: ADC DMA Buffer Size Register

Bit	31	30	29	28	27	26	25	24
Name	0	0	0	0	0	0	0	0
Bit	23	22	21	20	19	18	17	16
Name	0	0	0	0	0	0	0	0
Bit	15	14	13	12	11	10	9	8
Name	0	0	0	ADC_DMASIZE_FIELD				
Bit	7	6	5	4	3	2	1	0
Name	ADC_DMASIZE_FIELD							

Address: 0x4000D01C Reset: 0x0

Bitname	Bitfield	Access	Description
ADC_DMASIZE_FIELD	[12:0]	RW	ADC buffer size. This is the number of 16-bit ADC conversion results the buffer can hold, not its length in bytes. (The length in bytes is twice this value.)

**Register 10.9. ADC\_DMACUR: ADC DMA Current Address Register**

<b>Bit</b>	<b>31</b>	<b>30</b>	<b>29</b>	<b>28</b>	<b>27</b>	<b>26</b>	<b>25</b>	<b>24</b>	
<b>Name</b>	0	0	1	0	0	0	0	0	
<b>Bit</b>	<b>23</b>	<b>22</b>	<b>21</b>	<b>20</b>	<b>19</b>	<b>18</b>	<b>17</b>	<b>16</b>	
<b>Name</b>	0	0	0	0	0	0	0	0	
<b>Bit</b>	<b>15</b>	<b>14</b>	<b>13</b>	<b>12</b>	<b>11</b>	<b>10</b>	<b>9</b>	<b>8</b>	
<b>Name</b>	0	0	ADC_DMACUR_FIELD						
<b>Bit</b>	<b>7</b>	<b>6</b>	<b>5</b>	<b>4</b>	<b>3</b>	<b>2</b>	<b>1</b>	<b>0</b>	
<b>Name</b>	ADC_DMACUR_FIELD								0

Address: 0x4000D020 Reset: 0x20000000

Bitname	Bitfield	Access	Description
ADC_DMACUR_FIELD	[13:1]	R	Current DMA address: the location that will be written next by the DMA.

**Register 10.10. ADC\_DMACNT: ADC DMA Count Register**

<b>Bit</b>	<b>31</b>	<b>30</b>	<b>29</b>	<b>28</b>	<b>27</b>	<b>26</b>	<b>25</b>	<b>24</b>	
<b>Name</b>	0	0	0	0	0	0	0	0	
<b>Bit</b>	<b>23</b>	<b>22</b>	<b>21</b>	<b>20</b>	<b>19</b>	<b>18</b>	<b>17</b>	<b>16</b>	
<b>Name</b>	0	0	0	0	0	0	0	0	
<b>Bit</b>	<b>15</b>	<b>14</b>	<b>13</b>	<b>12</b>	<b>11</b>	<b>10</b>	<b>9</b>	<b>8</b>	
<b>Name</b>	0	0	0	ADC_DMACNT_FIELD					
<b>Bit</b>	<b>7</b>	<b>6</b>	<b>5</b>	<b>4</b>	<b>3</b>	<b>2</b>	<b>1</b>	<b>0</b>	
<b>Name</b>	ADC_DMACNT_FIELD								

Address: 0x4000D024 Reset: 0x0

Bitname	Bitfield	Access	Description
ADC_DMACNT_FIELD	[12:0]	R	DMA count: the number of 16-bit conversion results that have been written to the buffer.

# EM341

## Register 10.11. INT\_ADCFLAG: ADC Interrupt Flag Register

<b>Bit</b>	<b>31</b>	<b>30</b>	<b>29</b>	<b>28</b>	<b>27</b>	<b>26</b>	<b>25</b>	<b>24</b>
<b>Name</b>	0	0	0	0	0	0	0	0
<b>Bit</b>	<b>23</b>	<b>22</b>	<b>21</b>	<b>20</b>	<b>19</b>	<b>18</b>	<b>17</b>	<b>16</b>
<b>Name</b>	0	0	0	0	0	0	0	0
<b>Bit</b>	<b>15</b>	<b>14</b>	<b>13</b>	<b>12</b>	<b>11</b>	<b>10</b>	<b>9</b>	<b>8</b>
<b>Name</b>	0	0	0	0	0	0	0	0
<b>Bit</b>	<b>7</b>	<b>6</b>	<b>5</b>	<b>4</b>	<b>3</b>	<b>2</b>	<b>1</b>	<b>0</b>
<b>Name</b>	0	0	0	INT_ADCOVF	INT_ADCSAT	INT_ADCULDFULL	INT_ADCULDHALF	INT_ADCFLAGRSVD

Address: 0x4000A810 Reset: 0x0

Bitname	Bitfield	Access	Description
INT_ADCOVF	[4]	RW	DMA buffer overflow interrupt pending.
INT_ADCSAT	[3]	RW	Gain correction saturation interrupt pending.
INT_ADCULDFULL	[2]	RW	DMA buffer full interrupt pending.
INT_ADCULDHALF	[1]	RW	DMA buffer half full interrupt pending.
INT_ADCDATA	[0]	RW	ADC_DATA register has data interrupt pending.

## Register 10.12. INT\_ADCCFG: ADC Interrupt Configuration Register

<b>Bit</b>	<b>31</b>	<b>30</b>	<b>29</b>	<b>28</b>	<b>27</b>	<b>26</b>	<b>25</b>	<b>24</b>
<b>Name</b>	0	0	0	0	0	0	0	0
<b>Bit</b>	<b>23</b>	<b>22</b>	<b>21</b>	<b>20</b>	<b>19</b>	<b>18</b>	<b>17</b>	<b>16</b>
<b>Name</b>	0	0	0	0	0	0	0	0
<b>Bit</b>	<b>15</b>	<b>14</b>	<b>13</b>	<b>12</b>	<b>11</b>	<b>10</b>	<b>9</b>	<b>8</b>
<b>Name</b>	0	0	0	0	0	0	0	0
<b>Bit</b>	<b>7</b>	<b>6</b>	<b>5</b>	<b>4</b>	<b>3</b>	<b>2</b>	<b>1</b>	<b>0</b>
<b>Name</b>	0	0	0	INT_ADCOVF	INT_ADCSAT	INT_ADCULDFULL	INT_ADCULDHALF	INT_ADCCFGRSVD

Address: 0x4000A850 Reset: 0x0

Bitname	Bitfield	Access	Description
INT_ADCOVF	[4]	RW	DMA buffer overflow interrupt enable.
INT_ADCSAT	[3]	RW	Gain correction saturation interrupt enable.
INT_ADCULDFULL	[2]	RW	DMA buffer full interrupt enable.
INT_ADCULDHALF	[1]	RW	DMA buffer half full interrupt enable.
INT_ADCDATA	[0]	RW	ADC_DATA register has data interrupt enable.

## 9. Interrupt System

The EM341's interrupt system is composed of two parts: a standard ARM® Cortex™-M3 Nested Vectored Interrupt Controller (NVIC) that provides top-level interrupts, and a proprietary Event Manager (EM) that provides second-level interrupts. The NVIC and EM provide a simple hierarchy. All second-level interrupts from the EM feed into top-level interrupts in the NVIC. This two-level hierarchy allows for both fine granular control of interrupt sources and coarse granular control over entire peripherals, while allowing peripherals to have their own interrupt vector.

"9.1. Nested Vectored Interrupt Controller (NVIC)" on page 100 provides a description of the NVIC and an overview of the exception table (ARM nomenclature refers to interrupts as exceptions). "9.2. Event Manager" on page 102 provides a more detailed description of the Event Manager including a table of all top-level peripheral interrupts and their second-level interrupt sources.

In practice, top-level peripheral interrupts are only used to enable or disable interrupts for an entire peripheral. Second-level interrupts originate from hardware sources, and therefore are the main focus of applications using interrupts.

### 9.1. Nested Vectored Interrupt Controller (NVIC)

The ARM® Cortex™-M3 Nested Vectored Interrupt Controller (NVIC) facilitates low-latency exception and interrupt handling. The NVIC and the processor core interface are closely coupled, which enables low-latency interrupt processing and efficient processing of late-arriving interrupts. The NVIC also maintains knowledge of the stacked (nested) interrupts to enable tail-chaining of interrupts.

The ARM® Cortex™-M3 NVIC contains 10 standard interrupts that are related to chip and CPU operation and management. In addition to the 10 standard interrupts, it contains 17 individually vectored peripheral interrupts specific to the EM341.

The NVIC defines a list of exceptions. These exceptions include not only traditional peripheral interrupts, but also more specialized events such as faults and CPU reset. In the ARM® Cortex™-M3 NVIC, a CPU reset event is considered an exception of the highest priority, and the stack pointer is loaded from the first position in the NVIC exception table. The NVIC exception table defines all exceptions and their position, including peripheral interrupts. The position of each exception is important since it directly translates to the location of a 32-bit interrupt vector for each interrupt, and defines the hardware priority of exceptions. Each exception in the table is a 32-bit address that is loaded into the program counter when that exception occurs. Table 9.1 lists the entire exception table. Exceptions 0 (stack pointer) through 15 (SysTick) are part of the standard ARM® Cortex™-M3 NVIC, while exceptions 16 (Timer 1) through 32 (Debug) are the peripheral interrupts specific to the EM341 peripherals. The peripheral interrupts are listed in greater detail in Table 9.2.

Table 9.1. NVIC Exception Table

Exception	Position	Description
—	0	Stack top is loaded from first entry of vector table on reset.
Reset	1	Invoked on power up and warm reset. On first instruction, drops to lowest priority (Thread mode). Asynchronous.
NMI	2	Cannot be stopped or preempted by any exception but reset. Asynchronous.
Hard Fault	3	All classes of fault, when the fault cannot activate because of priority or the Configurable Fault handler has been disabled. Synchronous.
Memory Fault	4	MPU mismatch, including access violation and no match. Synchronous.
Bus Fault	5	Pre-fetch, memory access, and other address/memory-related faults. Synchronous when precise and asynchronous when imprecise.
Usage Fault	6	Usage fault, such as “undefined instruction executed” or “illegal state transition attempt”. Synchronous.
—	7–10	Reserved.
SVCcall	11	System service call with SVC instruction. Synchronous.
Debug Monitor	12	Debug monitor, when not halting. Synchronous, but only active when enabled. It does not activate if lower priority than the current activation.
—	13	Reserved.
PendSV	14	Pendable request for system service. Asynchronous and only pended by software.
SysTick	15	System tick timer has fired. Asynchronous.
Timer 1	16	Timer 1 peripheral interrupt..
Timer 2	17	Timer 2 peripheral interrupt.
Management	18	Management peripheral interrupt.
Baseband	19	Baseband peripheral interrupt.
Sleep Timer	20	Sleep Timer peripheral interrupt.
Serial Controller 1	21	Serial Controller 1 peripheral interrupt.
Serial Controller 2	22	Serial Controller 2 peripheral interrupt.
Security	23	Security peripheral interrupt.
MAC Timer	24	MAC Timer peripheral interrupt.
MAC Transmit	25	MAC Transmit peripheral interrupt.
MAC Receive	26	MAC Receive peripheral interrupt.
ADC	27	ADC peripheral interrupt.
IRQA	28	IRQA peripheral interrupt.
IRQB	29	IRQB peripheral interrupt.
IRQC	30	IRQC peripheral interrupt.
IRQD	31	IRQD peripheral interrupt.
Debug	32	Debug peripheral interrupt.

The NVIC also contains a software-configurable interrupt prioritization mechanism. The Reset, NMI, and Hard Fault exceptions, in that order, are always the highest priority, and are not software-configurable. All other exceptions can be assigned a 5-bit priority number, with low values representing higher priority. If any exceptions have the same software-configurable priority, then the NVIC uses the hardware-defined priority. The hardware-defined priority number is the same as the position of the exception in the exception table. For example, if IRQA and IRQB both fire at the same time and have the same software-defined priority, the NVIC handles IRQA, with priority number 28, first because it has a higher hardware priority than IRQB with priority number 29.

The top-level interrupts are controlled through five ARM<sup>®</sup> CortexTM-M3 NVIC registers: INT\_CFGSET, INT\_CFGCLR, INT\_PENDSET, INT\_PENDCLR, and INT\_ACTIVE. Writing 0 into any bit in any of these five registers is ineffective.

- INT\_CFGSET—Writing 1 to a bit in INT\_CFGSET enables that top-level interrupt.
- INT\_CFGCLR—Writing 1 to a bit in INT\_CFGCLR disables that top-level interrupt.
- INT\_PENDSET—Writing 1 to a bit in INT\_PENDSET triggers that top-level interrupt.
- INT\_PENDCLR—Writing 1 to a bit in INT\_PENDCLR clears that top-level interrupt.
- INT\_ACTIVE cannot be written to and is used for indicating which interrupts are currently active.

INT\_PENDSET and INT\_PENDCLR set and clear a simple latch; INT\_CFGSET and INT\_CFGCLR set and clear a mask on the output of the latch. Interrupts may be pended and cleared at any time, but any pended interrupt will not be taken unless the corresponding mask (INT\_CFGSET) is set, which allows that interrupt to propagate. If an INT\_CFGSET bit is set and the corresponding INT\_PENDSET bit is set, then the interrupt will propagate and be taken. If INT\_CFGSET is set after INT\_PENDSET is set, then the interrupt will also propagate and be taken. Interrupt flags (signals) from the top-level interrupts are level-sensitive.

The second-level interrupt registers, which provide control of the second-level Event Manager peripheral interrupts, are described in “9.2. Event Manager”.

For further information on the NVIC and ARM<sup>®</sup> CortexTM-M3 exceptions, refer to the ARM<sup>®</sup> CortexTM-M3 Technical Reference Manual and the ARM ARMv7-M Architecture Reference Manual.

## 9.2. Event Manager

While the standard ARM<sup>®</sup> CortexTM-M3 Nested Vectored Interrupt Controller provides top-level interrupts into the CPU, the proprietary Event Manager provides second-level interrupts. The Event Manager takes a large variety of hardware interrupt sources from the peripherals and merges them into a smaller group of interrupts in the NVIC. Effectively, all second-level interrupts from a peripheral are “ORd” together into a single interrupt in the NVIC. In addition, the Event Manager provides missed indicators for the top-level peripheral interrupts with the register INT\_MISS.

The description of each peripheral's interrupt configuration and flag registers can be found in the chapters of this datasheet describing each peripheral. Figure 9.1 shows the Peripheral Interrupts Block Diagram.

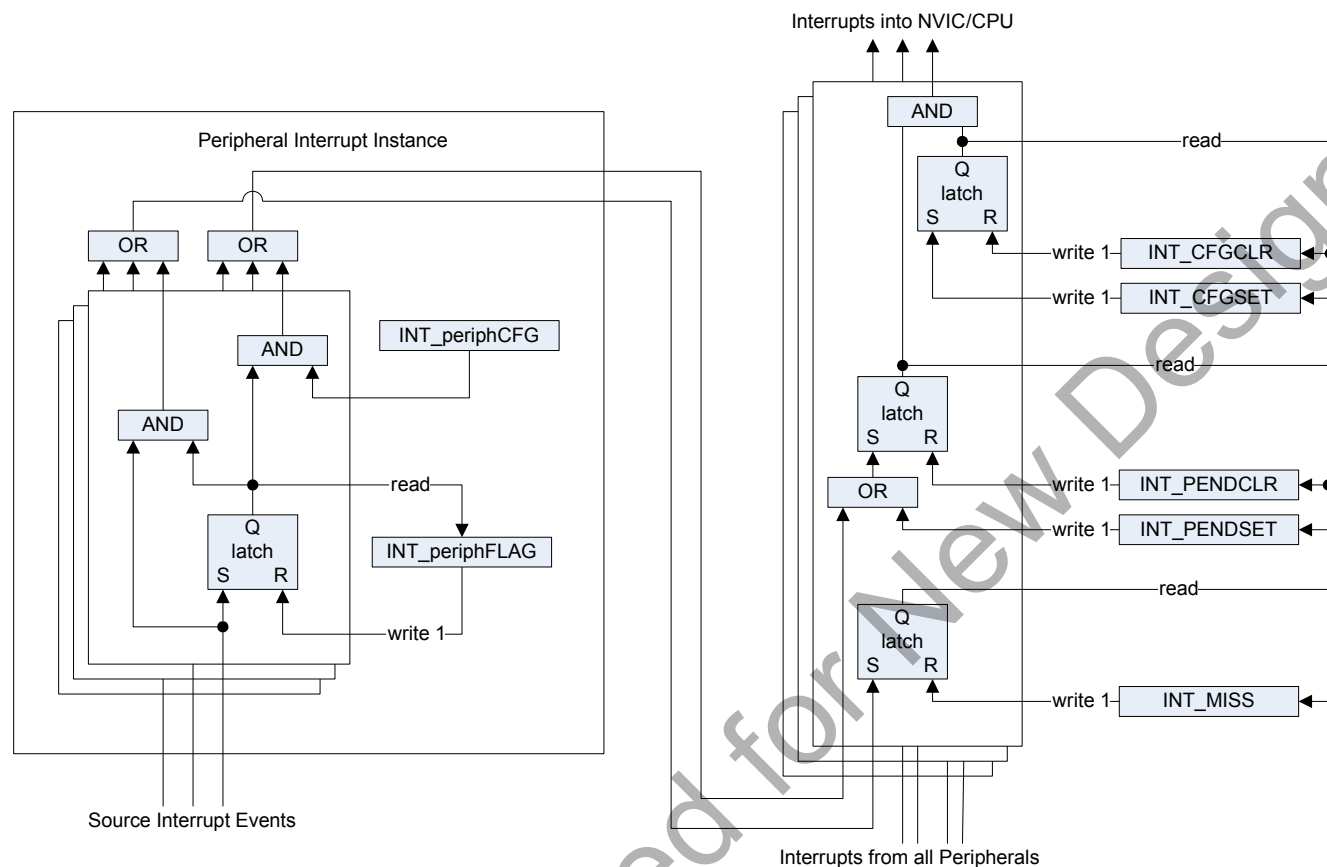

**Figure 9.1. Peripheral Interrupts Block Diagram**

Given a peripheral, “periph”, the Event Manager registers (INT\_periphCFG and INT\_periphFLAG) follow the form:

- INT\_periphCFG enables and disables second-level interrupts. Writing 1 to a bit in the INT\_periphCFG register enables the second-level interrupt. Writing 0 to a bit in the INT\_periphCFG register disables it. The INT\_periphCFG register behaves like a mask, and is responsible for allowing the INT\_periphFLAG bits to propagate into the top-level NVIC interrupts.
- INT\_periphFLAG indicates second-level interrupts that have occurred. Writing 1 to a bit in a INT\_periphFLAG register clears the second-level interrupt. Writing 0 to any bit in the INT\_periphFLAG register is ineffective. The INT\_periphFLAG register is always active and may be set or cleared at any time, meaning if any second-level interrupt occurs, then the corresponding bit in the INT\_periphFLAG register is set regardless of the state of INT\_periphCFG.

If a bit in the INT\_periphCFG register is set after the corresponding bit in the INT\_periphFLAG register is set then the second-level interrupt propagates into the top-level interrupts. The interrupt flags (signals) from the second-level interrupts into the top-level interrupts are level-sensitive. If a top-level NVIC interrupt is driven by a second-level EM interrupt, then the top-level NVIC interrupt cannot be cleared until all second-level EM interrupts are cleared.

The INT\_periphFLAG register bits are designed to remain set if the second-level interrupt event re-occurs at the same moment as the INT\_periphFLAG register bit is being cleared. This ensures the re-occurring second-level interrupt event is not missed.

If another enabled second-level interrupt event of the same type occurs before the first interrupt event is cleared, the second interrupt event is lost because no counting or queuing is used. However, this condition is detected and stored in the top-level INT\_MISS register to facilitate software detection of such problems. The INT\_MISS register is “acknowledged” in the same way as the INT\_periphFLAG register-by writing a 1 into the corresponding bit to be cleared.

# EM341

Table 9.2 provides a map of all peripheral interrupts. This map lists the top-level NVIC Interrupt bits and, if there is one, the corresponding second-level EM Interrupt register bits that feed the top-level interrupts.

**Table 9.2. NVIC and EM Peripheral Interrupt Map**

NVIC Interrupt (Top-Level)		EM Interrupt (Second-Level)		NVIC Interrupt (Top-Level)		EM Interrupt (Second-Level)	
16	INT_DEBUG			5	INT_SC1	INT_SC1FLAG register	
15	INT_IRQD					14	INT_SC1PARERR
14	INT_IRQC					13	INT_SC1FRMERR
13	INT_IRQB					12	INT_SCTXULDB
12	INT_IRQA					11	INT_SCTXULDA
11	INT_ADC	INT_ADCFLAG register				10	INT_SCRXULDB
		4	INT_ADCOVF			9	INT_SCRXULDA
		3	INT_ADCSAT			8	INT_SCNAK
		2	INT_ADCULDFULL			7	INT_SCCDMFIN
		1	INT_ADCULDHAF			6	INT_SCTXFIN
		0	INT_ADCDATA			5	INT_SCRXFIN
10	INT_MACRX					4	INT_SCTXUND
9	INT_MACTX					3	INT_SCRXOVF
8	INT_MACTMR					2	INT_SCTXIDLE
7	INT_SEC					1	INT_SCTXFREE
6	INT_SC2	INT_SC2FLAG register				0	INT_SCRXVAL
		12	INT_SCTXULDB	4	INT_SLEEPTMR		
		11	INT_SCTXULDA	3	INT_BB		
		10	INT_SCRXULDB	2	INT_MGMT		
		9	INT_SCRXULDA	1	INT_TMR2	INT_TMR2FLAG register	
		8	INT_SCNAK			6	INT_TMRRTIF
		7	INT_SCCDMFIN			4	INT_TMRCC4IF
		6	INT_SCTXFIN			3	INT_TMRCC3IF
		5	INT_SCRXFIN			2	INT_TMRCC2IF
		4	INT_SCTXUND			1	INT_TMRCC1IF
		3	INT_SCRXOVF			0	INT_TMRUIF
		2	INT_SCTXIDLE	0	INT_TMR1	INT_TMR1FLAG register	
		1	INT_SCTXFREE			6	INT_TMRRTIF
		0	INT_SCRXVAL			4	INT_TMRCC4IF
						3	INT_TMRCC3IF
						2	INT_TMRCC2IF
						1	INT_TMRCC1IF
						0	INT_TMRUIF



### 9.3. Non-Maskable Interrupt (NMI)

The non-maskable interrupt (NMI) is a special case. Despite being one of the 10 standard ARM<sup>®</sup> CortexTM-M3 NVIC interrupts, it is sourced from the Event Manager like a peripheral interrupt. The NMI has two second-level sources; failure of the 24 MHz crystal and watchdog low water mark.

1. Failure of the 24 MHz crystal: If the EM341's main clock, SYSCLK, is operating from the 24 MHz crystal and the crystal fails, the EM341 detects the failure and automatically switches to the internal 12 MHz RC clock. When this failure detection and switch has occurred, the EM341 triggers the CLK24M\_FAIL second-level interrupt, which then triggers the NMI.
2. Watchdog low water mark: If the EM341's watchdog is active and the watchdog counter has not been reset for nominally 1.792 s, the watchdog triggers the WATCHDOG\_INT second-level interrupt, which then triggers the NMI.

### 9.4. Faults

Four of the exceptions in the NVIC are faults: Hard Fault, Memory Fault, Bus Fault, and Usage Fault. Of these, three (Hard Fault, Memory Fault, and Usage Fault) are standard ARM<sup>®</sup> CortexTM-M3 exceptions.

The Bus Fault, though, is derived from EM341-specific sources. The Bus Fault sources are recorded in the SCS\_AFSR register. Note that it is possible for one access to set multiple SCS\_AFSR bits. Also note that MPU configurations could prevent most of these bus fault accesses from occurring, with the advantage that illegal writes are made precise faults. The four bus faults are:

- **WRONGSIZE**—Generated by an 8-bit or 16-bit read or write of an APB peripheral register. This fault can also result from an unaligned 32-bit access.
- **PROTECTED**—Generated by a user mode (unprivileged) write to a system APB or AHB peripheral or protected RAM (see "5.2.2.3. RAM Memory Protection" on page 31).
- **RESERVED**—Generated by a read or write to an address within an APB peripheral's 4 kB block range, but the address is above the last physical register in that block range. Also generated by a read or write to an address above the top of RAM or flash.
- **MISSED**—Generated by a second SCS\_AFSR fault. In practice, this bit is not seen since a second fault also generates a hard fault, and the hard fault preempts the bus fault.

## 9.5. Registers

**Register 9.1. INT\_CFGSET: Top-Level Set Interrupts Configuration Register**

<b>Bit</b>	<b>31</b>	<b>30</b>	<b>29</b>	<b>28</b>	<b>27</b>	<b>26</b>	<b>25</b>	<b>24</b>
<b>Name</b>	0	0	0	0	0	0	0	0
<b>Bit</b>	<b>23</b>	<b>22</b>	<b>21</b>	<b>20</b>	<b>19</b>	<b>18</b>	<b>17</b>	<b>16</b>
<b>Name</b>	0	0	0	0	0	0	0	INT_DEBUG
<b>Bit</b>	<b>15</b>	<b>14</b>	<b>13</b>	<b>12</b>	<b>11</b>	<b>10</b>	<b>9</b>	<b>8</b>
<b>Name</b>	INT_IRQD	INT_IRQC	INT_IRQB	INT_IRQA	INT_ADC	INT_MACRX	INT_MACTX	INT_MACTMR
<b>Bit</b>	<b>7</b>	<b>6</b>	<b>5</b>	<b>4</b>	<b>3</b>	<b>2</b>	<b>1</b>	<b>0</b>
<b>Name</b>	INT_SEC	INT_SC2	INT_SC1	INT_SLEEPTMR	INT_BB	INT_MGMT	INT_TIM2	INT_TIM1

Address: 0xE00E100; Reset: 0x0

Bit Name	Bit Field	Access	Description
INT_DEBUG	[16]	RW	Write 1 to enable debug interrupt. (Writing 0 has no effect.)
INT_IRQD	[15]	RW	Write 1 to enable IRQD interrupt. (Writing 0 has no effect.)
INT_IRQC	[14]	RW	Write 1 to enable IRQC interrupt. (Writing 0 has no effect.)
INT_IRQB	[13]	RW	Write 1 to enable IRQB interrupt. (Writing 0 has no effect.)
INT_IRQA	[12]	RW	Write 1 to enable IRQA interrupt. (Writing 0 has no effect.)
INT_ADC	[11]	RW	Write 1 to enable ADC interrupt. (Writing 0 has no effect.)
INT_MACRX	[10]	RW	Write 1 to enable MAC receive interrupt. (Writing 0 has no effect.)
INT_MACTX	[9]	RW	Write 1 to enable MAC transmit interrupt. (Writing 0 has no effect.)
INT_MACTMR	[8]	RW	Write 1 to enable MAC timer interrupt. (Writing 0 has no effect.)
INT_SEC	[7]	RW	Write 1 to enable security interrupt. (Writing 0 has no effect.)
INT_SC2	[6]	RW	Write 1 to enable serial controller 2 interrupt. (Writing 0 has no effect.)
INT_SC1	[5]	RW	Write 1 to enable serial controller 1 interrupt. (Writing 0 has no effect.)
INT_SLEEPTMR	[4]	RW	Write 1 to enable sleep timer interrupt. (Writing 0 has no effect.)
INT_BB	[3]	RW	Write 1 to enable baseband interrupt. (Writing 0 has no effect.)
INT_MGMT	[2]	RW	Write 1 to enable management interrupt. (Writing 0 has no effect.)
INT_TIM2	[1]	RW	Write 1 to enable timer 2 interrupt. (Writing 0 has no effect.)
INT_TIM1	[0]	RW	Write 1 to enable timer 1 interrupt. (Writing 0 has no effect.)

**Register 9.2. INT\_CFGCLR: Top-Level Clear Interrupts Configuration Register**

<b>Bit</b>	<b>31</b>	<b>30</b>	<b>29</b>	<b>28</b>	<b>27</b>	<b>26</b>	<b>25</b>	<b>24</b>
<b>Name</b>	0	0	0	0	0	0	0	0
<b>Bit</b>	<b>23</b>	<b>22</b>	<b>21</b>	<b>20</b>	<b>19</b>	<b>18</b>	<b>17</b>	<b>16</b>
<b>Name</b>	0	0	0	0	0	0	0	INT_DEBUG
<b>Bit</b>	<b>15</b>	<b>14</b>	<b>13</b>	<b>12</b>	<b>11</b>	<b>10</b>	<b>9</b>	<b>8</b>
<b>Name</b>	INT_IRQD	INT_IRQC	INT_IRQB	INT_IRQA	INT_ADC	INT_MACRX	INT_MACTX	INT_MACTMR
<b>Bit</b>	<b>7</b>	<b>6</b>	<b>5</b>	<b>4</b>	<b>3</b>	<b>2</b>	<b>1</b>	<b>0</b>
<b>Name</b>	INT_SEC	INT_SC2	INT_SC1	INT_SLEEPTMR	INT_BB	INT_MGMT	INT_TIM2	INT_TIM1

Address: 0xE000E180 Reset: 0x0

Bitname	Bitfield	Access	Description
INT_DEBUG	[16]	RW	Write 1 to disable debug interrupt. (Writing 0 has no effect.)
INT_IRQD	[15]	RW	Write 1 to disable IRQD interrupt. (Writing 0 has no effect.)
INT_IRQC	[14]	RW	Write 1 to disable IRQC interrupt. (Writing 0 has no effect.)
INT_IRQB	[13]	RW	Write 1 to disable IRQB interrupt. (Writing 0 has no effect.)
INT_IRQA	[12]	RW	Write 1 to disable IRQA interrupt. (Writing 0 has no effect.)
INT_ADC	[11]	RW	Write 1 to disable ADC interrupt. (Writing 0 has no effect.)
INT_MACRX	[10]	RW	Write 1 to disable MAC receive interrupt. (Writing 0 has no effect.)
INT_MACTX	[9]	RW	Write 1 to disable MAC transmit interrupt. (Writing 0 has no effect.)
INT_MACTMR	[8]	RW	Write 1 to disable MAC timer interrupt. (Writing 0 has no effect.)
INT_SEC	[7]	RW	Write 1 to disable security interrupt. (Writing 0 has no effect.)
INT_SC2	[6]	RW	Write 1 to disable serial controller 2 interrupt. (Writing 0 has no effect.)
INT_SC1	[5]	RW	Write 1 to disable serial controller 1 interrupt. (Writing 0 has no effect.)
INT_SLEEPTMR	[4]	RW	Write 1 to disable sleep timer interrupt. (Writing 0 has no effect.)
INT_BB	[3]	RW	Write 1 to disable baseband interrupt. (Writing 0 has no effect.)
INT_MGMT	[2]	RW	Write 1 to disable management interrupt. (Writing 0 has no effect.)
INT_TIM2	[1]	RW	Write 1 to disable timer 2 interrupt. (Writing 0 has no effect.)
INT_TIM1	[0]	RW	Write 1 to disable timer 1 interrupt. (Writing 0 has no effect.)

**Register 9.3. INT\_PENDSET: Top-Level Set Interrupts Pending Register**

<b>Bit</b>	<b>31</b>	<b>30</b>	<b>29</b>	<b>28</b>	<b>27</b>	<b>26</b>	<b>25</b>	<b>24</b>
<b>Name</b>	0	0	0	0	0	0	0	0
<b>Bit</b>	<b>23</b>	<b>22</b>	<b>21</b>	<b>20</b>	<b>19</b>	<b>18</b>	<b>17</b>	<b>16</b>
<b>Name</b>	0	0	0	0	0	0	0	INT_DEBUG
<b>Bit</b>	<b>15</b>	<b>14</b>	<b>13</b>	<b>12</b>	<b>11</b>	<b>10</b>	<b>9</b>	<b>8</b>
<b>Name</b>	INT_IRQD	INT_IRQC	INT_IRQB	INT_IRQA	INT_ADC	INT_MACRX	INT_MACTX	INT_MACTMR
<b>Bit</b>	<b>7</b>	<b>6</b>	<b>5</b>	<b>4</b>	<b>3</b>	<b>2</b>	<b>1</b>	<b>0</b>
<b>Name</b>	INT_SEC	INT_SC2	INT_SC1	INT_SLEEPTMR	INT_BB	INT_MGMT	INT_TIM2	INT_TIM1

Address: 0xE000E200 Reset: 0x0

Bitname	Bitfield	Access	Description
INT_DEBUG	[16]	RW	Write 1 to pend debug interrupt. (Writing 0 has no effect.)
INT_IRQD	[15]	RW	Write 1 to pend IRQD interrupt. (Writing 0 has no effect.)
INT_IRQC	[14]	RW	Write 1 to pend IRQC interrupt. (Writing 0 has no effect.)
INT_IRQB	[13]	RW	Write 1 to pend IRQB interrupt. (Writing 0 has no effect.)
INT_IRQA	[12]	RW	Write 1 to pend IRQA interrupt. (Writing 0 has no effect.)
INT_ADC	[11]	RW	Write 1 to pend ADC interrupt. (Writing 0 has no effect.)
INT_MACRX	[10]	RW	Write 1 to pend MAC receive interrupt. (Writing 0 has no effect.)
INT_MACTX	[9]	RW	Write 1 to pend MAC transmit interrupt. (Writing 0 has no effect.)
INT_MACTMR	[8]	RW	Write 1 to pend MAC timer interrupt. (Writing 0 has no effect.)
INT_SEC	[7]	RW	Write 1 to pend security interrupt. (Writing 0 has no effect.)
INT_SC2	[6]	RW	Write 1 to pend serial controller 2 interrupt. (Writing 0 has no effect.)
INT_SC1	[5]	RW	Write 1 to pend serial controller 1 interrupt. (Writing 0 has no effect.)
INT_SLEEPTMR	[4]	RW	Write 1 to pend sleep timer interrupt. (Writing 0 has no effect.)
INT_BB	[3]	RW	Write 1 to pend baseband interrupt. (Writing 0 has no effect.)
INT_MGMT	[2]	RW	Write 1 to pend management interrupt. (Writing 0 has no effect.)
INT_TIM2	[1]	RW	Write 1 to pend timer 2 interrupt. (Writing 0 has no effect.)
INT_TIM1	[0]	RW	Write 1 to pend timer 1 interrupt. (Writing 0 has no effect.)

**Register 9.4. INT\_PENDCLR: Top-Level Clear Interrupts Pending Register**

<b>Bit</b>	<b>31</b>	<b>30</b>	<b>29</b>	<b>28</b>	<b>27</b>	<b>26</b>	<b>25</b>	<b>24</b>
<b>Name</b>	0	0	0	0	0	0	0	0
<b>Bit</b>	<b>23</b>	<b>22</b>	<b>21</b>	<b>20</b>	<b>19</b>	<b>18</b>	<b>17</b>	<b>16</b>
<b>Name</b>	0	0	0	0	0	0	0	INT_DEBUG
<b>Bit</b>	<b>15</b>	<b>14</b>	<b>13</b>	<b>12</b>	<b>11</b>	<b>10</b>	<b>9</b>	<b>8</b>
<b>Name</b>	INT_IRQD	INT_IRQC	INT_IRQB	INT_IRQA	INT_ADC	INT_MACRX	INT_MACTX	INT_MACTMR
<b>Bit</b>	<b>7</b>	<b>6</b>	<b>5</b>	<b>4</b>	<b>3</b>	<b>2</b>	<b>1</b>	<b>0</b>
<b>Name</b>	INT_SEC	INT_SC2	INT_SC1	INT_SLEEPTMR	INT_BB	INT_MGMT	INT_TIM2	INT_TIM1

Address: 0xE000E280 Reset: 0x0

Bitname	Bitfield	Access	Description
INT_DEBUG	[16]	RW	Write 1 to unpend debug interrupt. (Writing 0 has no effect.)
INT_IRQD	[15]	RW	Write 1 to unpend IRQD interrupt. (Writing 0 has no effect.)
INT_IRQC	[14]	RW	Write 1 to unpend IRQC interrupt. (Writing 0 has no effect.)
INT_IRQB	[13]	RW	Write 1 to unpend IRQB interrupt. (Writing 0 has no effect.)
INT_IRQA	[12]	RW	Write 1 to unpend IRQA interrupt. (Writing 0 has no effect.)
INT_ADC	[11]	RW	Write 1 to unpend ADC interrupt. (Writing 0 has no effect.)
INT_MACRX	[10]	RW	Write 1 to unpend MAC receive interrupt. (Writing 0 has no effect.)
INT_MACTX	[9]	RW	Write 1 to unpend MAC transmit interrupt. (Writing 0 has no effect.)
INT_MACTMR	[8]	RW	Write 1 to unpend MAC timer interrupt. (Writing 0 has no effect.)
INT_SEC	[7]	RW	Write 1 to unpend security interrupt. (Writing 0 has no effect.)
INT_SC2	[6]	RW	Write 1 to unpend serial controller 2 interrupt. (Writing 0 has no effect.)
INT_SC1	[5]	RW	Write 1 to unpend serial controller 1 interrupt. (Writing 0 has no effect.)
INT_SLEEPTMR	[4]	RW	Write 1 to unpend sleep timer interrupt. (Writing 0 has no effect.)
INT_BB	[3]	RW	Write 1 to unpend baseband interrupt. (Writing 0 has no effect.)
INT_MGMT	[2]	RW	Write 1 to unpend management interrupt. (Writing 0 has no effect.)
INT_TIM2	[1]	RW	Write 1 to unpend timer 2 interrupt. (Writing 0 has no effect.)
INT_TIM1	[0]	RW	Write 1 to unpend timer 1 interrupt. (Writing 0 has no effect.)

**Register 9.5. INT\_ACTIVE: Top-Level Active Interrupts Register**

<b>Bit</b>	<b>31</b>	<b>30</b>	<b>29</b>	<b>28</b>	<b>27</b>	<b>26</b>	<b>25</b>	<b>24</b>
<b>Name</b>	0	0	0	0	0	0	0	0
<b>Bit</b>	<b>23</b>	<b>22</b>	<b>21</b>	<b>20</b>	<b>19</b>	<b>18</b>	<b>17</b>	<b>16</b>
<b>Name</b>	0	0	0	0	0	0	0	INT_DEBUG
<b>Bit</b>	<b>15</b>	<b>14</b>	<b>13</b>	<b>12</b>	<b>11</b>	<b>10</b>	<b>9</b>	<b>8</b>
<b>Name</b>	INT_IRQD	INT_IRQC	INT_IRQB	INT_IRQA	INT_ADC	INT_MACRX	INT_MACTX	INT_MACTMR
<b>Bit</b>	<b>7</b>	<b>6</b>	<b>5</b>	<b>4</b>	<b>3</b>	<b>2</b>	<b>1</b>	<b>0</b>
<b>Name</b>	INT_SEC	INT_SC2	INT_SC1	INT_SLEEPTMR	INT_BB	INT_MGMT	INT_TIM2	INT_TIM1

Address: 0xE000E300 Reset: 0x0

Bitname	Bitfield	Access	Description
INT_DEBUG	[16]	R	Debug interrupt active.
INT_IRQD	[15]	R	IRQD interrupt active.
INT_IRQC	[14]	R	IRQC interrupt active.
INT_IRQB	[13]	R	IRQB interrupt active.
INT_IRQA	[12]	R	IRQA interrupt active.
INT_ADC	[11]	R	ADC interrupt active.
INT_MACRX	[10]	R	MAC receive interrupt active.
INT_MACTX	[9]	R	MAC transmit interrupt active.
INT_MACTMR	[8]	R	MAC timer interrupt active.
INT_SEC	[7]	R	Security interrupt active.
INT_SC2	[6]	R	Serial controller 2 interrupt active.
INT_SC1	[5]	R	Serial controller 1 interrupt active.
INT_SLEEPTMR	[4]	R	Sleep timer interrupt active.
INT_BB	[3]	R	Baseband interrupt active.
INT_MGMT	[2]	R	Management interrupt active.
INT_TIM2	[1]	R	Timer 2 interrupt active.
INT_TIM1	[0]	R	Timer 1 interrupt active.

**Register 9.6. INT\_MISS: Top-Level Missed Interrupts Register**

<b>Bit</b>	<b>31</b>	<b>30</b>	<b>29</b>	<b>28</b>	<b>27</b>	<b>26</b>	<b>25</b>	<b>24</b>
<b>Name</b>	0	0	0	0	0	0	0	0
<b>Bit</b>	<b>23</b>	<b>22</b>	<b>21</b>	<b>20</b>	<b>19</b>	<b>18</b>	<b>17</b>	<b>16</b>
<b>Name</b>	0	0	0	0	0	0	0	0
<b>Bit</b>	<b>15</b>	<b>14</b>	<b>13</b>	<b>12</b>	<b>11</b>	<b>10</b>	<b>9</b>	<b>8</b>
<b>Name</b>	INT_ MISSIRQD	INT_ MISSIRQC	INT_ MISSIRQB	INT_ MISSIRQA	INT_ MISSADC	INT_ MISSMACRX	INT_ MISSMACTX	INT_ MISSMACTMR
<b>Bit</b>	<b>7</b>	<b>6</b>	<b>5</b>	<b>4</b>	<b>3</b>	<b>2</b>	<b>1</b>	<b>0</b>
<b>Name</b>	INT_ MISSEC	INT_ MISSSC2	INT_ MISSSC1	INT_ MISSSLEEP	INT_ MISSBB	INT_ MISSMGMT	0	0

Address: 0x4000A820 Reset: 0x0

Bitname	Bitfield	Access	Description
INT_MISSIRQD	[15]	RW	IRQD interrupt missed.
INT_MISSIRQC	[14]	RW	IRQC interrupt missed.
INT_MISSIRQB	[13]	RW	IRQB interrupt missed.
INT_MISSIRQA	[12]	RW	IRQA interrupt missed.
INT_MISSADC	[11]	RW	ADC interrupt missed.
INT_MISSMACRX	[10]	RW	MAC receive interrupt missed.
INT_MISSMACTX	[9]	RW	MAC transmit interrupt missed.
INT_MISSMACTMR	[8]	RW	MAC Timer interrupt missed.
INT_MISSEC	[7]	RW	Security interrupt missed.
INT_MISSSC2	[6]	RW	Serial controller 2 interrupt missed.
INT_MISSSC1	[5]	RW	Serial controller 1 interrupt missed.
INT_MISSSLEEP	[4]	RW	Sleep timer interrupt missed.
INT_MISSBB	[3]	RW	Baseband interrupt missed.
INT_MISSMGMT	[2]	RW	Management interrupt missed.

**Register 9.7. SCS\_AFSR: Auxiliary Fault Status Register**

<b>Bit</b>	<b>31</b>	<b>30</b>	<b>29</b>	<b>28</b>	<b>27</b>	<b>26</b>	<b>25</b>	<b>24</b>
<b>Name</b>	0	0	0	0	0	0	0	0
<b>Bit</b>	<b>23</b>	<b>22</b>	<b>21</b>	<b>20</b>	<b>19</b>	<b>18</b>	<b>17</b>	<b>16</b>
<b>Name</b>	0	0	0	0	0	0	0	0
<b>Bit</b>	<b>15</b>	<b>14</b>	<b>13</b>	<b>12</b>	<b>11</b>	<b>10</b>	<b>9</b>	<b>8</b>
<b>Name</b>	0	0	0	0	0	0	0	0
<b>Bit</b>	<b>7</b>	<b>6</b>	<b>5</b>	<b>4</b>	<b>3</b>	<b>2</b>	<b>1</b>	<b>0</b>
<b>Name</b>	0	0	0	0	WRONGSIZE	PROTECTED	RESERVED	MISSED

Address: 0xE000ED3C Reset: 0x0

<b>Bitname</b>	<b>Bitfield</b>	<b>Access</b>	<b>Description</b>
WRONGSIZE	[3]	RW	A bus fault resulted from an 8-bit or 16-bit read or write of an APB peripheral register. This fault can also result from an unaligned 32-bit access.
PROTECTED	[2]	RW	A bus fault resulted from a user mode (unprivileged) write to a system APB or AHB peripheral or protected RAM.
RESERVED	[1]	RW	A bus fault resulted from a read or write to an address within an APB peripheral's 4 kB block range, but above the last physical register in that block. Can also result from a read or write to an address above the top of RAM or flash.
MISSED	[0]	RW	A bus fault occurred when a bit was already set in this register.



## 10. Trace Port Interface Unit (TPIU)

The EM341 integrates the standard ARM® Trace Port Interface Unit (TPIU). The TPIU receives a data stream from the on-chip trace data generated by the standard ARM® Instrument Trace Macrocell (ITM), buffers the data in a FIFO, formats the data, and serializes the data to be sent off-chip through alternate functions of the GPIO. Since the primary function of the TPIU is to provide a bridge between on-chip ARM system debug components and external GPIO, the TPIU itself does not generate data. Figure 10.1 illustrates the three primary components of the TPIU.

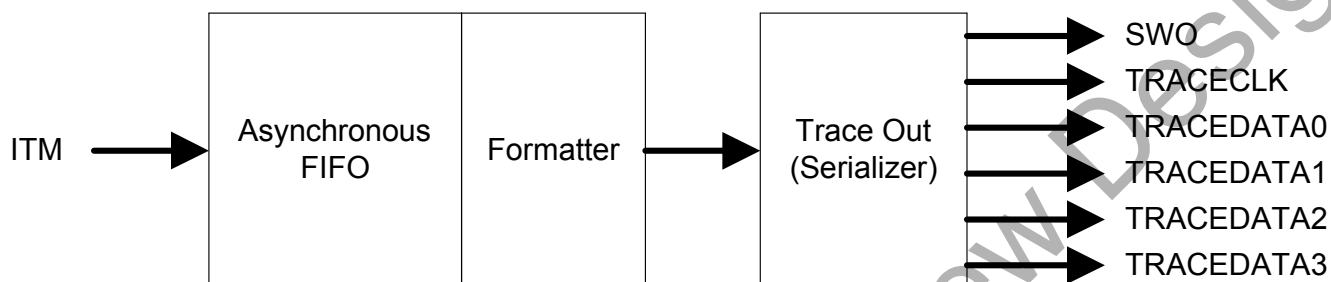

Figure 10.1. TPIU Block Diagram

The TPIU is composed of:

- **Asynchronous FIFO:** The asynchronous FIFO receives a data stream generated by the ITM and enables the trace data to be sent off-chip at a speed that is not dependent on the speed of the data source.
- **Formatter:** The formatter inserts source ID signals into the data packet stream so that trace data can be re-associated with its trace source. Since the EM341 has only one trace source, the ITM, it is not necessary to use the formatter, and, therefore, the formatter only adds overhead into the data stream. Since certain modes of the TPIU automatically enable the formatter, these modes should be avoided whenever possible.
- **Trace Out:** The trace out block serializes the data and sends it off-chip by the proper alternate output GPIO functions.

The six pins available to the TPIU are:

- SWO
- TRACECLK
- TRACEDATA0
- TRACEDATA1
- TRACEDATA2
- TRACEDATA3

Since these pins are alternate outputs of GPIO, refer to "17. Pin Definitions" on page 121 and "7. GPIO (General Purpose Input/Output)" on page 48 for complete pin descriptions and configurations.

### Notes:

1. The SWO alternate output is mirrored on GPIO PC1 and PC2.
2. GPIO PC1 shares both the SWO and TRACEDATA0 alternate outputs. This is possible because SWO and TRACEDATA0 are mutually exclusive, and only one may be selected at a time in the trace-out block.

The Ember software utilizes the TPIU to efficiently output debug data. Altering the TPIU configuration may conflict with Ember debug output.

For further information on the TPIU, contact Silicon Labs support for the ARM® Cortex™-M3 Technical Reference Manual, the ARM® CoreSight™ Components Technical Reference Manual, the ARM® v7-M Architecture Reference Manual, and the ARM® v7-M Architecture Application Level Reference Manual.

## 11. Instrumentation Trace Macrocell (ITM)

The EM341 integrates the standard ARM<sup>®</sup> Instrumentation Trace Macrocell (ITM). The ITM is an application-driven trace source that supports printf style debugging to trace software events and emits diagnostic system information from the ARM<sup>®</sup> Data Watchpoint and Trace (DWT). Software using the ITM generates Software Instrumentation Trace (SWIT). In addition, the ITM provides coarse-grained timestamp functionality. The ITM emits trace information as packets, and these packets are sent to the Trace Port Interface Unit (TPIU). Three sources can generate packets. If multiple sources generate packets at the same time, the ITM arbitrates the order in which the packets are output. The three sources, in decreasing order of priority, are:

- Software trace. Software can write directly to ITM stimulus registers, emitting packets.
- Hardware trace. The DWT generates packets that the ITM emits.
- Time stamping. Timestamps are emitted relative to packets, and the ITM contains a 21-bit counter to generate the timestamps.

The Ember software utilizes the ITM for efficiently generating debug data. Altering the ITM configuration may conflict with Ember debug output.

For further information on the ITM, contact Silicon Labs support for the ARM<sup>®</sup> Cortex™-M3 Technical Reference Manual, the ARM<sup>®</sup> CoreSight™ Components Technical Reference Manual, the ARM<sup>®</sup> v7-M Architecture Reference Manual, and the ARM<sup>®</sup> v7-M Architecture Application Level Reference Manual.

## 12. Data Watchpoint and Trace (DWT)

The EM341 integrates the standard ARM® Data Watchpoint and Trace (DWT). The DWT provides hardware support for profiling and debugging functionality. The DWT offers the following features:

- PC sampling
- Comparators to support:
  - Watchpoints - enters debug state
  - Data tracing
  - Cycle count matched PC sampling
- Exception trace support
- Instruction cycle count calculation support

Apart from exception tracing, DWT functionality is counter- or comparator-based. Watchpoint and data trace support use a set of compare, mask, and function registers. DWT-generated events result in one of two actions:

- Generation of a hardware event packet. Packets are generated and combined with software events and timestamp packets for transmission through the ITM/TPIU.
- A core halt - entry to debug state.

When exception tracing is enabled, the DWT emits an exception trace packet under the following conditions:

- Exception entry (from thread mode or pre-emption of a thread or handler).
- Exception exit when exiting a handler.
- Exception return when reentering a preempted thread or handler code sequence.

The DWT is designed for use with advanced profiling and debug tools, available from multiple vendors. Altering DWT configuration may conflict with the operation of advanced profiling and debug tools.

For further information on the DWT, contact Silicon Labs support for the ARM® Cortex™-M3 Technical Reference Manual, the ARM® CoreSight™ Components Technical Reference Manual, the ARM® v7-M Architecture Reference Manual, and the ARM® v7-M Architecture Application Level Reference Manual.

## 13. Flash Patch and Breakpoint (FPB)

The EM341 integrates the standard ARM® Flash Patch and Breakpoint (FPB). The FPB implements hardware breakpoints. The FPB also provides support for remapping of specific instruction or literal locations from flash memory to an address in RAM memory. The FPB contains:

- Two literal comparators for matching against literal loads from flash space and remapping to a corresponding RAM space.
- Six instruction comparators for matching against instruction fetches from flash space and remapping to a corresponding RAM space. Alternatively, the comparators can be individually configured to return a breakpoint instruction to the processor core on a match, implementing hardware breakpoint capability.

The FPB contains a global enable, but also individual enables for the eight comparators. If the comparison for an entry matches, the address is remapped to the address defined in the remap register plus an offset corresponding to the comparator that matched. Alternately, the address is remapped to a breakpoint instruction. The comparison happens on the fly, but the result of the comparison occurs too late to stop the original instruction fetch or literal load taking place from the flash space. The processor ignores this transaction, however, and only the remapped transaction is used.

Memory Protection Unit (MPU) lookups are performed for the original address, not the remapped address.

Unaligned literal accesses are not remapped. The original access to the bus takes place in this case.

The FPB is designed for use with advanced debug tools, available from multiple vendors. Altering the FPB configuration may conflict with the operation of advanced debug tools.

For further information on the FPB, contact Silicon Labs support for the ARM® Cortex™-M3 Technical Reference Manual, the ARM® CoreSight™ Components Technical Reference Manual, the ARM® v7-M Architecture Reference Manual, and the ARM® v7-M Architecture Application Level Reference Manual.

## 14. Integrated Voltage Regulator

The EM341 integrates two low dropout regulators to provide 1.8 V and 1.25 V power supplies as detailed in Table 14.1. The 1V8 regulator supplies the analog and memories, and the 1V25 regulator supplies the digital core. In deep sleep, the voltage regulators are disabled.

When enabled, the 1V8 regulator steps down the pads supply voltage (VDD\_PADS) from a nominal 3.0 V to 1.8 V. The regulator output pin (VREG\_OUT) must be decoupled externally with a suitable capacitor. VREG\_OUT should be connected to the 1.8 V supply pins VDDA, VDD\_RF, VDD\_VCO, VDD\_SYNT, VDD\_IF, and VDD\_MEM. The 1V8 regulator can supply a maximum of 50 mA.

When enabled, the 1V25 regulator steps down VDD\_PADS to 1.25 V. The regulator output pin (VDD\_CORE, Pin 17) must be decoupled externally with a suitable capacitor. It should connect to the other VDD\_CORE pin (Pin 44). The 1V25 regulator can supply a maximum of 10 mA.

The regulators are controlled by the digital portion of the chip as described in "6. System Modules" on page 33.

An example of decoupling capacitors and PCB layout can be found in the application notes (see the various Ember EM35x reference design documentation).

**Table 14.1. Integrated Voltage Regulator Specifications**

Spec Point	Min	Typ	Max	Units	Comments
Supply range for regulator	2.1		3.6	V	VDD_PADS
1V8 regulator output	-5%	1.8	+5%	V	Regulator output after initialization
1V8 regulator output after reset	-5%	1.75	+5%		Regulator output after reset
1V25 regulator output	-5%	1.25	+5%	V	Regulator output after initialization
1V25 regulator output after reset	-5%	1.45	+5%		Regulator output after reset
1V8 regulator capacitor		2.2		$\mu$ F	Low ESR tantalum capacitor ESR greater than 2 $\Omega$ ESR less than 10 $\Omega$ de-coupling less than 100 nF ceramic
1V25 regulator capacitor		1.0		$\mu$ F	Ceramic capacitor (0603)
1V8 regulator output current	0		50	mA	Regulator output current
1V25 regulator output current	0		10	mA	Regulator output current
No load current		600		$\mu$ A	No load current (bandgap and regulators)
1V8 regulator current limit		200		mA	Short circuit current limit
1V25 regulator current limit		25		mA	Short circuit current limit
1V8 regulator start-up time		50		$\mu$ s	0 V to POR threshold 2.2 $\mu$ F capacitor
1V25 regulator start-up time		50		$\mu$ s	0 V to POR threshold 1.0 $\mu$ F capacitor

## EM341

---

An external 1.8 V regulator may replace both internal regulators. The EM341 can control external regulators during deep sleep using open-drain GPIO PA7, as described in "7. GPIO (General Purpose Input/Output)" on page 48. The EM341 drives PA7 low during deep sleep to disable the external regulator, and an external pull-up is required to release this signal to indicate that supply voltage should be provided. Current consumption increases approximately 2 mA when using an external regulator. When using an external regulator, the internal regulators should be disabled through Ember software. The always-on domain needs to be minimally powered at 2.1 V and cannot be powered from the external 1.8 V regulator.

Not Recommended for New Designs

## 15. Serial Wire and JTAG (SWJ) Interface

The EM341 includes a standard Serial Wire and JTAG (SWJ) Interface. The SWJ is the primary debug and programming interface of the EM341. The SWJ gives debug tools access to the internal buses of the EM341 and allows for non-intrusive memory and register access as well as CPU halt-step style debugging. Therefore, any design implementing the EM341 should make the SWJ signals readily available.

Serial Wire is an ARM<sup>®</sup> standard, bidirectional, two-wire protocol designed to replace JTAG and provides all the normal JTAG debug and test functionality. JTAG is a standard five-wire protocol providing debug and test functionality. In addition, the two Serial Wire signals (SWDIO and SWCLK) are overlaid on two of the JTAG signals (JTMS and JTCK). This keeps the design compact and allows debug tools to switch between Serial Wire and JTAG as needed, without changing pin connections.

While Serial Wire and JTAG offer the same debug and test functionality, Silicon Labs recommends Serial Wire. Serial Wire uses only two pins instead of five, and offers a simple communication protocol, high performance data rates, low power, built-in error detection, and protection from glitches.

The ARM CoreSight™ Debug Access Port (DAP) comprises the Serial Wire and JTAG Interface (SWJ). As illustrated in Figure 15.1, the DAP includes two primary components: a debug port (the SWJ-DP) and an access port (the AHB-AP). The SWJ-DP provides external debug access while the AHB-AP provides internal bus access. An external debug tool connected to the EM341's debug pins communicates with the SWJ-DP. The SWJ-DP then communicates with the AHB-AP. Finally, the AHB-AP communicates on the internal bus.

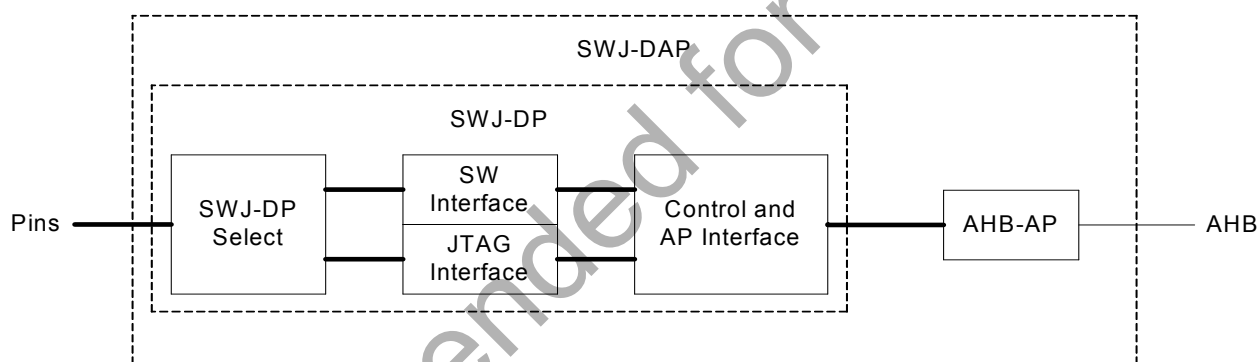

**Figure 15.1. SWJ Block Diagram**

Serial Wire and JTAG share five pins:

- JRST
- JTDO
- JTDI
- SWDIO/JTMS
- SWCLK/JTCK

**Note:** The SWJ pins are forced functions, and their corresponding GPIO\_PxCFGL configurations are overridden when the EM341 resets. An application must disable all debug SWJ debug functionality to reclaim any of the four SWJ GPIOs: PC0, PC2, PC3, and PC4.

Since these pins can be repurposed, refer to "17. Pin Definitions" on page 121 and "7.3. Forced Functions" on page 50 for complete pin descriptions and configurations.

For further information on the SWJ, contact customer support for application notes and ARM<sup>®</sup> CoreSight™ documentation.

# EM341

---

## 16. Ordering Information

Use the following part number to order the EM341:

Part Number	Part	Packaging Material	Configuration
EM341-RTR	EM341	2000 unit reel	Standard

The EM300 Series package is RoHS-compliant. It conforms to the European Court of Justice decision regarding the Deca-BDE exemption of the RoHS Directive. It is PFOS-compliant in accordance with European Directive 2006/122/EC\*1 released in December 2006. The EM341-RTR reel conforms to EIA Specification 481.

To order parts, contact Silicon Labs at 1+(877) 444-3032, or find a sales office or distributor on our website, [www.silabs.com](http://www.silabs.com).

Not Recommended for New Designs



## 17. Pin Definitions

### 17.1. Pin Definitions

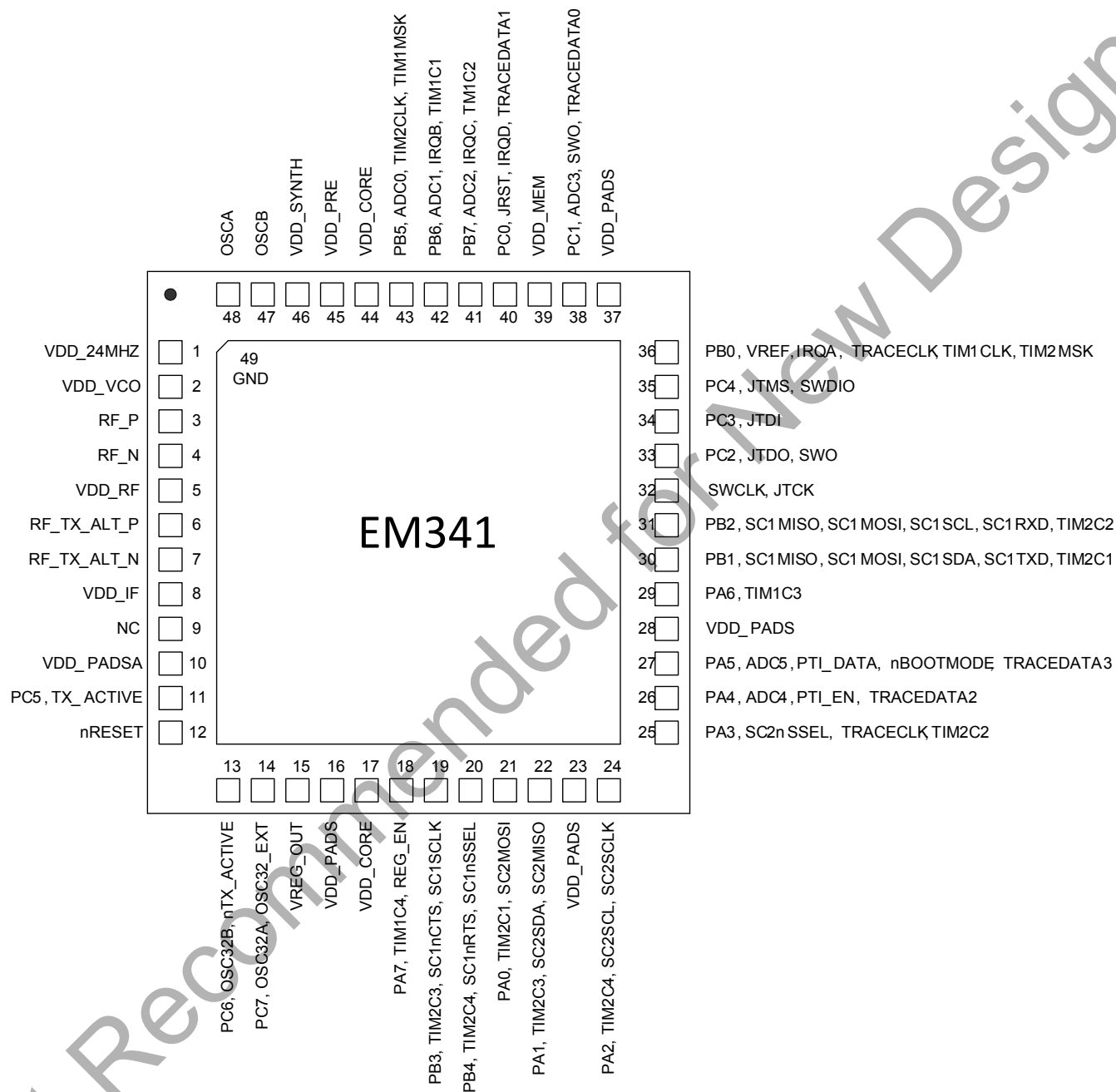

**Figure 17.1. EM341 Pin Definitions**

Refer to "7. GPIO (General Purpose Input/Output)" on page 48 for details about selecting GPIO pin functions.

Table 17.1. EM341 Pin Descriptions

Pin #	Signal	Direction	Description
1	VDD_24MHZ	Power	1.8 V high-frequency oscillator supply
2	VDD_VCO	Power	1.8 V VCO supply
3	RF_P	I/O	Differential (with RF_N) receiver input/transmitter output
4	RF_N	I/O	Differential (with RF_P) receiver input/transmitter output
5	VDD_RF	Power	1.8 V RF supply (LNA and PA)
6	RF_TX_ALT_P	O	Differential (with RF_TX_ALT_N) transmitter output (optional)
7	RF_TX_ALT_N	O	Differential (with RF_TX_ALT_P) transmitter output (optional)
8	VDD_IF	Power	1.8 V IF supply (mixers and filters)
9	NC		Do not connect
10	VDD_PADSA	Power	Analog pad supply (1.8 V)
11	PC5	I/O	Digital I/O
	TX_ACTIVE	O	Logic-level control for external RX/TX switch. The EM341 baseband controls TX_ACTIVE and drives it high (VDD_PADS) when in TX mode. Select alternate output function with GPIO_PCCFGH[7:4]
12	nRESET	I	Active low chip reset (internal pull-up)
13	PC6	I/O	Digital I/O
	OSC32B	I/O	32.768 kHz crystal oscillator Select analog function with GPIO_PCCFGH[11:8]
	nTX_ACTIVE	O	Inverted TX_ACTIVE signal (see PC5) Select alternate output function with GPIO_PCCFGH[11:8]
14	PC7	I/O	Digital I/O
	OSC32A	I/O	32.768 kHz crystal oscillator Select analog function with GPIO_PCCFGH[15:12]
	OSC32_EXT	I	Digital 32.768 kHz clock input source
15	VREG_OUT	Power	Regulator output (1.8 V while awake, 0 V during deep sleep)
16	VDD_PADS	Power	Pads supply (2.1–3.6 V)
17	VDD_CORE	Power	1.25 V digital core supply decoupling

Table 17.1. EM341 Pin Descriptions (Continued)

Pin #	Signal	Direction	Description
18	PA7	I/O High current	Digital I/O Disable REG_EN with GPIO_DBGCFG[4]
	TIM1C4	O	Timer 1 Channel 4 output Enable timer output with TIM1_CCER Select alternate output function with GPIO_PACFGH[15:12] Disable REG_EN with GPIO_DBGCFG[4]
	TIM1C4	I	Timer 1 Channel 4 input Cannot be remapped
	REG_EN	O	External regulator open drain output Enabled after reset
19	PB3	I/O	Digital I/O
	TIM2C3 (see also Pin 22)	O	Timer 2 channel 3 output Enable remap with TIM2_OR[6] Enable timer output in TIM2_CCER Select alternate output function with GPIO_PBCFGL[15:12]
	TIM2C3 (see also Pin 22)	I	Timer 2 channel 3 input Enable remap with TIM2_OR[6]
	SC1nCTS	I	UART CTS handshake of Serial Controller 1 Enable with SC1_UARTCFG[5] Select UART with SC1_MODE
	SC1SCLK	O	SPI master clock of Serial Controller 1 Either disable timer output in TIM2_CCER, or disable remap with TIM2_OR[6] Enable master with SC1_SPICFG[4] Select SPI with SC1_MODE Select alternate output function with GPIO_PBCFGL[15:12]
	SC1SCLK	I	SPI slave clock of Serial Controller 1 Enable slave with SC1_SPICFG[4] Select SPI with SC1_MODE

Table 17.1. EM341 Pin Descriptions (Continued)

Pin #	Signal	Direction	Description
20	PB4	I/O	Digital I/O
	TIM2C4 (see also Pin 24)	O	Timer 2 channel 4 output Enable remap with TIM2_OR[7] Enable timer output in TIM2_CCER Select alternate output function with GPIO_PBCFGH[3:0]
	TIM2C4 (see also Pin 24)	I	Timer 2 channel 4 input Enable remap with TIM2_OR[7]
	SC1nRTS	O	UART RTS handshake of Serial Controller 1 Either disable timer output in TIM2_CCER, or disable remap with TIM2_OR[7] Enable with SC1_UARTCFG[5] Select UART with SC1_MODE Select alternate output function with GPIO_PBCFGH[3:0]
	SC1nSSEL	I	SPI slave select of Serial Controller 1 Enable slave with SC1_SPICFG[4] Select SPI with SC1_MODE
21	PA0	I/O	Digital I/O
	TIM2C1 (see also Pin 30)	O	Timer 2 channel 1 output Disable remap with TIM2_OR[4] Enable timer output in TIM2_CCER Select alternate output function with GPIO_PACFGL[3:0]
	TIM2C1 (see also Pin 30)	I	Timer 2 channel 1 input Disable remap with TIM2_OR[4]
	SC2MOSI	O	SPI master data out of Serial Controller 2 Either disable timer output in TIM2_CCER, or enable remap with TIM2_OR[4] Enable master with SC2_SPICFG[4] Select SPI with SC2_MODE Select alternate output function with GPIO_PACFGL[3:0]
	SC2MOSI	I	SPI slave data in of Serial Controller 2 Enable slave with SC2_SPICFG[4] Select SPI with SC2_MODE

Table 17.1. EM341 Pin Descriptions (Continued)

Pin #	Signal	Direction	Description
22	PA1	I/O	Digital I/O
	TIM2C3 (see also Pin 19)	O	Timer 2 channel 3 output Disable remap with TIM2_OR[6] Enable timer output in TIM2_CCER Select alternate output function with GPIO_PACFGL[7:4]
	TIM2C3 (see also Pin 19)	I	Timer 2 channel 3 input Disable remap with TIM2_OR[6]
	SC2SDA	I/O	TWI data of Serial Controller 2 Either disable timer output in TIM2_CCER, or enable remap with TIM2_OR[6] Select TWI with SC2_MODE Select alternate open-drain output function with GPIO_PACFGL[7:4]
	SC2MISO	O	SPI slave data out of Serial Controller 2 Either disable timer output in TIM2_CCER, or enable remap with TIM2_OR[6] Enable slave with SC2_SPICFG[4] Select SPI with SC2_MODE Select alternate output function with GPIO_PACFGL[7:4]
	SC2MISO	I	SPI master data in of Serial Controller 2 Enable slave with SC2_SPICFG[4] Select SPI with SC2_MODE
23	VDD_PADS	Power	Pads supply (2.1–3.6 V)

Table 17.1. EM341 Pin Descriptions (Continued)

Pin #	Signal	Direction	Description
24	PA2	I/O	Digital I/O
	TIM2C4 (see also Pin 20)	O	Timer 2 channel 4 output Disable remap with TIM2_OR[7] Enable timer output in TIM2_CCER Select alternate output function with GPIO_PACFGL[11:8]
	TIM2C4 (see also Pin 20)	I	Timer 2 channel 4 input Disable remap with TIM2_OR[7]
	SC2SCL	I/O	TWI clock of Serial Controller 2 Either disable timer output in TIM2_CCER, or enable remap with TIM2_OR[7] Select TWI with SC2_MODE Select alternate open-drain output function with GPIO_PACFGL[11:8]
	SC2SCLK	O	SPI master clock of Serial Controller 2 Either disable timer output in TIM2_CCER, or enable remap with TIM2_OR[7] Enable master with SC2_SPICFG[4] Select SPI with SC2_MODE Select alternate output function with GPIO_PACFGL[11:8]
	SC2SCLK	I	SPI slave clock of Serial Controller 2 Enable slave with SC2_SPICFG[4] Select SPI with SC2_MODE
25	PA3	I/O	Digital I/O
	SC2nSSEL	I	SPI slave select of Serial Controller 2 Enable slave with SC2_SPICFG[4] Select SPI with SC2_MODE
	TRACECLK (see also Pin 36)	O	Synchronous CPU trace clock Either disable timer output in TIM2_CCER, or enable remap with TIM2_OR[5] Enable trace interface in ARM core Select alternate output function with GPIO_PACFGL[15:12]
	TIM2C2 (see also Pin 31)	O	Timer 2 channel 2 output Disable remap with TIM2_OR[5] Enable timer output in TIM2_CCER Select alternate output function with GPIO_PACFGL[15:12]
	TIM2C2 (see also Pin 31)	I	Timer 2 channel 2 input Disable remap with TIM2_OR[5]

Table 17.1. EM341 Pin Descriptions (Continued)

Pin #	Signal	Direction	Description
26	PA4	I/O	Digital I/O
	ADC4	Analog	ADC Input 4 Select analog function with GPIO_PACFGH[3:0]
	PTI_EN	O	Frame signal of Packet Trace Interface (PTI) Disable trace interface in ARM core Enable PTI in Ember software Select alternate output function with GPIO_PACFGH[3:0]
	TRACEDATA2	O	Synchronous CPU trace data bit 2 Select 4-wire synchronous trace interface in ARM core Enable trace interface in ARM core Select alternate output function with GPIO_PACFGH[3:0]
27	PA5	I/O	Digital I/O
	ADC5	Analog	ADC Input 5 Select analog function with GPIO_PACFGH[7:4]
	PTI_DATA	O	Data signal of Packet Trace Interface (PTI) Disable trace interface in ARM core Enable PTI in Ember software Select alternate output function with GPIO_PACFGH[7:4]
	nBOOTMODE	I	Activate FIB monitor instead of main program or bootloader when coming out of reset. Signal is active during and immediately after a reset on nRESET. See "7.5. Boot Configuration" on page 51.
	TRACEDATA3	O	Synchronous CPU trace data bit 3 Select 4-wire synchronous trace interface in ARM core Enable trace interface in ARM core Select alternate output function with GPIO_PACFGH[7:4]
28	VDD_PADS	Power	Pads supply (2.1–3.6 V)
29	PA6	I/O High current	Digital I/O
	TIM1C3	O	Timer 1 channel 3 output Enable timer output in TIM1_CCER Select alternate output function with GPIO_PACFGH[11:8]
	TIM1C3	I	Timer 1 channel 3 input Cannot be remapped

Table 17.1. EM341 Pin Descriptions (Continued)

Pin #	Signal	Direction	Description
30	PB1	I/O	Digital I/O
	SC1MISO	O	SPI slave data out of Serial Controller 1 Either disable timer output in TIM2_CCER, or disable remap with TIM2_OR[4] Select SPI with SC1_MODE Select slave with SC1_SPICR Select alternate output function with GPIO_PBCFGL[7:4]
	SC1MOSI	O	SPI master data out of Serial Controller 1 Either disable timer output in TIM2_CCER, or disable remap with TIM2_OR[4] Select SPI with SC1_MODE Select master with SC1_SPICR Select alternate output function with GPIO_PBCFGL[7:4]
	SC1SDA	I/O	TWI data of Serial Controller 1 Either disable timer output in TIM2_CCER, or disable remap with TIM2_OR[4] Select TWI with SC1_MODE Select alternate open-drain output function with GPIO_PBCFGL[7:4]
	SC1TXD	O	UART transmit data of Serial Controller 1 Either disable timer output in TIM2_CCER, or disable remap with TIM2_OR[4] Select UART with SC1_MODE Select alternate output function with GPIO_PBCFGL[7:4]
	TIM2C1 (see also Pin 21)	O	Timer 2 channel 1 output Enable remap with TIM2_OR[4] Enable timer output in TIM2_CCER Select alternate output function with GPIO_PACFGL[7:4]
	TIM2C1 (see also Pin 21)	I	Timer 2 channel 1 input Disable remap with TIM2_OR[4]



Table 17.1. EM341 Pin Descriptions (Continued)

Pin #	Signal	Direction	Description
31	PB2	I/O	Digital I/O
	SC1MISO	I	SPI master data in of Serial Controller 1 Select SPI with SC1_MODE Select master with SC1_SPICR
	SC1MOSI	I	SPI slave data in of Serial Controller 1 Select SPI with SC1_MODE Select slave with SC1_SPICR
	SC1SCL	I/O	TWI clock of Serial Controller 1 Either disable timer output in TIM2_CCER, or disable remap with TIM2_OR[5] Select TWI with SC1_MODE Select alternate open-drain output function with GPIO_PBCFGL[11:8]
	SC1RXD	I	UART receive data of Serial Controller 1 Select UART with SC1_MODE
	TIM2C2 (see also Pin 25)	O	Timer 2 channel 2 output Enable remap with TIM2_OR[5] Enable timer output in TIM2_CCER Select alternate output function with GPIO_PBCFGL[11:8]
	TIM2C2 (see also Pin 25)	I	Timer 2 channel 2 input Enable remap with TIM2_OR[5]
32	SWCLK	I/O	Serial Wire clock input/output with debugger Selected when in Serial Wire mode (see JTMS description, Pin 35)
	JTCK	I	JTAG clock input from debugger Selected when in JTAG mode (default mode, see JTMS description, Pin 35) Internal pull-down is enabled
33	PC2	I/O	Digital I/O Enable with GPIO_DBGCFG[5]
	JTDO	O	JTAG data out to debugger Selected when in JTAG mode (default mode, see JTMS description, Pin 35)
	SWO	O	Serial Wire Output asynchronous trace output to debugger Select asynchronous trace interface in ARM core Enable trace interface in ARM core Select alternate output function with GPIO_PCCFGL[11:8] Enable Serial Wire mode (see JTMS description, Pin 35) Internal pull-up is enabled

Table 17.1. EM341 Pin Descriptions (Continued)

Pin #	Signal	Direction	Description
34	PC3	I/O	Digital I/O Either Enable with GPIO_DBGCFG[5], or enable Serial Wire mode (see JTMS description)
	JTDI	I	JTAG data in from debugger Selected when in JTAG mode (default mode, see JTMS description, Pin 35) Internal pull-up is enabled
35	PC4	I/O	Digital I/O Enable with GPIO_DBGCFG[5]
	JTMS	I	JTAG mode select from debugger Selected when in JTAG mode (default mode) JTAG mode is enabled after power-up or by forcing nRESET low Select Serial Wire mode using the ARM-defined protocol through a debugger Internal pull-up is enabled
	SWDIO	I/O	Serial Wire bidirectional data to/from debugger Enable Serial Wire mode (see JTMS description) Select Serial Wire mode using the ARM-defined protocol through a debugger Internal pull-up is enabled
36	PB0	I/O	Digital I/O
	VREF	Analog O	ADC reference output Enable analog function with GPIO_PBCFGL[3:0]
	IRQA	I	External interrupt source A
	TRACECLK (see also Pin 25)	O	Synchronous CPU trace clock Enable trace interface in ARM core Select alternate output function with GPIO_PBCFGL[3:0]
	TIM1CLK	I	Timer 1 external clock input
	TIM2MSK	I	Timer 2 external clock mask input
37	VDD_PADS	Power	Pads supply (2.1–3.6 V)

Table 17.1. EM341 Pin Descriptions (Continued)

Pin #	Signal	Direction	Description
38	PC1	I/O	Digital I/O
	ADC3	Analog	ADC Input 3 Enable analog function with GPIO_PCCFGL[7:4]
	SWO (see also Pin 33)	O	Serial Wire Output asynchronous trace output to debugger Select asynchronous trace interface in ARM core Enable trace interface in ARM core Select alternate output function with GPIO_PCCFGL[7:4]
	TRACEDATA0	O	Synchronous CPU trace data bit 0 Select 1-, 2- or 4-wire synchronous trace interface in ARM core Enable trace interface in ARM core Select alternate output function with GPIO_PCCFGL[7:4]
39	VDD_MEM	Power	1.8 V supply (flash, RAM)
40	PC0	I/O High current	Digital I/O Either enable with GPIO_DBGCFG[5], or enable Serial Wire mode (see JTMS description, Pin 35) and disable TRACEDATA1
	JRST	I	JTAG reset input from debugger Selected when in JTAG mode (default mode, see JTMS description) and TRACEDATA1 is disabled Internal pull-up is enabled
	IRQD	I	Default external interrupt source D. IRQC and IRQD external interrupts can be mapped to any digital I/O pin using the GPIO_IRQSEL and GPIO_IRQDSEL registers.
	TRACEDATA1	O	Synchronous CPU trace data bit 1 Select 2- or 4-wire synchronous trace interface in ARM core Enable trace interface in ARM core Select alternate output function with GPIO_PCCFGL[3:0]
41	PB7	I/O High current	Digital I/O
	ADC2	Analog	ADC Input 2 Enable analog function with GPIO_PBCFGH[15:12]
	IRQC	I	Default external interrupt source C. IRQC and IRQD external interrupts can be mapped to any digital I/O pin using the GPIO_IRQSEL and GPIO_IRQDSEL registers.
	TIM1C2	O	Timer 1 channel 2 output Enable timer output in TIM1_CCER Select alternate output function with GPIO_PBCFGH[15:12]
	TIM1C2	I	Timer 1 channel 2 input Cannot be remapped

Table 17.1. EM341 Pin Descriptions (Continued)

Pin #	Signal	Direction	Description
42	PB6	I/O High current	Digital I/O
	ADC1	Analog	ADC Input 1 Enable analog function with GPIO_PBCFGH[11:8]
	IRQB	I	External interrupt source B
	TIM1C1	O	Timer 1 channel 1 output Enable timer output in TIM1_CCER Select alternate output function with GPIO_PBCFGH[11:8]
	TIM1C1	I	Timer 1 channel 1 input Cannot be remapped
43	PB5	I/O	Digital I/O
	ADC0	Analog	ADC Input 0 Enable analog function with GPIO_PBCFGH[7:4]
	TIM2CLK	I	Timer 2 external clock input
	TIM1MSK	I	Timer 1 external clock mask input
44	VDD_CORE	Power	1.25 V digital core supply decoupling
45	VDD_PRE	Power	1.8 V prescaler supply
46	VDD_SYNT	Power	1.8 V synthesizer supply
47	OSCB	I/O	24 MHz crystal oscillator or left open when using external clock input on OSCA
48	OSCA	I/O	24 MHz crystal oscillator or external clock input. (An external clock input should only be used for test and debug purposes. If used in this manner, the external clock input should be a 1.8 V, 50% duty cycle, square wave.)
49	GND	Ground	Ground supply pad in the bottom center of the package forms Pin 49. See the various Ember <i>EM35x Reference Design</i> documentation for PCB considerations.

# EM341

## 18. Package

The EM341 package is a plastic 48-pin QFN that is 7 mm x 7 mm. Figure 18.1 illustrates the package drawing.

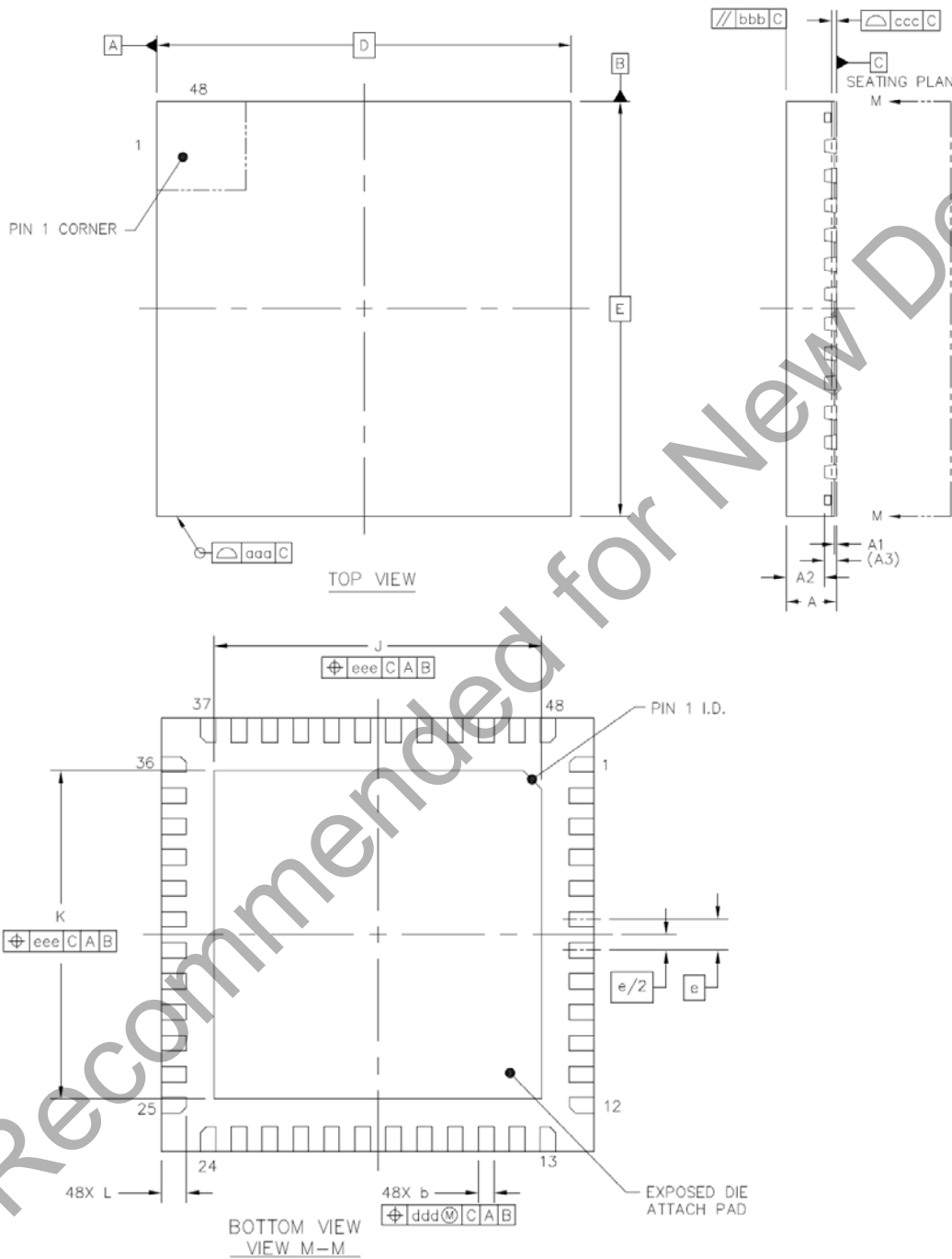
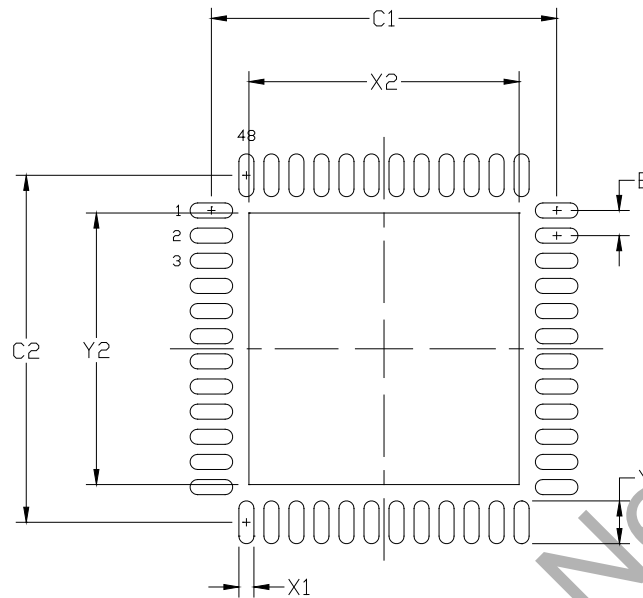

Figure 18.1. Package Drawing

Table 18.1. Package Dimensions

Dimension	MIN	NOM	MAX
A	0.80	0.85	0.90
A1	0	0.035	0.05
A2	—	0.65	0.67
A3	0.203 REF		
b	0.2	0.25	0.3
D	7 BSC		
E	7 BSC		
e	0.5 BSC		
J	5.2	5.3	5.4
K	5.2	5.3	5.4
L	0.35	0.40	0.45
aaa	0.10		
bbb	0.1		
ccc	0.08		
ddd	0.1		
eee	0.1		
<b>Notes:</b>			
<ol style="list-style-type: none"> <li>1. All dimensions shown are in millimeters (mm) unless otherwise noted.</li> <li>2. Dimensioning and Tolerancing per ANSI Y14.5M-1994.</li> <li>3. This drawing conforms to the JEDEC Solid State Outline MO-220, Variation VKKD-4.</li> <li>4. Recommended card reflow profile is per the JEDEC/IPC J-STD-020 specification for Small Body Components.</li> </ol>			



**Figure 18.2. Solder Mask Dimensions**

**Table 18.2. PCB Land Pattern**

Dimension	Min	Max
C1	6.80	6.90
C2	6.80	6.90
E	0.50 BSC	
X1	0.20	0.30
X2	5.20	5.40
Y1	0.75	0.85
Y2	5.20	5.40

**Notes:**

**General**

1. All dimensions shown are in millimeters (mm) unless otherwise noted.
2. This Land Pattern Design is based on the IPC-7351 guidelines.

**Solder Mask Design**

1. All metal pads are to be non-solder mask defined (NSMD). Clearance between the solder mask and the metal pad is to be 60µm minimum, all the way around the pad.

**Stencil Design**

1. A stainless steel, laser-cut and electro-polished stencil with trapezoidal walls should be used to assure good solder paste release.
2. The stencil thickness should be 0.125 mm (5 mils).
3. The ratio of stencil aperture to land pad size should be 1:1 for all perimeter pads.
4. A 4x4 array of 1.1 mm square openings on 1.3 mm pitch can be used for the center ground pad.

**Card Assembly**

1. A No-Clean, Type-3 solder paste is recommended.
2. The recommended card reflow profile is per the JEDEC/IPC J-STD-020C specification for Small Body Components.

## 19. Top Marking

Figure 19.1 shows the part marking for the EM341 Series. The circle in the top corner indicates Pin 1. Pins are numbered counter-clockwise from Pin 1 with 12 pins per package edge.



Figure 19.1. Part Marking for EM341

Table 19.1. 48-Pin QFN Top Marking Explanation

<b>Mark Method:</b>	Laser	
<b>Pin 1 Marking:</b>	Circle = 0.40 mm Diameter (Top-Left Justified)	
<b>Line 1 Marking:</b>	Logo and Device Part Number Right Justified	Silicon Labs logo and EM341.
<b>Line 2 Marking:</b>	TTTTTT = Mfg Code YY=Year WW-Work Week	Manufacturing Code from the Assembly Purchase form. Assigned by the Assembly House. Corresponds to the year and work week. Right Justified
<b>Line 3 Marking:</b>	Circle = 1.3 mm Diameter Center Justified  Country of Origin ISO abbreviation Right Justified	"e3" indicates Sn solder finish.  TW



## APPENDIX A—REGISTER ADDRESS TABLE

BLOCK	CM_LV	40004000–40004038 CM_LV		
Address	Name	Type	Reset	Description
40004038	PERIPHERAL_DISABLE	RW	0	Peripheral Disable Register

BLOCK	INTERRUPTS	4000A000–4000AFFF Interrupts		
Address	Name	Type	Reset	Description
4000A800	INT_TIM1FLAG	RW	0	Timer 1 Interrupt Flag Register
4000A804	INT_TIM2FLAG	RW	0	Timer 2 Interrupt Flag Register
4000A808	INT_SC1FLAG	RW	0	Serial Controller 1 Interrupt Flag Register
4000A80C	INT_SC2FLAG	RW	0	Serial Controller 2 Interrupt Flag Register
4000A810	INT_ADCFLAG	RW	0	ADC Interrupt Flag Register
4000A814	INT_GPIOFLAG	RW	0	GPIO Interrupt Flag Register
4000A818	INT_TIM1MISS	RW	0	Timer 1 Missed Interrupt Register
4000A81C	INT_TIM2MISS	RW	0	Timer 2 Missed Interrupts Register
4000A820	INT_MISS	RW	0	Top-Level Missed Interrupts Register
4000A840	INT_TIM1CFG	RW	0	Timer 1 Interrupt Configuration Register
4000A844	INT_TIM2CFG	RW	0	Timer 2 Interrupt Configuration Register
4000A848	INT_SC1CFG	RW	0	Serial Controller 1 Interrupt Configuration Register
4000A84C	INT_SC2CFG	RW	0	Serial Controller 2 Interrupt Configuration Register
4000A850	INT_ADCCFG	RW	0	ADC Interrupt Configuration Register
4000A854	SC1_INTMODE	RW	0	Serial Controller 1 Interrupt Mode Register
4000A858	SC2_INTMODE	RW	0	Serial Controller 2 Interrupt Mode Register
4000A860	GPIO_INTCFGA	RW	0	GPIO Interrupt A Configuration Register
4000A864	GPIO_INTCFGB	RW	0	GPIO Interrupt B Configuration Register
4000A868	GPIO_INTCFGC	RW	0	GPIO Interrupt C Configuration Register
4000A86C	GPIO_INTCFGD	RW	0	GPIO Interrupt D Configuration Register

BLOCK	GPIO		4000B000–4000BFFF General Purpose IO	
Address	Name	Type	Reset	Description
4000B000	GPIO_PACFGL	RW	4444	Port A Configuration Register (Low)
4000B004	GPIO_PACFGH	RW	4444	Port A Configuration Register (High)
4000B008	GPIO_PAIN	RW	0	Port A Input Data Register
4000B00C	GPIO_PAOUT	RW	0	Port A Output Data Register
4000B010	GPIO_PASET	RW	0	Port A Output Set Register
4000B014	GPIO_PACLR	RW	0	Port A Output Clear Register
4000B400	GPIO_PBCFGL	RW	4444	Port B Configuration Register (Low)
4000B404	GPIO_PBCFGH	RW	4444	Port B Configuration Register (High)
4000B408	GPIO_PBIN	RW	0	Port B Input Data Register
4000B40C	GPIO_PBOUT	RW	0	Port B Output Data Register
4000B410	GPIO_PBSET	RW	0	Port B Output Set Register
4000B414	GPIO_PBCLR	RW	0	Port B Output Clear Register
4000B800	GPIO_PCCFGL	RW	4444	Port C Configuration Register (Low)
4000B804	GPIO_PCCFGH	RW	4444	Port C Configuration Register (High)
4000B808	GPIO_PCIN	RW	0	Port C Input Data Register
4000B80C	GPIO_PCOUT	RW	0	Port C Output Data Register
4000B810	GPIO_PCSET	RW	0	Port C Output Set Register
4000B814	GPIO_PCCLR	RW	0	Port C Output Clear Register
4000BC00	GPIO_DBGCFG	RW	10	GPIO Debug Configuration Register
4000BC04	GPIO_DBGSTAT	R	0	GPIO Debug Status Register
4000BC08	GPIO_PAWAKE	RW	0	Port A Wakeup Monitor Register
4000BC0C	GPIO_PBWAKE	RW	0	Port B Wakeup Monitor Register
4000BC10	GPIO_PCWAKE	RW	0	Port C Wakeup Monitor Register
4000BC14	GPIO_IRQCSEL	RW	F	Interrupt C Select Register
4000BC18	GPIO_IRQDSEL	RW	10	Interrupt D Select Register
4000BC1C	GPIO_WAKEFILT	RW	0	GPIO Wakeup Filtering Register

# EM341

BLOCK	SERIAL	4000C000–4000CFFF Serial Controllers		
Address	Name	Type	Reset	Description
4000C000	SC2_RXBEGA	RW	20000000	Receive DMA Begin Address Register A
4000C004	SC2_RXENDA	RW	20000000	Receive DMA End Address Register A
4000C008	SC2_RXBEGB	RW	20000000	Receive DMA Begin Address Register B
4000C00C	SC2_RXENDB	RW	20000000	Receive DMA End Address Register B
4000C010	SC2_TXBEGA	RW	20000000	Transmit DMA Begin Address Register A
4000C014	SC2_TXENDA	RW	20000000	Transmit DMA End Address Register A
4000C018	SC2_TXBEGB	RW	20000000	Transmit DMA Begin Address Register B
4000C01C	SC2_TXENDB	RW	20000000	Transmit DMA End Address Register B
4000C020	SC2_RXCNTA	R	0	Receive DMA Count Register A
4000C024	SC2_RXCNTB	R	0	Receive DMA Count Register B
4000C028	SC2_TXCNT	R	0	Transmit DMA Count Register
4000C02C	SC2_DMASTAT	R	0	Serial DMA Status Register
4000C030	SC2_DMACTRL	RW	0	Serial DMA Control Register
4000C034	SC2_RXERRA	R	0	DMA First Receive Error Register A
4000C038	SC2_RXERRB	R	0	DMA First Receive Error Register B
4000C03C	SC2_DATA	RW	0	Serial Data Register
4000C040	SC2_SPISTAT	R	0	SPI Status Register
4000C044	SC2_TWISTAT	R	0	TWI Status Register
4000C04C	SC2_TWICTRL1	RW	0	TWI Control Register 1
4000C050	SC2_TWICTRL2	RW	0	TWI Control Register 2
4000C054	SC2_MODE	RW	0	Serial Mode Register
4000C058	SC2_SPICFG	RW	0	SPI Configuration Register
4000C060	SC2_RATELIN	RW	0	Serial Clock Linear Prescaler Register
4000C064	SC2_RATEEXP	RW	0	Serial Clock Exponential Prescaler Register
4000C070	SC2_RXCNTSAVED	R	0	Saved Receive DMA Count Register
4000C800	SC1_RXBEGA	RW	20000000	Receive DMA Begin Address Register A
4000C804	SC1_RXENDA	RW	20000000	Receive DMA End Address Register A
4000C808	SC1_RXBEGB	RW	20000000	Receive DMA Begin Address Register B

BLOCK	SERIAL	4000C000–4000CFFF Serial Controllers		
Address	Name	Type	Reset	Description
4000C80C	SC1_RXENDB	RW	20000000	Receive DMA End Address Register B
4000C810	SC1_TXBEGA	RW	20000000	Transmit DMA Begin Address Register A
4000C814	SC1_TXENDA	RW	20000000	Transmit DMA End Address Register A
4000C818	SC1_TXBEGB	RW	20000000	Transmit DMA Begin Address Register B
4000C81C	SC1_TXENDB	RW	20000000	Transmit DMA End Address Register B
4000C820	SC1_RXCNTA	R	0	Receive DMA Count Register A
4000C824	SC1_RXCNTB	R	0	Receive DMA Count Register B
4000C828	SC1_TXCNT	R	0	Transmit DMA Count Register
4000C82C	SC1_DMASTAT	R	0	Serial DMA Status Register
4000C830	SC1_DMACTRL	RW	0	Serial DMA Control Register
4000C834	SC1_RXERRA	R	0	DMA First Receive Error Register A
4000C838	SC1_RXERRB	R	0	DMA First Receive Error Register B
4000C83C	SC1_DATA	RW	0	Serial Data Register
4000C840	SC1_SPISTAT	R	0	SPI Status Register
4000C844	SC1_TWISTAT	R	0	TWI Status Register
4000C848	SC1_UARTSTAT	R	40	UART Status Register
4000C84C	SC1_TWICTRL1	RW	0	TWI Control Register 1
4000C850	SC1_TWICTRL2	RW	0	TWI Control Register 2
4000C854	SC1_MODE	RW	0	Serial Mode Register
4000C858	SC1_SPICFG	RW	0	SPI Configuration Register
4000C85C	SC1_UARTCFG	RW	0	UART Configuration Register
4000C860	SC1_RATELIN	RW	0	Serial Clock Linear Prescaler Register
4000C864	SC1_RATEEXP	RW	0	Serial Clock Exponential Prescaler Register
4000C868	SC1_UARTPER	RW	0	UART Baud Rate Period Register
4000C86C	SC1_UARTFRAC	RW	0	UART Baud Rate Fractional Period Register
4000C870	SC1_RXCNTSAVED	R	0	Saved Receive DMA Count Register

# EM341

BLOCK	ADC	4000D000 - 4000DFFF Analog to Digital Converter		
Address	Name	Type	Reset	Description
4000D000	ADC_DATA	R	0	ADC Data Register
4000D004	ADC_CFG	RW	00001800	ADC Configuration Register
4000D008	ADC_OFFSET	RW	0000	ADC Offset Register
4000D00C	ADC_GAIN	RW	8000	ADC Gain Register
4000D010	ADC_DMACFG	RW	0	ADC DMA Configuration Register
4000D014	ADC_DMASTAT	R	0	ADC DMA Status Register
4000D018	ADC_DMABEG	RW	20000000	ADC DMA Begin Address Register
4000D01C	ADC_DMASIZE	RW	0	ADC DMA Buffer Size Register
4000D020	ADC_DMACUR	R	20000000	ADC DMA Current Address Register
4000D024	ADC_DMACNT	R	0	ADC DMA Count Register

BLOCK	TIM1	4000E000 - 4000EFFF General Purpose Timer 1		
Address	Name	Type	Reset	Description
4000E000	TIM1_CR1	RW	0	Timer 1 Control Register 1
4000E004	TIM1_CR2	RW	0	Timer 1 Control Register 2
4000E008	TIM1_SMCR	RW	0	Timer 1 Slave Mode Control Register
4000E014	TIM1_EGR	RW	0	Timer 1 Event Generation Register
4000E018	TIM1_CCMR1	RW	0	Timer 1 Capture/Compare Mode Register 1
4000E01C	TIM1_CCMR2	RW	0	Timer 1 Capture/Compare Mode Register 2
4000E020	TIM1_CCER	RW	0	Timer 1 Capture/Compare Enable Register
4000E024	TIM1_CNT	RW	0	Timer 1 Counter Register
4000E028	TIM1_PSC	RW	0	Timer 1 Prescaler Register
4000E02C	TIM1_ARR	RW	FFFF	Timer 1 Auto-Reload Register
4000E034	TIM1_CCR1	RW	0	Timer 1 Capture/Compare Register 1
4000E038	TIM1_CCR2	RW	0	Timer 1 Capture/Compare Register 2
4000E03C	TIM1_CCR3	RW	0	Timer 1 Capture/Compare Register 3
4000E040	TIM1_CCR4	RW	0	Timer 1 Capture/Compare Register 4
4000E050	TIM1_OR	RW	0	Timer 1 Option Register

BLOCK	TIM2	4000F000 - 4000FFFF General Purpose Timer 2		
Address	Name	Type	Reset	Description
4000F000	TIM2_CR1	RW	0	Timer 2 Control Register 1
4000F004	TIM2_CR2	RW	0	Timer 2 Control Register 2
4000F008	TIM2_SMCR	RW	0	Timer 2 Slave Mode Control Register
4000F014	TIM2_EGR	RW	0	Timer 2 Event Generation Register
4000F018	TIM2_CCMR1	RW	0	Timer 2 Capture/Compare Mode Register 1
4000F01C	TIM2_CCMR2	RW	0	Timer 2 Capture/Compare Mode Register 2
4000F020	TIM2_CCER	RW	0	Timer 2 Capture/Compare Enable Register
4000F024	TIM2_CNT	RW	0	Timer 2 Counter Register
4000F028	TIM2_PSC	RW	0	Timer 2 Prescaler Register
4000F02C	TIM2_ARR	RW	FFFF	Timer 2 Auto-Reload Register
4000F034	TIM2_CCR1	RW	0	Timer 2 Capture/Compare Register 1
4000F038	TIM2_CCR2	RW	0	Timer 2 Capture/Compare Register 2
4000F03C	TIM2_CCR3	RW	0	Timer 2 Capture/Compare Register 3
4000F040	TIM2_CCR4	RW	0	Timer 2 Capture/Compare Register 4
4000F050	TIM2_OR	RW	0	Timer 2 Option Register

BLOCK	NVIC	E000E000 - E000EFFF Nested Vectored Interrupt Controller		
Address	Name	Type	Reset	Description
E000E100	INT_CFGSET	RW	0	Top-Level Set Interrupts Configuration Register
E000E180	INT_CFGCLR	RW	0	Top-Level Clear Interrupts Configuration Register
E000E200	INT_PENDSET	RW	0	Top-Level Set Interrupts Pending Register
E000E280	INT_PENDCLR	RW	0	Top-Level Clear Interrupts Pending Register
E000E300	INT_ACTIVE	R	0	Top-Level Active Interrupts Register
E000ED3C	SCS_AFSR	RW	0	Auxiliary Fault Status Register

## APPENDIX B—ABBREVIATIONS AND ACRONYMS

Acronym/Abbreviation	Meaning
ACK	Acknowledgment
ADC	Analog to Digital Converter
AES	Advanced Encryption Standard
AGC	Automatic Gain Control
AHB	Advanced High Speed Bus
APB	Advanced Peripheral Bus
CBC-MAC	Cipher Block Chaining—Message Authentication Code
CCA	Clear Channel Assessment
CCM	Counter with CBC-MAC Mode for AES encryption
CCM*	Improved Counter with CBC-MAC Mode for AES encryption
CIB	Customer Information Block
CLK1K	1 kHz Clock
CLK32K	32.768 kHz Crystal Clock
CPU	Central Processing Unit
CRC	Cyclic Redundancy Check
CSMA-CA	Carrier Sense Multiple Access-Collision Avoidance
CTR	Counter Mode
CTS	Clear to Send
DNL	Differential Non-Linearity
DMA	Direct Memory Access
DWT	Data Watchpoint and Trace
EEPROM	Electrically Erasable Programmable Read Only Memory
EM	Event Manager
ENOB	effective number of bits
ESD	Electro Static Discharge
ESR	Equivalent Series Resistance
ETR	External Trigger Input
FCLK	ARM® Cortex™-M3 CPU Clock

Acronym/Abbreviation	Meaning
FIB	Fixed Information Block
FIFO	First-in, First-out
FPB	Flash Patch and Breakpoint
GPIO	General Purpose I/O (pins)
HF	High Frequency
I <sup>2</sup> C	Inter-Integrated Circuit
IDE	Integrated Development Environment
IF	Intermediate Frequency
IEEE	Institute of Electrical and Electronics Engineers
INL	Integral Non-linearity
ITM	Instrumentation Trace Macrocell
JTAG	Joint Test Action Group
LF	Low Frequency
LNA	Low Noise Amplifier
LQI	Link Quality Indicator
LSB	Least significant bit
MAC	Medium Access Control
MFB	Main Flash Block
MISO	Master in, slave out
MOS	Metal Oxide Semiconductor (P-channel or N-channel)
MOSI	Master out, slave in
MPU	Memory Protection Unit
MSB	Most significant bit
MSL	Moisture Sensitivity Level
NACK	Negative Acknowledge
NIST	National Institute of Standards and Technology
NMI	Non-Maskable Interrupt
NVIC	Nested Vectored Interrupt Controller
OPM	One-Pulse Mode



Acronym/Abbreviation	Meaning
O-QPSK	Offset-Quadrature Phase Shift Keying
OSC24M	High Frequency Crystal Oscillator
OSC32K	Low-Frequency 32.768 kHz Oscillator
OSCHF	High-Frequency Internal RC Oscillator
OSCRC	Low-Frequency RC Oscillator
PA	Power Amplifier
PCLK	Peripheral clock
PER	Packet Error Rate
PHY	Physical Layer
PLL	Phase-Locked Loop
POR	Power-On-Reset
PRNG	Pseudo Random Number Generator
PSD	Power Spectral Density
PTI	Packet Trace Interface
PWM	Pulse Width Modulation
QFN	Quad Flat Pack
RAM	Random Access Memory
RC	Resistive/Capacitive
RF	Radio Frequency
RMS	Root Mean Square
RoHS	Restriction of Hazardous Substances
RSSI	Receive Signal Strength Indicator
RTS	Request to Send
Rx	Receive
SYSCLK	System clock
SDFR	Spurious Free Dynamic Range
SFD	Start Frame Delimiter
SINAD	Signal-to-noise and distortion ratio
SPI	Serial Peripheral Interface

Acronym/Abbreviation	Meaning
SWJ	Serial Wire and JTAG Interface
THD	Total Harmonic Distortion
TRNG	True random number generator
TWI	Two Wire serial interface
Tx	Transmit
UART	Universal Asynchronous Receiver/Transmitter
UEV	Update event
VCO	Voltage Controlled Oscillator

Abbreviation	Meaning
dB	decibel
dBc	decibels relative to the carrier
dBm	decibels relative to 1 mW
GHz	GigaHerz
kB	Kilobyte
kbps	kilobits/second
kHz	kiloherz
k $\Omega$	kiloOhm
kV	kiloVolt
mA	milliAmpere
Mbps	Megabits per second
MHz	megaherz
M $\Omega$	megaOhm
MSPS	Megasamples per second
$\mu$ A	microAmpere
$\mu$ sec	microsecond
nH	nanohenry
ns	nanoseconds
$\Omega$	Ohm
pF	picofarad
ppm	part per million
V	Volt

## APPENDIX C—REFERENCES

- ZigBee Specification ([www.zigbee.org](http://www.zigbee.org); ZigBee Document 053474)
- ZigBee-PRO Stack Profile ([www.zigbee.org](http://www.zigbee.org); ZigBee Document 074855)
- ZigBee RF4CE: ZRC Profile Specification v 1.2 ([www.zigbee.org](http://www.zigbee.org); ZigBee Document 0368-16)
- ZigBee Stack Profile ([www.zigbee.org](http://www.zigbee.org); ZigBee Document 064321)
- Bluetooth Core Specification v2.1  
([http://www.bluetooth.org/docman/handlers/downloaddoc.ashx?doc\\_id=241363](http://www.bluetooth.org/docman/handlers/downloaddoc.ashx?doc_id=241363))
- IEEE 802.15.4-2003 (<http://standards.ieee.org/getieee802/download/802.15.4-2003.pdf>)
- IEEE 802.11g ([standards.ieee.org/getieee802/download/802.11g-2003.pdf](http://standards.ieee.org/getieee802/download/802.11g-2003.pdf))
- ARM<sup>®</sup> Cortex<sup>™</sup>-M3 reference manual (<http://infocenter.arm.com/help/topic/com.arm.doc.subset.cortexm.m3/index.html#cortexm3>)

Not Recommended for New Designs

## DOCUMENT CHANGE LIST

Revision 0.1 to 1.0

- Production Release

Not Recommended for New Designs

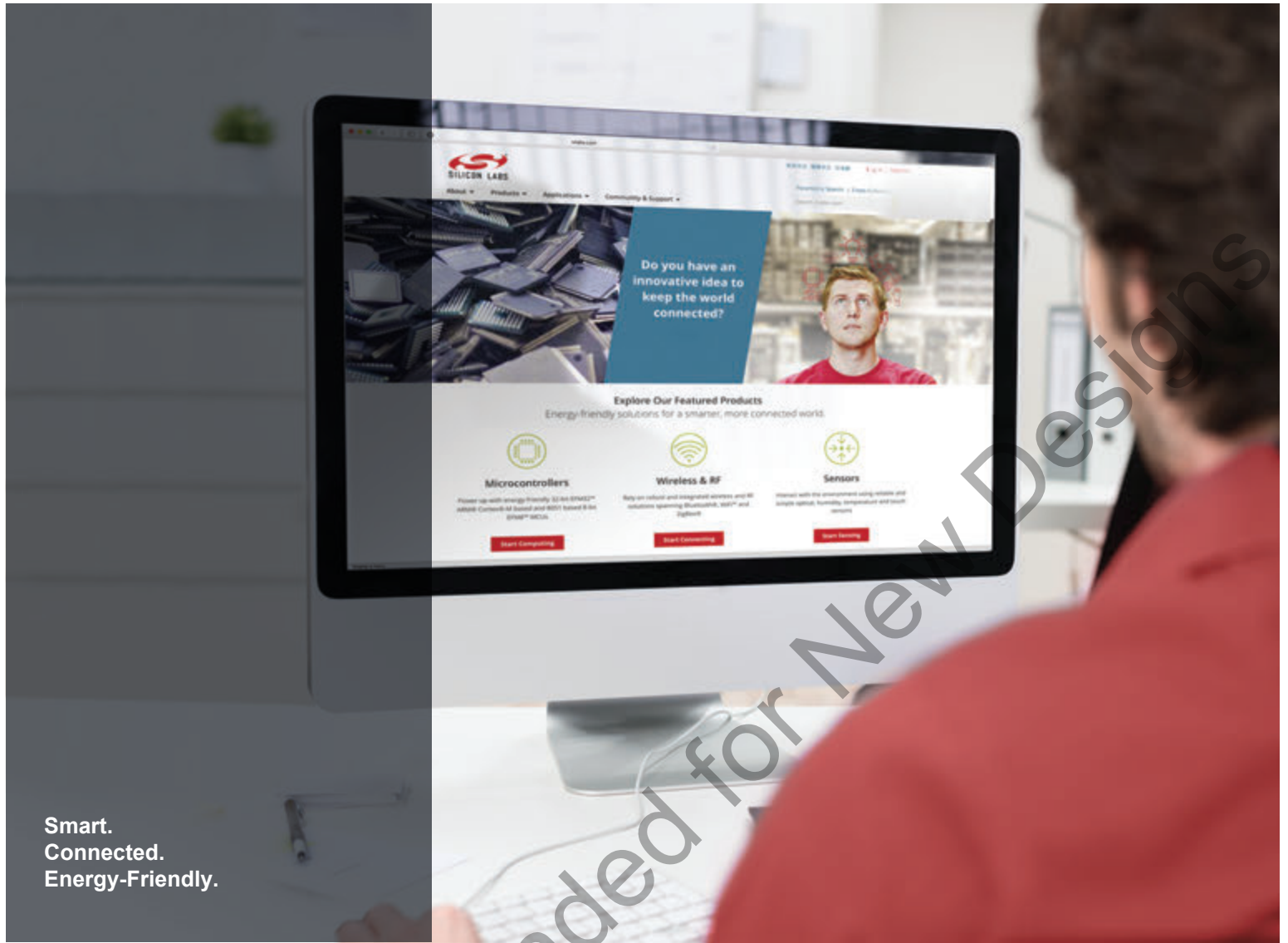

Smart.  
Connected.  
Energy-Friendly.



**Products**  
[www.silabs.com/products](http://www.silabs.com/products)

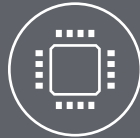

**Quality**  
[www.silabs.com/quality](http://www.silabs.com/quality)



**Support and Community**  
[community.silabs.com](http://community.silabs.com)

**Disclaimer**

Silicon Labs intends to provide customers with the latest, accurate, and in-depth documentation of all peripherals and modules available for system and software implementers using or intending to use the Silicon Labs products. Characterization data, available modules and peripherals, memory sizes and memory addresses refer to each specific device, and "Typical" parameters provided can and do vary in different applications. Application examples described herein are for illustrative purposes only. Silicon Labs reserves the right to make changes without further notice and limitation to product information, specifications, and descriptions herein, and does not give warranties as to the accuracy or completeness of the included information. Silicon Labs shall have no liability for the consequences of use of the information supplied herein. This document does not imply or express copyright licenses granted hereunder to design or fabricate any integrated circuits. The products are not designed or authorized to be used within any Life Support System without the specific written consent of Silicon Labs. A "Life Support System" is any product or system intended to support or sustain life and/or health, which, if it fails, can be reasonably expected to result in significant personal injury or death. Silicon Labs products are not designed or authorized for military applications. Silicon Labs products shall under no circumstances be used in weapons of mass destruction including (but not limited to) nuclear, biological or chemical weapons, or missiles capable of delivering such weapons.

**Trademark Information**

Silicon Laboratories Inc.®, Silicon Laboratories®, Silicon Labs®, SiLabs® and the Silicon Labs logo®, Bluegiga®, Bluegiga Logo®, Clockbuilder®, CMEMS®, DSPLL®, EFM®, EFM32®, EFR®, Ember®, Energy Micro, Energy Micro logo and combinations thereof, "the world's most energy friendly microcontrollers", Ember®, EZLink®, EZRadio®, EZRadioPRO®, Gecko®, ISOModem®, Precision32®, ProSLIC®, Simplicity Studio®, SiPHY®, Telegesis, the Telegesis Logo®, USBXpress® and others are trademarks or registered trademarks of Silicon Labs. ARM, CORTEX, Cortex-M3 and THUMB are trademarks or registered trademarks of ARM Holdings. Keil is a registered trademark of ARM Limited. All other products or brand names mentioned herein are trademarks of their respective holders.



**SILICON LABS**

Silicon Laboratories Inc.  
400 West Cesar Chavez  
Austin, TX 78701  
USA

<http://www.silabs.com>

## X-ON Electronics

Largest Supplier of Electrical and Electronic Components

*Click to view similar products for [Development Boards & Kits - Wireless](#) category:*

*Click to view products by [Silicon Labs](#) manufacturer:*

Other Similar products are found below :

[13237ADC-BDM](#) [DA14586-00F02ATDB-P](#) [TWR-13237-KIT](#) [HEATER CLICK](#) [LOAD CELL 2 CLICK](#) [SLWRB4181B](#) [C METER CLICK](#)  
[HALL CURRENT CLICK](#) [COLOR 3 CLICK](#) [COMPASS 2 CLICK](#) [HDC1000 CLICK](#) [RELAY CLICK](#) [RFID CLICK](#) [RIVERDI CLICK](#)  
[CUGSM113#UFL](#) [MATRIX G CLICK](#) [3D MOTION CLICK](#) [4-20MA R CLICK](#) [4-20MA T CLICK](#) [THERMO CLICK](#) [MCP2003B CLICK](#)  
[MCP2542 CLICK](#) [MCP25625 CLICK](#) [ATA8520-EK3-E](#) [TOUCHKEY CLICK](#) [MICROSD CLICK](#) [TRF CLICK](#) [BUTTON R CLICK](#) [I2C](#)  
[ISOLATOR CLICK](#) [UNIQUE ID CLICK](#) [USB SPI CLICK](#) [CAN-SPI CLICK 3.3V](#) [CAN-SPI CLICK 5V](#) [CAP EXTEND CLICK](#)  
[CAPSENSE CLICK](#) [13DOF 2 CLICK](#) [13DOF CLICK](#) [DC MOTOR CLICK](#) [WIFI2 CLICK](#) [4X4 KEY CLICK](#) [4X4 RGB CLICK](#) [DTH22](#)  
[CLICK](#) [RS232 CLICK](#) [RS485 CLICK 3.3V](#) [RTC2 CLICK](#) [EM3588-MLR-AN-C](#) [CC3100 CLICK](#) [FLASH 3 CLICK](#) [NFC CLICK](#) [NFC](#)  
[TAG CLICK](#)