

Si3218x Data Short: ProSLIC[®] Single-Chip FXS Solution

The Si3218x devices are pin-compatible single-channel ProSLIC[®] products that implement a complete foreign exchange station (FXS) telephony interface solution in accordance with all relevant global specifications. The Si3218x ProSLIC ICs operate from a 3.3 V supply and interface to standard PCM/SPI or 3-wire ISI digital interfaces with 3.3 V or 1.8 V I/O. The Si3218x integrated dc-dc controller automatically generates the optimal battery voltages required for each linestate. Si3218x ICs are available with voltage rating of -106 V. The Si3218x devices are available in a 5x6 mm 36-pin QFN package and a 6x6 mm 40-pin QFN Package.

Applications:

- VoIP Gateways and Routers
- xDSL IADs
- Optical Network Terminals/Units (ONT/U)
- Analog Terminal Adapters (ATA)
- Cable eMTA
- Wireless Fixed Terminals (WFT)
- Wireless Local Loop (WLL)
- WiMAX CPE

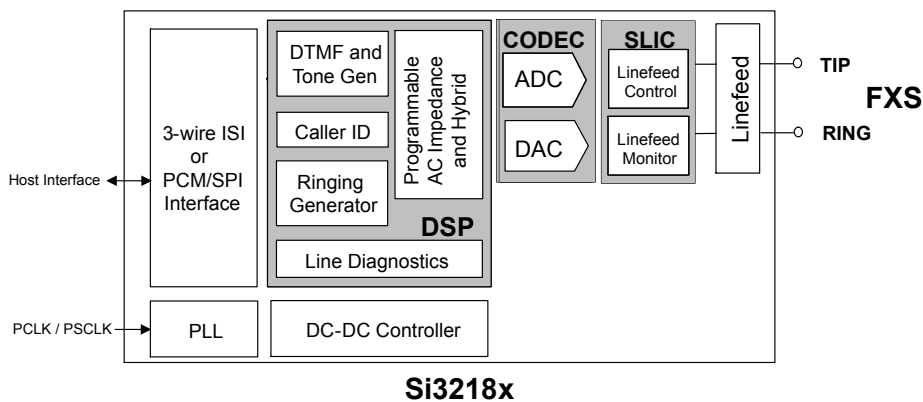

Functional Block Diagram

KEY FEATURES

- Complete FXS solution in a single 5x6 mm or 6x6 mm package
- Performs all BORSCHT functions
- Ideal for short to medium loops
- Global programmability
- Patented low-power ringing
- Simplified configuration and diagnostics
 - Supported by ProSLIC API
 - Audio diagnostics with loopback
 - Integrated test load
- Ultra low power consumption
- Wideband voice support
- On-hook transmission
- Loop or ground start operation
- Smooth polarity reversal
- A-Law/ μ -Law companding, linear PCM
- Flexible integrated tracking dc-dc controller supporting patent-pending low-cost capacitive boost configuration
- Software-programmable parameters:
 - Ringing frequency, amplitude, cadence, and waveshape
 - Two-wire ac impedance
 - Transhybrid balance
 - DC current loop feed (10–45 mA)
 - Loop closure and ring trip thresholds
 - Ground key detect threshold
- Pulse metering
- DTMF generation
- DTMF detection (Si32181/3/5)
- 3.3 V operation
- Support for 1.8 V I/O
- Maximum battery up to -106 V
- Pb-free/RoHS-compliant packaging
- Two digital interface options
 - 3-wire Integrated Serial Interface (ISI) or PCM/SPI interface

Table 1.1. Si3218x Ordering Guide

P/N	Description	Package Type ²	Max V _{BAT}	Temperature
Si32180-A-FM	Wideband FXS, selectable ISI/PCM interface, daisy-chain mode, practical MLT	QFN40	-106 V	0 to 70 °C
Si32180-A-GM	Wideband FXS, selectable ISI/PCM interface, daisy-chain mode, practical MLT	QFN40	-106 V	-40 to 85 °C
Si32181-A-FM	Wideband FXS, selectable ISI/PCM interface, daisy-chain mode, practical MLT, DTMF detection	QFN40	-106 V	0 to 70 °C
Si32181-A-GM	Wideband FXS, selectable ISI/PCM interface, daisy-chain mode, practical MLT, DTMF detection	QFN40	-106 V	-40 to 85 °C
Si32182-A-FM	Wideband FXS, ISI interface, parametric MLT	QFN36	-106 V	0 to 70 °C
Si32182-A-GM	Wideband FXS, ISI interface, parametric MLT	QFN36	-106 V	-40 to 85 °C
Si32183-A-FM	Wideband FXS, ISI interface, parametric MLT, DTMF detection	QFN36	-106 V	0 to 70 °C
Si32183-A-GM	Wideband FXS, ISI interface, parametric MLT, DTMF detection	QFN36	-106 V	-40 to 85 °C
Si32184-A-FM	Wideband FXS, PCM interface, parametric MLT	QFN40	-106 V	0 to 70 °C
Si32184-A-GM	Wideband FXS, PCM interface, parametric MLT	QFN40	-106 V	-40 to 85 °C
Si32185-A-FM	Wideband FXS, PCM interface, parametric MLT, DTMF detection	QFN40	-106 V	0 to 70 °C
Si32185-A-GM	Wideband FXS, PCM interface, parametric MLT, DTMF detection	QFN40	-106 V	-40 to 85 °C

Note:

1. Adding the suffix "R" to the part number (e.g. Si3218x-A-FMR) denotes tape and reel.
2. QFN - Quad-Flat No-leads.

Table 1.2. Ordering Guide—Si3218x Evaluation Kits

Part Number	Description	V _{BAT} Max
Si32183ACB10SL0EVB	ISI Wideband FXS with DTMF detection low-cost capacitive boost dc-dc converter EVB	-100 V
Si32185ACB10SL0EVB	PCM interface, wideband FXS with DTMF detection low-cost capacitive boost dc-dc converter EVB	-100 V

X-ON Electronics

Largest Supplier of Electrical and Electronic Components

Click to view similar products for [Telecom Interface Ics](#) category:

Click to view products by [Silicon Labs](#) manufacturer:

Other Similar products are found below :

[82P2821BHG](#) [MT8888CP1](#) [MT9174AN1](#) [LC850541-E](#) [SI3010-F-FSR](#) [CH1817L](#) [M83262G13](#) [MT8870DNR1](#) [MT88E39ASR1](#)
[MT9074AL1](#) [MT9122AP1](#) [82V2082PFG8](#) [WPCS6051C.B0-900246](#) [MT9074AP1](#) [DS34S102GN+](#) [DS3150TNC1+](#) [Si3050-E1-FTR](#)
[XRT6164CD-F](#) [DS26334GN+](#) [PM4351-NGI](#) [PM5384-NGI](#) [MT88E46AS1](#) [MT8963AE1](#) [MT9076BP1](#) [LE88231DLC](#) [DS26324GNA3+](#)
[82P2521BHG](#) [PM8310A-FEI](#) [PM4351-RI](#) [DS21354LB+](#) [PEF41068FV11 S LL8T](#) [LE9632RQC](#) [LE9622RQC](#) [LE9653AQC](#) [SI3050-E1-GTR](#)
[PEF41068VV12 S LL8U](#) [LE58QL022BVC](#) [LE58QL022BVCT](#) [SI32260-C-FM1R](#) [SI32392-B-GM](#) [82P2917ABBG](#) [SI3019-F-GSR](#)
[EELXT914PC.B3 865795](#) [LE88266DLC](#) [LCP22-150B1RL](#) [W7100A-S2E-100LQFP](#) [USR5686G](#) [MT88L70AS1](#) [DS34S104GN](#)
[DS26514GN+](#)