



SKYWORKS®

Si4844-B20

BROADCAST ANALOG TUNING DIGITAL DISPLAY AM/FM/SW RADIO RECEIVER

Features

- Worldwide FM band support (64–109 MHz)
- Worldwide AM band support (504–1750 kHz)
- SW band support (2.3–28.5 MHz)
- Selectable support for all AM/FM regional bands
- Enhance FM/SW band coverage
- 2-wire control interface
- Mono/Stereo and valid station indicator
- Digital volume support
- Bass/Treble support
- Minimal BOM components with no manual alignment
- Excellent real-world performance
- China TV channels audio carrier reception in FM band
- EN55020 compliant
- Two AAA batteries with 2.0 to 3.6 V supply voltage
- Wide range of ferrite loop sticks and air loop antenna support
- 24-pin SSOP package
- RoHS compliant

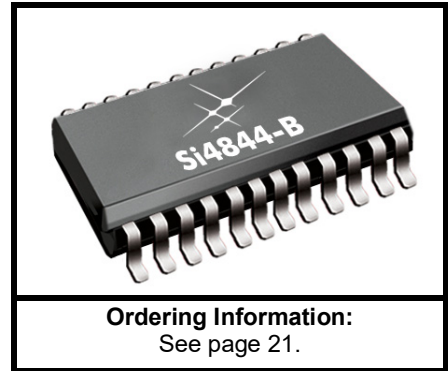

Applications

- Table and portable radios
- Stereos
- Mini/micro systems
- Boom boxes
- Clock radios
- Modules for consumer electronics
- Entertainment systems
- Toys, lamps, and any application needing an AM/FM/SW radio
- Mini HiFi
- iPhone docking

Description

The Si4844-B is the analog-tuned digital-display digital CMOS AM/FM/SW radio receiver IC that integrates the complete receiver function from antenna input to audio output. Working with the host MCU (I²C-compatible 2-wire control interface), frequencies and stereo/mono information can be displayed on LCD while the analog-tune features are kept. Si4844-B is pin-to-pin compatible with the current Si484x-A tuner. Sharing all the advanced features of the Si484x-A, Si4844-B can support a wider range of FM and SW bands. The Si4844-B also supports China TV channels audio reception in FM band. The superior control algorithm integrated in the Si4844-B provides a easy and reliable control interface while eliminating all the manual-tuned external components used in a traditional solution.

Functional Block Diagram

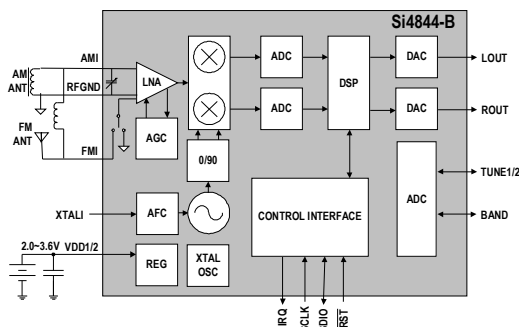

Pin Assignments

Si4844-B20 (SSOP)

LNA_EN	1	24	LOUT
IRQ	2	23	ROUT
TUNE1	3	22	DBYP
TUNE2	4	21	VDD2
BAND	5	20	VDD1
NC	6	19	XTALI
NC	7	18	XTALO
FMI	8	17	SCLK
RFGND	9	16	SDIO
NC	10	15	RST
NC	11	14	GND
AMI	12	13	GND

This product, its features, and/or its architecture is covered by one or more of the following patents, as well as other patents, pending and issued, both foreign and domestic: 7,127,217; 7,272,373; 7,272,375; 7,321,324; 7,355,476; 7,426,376; 7,471,940; 7,339,503; 7,339,504.

TABLE OF CONTENTS

<u>Section</u>	<u>Page</u>
1. Electrical Specifications	4
2. Typical Application Schematic	12
3. Bill of Materials	13
4. Functional Description	14
4.1. Overview	14
4.2. FM Receiver	15
4.3. AM Receiver	15
4.4. SW Receiver	15
4.5. Frequency Tuning	16
4.6. Band Select	16
4.7. Bass and Treble	16
4.8. Volume Control	16
4.9. Stereo Audio Processing	16
4.10. Stereo DAC	17
4.11. Soft Mute	17
4.12. Reference Clock	17
4.13. Reset, Powerup, and Powerdown	17
4.14. Memorizing Status	17
4.15. Programming with Commands	17
5. Commands and Properties	18
6. Pin Description: Si4844-B	20
7. Ordering Guide	21
8. Package Outline: Si4844-B20	22
9. PCB Land Pattern: Si4844-B20	23
10. Top Marking: Si4844-B20	24
11. Additional Reference Resources	25
Document Change List	26

Si4844-B20

1. Electrical Specifications

Table 1. Recommended Operating Conditions^{1,2}

Parameter	Symbol	Test Condition	Min	Typ	Max	Unit
Supply Voltage ³	V_{DD}		2	—	3.6	V
Power Supply Powerup Rise Time	V_{DDRISE}		10	—	—	μ s

Notes:

1. Typical values in the data sheet apply at $V_{DD} = 3.3$ V and 25 °C unless otherwise stated.
2. All minimum and maximum specifications in the data sheet apply across the recommended operating conditions for minimum $V_{DD} = 2.7$ V.
3. Operation at minimum V_{DD} is guaranteed by characterization when V_{DD} voltage is ramped down to 2.0 V. Part initialization may become unresponsive below 2.3 V.

Table 2. DC Characteristics

($V_{DD} = 2.7$ to 3.6 V, $T_A = -15$ to 85 °C)

Parameter	Symbol	Test Condition	Min	Typ	Max	Unit
FM Mode						
Supply Current ¹	I_{FM}		—	21.0	—	mA
Supply Current ²	I_{FM}	Low SNR level	—	21.5	—	mA
AM/SW Mode						
Supply Current ¹	I_{AM}		—	20.0	—	mA
Supplies and Interface						
V_{DD} Powerdown Current	I_{DDPD}		—	10	—	μ A

Notes:

1. Specifications are guaranteed by characterization.
2. LNA is automatically switched to higher current mode for optimum sensitivity in weak signal conditions.

Table 3. Reset Timing Characteristics $(V_{DD} = 2.7 \text{ to } 3.6 \text{ V}, T_A = -15 \text{ to } 85 \text{ }^\circ\text{C})$

Parameter	Symbol	Min	Typ	Max	Unit
RSTB Pulse Width	t_{PRST}	100	—	—	μs
2-wire bus idle time after RSTB rises	t_{SDIO}	100	—	—	μs
2-wire bus idle time before RSTB rises, and VDD valid time before RSTB rises	t_{SRST}	100	—	—	μs
RSTB low time before VDD becomes invalid	t_{RRST}	0	—	—	μs

Notes:

1. RSTB must be held low for at least 100 μs after the voltage supply has been ramped up.
2. RSTB needs to be asserted (pulled low) prior to the supply voltage being ramped down.

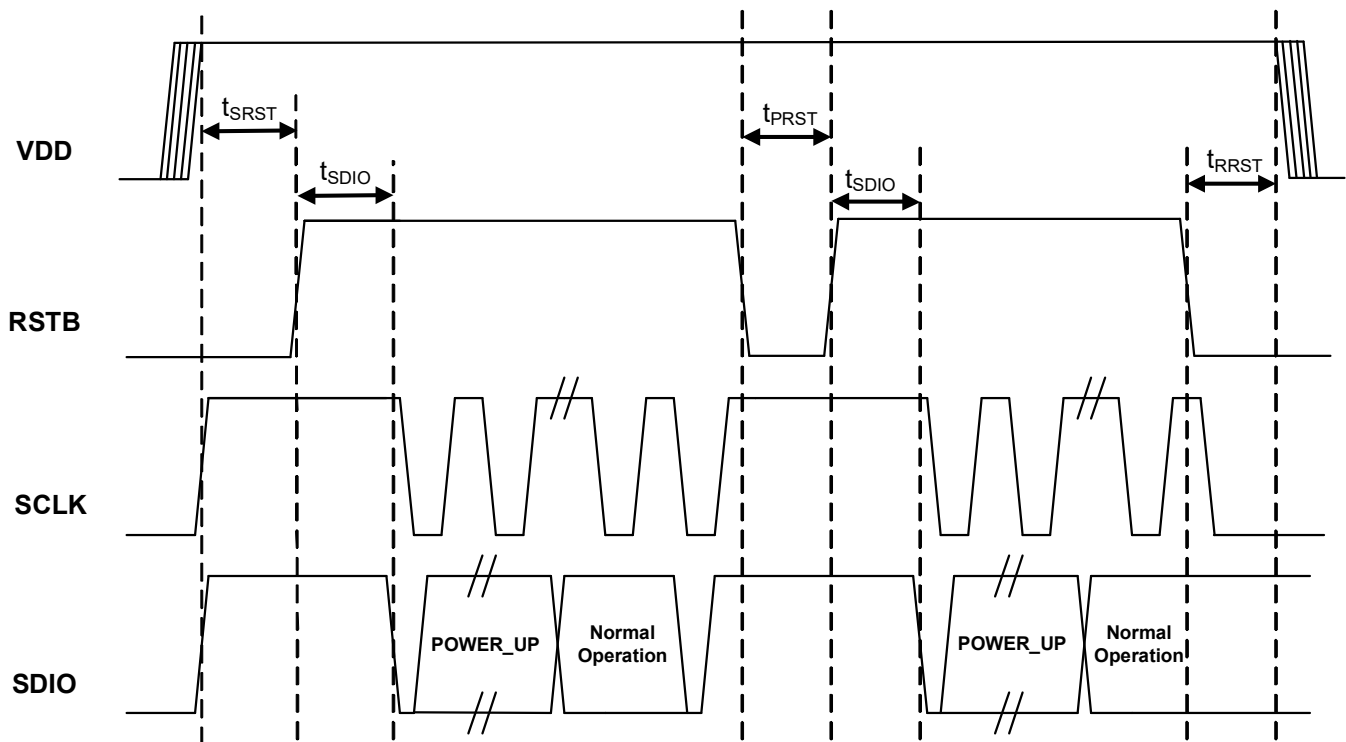
**Figure 1. Reset Timing**

Si4844-B20

Table 4. 2-Wire Control Interface Characteristics^{1,2,3}

($V_{DD} = 2.7$ to 3.6 V, $T_A = -15$ to 85 °C)

Parameter	Symbol	Test Condition	Min	Typ	Max	Unit
SCLK Frequency	f_{SCLK}		0	—	400	kHz
SCLK Low Time	t_{LOW}		1.3	—	—	μ s
SCLK High Time	t_{HIGH}		0.6	—	—	μ s
SCLK Input to SDIO ↓ Setup (START)	$t_{SU:STA}$		0.6	—	—	μ s
SCLK Input to SDIO ↓ Hold (START)	$t_{HD:STA}$		0.6	—	—	μ s
SDIO Input to SCLK ↑ Setup	$t_{SU:DAT}$		100	—	—	ns
SDIO Input to SCLK ↓ Hold ^{4,5}	$t_{HD:DAT}$		0	—	900	ns
SCLK input to SDIO ↑ Setup (STOP)	$t_{SU:STO}$		0.6	—	—	μ s
STOP to START Time	t_{BUF}		1.3	—	—	μ s
SDIO Output Fall Time	$t_{f:OUT}$		$20 + 0.1 \frac{C_b}{1pF}$	—	250	ns
SDIO Input, SCLK Rise/Fall Time	$t_{f:IN}$ $t_{r:IN}$		$20 + 0.1 \frac{C_b}{1pF}$	—	300	ns
SCLK, SDIO Capacitive Loading	C_b		—	—	50	pF
Input Filter Pulse Suppression	t_{SP}		—	—	50	ns

Notes:

1. When $V_D = 0$ V, SCLK and SDIO are low impedance.
2. When selecting 2-wire mode, the user must ensure that a 2-wire start condition (falling edge of SDIO while SCLK is high) does not occur within 300 ns before the rising edge of \overline{RST} .
3. When selecting 2-wire mode, the user must ensure that SCLK is high during the rising edge of \overline{RST} , and stays high until after the first start condition.
4. The Si484x delays SDIO by a minimum of 300 ns from the V_{IH} threshold of SCLK to comply with the minimum $t_{HD:DAT}$ specification.
5. The maximum $t_{HD:DAT}$ has only to be met when $f_{SCLK} = 400$ kHz. At frequencies below 400 kHz, $t_{HD:DAT}$ may be violated as long as all other timing parameters are met.

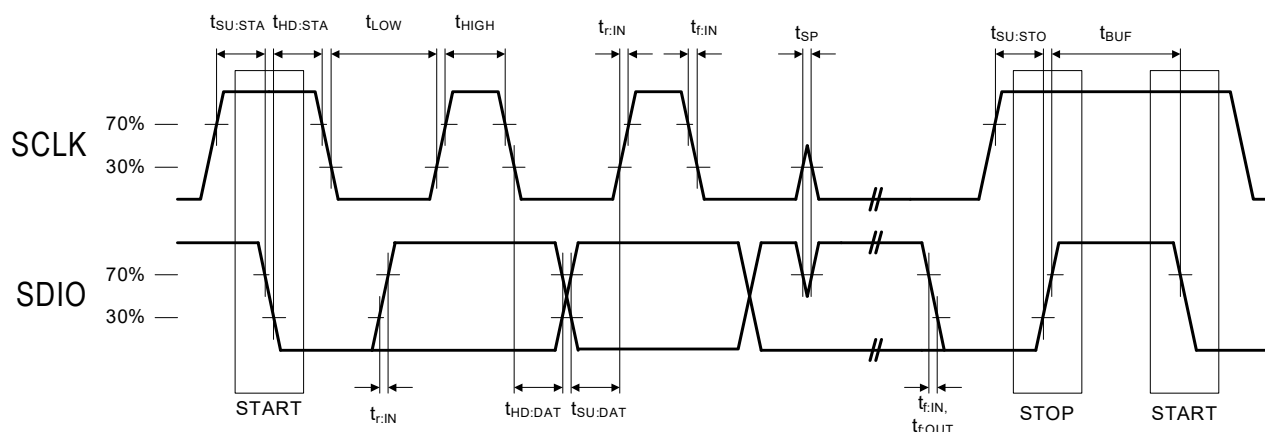

Figure 2. 2-Wire Control Interface Read and Write Timing Parameters

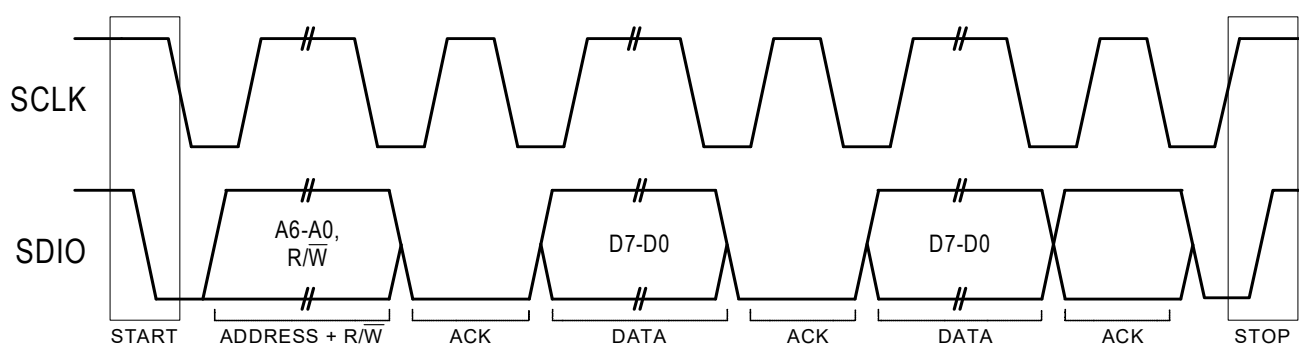

Figure 3. 2-Wire Control Interface Read and Write Timing Diagram

Table 5. FM Receiver Characteristics^{1,2}

($V_{DD} = 2.7$ to 3.6 V, $T_A = -15$ to 85 °C)

Parameter	Symbol	Test Condition	Min	Typ	Max	Unit
Input Frequency	f_{RF}		64	—	109	MHz
Sensitivity with Headphone Network ³		(S+N)/N = 26 dB	—	2.2	—	μ V EMF

Notes:

1. Additional testing information is available in "AN603: Si4822/26/27/40/44 DEMO Board Test Procedure." Volume = maximum for all tests. Tested at $f_{RF} = 98.1$ MHz.
2. To ensure proper operation and receiver performance, follow the guidelines in "AN602: Si4822/26/27/40/44 Antenna, Schematic, Layout, and Design Guidelines." Skyworks will evaluate schematics and layouts for qualified customers.
3. Frequency is 64~109 MHz.
4. Guaranteed by characterization.
5. $V_{EMF} = 1$ mV.
6. $F_{MOD} = 1$ kHz, MONO, and L = R unless noted otherwise.
7. $\Delta f = 22.5$ kHz.
8. $|f_2 - f_1| > 2$ MHz, $f_0 = 2 \times f_1 - f_2$.
9. $B_{AF} = 300$ Hz to 15 kHz, A-weighted.
10. At L_{OUT} and R_{OUT} pins.
11. $\Delta f = 75$ kHz.
12. Tested in Digital Volume Mode.

Si4844-B20

Table 5. FM Receiver Characteristics^{1,2} (Continued)

($V_{DD} = 2.7$ to 3.6 V, $T_A = -15$ to 85 °C)

Parameter	Symbol	Test Condition	Min	Typ	Max	Unit
LNA Input Resistance ^{4,5}			—	4	—	k Ω
LNA Input Capacitance ^{4,5}			—	5	—	pF
AM Suppression ^{4,5,6,7}		m = 0.3	—	50	—	dB
Input IP ^{3,4,8}			—	105	—	dB μ V EMF
Adjacent Channel Selectivity ⁴		± 200 kHz	—	50	—	dB
Alternate Channel Selectivity ⁴		± 400 kHz	—	65	—	dB
Audio Output Voltage ^{5,6,7,12}			—	80	—	mV _{RMS}
Audio Mono S/N ^{5,6,7,9,10}			—	55	—	dB
Audio Stereo S/N ^{3,4,5,7,9,10}			—	55	—	dB
Audio Frequency Response Low ⁴		-3 dB	—	—	30	Hz
Audio Frequency Response High ⁴		-3 dB	15	—	—	kHz
Audio Stereo Separation ^{5,11}			—	40	—	dB
Audio THD ^{5,6,11}			—	0.1	0.5	%
Audio Output Load Resistance ^{4,10}	R _L	Single-ended	10	—	—	k Ω
Audio Output Load Capacitance ^{4,10}	C _L	Single-ended	—	—	50	pF

Notes:

1. Additional testing information is available in “AN603: Si4822/26/27/40/44 DEMO Board Test Procedure.” Volume = maximum for all tests. Tested at RF = 98.1 MHz.
2. To ensure proper operation and receiver performance, follow the guidelines in “AN602: Si4822/26/27/40/44 Antenna, Schematic, Layout, and Design Guidelines.” Skyworks will evaluate schematics and layouts for qualified customers.
3. Frequency is 64~109 MHz.
4. Guaranteed by characterization.
5. $V_{EMF} = 1$ mV.
6. $F_{MOD} = 1$ kHz, MONO, and L = R unless noted otherwise.
7. $\Delta f = 22.5$ kHz.
8. $|f_2 - f_1| > 2$ MHz, $f_0 = 2 \times f_1 - f_2$.
9. $B_{AF} = 300$ Hz to 15 kHz, A-weighted.
10. At L_{OUT} and R_{OUT} pins.
11. $\Delta f = 75$ kHz.
12. Tested in Digital Volume Mode.

Table 6. AM/SW Receiver Characteristics^{1, 2}(V_{DD} = 2.7 to 3.6 V, TA = -15 to 85 °C)

Parameter	Symbol	Test Condition	Min	Typ	Max	Unit
Input Frequency	f _{RF}	Medium Wave (AM)	504	—	1750	kHz
		Short Wave (SW)	2.3	—	28.5	MHz
Sensitivity ^{3,4,5}		(S+N)/N = 26 dB	—	30	—	μV EMF
Large Signal Voltage Handling ⁵		THD < 8%	—	300	—	mV _{RMS}
Power Supply Rejection Ratio ⁵		ΔV _{DD} = 100 mV _{RMS} , 100 Hz	—	40	—	dB
Audio Output Voltage ^{3,6,8}			—	60	—	mV _{RMS}
Audio S/N ^{3,4,6}			—	55	—	dB
Audio THD ^{3,6}			—	0.1	0.5	%
Antenna Inductance ^{5,7}			180	—	450	μH

Notes:

1. Additional testing information is available in "AN603: Si4822/26/27/40/44 DEMO Board Test Procedure." Volume = maximum for all tests. Tested at RF = 520 kHz and RF = 6 MHz.
2. To ensure proper operation and receiver performance, follow the guidelines in "AN602: Si4822/26/27/40/44 Antenna, Schematic, Layout, and Design Guidelines." Skyworks will evaluate schematics and layouts for qualified customers.
3. F_{MOD} = 1 kHz, 30% modulation, 2 kHz channel filter.
4. B_{AF} = 300 Hz to 15 kHz, A-weighted.
5. Guaranteed by characterization.
6. V_{IN} = 5 mV_{rms}.
7. Stray capacitance on antenna and board must be < 10 pF to achieve full tuning range at higher inductance levels.
8. Tested in Digital Volume Mode.

Si4844-B20

Table 7. Reference Clock and Crystal Characteristics

($V_{DD} = 2.7$ to 3.6 V, $T_A = -15$ to 85 °C)

Parameter	Symbol	Test Condition	Min	Typ	Max	Unit
Reference Clock						
XTALI Supported Reference Clock Frequencies*			31.130	32.768	40,000	kHz
Reference Clock Frequency Tolerance for XTALI			-100	—	100	ppm
REFCLK_PRESCALE			1		4095	
REFCLK			31.130	32.768	34.406	kHz
Crystal Oscillator						
Crystal Oscillator Frequency			—	32.768	—	kHz
Crystal Frequency Tolerance			-100	—	100	ppm
Board Capacitance			—	—	3.5	pF
<p>*Note: The Si4844-B20 divides the RCLK input by REFCLK_PROSCALE to obtain REFCLK. There are some RCLK frequencies between 31.130 kHz and 40 MHz that are not supported. For more details, see Table 9 of “AN610: Si48xx ATDD Programming Guide.”</p>						

Table 8. Thermal Conditions

Parameter	Symbol	Min	Typ	Max	Unit
Thermal Resistance*	θ_{JA}	—	80	—	°C/W
Ambient Temperature	T_A	-15	25	85	°C
Junction Temperature	T_J	—	—	92	°C
<p>*Note: Thermal resistance assumes a multi-layer PCB with the exposed pad soldered to a topside PCB pad.</p>					

Table 9. Absolute Maximum Ratings ^{1, 2}

Parameter	Symbol	Value	Unit
Supply Voltage	V_{DD}	-0.5 to 5.8	V
Input Current ³	I_{IN}	10	mA
Operating Temperature	T_{OP}	-40 to 95	°C
Storage Temperature	T_{STG}	-55 to 150	°C
RF Input Level ⁴		0.4	V_{PK}

Notes:

1. Permanent device damage may occur if the above Absolute Maximum Ratings are exceeded. Functional operation should be restricted to the conditions as specified in the operational sections of this data sheet. Exposure beyond recommended operating conditions for extended periods may affect device reliability.
2. The Si4844-B devices are high-performance RF integrated circuits with certain pins having an ESD rating of < 2kV HBM. Handling and assembly of these devices should only be done at ESD-protected workstations.
3. For input pins RST, SDIO, SCLK, XTALO, XTALI, BAND, TUNE2, TUNE1, IRQ, and LNA_EN.
4. At RF input pins, FMI, and AMI.

Si4844-B20

2. Typical Application Schematic

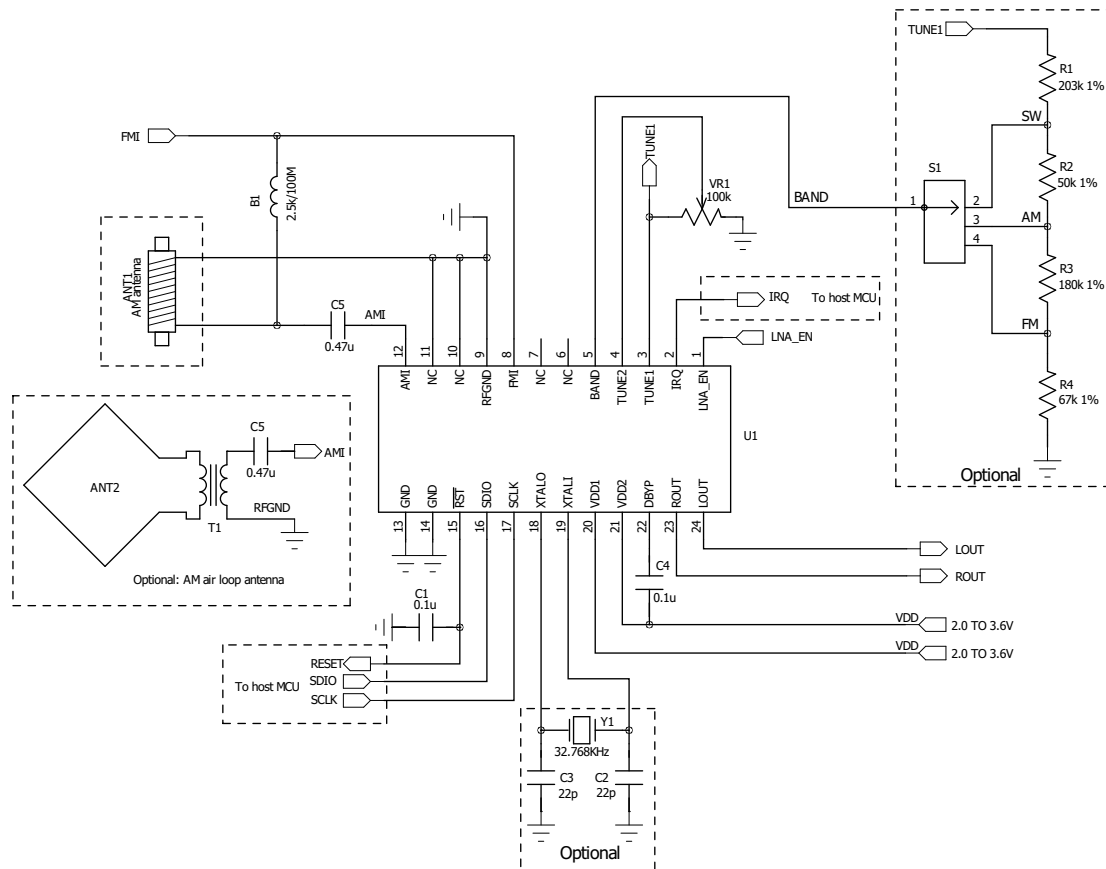

Notes:

1. Place C4 close to VDD2 and DBYP pins.
2. All grounds connect directly to GND plane on PCB.
3. Pin 6 and 7 leave floating.
4. To ensure proper operation and receiver performance, follow the guidelines in “AN602: Si4822/26/27/40/44 Antenna, Schematic, Layout, and Design Guidelines.” Skyworks will evaluate the schematics and layouts for qualified customers.
5. Pin 8 connects to the FM antenna interface and pin 12 connects to the AM antenna interface.
6. Place Si484x as close as possible to antenna jack and keep the FMI and AMI traces as short as possible.
7. Recommend keeping the AM ferrite loop antenna at least 5 cm away from the Si4844-B.
8. Keep the AM ferrite loop antenna away from the MCU, audio amplifier, and other circuits which have AM interference.
9. Place the transformer T1 away from any sources of interference and even away from the I/O signals of the Si4844-B.

3. Bill of Materials

Table 10. Si4844-B20 Bill of Materials

Component(s)	Value/Description	Supplier
C1	Reset capacitor 0.1 μ F, \pm 20%, Z5U/X7R	Murata
C4	Supply bypass capacitor, 0.1 μ F, \pm 20%, Z5U/X7R	Murata
C5	Coupling capacitor, 0.47 μ F, \pm 20%, Z5U/X7R	Murata
B1	Ferrite bead 2.5 k/100 MHz	Murata
VR1	Variable resistor (POT), 100 k, \pm 10%	Kennon
U1	Si4844-B AM/FM/SW Analog Tune Digital Display Radio Tuner	Skyworks
ANT1	Ferrite stick, 180–450 μ H	Jiaxin
Optional Components		
C2, C3	Crystal load capacitors, 22 pF, \pm 5%, COG (Optional: for crystal oscillator option)	Venkel
Y1	32.768 kHz crystal (Optional: for crystal oscillator option)	Epson or equivalent
ANT2	Air loop antenna, 10-20 μ H	various
S1	Band switch	Any, depends on customer
R1	Resistor, 203 k, \pm 1%	Venkel
R2	Resistor, 50 k, \pm 1%	Venkel
R3	Resistor, 180 k, \pm 1%	Venkel
R4	Resistor, 67 k, \pm 1%	Venkel

4. Functional Description

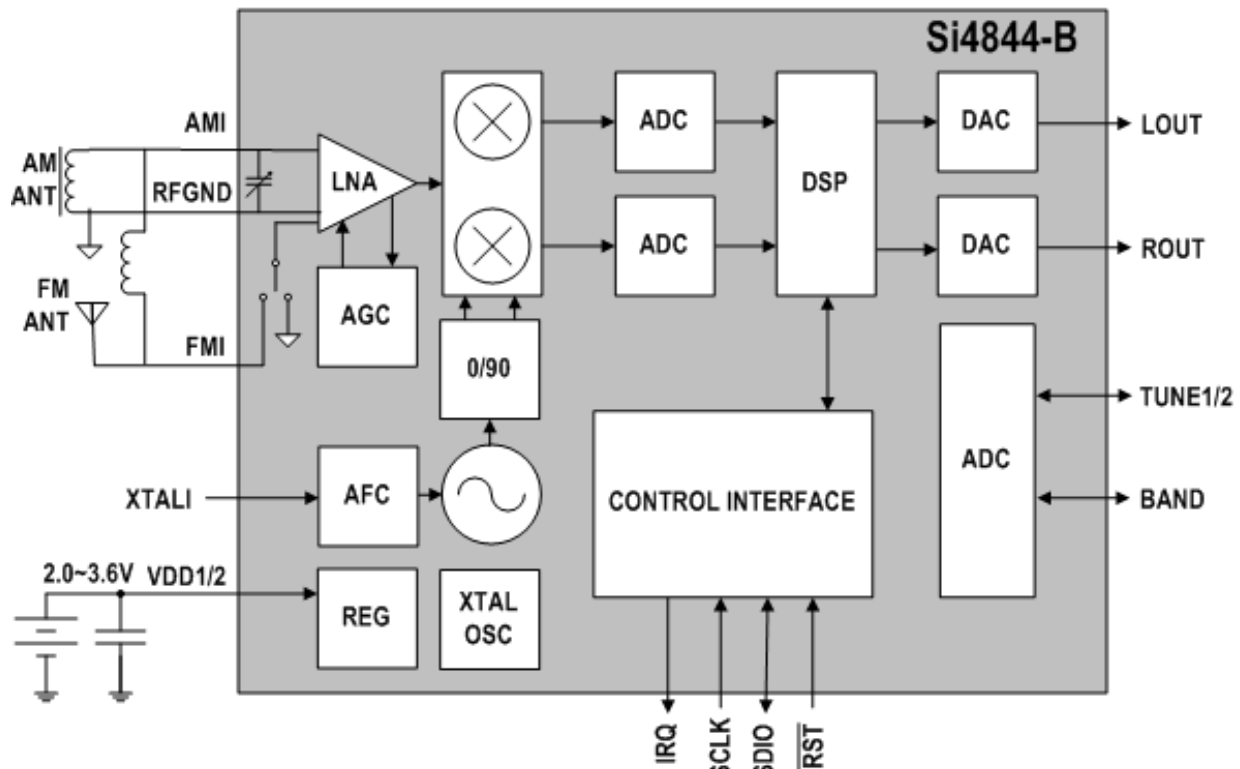

Figure 4. Si4844-B Functional Block Diagram

4.1. Overview

The Si4844-B is the analog-tuned digital-display digital CMOS AM/FM/SW radio receiver IC that integrates the complete receiver function from antenna input to audio output. Working with an external MCU with LCD/LED driver, Si4844-B can output the AM/FM/SW frequencies, band, Bass/Treble and stereo/mono information to display on LCD/LED, while using a simple potentiometer at the front end for analog-tune. Leveraging Skyworks' proven and patented digital low intermediate frequency (low-IF) receiver architecture, the Si4844-B delivers superior RF performance and interference rejection in AM, FM and SW bands. The Si4844-B is pin-to-pin compatible with the current Si484x-A tuning. The Si4844-B shares the advanced features of the Si484x-A and can support a wider range of FM and SW bands. It also supports China TV channels and audio reception in the FM band. The superior control algorithm integrated in Si4844-B provides an easy and reliable control interface while eliminating all the manually tuned external components used in traditional solutions.

Like other successful audio products from Skyworks, Si4844-B offers unmatched integration and PCB space savings with minimum external components and small board area on a single side PCB. The high integration and complete system production test simplifies design-in, increases system quality, and improves manufacturability. The receiver has very low power consumption, runs off two AAA batteries, and delivers the performance benefits of high performance digital radio experience with digital display to the legacy analog-tuned radio market.

The Si4844-B provides good flexibility in using the chip. The frequency range of FM/AM/SW bands, mono/stereo threshold, de-emphasis value, AM tuning step, AM soft mute level/rate, and Bass/Treble can be either configured by the MCU or by using external hardware to make a selection. The reference clock of the FM tuner can be provided either by the crystal or by the host MCU within tolerance.

Si4844-B also has flexibility in selecting bands and configuring band properties, enabling masked Host MCU for multiple projects, and reducing the cost of development. Four tuning preferences are available to meet different tuning preference requirements.

4.2. FM Receiver

The Si4844-B integrates a low noise amplifier (LNA) supporting the worldwide FM broadcast band (64 to 109 MHz) and the TV audio stations within the frequency range in China are also supported. The FM band can also be configured to be a wider range such as 64–108 MHz in one band.

Pre-emphasis and de-emphasis is a technique used by FM broadcasters to improve the signal-to-noise ratio of FM receivers by reducing the effects of high frequency interference and noise. When the FM signal is transmitted, a pre-emphasis filter is applied to accentuate the high audio frequencies. All FM receivers incorporate a de-emphasis filter which attenuates high frequencies to restore a flat frequency response. Two time constants are used in various regions. The de-emphasis time constant can be chosen to be 50 or 75 μ s. Refer to “AN602: Si4822/26/27/40/44 Antenna, Schematic, Layout, and Design Guidelines.”

The Si4844-B also has advanced stereo blending that employs adaptive noise suppression. As a signal quality degrades, the Si4844-B gradually combines the stereo left and right audio channels to a mono audio signal to maintain optimum sound fidelity under varying reception conditions. The Si4844-B can output a stereo signal to MCU with LCD/LED driver to display on the LCD/LED so that the user can easily discern the signal quality.

The stereo on signal is defined using both RSSI and the Left and Right separation levels as these two specifications are the primary factors for stereo listening. The criteria can be set between two conditions: the Left and Right channels are separated by more than 6 dB with RSSI at >20 dB or Left and Right channels are separated by more than 12 dB with RSSI at >28 dB. The selection can be set up using different values of the external resistor or configured by the host MCU. Refer to “AN602: Si4822/26/27/40/44 Antenna, Schematic, Layout, and Design Guidelines.” The user can also refer to the “AN610: Si48xx ATDD Programming Guide” for those who want to configure the value by host MCU.

4.3. AM Receiver

The highly integrated Si4844-B supports worldwide AM band reception from 504 to 1750 kHz with five sub-bands using a digital low-IF architecture with a minimum number of external components and no manual alignment required. This patented architecture allows for high-precision filtering, offering excellent selectivity and SNR with minimum variation across the AM band. Similar to the FM receiver, the Si4844-B optimizes sensitivity and rejection of strong interferers, allowing better reception of weak stations.

To offer maximum flexibility, the receiver supports a wide range of ferrite loop sticks from 180–450 μ H. An air loop antenna is supported by using a transformer to increase the effective inductance from the air loop. Using a 1:5 turn ratio inductor, the inductance is increased by 25 times and easily supports all typical AM air loop antennas, which generally vary between 10 and 20 μ H.

A 9, 10 kHz tuning step can be chosen by the external resistor or host MCU according to the different regions, and AM soft mute level can be programmed by the host MCU to have different tuning experiences. One of the AM bands can be configured as a universal AM band that simultaneously supports 9 kHz and 10 kHz channel spaces for all regional AM standards worldwide. Refer to “AN610: Si48xx ATDD Programming Guide” and “AN602: Si4822/26/27/40/44 Antenna, Schematic, Layout, and Design Guidelines” for more details.

4.4. SW Receiver

The Si4844-B supports short wave band receptions from 2.3 to 28.5 MHz in 5 kHz step size increments. It can also be configured to have a wide SW band that can be used in SW radio with 1 or 2 SW banks. Si4844-B supports extensive short wave features such as minimal discrete components and no factory adjustments. The Si4844 supports using the FM antenna to capture short wave signals. Refer to “AN610: Si48xx ATDD Programming Guide” and “AN602: Si4822/26/27/40/44 Antenna, Schematic, Layout, and Design Guidelines” for more details.

4.5. Frequency Tuning

A valid channel can be found by tuning the potentiometer that is connected to the TUNE1 and TUNE2 pin of the Si4844-B chip.

To offer easy tuning, the Si4844-B also outputs the tuned information to the MCU with LCD/LED driver to display. It will light up the icon on display if the RF signal quality passes a certain threshold when tuned to a valid station. Multiple tuning preferences are available. The user can choose to have the best performance (volume, stereo/mono effect) only at the exact channel, or the best performance in a larger range. Refer to "AN610: Si48xx ATDD Programming Guide" for more details.

4.6. Band Select

The Si4844-B supports worldwide AM band with five sub-bands, US/Europe/Japan/China FM band with five sub-bands, and SW band with 16 sub-bands. Si4844-B provides the flexibility to configure the band and band properties at either the MCU side or the Tuner side, enabling masked MCU for multiple projects. For details on band selection, refer to "AN602: Si4822/26/27/40/44 Antenna, Schematic, Layout, and Design Guidelines" and "AN610: Si48xx ATDD Programming Guide".

4.7. Bass and Treble

The Si4844-B further supports Bass/Treble tone control for superior sound quality. The Si4844-B can be set to be default normal, or programmed by the host MCU I²C-compatible 2-wire mode. FM has nine levels Bass/Treble effect and AM/SW has seven levels Bass/Treble effect. For further configuration details, refer to "AN610: Si48xx ATDD Programming Guide."

4.8. Volume Control

The Si4844-B not only allows users to use the traditional PVR wheel volume control through an external speaker amplifier, it also supports digital volume control programmed by the host MCU. Si4844-B can be programmed to be Bass/Treble mode only or digital volume mode only; it can also be programmed to have the digital volume coexist with Bass/Treble in two modes. Refer to "AN610: Si48xx ATDD Programming Guide" and "AN602: Si4822/26/27/40/44 Antenna, Schematic, Layout, and Design Guidelines" for more details.

4.9. Stereo Audio Processing

The output of the FM demodulator is a stereo multiplexed (MPX) signal. The MPX standard was developed in 1961, and is used worldwide. Today's MPX signal format consists of left + right (L+R) audio, left – right (L–R) audio, a 19 kHz pilot tone.

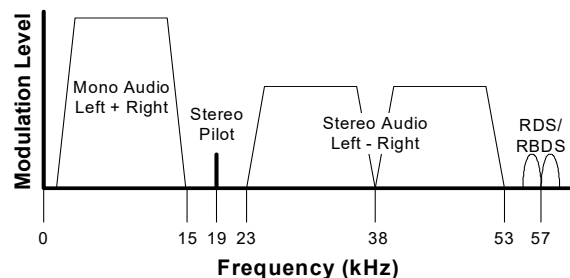

Figure 5. MPX Signal Spectrum

4.9.1. Stereo Decoder

The Si4844-B's integrated stereo decoder automatically decodes the MPX signal using DSP techniques. The 0 to 15 kHz (L+R) signal is the mono output of the FM tuner. Stereo is generated from the (L+R), (L–R), and a 19 kHz pilot tone. The pilot tone is used as a reference to recover the (L–R) signal. Output left and right channels are obtained by adding and subtracting the (L+R) and (L–R) signals respectively.

4.9.2. Stereo-Mono Blending

Adaptive noise suppression is employed to gradually combine the stereo left and right audio channels to a mono (L+R) audio signal as the signal quality degrades to maintain optimum sound fidelity under varying reception conditions. Three metrics, received signal strength indicator (RSSI), signal-to-noise ratio (SNR), and multipath interference, are monitored simultaneously in forcing a blend from stereo to mono. The metric which reflects the minimum signal quality takes precedence and the signal is blended appropriately.

All three metrics have programmable stereo/mono thresholds and attack/release rates. If a metric falls below its mono threshold, the signal is blended from stereo to full mono. If all metrics are above their respective stereo thresholds, then no action is taken to blend the signal. If a metric falls between its mono and stereo thresholds, then the signal is blended to the level proportional to the metric's value between its mono and stereo thresholds, with an associated attack and release rate.

4.10. Stereo DAC

High-fidelity stereo digital-to-analog converters (DACs) drive analog audio signals onto the LOUT and ROUT pins. The audio output may be muted.

4.11. Soft Mute

The soft mute feature is available to attenuate the audio outputs and minimize audible noise in very weak signal conditions. An advanced algorithm is implemented to get a better analog tuning experience. The soft mute feature is triggered by the SNR metric. The SNR threshold for activating soft mute is programmable, as are soft mute attenuation levels and attack and decay rates.

4.12. Reference Clock

The Si4844-B supports programmable RCLK input (to XTALI pin) with the spec listed in Table 7. It can be shared with the host MCU to save extra crystal.

An onboard crystal oscillator is available to generate the 32.768 kHz reference when an external crystal and load capacitors are provided. Refer to "AN602: Si4822/26/27/40/44 Antenna, Schematic, Layout, and Design Guidelines" for more details.

4.13. Reset, Powerup, and Powerdown

Setting the RSTB pin low will disable analog and digital circuitry, reset the registers to their default settings, and disable the bus. Setting the RSTB pin high will bring the device out of reset.

Figure 1 shows typical reset, startup, and shutdown timings for the Si4844-B. RSTB must be held low (asserted) during any power supply transitions and kept asserted as specified in Figure 1 after the power supplies are ramped up and stable. Failure to assert RSTB as indicated here may cause the device to malfunction and may result in permanent device damage.

A powerdown mode is available to reduce power consumption when the part is idle. Putting the device in powerdown mode will disable analog and digital circuitry while keeping the bus active.

4.14. Memorizing Status

The Si4844-B provides the feature to memorize status from the last power down with a simple design on PCB, including frequency of the FM/AM/SW station. Refer to "AN602: Si4822/26/27/40/44 Antenna, Schematic, Layout, and Design Guidelines" for details.

4.15. Programming with Commands

To ease development time and offer maximum customization, the Si4844-B provides a simple yet powerful software interface to program the receiver. The device is programmed using commands, arguments, properties, and responses.

To perform an action, the user writes a command byte and associated arguments, causing the chip to execute the given command. Commands control an action such as powerup the device, shut down the device, or get the current tuned frequency. Arguments are specific to a given command and are used to modify the command.

Properties are a special command argument used to modify the default chip operation and are generally configured immediately after powerup. Examples of properties are de-emphasis and soft mute attenuation threshold.

Responses provide the user information and are echoed after a command and associated arguments are issued. All commands provide a 1-byte status update, indicating interrupt and clear-to-send status information.

For a detailed description of the commands and properties for the Si4844-B, see "AN610: Si48xx ATDD Programming Guide."

Si4844-B20

5. Commands and Properties

Table 11. Si4844-B20 FM Receiver Command Summary

Cmd	Name	Description
0xE0	ATDD_GET_STATUS	Get tune freq, band and etc status of the device.
0xE1	ATDD_POWER_UP	Power up device, band selection and band properties setup.
0xE2	ATDD_AUDIO_MODE	Audio output mode: get/set audio mode and settings.
0x10	GET_REV	Returns the revision information of the device.
0x11	POWER_DOWN	Power down device.
0x12	SET_PROPERTY	Sets the value of a property.
0x13	GET_PROPERTY	Retrieve a property's value.

Note: The Si4844-B has its own power up and get status commands which are different from previous Si47xx tuner parts. To differentiate, we use “ATDD_POWER_UP” and “ATDD_GET_STATUS” to denote the ATDD-specific commands instead of the general Si47xx “POWER_UP” and “STATUS” commands.

Table 12. Si4844-B20 FM Receiver Property Summary

Prop	Name	Description	Default
0x0201	REFCLK_FREQ	Sets frequency of reference clock in Hz. The range is 31130 to 34406 Hz, or 0 to disable the AFC. Default is 32768 Hz.	0x8000
0x0202	REFCLK_PRESCALE	Sets the prescaler value for RCLK input.	0x0001
0x1100	FM_DEEMPHASIS	Sets de-emphasis time constant. Default is 75 μ s.	0x0002
0x1300	FM_SOFT_MUTE_RATE	Sets the attack and decay rates when entering and leaving soft mute.	0x0040
0x1301	FM_SOFT_MUTE_SLOPE	Configures attenuation slope during soft mute in dB attenuation per dB SNR below the soft mute SNR threshold. Default value is 2.	0x0002
0x1302	FM_SOFT_MUTE_MAX_ATTENUATION	Sets maximum attenuation during soft mute (dB). Set to 0 to disable soft mute. Default is 16 dB.	0x0010
0x1303	FM_SOFT_MUTE_SNR_THRESHOLD	Sets SNR threshold to engage soft mute. Default is 4 dB.	0x0004
0x1207	FM_STEREO_IND_BLEND_THRESHOLD	Sets the blend threshold for stereo indicator. Default value is band-dependent (either 0x9F or 0xB2).	0x9F 0xB2
0x1800	FM_BLEND_RSSI_STEREO_THRESHOLD	Sets RSSI threshold for stereo blend. (Full stereo above threshold, blend below threshold.) To force stereo, set this to 0. To force mono, set this to 127. Default value is 49 dB μ V.	0x0031
0x1801	FM_BLEND_RSSI_MONO_THRESHOLD	Sets RSSI threshold for mono blend (Full mono below threshold, blend above threshold). To force stereo, set this to 0. To force mono, set this to 127. Default value is band-dependent (either 8 or 7).	0x0008 0x0007
0x4000	RX_VOLUME	Sets the output volume.	0x003F
0x4001	RX_HARD_MUTE	Mutes the audio output. L and R audio outputs may be muted independently.	0x0000
0x4002	RX_BASS_TREBLE	Sets the output bass/treble level.	0x0004
0x4003	RX_ACTUAL_VOLUME	Reads the actual output volume.	0x003F

Table 13. Si4844-B20 AM/SW Receiver Command Summary

Cmd	Name	Description
0xE0	ATDD_GET_STATUS	Get tune freq, band and etc status of the device.
0xE1	ATDD_POWER_UP	Power up device, band selection and band properties setup
0xE2	ATDD_AUDIO_MODE	Audio output mode: get/set audio mode settings.
0x10	GET_REV	Returns the revision information of the device.
0x11	POWER_DOWN	Power down device.
0x12	SET_PROPERTY	Sets the value of a property.
0x13	GET_PROPERTY	Retrieve a property's value.

Note: The Si4844-B has its own power up and get status commands which are different from previous Si47xx tuner parts. To differentiate, we use "ATDD_POWER_UP" and "ATDD_GET_STATUS" to denote the ATDD-specific commands instead of the general Si47xx "POWER_UP" and "STATUS" commands.

Table 14. Si4844-B20 AM/SW Receiver Property Summary

Prop	Name	Description	Default
0x0201	REFCLK_FREQ	Sets frequency of reference clock in Hz. The range is 31330 to 34406 Hz, or 0 to disable the AFC. Default is 32768 Hz.	0x8000
0x0202	REFCLK_PRESCALE	Sets the prescaler value for RCLK input.	0x0001
0x4000	RX_VOLUME	Sets the output volume.	0x003F
0x4001	RX_HARD_MUTE	Mutes the audio output. L and R audio outputs may be muted independently.	0x0000
0x4002	RX_BASS_TREBLE	Sets the output bass/treble level.	0x0003
0x4003	RX_ACTUAL_VOLUME	Read the actual output volume	0x003F
0x3300	AM_SOFT_MUTE_RATE	Sets the attack and decay rates when entering and leaving soft mute.	0x0040
0x3301	AM_SOFT_MUTE_SLOPE	Configures attenuation slope during soft mute in dB attenuation per dB SNR below the soft mute SNR threshold.	0x0002
0x3302	AM_SOFT_MUTE_MAX_ATTENUATION	Sets maximum attenuation during soft mute (dB). Set to 0 to disable soft mute.	0x0010
0x3303	AM_SOFT_MUTE_SNR_THRESHOLD	Sets SNR threshold to engage soft mute.	0x0008

Si4844-B20

6. Pin Description: Si4844-B

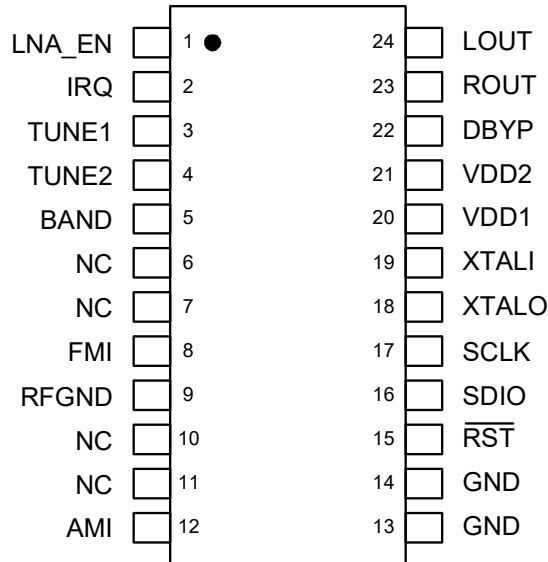

Pin Number(s)	Name	Description
1	LNA_EN	Enabling SW external LNA
2	IRQ	Interrupt Request
3	TUNE1	Frequency tuning
4	TUNE2	Frequency tuning
5	BAND	Band selection and De-emphasis/Stereo separation selection
6,7	NC	No connect. Leave floating.
8	FMI	FM RF inputs. FMI should be connected to the antenna trace.
9	RFGND	RF ground. Connect to ground plane on PCB.
10, 11	NC	Unused. Tie these pins to GND.
12	AMI	AM RF input. AMI should be connected to the AM antenna.
13, 14	GND	Ground. Connect to ground plane on PCB.
15	$\overline{\text{RST}}$	Device reset (active low) input
16	SDIO	Serial data input/output
17	SCLK	Serial clock input
18	XTALO	Crystal oscillator output
19	XTALI	Crystal oscillator input /external reference clock input.
20	VDD1	Supply voltage. May be connected directly to battery.
21	VDD2	Supply voltage. May be connected directly to battery.
22	DBYP	Dedicated bypass for VDD
23	ROUT	Right audio output
24	LOUT	Left audio output

7. Ordering Guide

Part Number*	Description	Package Type	Operating Temperature/Voltage
Si4844-B20-GU	AM/FM/SW Broadcast Radio Receiver	24L SSOP Pb-free	-15 to 85 °C 2.0 to 3.6 V

***Note:** Add an "(R)" at the end of the device part number to denote tape and reel option. The devices will typically operate at 25 °C with degraded specifications for V_{DD} voltage ramped down to 2.0 V.

Si4844-B20

8. Package Outline: Si4844-B20

The 24-pin SSOP illustrates the package details for the Si4844-B20. Table 15 lists the values for the dimensions shown in the illustration.

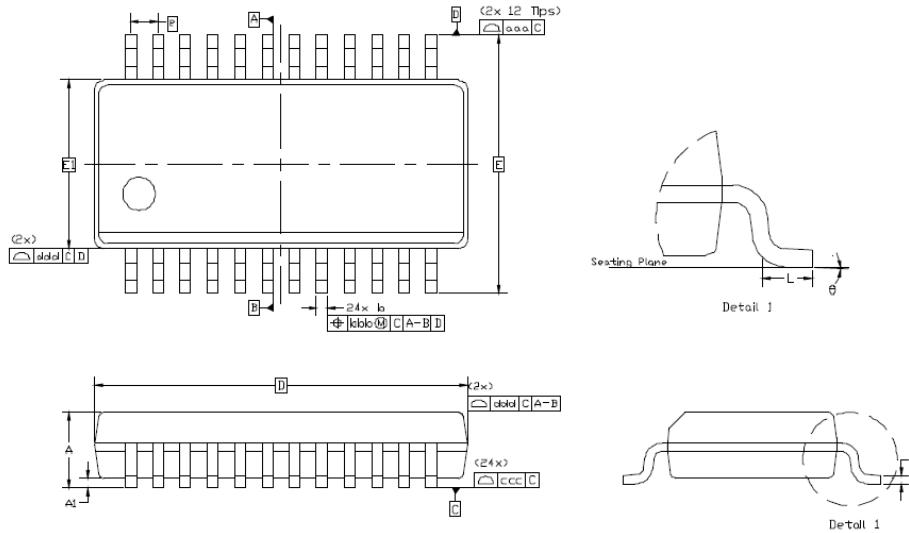

Figure 6. 24-Pin SSOP

Table 15. Package Dimensions

Dimension	Min	Nom	Max
A	—	—	1.75
A1	0.10	—	0.25
b	0.20	—	0.30
c	0.10	—	0.25
D	8.65 BSC		
E	6.00 BSC		
E1	3.90 BSC		
e	0.635 BSC		
L	0.40	—	1.27
θ	0°	—	8°
aaa	0.20		
bbb	0.18		
ccc	0.10		
ddd	0.10		

Notes:

1. All dimensions shown are in millimeters (mm) unless otherwise noted.
2. Dimensioning and Tolerancing per ANSI Y14.5M-1994.
3. This drawing conforms to the JEDEC Solid State Outline MO-137, Variation AE.
4. Recommended card reflow profile is per the JEDEC/IPC J-STD-020 specification for Small Body Components.

9. PCB Land Pattern: Si4844-B20

Figure 7 illustrates the PCB land pattern details for the Si4844-B20-GU SSOP. Table 16 lists the values for the dimensions shown in the illustration.

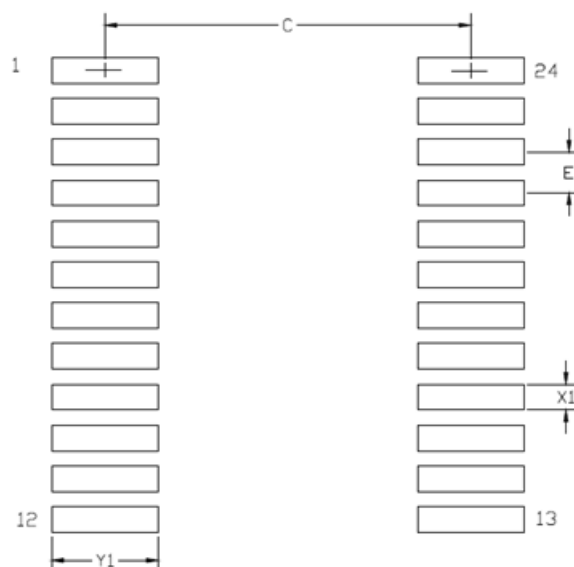

Figure 7. PCB Land Pattern

Table 16. PCB Land Pattern Dimensions

Dimension	Min	Max
C	5.20	5.40
E	0.635 BSC	
X1	0.35	0.45
Y1	1.55	1.75

General:

- All dimensions shown are in millimeters (mm) unless otherwise noted.
- This land pattern design is based on the IPC-7351 guidelines.

Solder Mask Design:

- All metal pads are to be non-solder mask defined (NSMD). Clearance between the solder mask and the metal pad is to be 60 μm minimum, all the way around the pad.

Stencil Design:

- A stainless steel, laser-cut, and electro-polished stencil with trapezoidal walls should be used to assure good solder paste release.
- The stencil thickness should be 0.125 mm (5 mils).
- The ratio of stencil aperture to land pad size should be 1:1 for all perimeter pads.

Card Assembly:

- A No-Clean, Type-3 solder paste is recommended.
- The recommended card reflow profile is per the JEDEC/IPC J-STD-020 specification for Small Body Components.

Si4844-B20

10. Top Marking: Si4844-B20

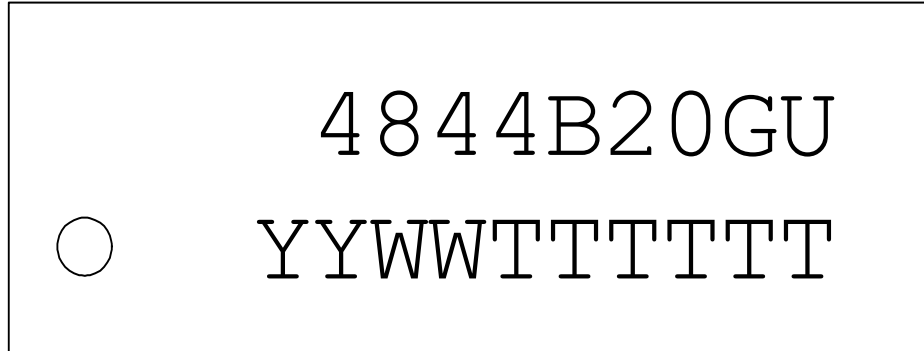

Mark Method:	YAG Laser	
Line 1 Marking:	Device identifier	4844B20GU = Si4844-B20
Line 2 Marking:	YY = Year WW = Work week TTTTTT = Manufacturing code	Assigned by the Assembly House.

11. Additional Reference Resources

Contact your local sales representatives for more information or to obtain copies of the following references:

- EN55020 Compliance Test Certificate
- AN602: Si4822/26/27/40/44 Antenna, Schematic, Layout, and Design Guidelines
- AN603: Si4822/26/27/40/44 DEMO Board Test Procedure
- Si4844-DEMO Board User's Guide
- AN610: Si48xx-ATDD Programming Guide

DOCUMENT CHANGE LIST

Revision 0.1 to Revision 1.0

- Updated “Features”
- Updated Table 3. “Reset Timing Characteristics”
- Updated Table 5. “FM Receiver Characteristics”
- Updated Table 6. “AM/SW Receiver Characteristics”
- Updated Section 4.3. “AM Receiver”
- Inserted Section 4.13. “Reset, Powerup, and Powerdown”
- Updated Section 6. “Pin Description: Si4844-B”



SKYWORKS®

**Connecting Everyone
and Everything,
All the Time**



Portfolio

www.skyworksinc.com

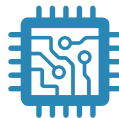

Quality

www.skyworksinc.com/quality



Support & Resources

www.skyworksinc.com/support

Copyright © 2021 Skyworks Solutions, Inc. All Rights Reserved.

Information in this document is provided in connection with Skyworks Solutions, Inc. ("Skyworks") products or services. These materials, including the information contained herein, are provided by Skyworks as a service to its customers and may be used for informational purposes only by the customer. Skyworks assumes no responsibility for errors or omissions in these materials or the information contained herein. Skyworks may change its documentation, products, services, specifications or product descriptions at any time, without notice. Skyworks makes no commitment to update the materials or information and shall have no responsibility whatsoever for conflicts, incompatibilities, or other difficulties arising from any future changes.

No license, whether express, implied, by estoppel or otherwise, is granted to any intellectual property rights by this document. Skyworks assumes no liability for any materials, products or information provided hereunder, including the sale, distribution, reproduction or use of Skyworks products, information or materials, except as may be provided in Skyworks' Terms and Conditions of Sale.

THE MATERIALS, PRODUCTS AND INFORMATION ARE PROVIDED "AS IS" WITHOUT WARRANTY OF ANY KIND, WHETHER EXPRESS, IMPLIED, STATUTORY, OR OTHERWISE, INCLUDING FITNESS FOR A PARTICULAR PURPOSE OR USE, MERCHANTABILITY, PERFORMANCE, QUALITY OR NON-INFRINGEMENT OF ANY INTELLECTUAL PROPERTY RIGHT; ALL SUCH WARRANTIES ARE HEREBY EXPRESSLY DISCLAIMED. SKYWORKS DOES NOT WARRANT THE ACCURACY OR COMPLETENESS OF THE INFORMATION, TEXT, GRAPHICS OR OTHER ITEMS CONTAINED WITHIN THESE MATERIALS. SKYWORKS SHALL NOT BE LIABLE FOR ANY DAMAGES, INCLUDING BUT NOT LIMITED TO ANY SPECIAL, INDIRECT, INCIDENTAL, STATUTORY, OR CONSEQUENTIAL DAMAGES, INCLUDING WITHOUT LIMITATION, LOST REVENUES OR LOST PROFITS THAT MAY RESULT FROM THE USE OF THE MATERIALS OR INFORMATION, WHETHER OR NOT THE RECIPIENT OF MATERIALS HAS BEEN ADVISED OF THE POSSIBILITY OF SUCH DAMAGE.

Skyworks products are not intended for use in medical, lifesaving or life-sustaining applications, or other equipment in which the failure of the Skyworks products could lead to personal injury, death, physical or environmental damage. Skyworks customers using or selling Skyworks products for use in such applications do so at their own risk and agree to fully indemnify Skyworks for any damages resulting from such improper use or sale.

Customers are responsible for their products and applications using Skyworks products, which may deviate from published specifications as a result of design defects, errors, or operation of products outside of published parameters or design specifications. Customers should include design and operating safeguards to minimize these and other risks. Skyworks assumes no liability for applications assistance, customer product design, or damage to any equipment resulting from the use of Skyworks products outside of Skyworks' published specifications or parameters.

Skyworks, the Skyworks symbol, Sky5®, SkyOne®, SkyBlue™, Skyworks Green™, Clockbuilder®, DSPLL®, ISOModem®, ProSLIC®, and SiPHY® are trademarks or registered trademarks of Skyworks Solutions, Inc. or its subsidiaries in the United States and other countries. Third-party brands and names are for identification purposes only and are the property of their respective owners. Additional information, including relevant terms and conditions, posted at www.skyworksinc.com, are incorporated by reference.

X-ON Electronics

Largest Supplier of Electrical and Electronic Components

Click to view similar products for [RF Receiver](#) category:

Click to view products by [Silicon Labs](#) manufacturer:

Other Similar products are found below :

[MICRF011YN](#) [TDA5240](#) [TDA5201XT](#) [TDA5225](#) [ATA8205P6C-TKQW](#) [VRC522](#) [MICRF229YQS](#) [SI4825-A10-CS](#) [SI4730-D60-GMR](#)
[MICRF219AAYQS](#) [AW13412DNR](#) [LT5504EMS8#PBF](#) [AD6677BCPZ](#) [AD6641BCPZ-500](#) [AD6643BCPZ-200](#) [AD6643BCPZ-250](#)
[AD6649BCPZ](#) [AD6649BCPZRL7](#) [AD6650ABC](#) [AD6652BBCZ](#) [AD6655ABCPZ-125](#) [AD6655ABCPZ-150](#) [AD6655ABCPZ-80](#)
[AD6657ABBCZ](#) [AD6657BBCZ](#) [AD6673BCPZ-250](#) [AD6674-1000EBZ](#) [AD6674BCPZ-1000](#) [AD6674BCPZ-500](#) [AD6676BCBZRL](#)
[AD6679BBPZ-500](#) [ADRV9008BBCZ-1](#) [AD9864BCPZ](#) [AD9864BCPZRL](#) [ADAR2004ACCZ](#) [AD9874ABST](#) [HMC8100LP6JE](#)
[LTC5556IUH#PBF](#) [BGT24MR2E6327XUMA1](#) [TDA5211](#) [MICRF011YM](#) [MAX7036GTP/V+](#) [MAX2141ETH/V+](#) [MAX7033EUI+](#)
[MAX1473EUI+T](#) [MAX1473EUI+](#) [MAX1470EUI+](#) [MAX7034AUI+](#) [MAX7034AUI/V+](#) [MAX7036GTP+](#)