

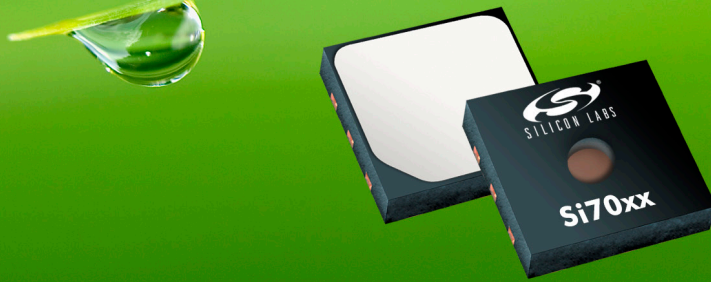

Humidity and Temperature Sensors

www.silabs.com/humidity-sensor



The simpler, greener way to measure relative humidity

FEATURES

- Precision Relative Humidity Sensor:
 - Si7013/21: $\pm 3\%$ RH (maximum) @ 0–80% RH
 - Si7020: $\pm 4\%$ RH (maximum) @ 0–80% RH
- Temperature Sensor:
 - $\pm 0.4\text{ }^\circ\text{C}$ accuracy (maximum) @ -10 to $+85\text{ }^\circ\text{C}$
- Auxiliary 2nd zone sensor input (Si7013)
- 0 to 100% RH operating range
- Up to -40 to $+125\text{ }^\circ\text{C}$ operating range
- Wide operating voltage range (1.9 to 3.6 V)
- Low Power Consumption:
 - $1.9\text{ }\mu\text{W}$ average power at 3.3 V and 1 sample per second
- I²C host interface
- Integrated on-chip heater
- 3 mm x 3 mm DFN package
- Excellent long term stability
- Factory calibrated
- Optional factory-installed filter/cover
 - Lifetime protection during reflow and in operation
 - Protects against contamination from dust, dirt, household chemicals and other liquids
- AEC-Q100 automotive qualified

APPLICATIONS

- Industrial HVAC/R
- Thermostats/humidistats
- Respiratory therapy
- White goods
- Micro-environments/data centers
- Automotive climate control and de-fogging
- Asset and goods tracking

LOWEST POWER INTEGRATED RH SENSOR

DIGITAL I²C HUMIDITY AND TEMPERATURE SENSORS

The Si701x/2x devices are Silicon Labs' 2nd generation family of relative humidity and temperature sensors. All members of this device family combine fully factory-calibrated humidity and temperature sensor elements with an analog to digital converter, signal processing and an I²C host interface. Patented use of industry-standard low-K polymer dielectrics provides excellent accuracy and long term stability, along with low drift and low hysteresis. The innovative CMOS design also offers the lowest power consumption in the industry for a relative humidity and temperature sensor.

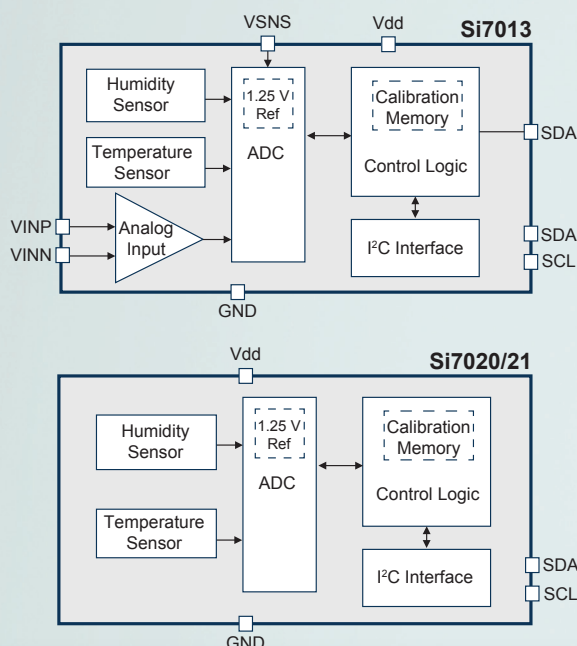



Humidity and Temperature Sensors

www.silabs.com/humidity-sensor

Si70xx Development Tools

The Si70xx is supported by a suite of hardware and software development tools that facilitate testing/characterization, prototyping and software development.

The **Si7013USB-DONGLE** Evaluation Kit comes with everything developers need to demonstrate and evaluate the Si7013. The board plugs into a PC via a USB socket. It has a connector for adding the Si7013/20/21-EB Daughter Cards.

The **Si7013, Si7020 and Si7021-EB** (included with the Si7013USB-DONGLE) are three small daughter cards that permit evaluation of the Si70xx at the end of a flex cable. They plug right in to the USB-DONGLE if the user wants to put a sensor in a temperature/humidity chamber or a product prototype.

The **Si7013EVB-UDP** is a small daughter card that permits evaluation of the Si7013 in conjunction with certain Unified Development Platform (UDP) components such as the C8051F960 8-bit and the SiM3L1xx LCD 32-bit Ultra-Low Power Microcontroller Development Kits. It plugs directly into UDP MCU cards for fast prototyping and software development. In addition to an on-board Si7013, there is a connector for adding an Si7013/20/21-EB via its flex cable, allowing the user to place the Si7013 in a temperature/humidity chamber or a product prototype.

The **Si7005EVB-UDP-F960** Development Kit and **Si7013EVB-UDP-M3L1** Development Kit combines the 8-bit or 32-bit Ultra-Low Power Microcontroller Development Kits and the Si7013EVB-UDP daughter card with data logger demonstration code. It is a complete package designed to support hardware and software development using the Si7013 and Silicon Lab's ultra-low power MCUs. It ships with example software that implements a portable, battery-powered data logger/asset tracker.

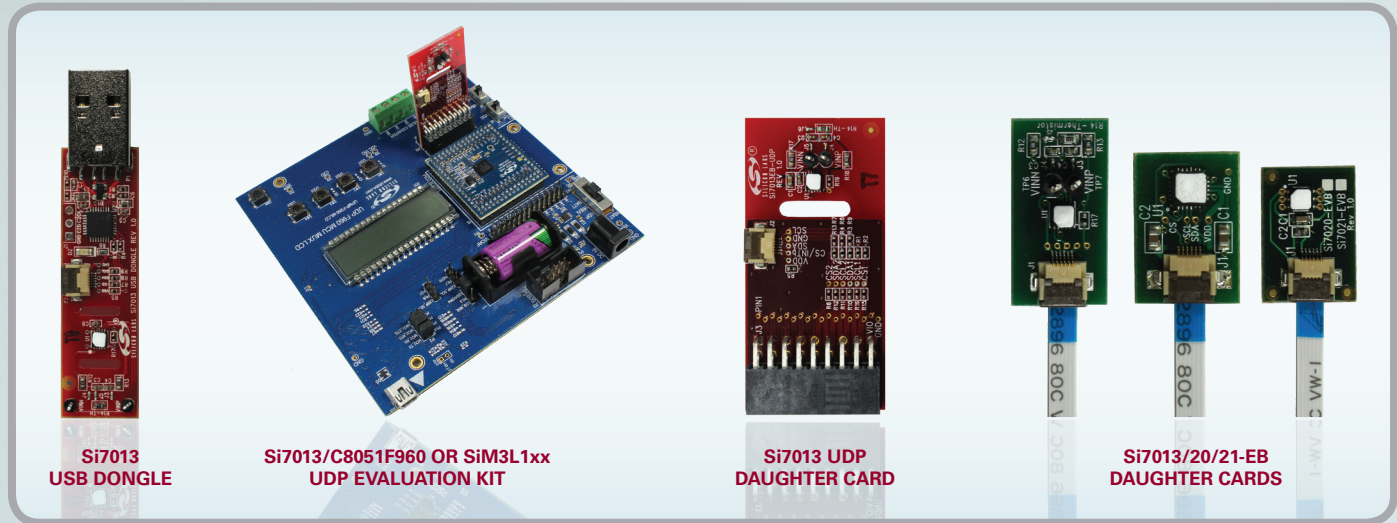

**Si7013
USB DONGLE**

**Si7013/C8051F960 OR SiM3L1xx
UDP EVALUATION KIT**

**Si7013 UDP
DAUGHTER CARD**

**Si7013/20/21-EB
DAUGHTER CARDS**

Digital I²C Relative Humidity and Temperature Sensors

PART NUMBER	DESCRIPTION	MAX ACCURACY TEMP.	RH	TEMP. RANGE	FILTER COVER	PACKAGE FORMAT	PACKAGE
Si7013-A10-GM	Digital I ² C RH and 2-zone temperature sensor IC	±0.4 °C	±3%	-40 to 85 °C		Tube	DFN10
Si7013-A10-GM1R	Digital I ² C RH and 2-zone temperature sensor IC with pre-installed protective cover	±0.4 °C	±3%	-40 to 85 °C	•	Cut Tape	DFN10
Si7013-A10-IM	Digital I ² C RH and 2-zone temperature sensor IC	±0.4 °C	±3%	-40 to 125 °C		Tube	DFN10
Si7013-A10-IM1R	Digital I ² C RH and 2-zone temperature sensor IC with pre-installed protective cover	±0.4 °C	±3%	-40 to 125 °C	•	Cut Tape	DFN10
Si7020-A10-GM	Digital I ² C RH and temperature sensor IC	±0.4 °C	±4%	-40 to 85 °C		Tube	DFN6
Si7020-A10-GM1R	Digital I ² C RH and temperature sensor IC with pre-installed protective cover	±0.4 °C	±4%	-40 to 85 °C	•	Cut Tape	DFN6
Si7020-A10-IM	Digital I ² C RH and temperature sensor IC	±0.4 °C	±4%	-40 to 125 °C		Tube	DFN6
Si7020-A10-IM1R	Digital I ² C RH and temperature sensor IC with pre-installed protective cover	±0.4 °C	±4%	-40 to 125 °C	•	Cut Tape	DFN6
Si7021-A10-GM	Digital I ² C RH and temperature sensor IC	±0.4 °C	±3%	-40 to 85 °C		Tube	DFN6
Si7021-A10-GM1R	Digital I ² C RH and temperature sensor IC with pre-installed protective cover	±0.4 °C	±3%	-40 to 85 °C	•	Cut Tape	DFN6
Si7021-A10-IM	Digital I ² C RH and temperature sensor IC	±0.4 °C	±3%	-40 to 125 °C		Tube	DFN6
Si7021-A10-IM1R	Digital I ² C RH and temperature sensor IC with pre-installed protective cover	±0.4 °C	±3%	-40 to 125 °C	•	Cut Tape	DFN6

X-ON Electronics

Largest Supplier of Electrical and Electronic Components

Click to view similar products for [Board Mount Humidity Sensors](#) category:

Click to view products by [Silicon Labs](#) manufacturer:

Other Similar products are found below :

[HSHCAA114A](#) [SI7020-A10-IM](#) [SI7020-A20-IMR](#) [SI7023-A20-IM1R](#) [SI7021-A20-YM0](#) [SI7021-A20-IMR](#) [SI7013-A10-IM1](#) [SI7021-A20-IM1R](#) [SI7007-A20-IMR](#) [SI7021-A10-IM1](#) [LCSC-20S-B](#) [LCSC-30S-B](#) [LCSC-30S-MD](#) [LCSC-30S-ML](#) [LCSC-30S-HX](#) [LCSC-SHT30S-JCB](#) [LCSC-30S-HE](#) [LCSC-30S-HERS](#) [LCSC-30S-B-550-XDG](#) [TH30S-B](#) [CFSTM-UB3-U](#) [MGS-2-01](#) [HPP845E031R4](#) [HPP845E131R5](#) [MGS-3-01](#) [HTU21D](#) [CC2D35S-SIP](#) [CC2D33S-SIP](#) [CC2D33-SIP](#) [CC2D23S-SIP](#) [CC2D23-SIP](#) [251-10509](#) [HDC1050DMBR](#) [HIH6131-021-001](#) [HIH-4000-004](#) [HIH-4000-002](#) [HIH7120-021-001](#) [HIH6130-021-001](#) [SI2144-A20-GMR](#) [SI5332DC09118-GM1](#) [HIH-4031-001S](#) [SHT35-DIS-F2.5kS](#) [HIH-4020-003](#) [HIH-4031-003S](#) [SHT30-DIS-F2.5kS](#) [HDC2010YPAR](#) [HDC2010YPAT](#) [HIH-4030-003S](#) [HIH-4030-001S](#) [SI7006-A20-IMR](#)