

3-Channel Clock Distribution Buffer

Key Features	Description
<ul style="list-style-type: none"> • Low current consumption - 2.7mA-typ (VDD=1.8V and CL=0) • 1.7V to 3.65V power supply operation • 10MHz to 52MHz CLKIN • Supports LVCMOS and clipped sine wave inputs • Supports 3 single-ended LVCMOS square wave outputs • OE1/2/3 functions for each CLKOUT1/2/3 outputs • OE_OSC control pin to enable external TCXO/XO • Ultra-Low phase noise • Ultra low standby current • 10-pin TDFN package (1.4x2.0x0.75 mm) • Industrial -40 °C to 85 °C temperature range 	<p>The SL18860DC product is a high performance 3 output clock distribution buffer and provides 3 outputs from a single input clock by using SLI proprietary low phase noise and low power dissipation circuit design.</p> <p>The SL18860DC can be used in baseband mobile RF applications including WLAN, Bluetooth and DVB-H as an input clock reference. The product designed to isolate each device driven by their clock outputs to minimize interference between these devices.</p> <p>Each of the clock buffer outputs can be individually disabled by using OE1/2/3 control pins to reduce the power consumption if the connected device does not need the clock. The device operates from single power supply from 1.7V to 3.65V and from -40 °C to 85 °C.</p>
<p>Application</p> <ul style="list-style-type: none"> • Smart Mobile Handsets • Multi-mode RF Clock Distribution • Baseband Peripheral Clock Distribution 	<p>Benefits</p> <ul style="list-style-type: none"> • Fast Time-to-market • Cost Reduction • Low Power Dissipation • Low Phase Noise

Block Diagram

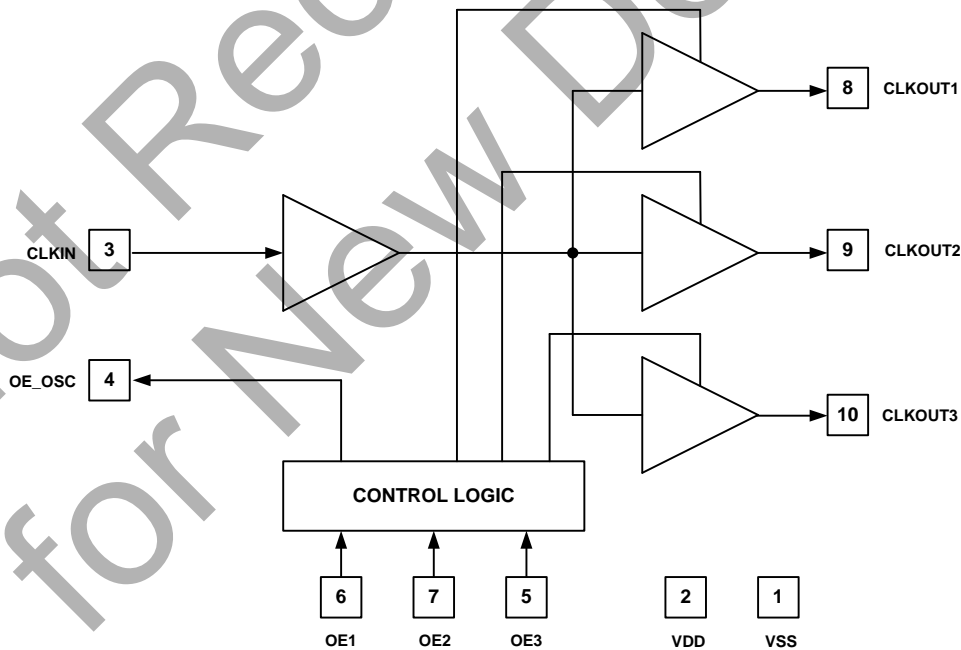

Pin Configuration

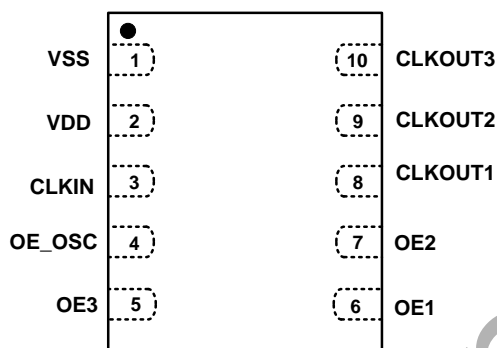

10-Pin TDFN Package Pinout

Pin Description

Pin Number	Pin Name	Pin Type	Pin Description
1	VSS	Power	Power supply ground.
2	VDD	Power	2.25 to 3.65V or 1.8V +/-5% positive power supply
3	CLKIN	Input	External clock input pin. VSS to VDD CMOS level.
4	OE_osc	Output	Crystal oscillator enable pin. If OE1=OE2=OE3=0 then OE_osc=0. OE_osc=1 for all the other OE1/2/3 logic states.
5	OE3	Input	Output enable pin for CLKOUT3. The input has 150kΩ-typ on-chip pull-down resistor.
6	OE1	Input	Output enable pin for CLKOUT1. The input has 150kΩ-typ on-chip pull-down resistor.
7	OE2	Input	Output enable pin for CLKOUT2. The input has 150kΩ-typ on-chip pull-down resistor.
8	CLKOUT1	Output	Clock output-1. Clock frequency is the same as CLKIN.
9	CLKOUT2	Output	Clock output-2. Clock frequency is the same as CLKIN.
10	CLKOUT3	Output	Clock output-3. Clock frequency is the same as CLKIN.

OE1 (Input)	OE2 (Input)	OE3 (Input)	OE_osc (Output)	CLKOUT1	CLKOUT2	CLKOUT3
0	0	0	0	Hi-Z	Hi-Z	Hi-Z
1	0	0	1	CLOCK	Hi-Z	Hi-Z
1	1	0	1	CLOCK	CLOCK	Hi-Z
...
1	1	1	1	CLOCK	CLOCK	CLOCK

Table 1. Truth Table for OE1/2/3, OE_osc and CLKOUT1/2/3

Absolute Maximum Ratings

Description	Condition	Min	Max	Unit
Supply voltage, VDD (Absolute)		-0.5	4.6	V
Supply voltage, VDD (Operation)		1.70	3.65	V
All Inputs and Outputs		-0.5	VDD+0.5	V
Ambient Operating Temperature	In operation, C-Grade	-40	85	°C
Storage Temperature	No power is applied	-65	150	°C
Junction Temperature	In operation, power is applied	-	125	°C
Soldering Temperature		-	260	°C
ESD Rating (Human Body Model)	JEDEC22-A114D	-4,000	4,000	V
ESD Rating (Charge Device Model)	JEDEC22-C101C	-1,500	1,500	V
ESD Rating (Machine Model)	JEDEC22-A115D	-200	200	V

DC Electrical Characteristics (I-Grade)

Unless otherwise stated VDD= 1.8V+/- 5% and Operation Temperature Range -40 to +85°C

Description	Symbol	Condition	Min	Typ	Max	Unit
Operating Voltage	VDD	Operation range, 1.8V+/-5%	1.70	1.80	1.90	V
Operating Temperature	TA	I-Grade	-40	25	85	°C
Input Low Voltage	VIL	CMOS Level, Pins 3,5, 6 and 7	VSS	-	0.3VDD	V
Input High Voltage	VIH	CMOS Level, Pins 3,5, 6 and 7	0.7VDD	-	VDD	V
Output High Voltage	VOH	IOH=-4mA, Pins 4, 8, 9 and 10	VDD-0.4	-	-	V
Output Low Voltage	VOL	IOL=-4mA, Pins 4, 8, 9 and 10	-	-	0.4	V
Input Leakage Current	ILH	VIN=VDD, Pins 5, 6 and 7	-25	-	25	µA
Input Leakage Current	ILL	VIN=GND, Pins 5, 6 and 7	-10	-	10	µA
Pull-Down Resistor	RPD	Pins 5, 6 and 7	100	150	250	kΩ
Operating Supply Current	IDD1	CLKIN=26MHz, OE1=OE2=OE3=1	-	2.7	-	mA
Operating Supply Current	IDD2	OE1=OE2=OE3=0 CLKIN=Low or High	-	-	1.0	µA
Input Capacitance	CIN	Pins 5, 6 and 7	-	3	5	pF
Load Capacitance	CL	CLKOUT1/2/3, Pins 8, 9 and 10	-	10	20	pF

AC Electrical Characteristics (I-Grade)

Unless otherwise stated VDD= 1.8V+/- 5% and Operation Temperature Range -40 to +85°C

Parameter	Symbol	Condition	Min	Typ	Max	Unit
Input Clock Range	CLKIN	External Clock, CMOS square wave	10	26.000	52	MHz
Output Clock Range	CLKOUT	External Clock, CMOS square wave CLKOUT1/2/3	10	26.000	52	MHz
Input Clock Voltage Swing Level	VINpp	VDD=1.8V	0.72	1	-	Vpp
Input Duty Cycle	DCIN	CLKIN, Pin 3	30	50	70	%
Output Clock Rise Time	tr	VDD=1.8, CL=10pF, measured from 10 to 90% of VDD, Pins 4, 8, 9 and 10	-	2.0	4.00	ns
Output Clock Fall Time	tf	VDD=1.8, CL=10pF, measured from 10 to 90% of VDD, Pins 4, 8, 9 and 10	-	2.0	4.00	ns
Additive Phase Noise	APN-1	CLKIN=26MHz and 1 kHz offset CLKOUT1/2/3	-	-140	-	dBc/Hz
Additive Phase Noise	APN-2	CLKIN=26MHz and 10 kHz offset CLKOUT1/2/3	-	-150	-	dBc/Hz
Additive Phase Noise	APN-3	CLKIN=26MHz and 100 kHz offset CLKOUT1/2/3	-	-159	-	dBc/Hz
Power-up Time	tPU	Time duration until CLKOUT1/2/3 frequency reaches valid frequency after power supply reaches 0.9xVDD value	-	100	200	Ns
Output Enable Time	tOE1	Time from OE raising edge to active at outputs CLKOUT1/2/3 (Asynchronous)	-	25	-	ns
Output Disable Time	tOD	Time from OE falling edge to Hi-Z at outputs CLKOUT1/2/3 (Asynchronous)	-	25	-	ns
Output Enable Time	tOE2	Active recovery time from standby (CLKIN=0 or 1) to active at outputs CLKOUT1/2/3	-	100	-	Ns

DC Electrical Characteristics (I-Grade)

Unless otherwise stated VDD= 2.5V+/- 10% and Operation Temperature Range -40 to +85°C

Description	Symbol	Condition	Min	Typ	Max	Unit
Operating Voltage	VDD	Operation range, 2.5V+/-10%	2.25	2.50	2.75	V
Operating Temperature	TA	I-Grade	-40	25	85	°C
Input Low Voltage	VIL	CMOS Level, Pins 3,5, 6 and 7	VSS	-	0.3VDD	V
Input High Voltage	VIH	CMOS Level, Pins 3,5, 6 and 7	0.7VDD	-	VDD	V
Output High Voltage	VOH	IOH=-4mA , Pins 4, 8, 9 and 10	VDD-0.4	-	-	V
Output Low Voltage	VOL	IOL=-4mA, Pins 4, 8, 9 and 10	-	-	0.4	V
Input Leakage Current	ILH	VIN=VDD, Pins 5, 6 and 7	-30	-	30	µA
Input Leakage Current	ILL	VIN=GND, Pins 5, 6 and 7	-15	-	15	µA
Pull-Down Resistor	RPD	Pins 5, 6 and 7	100	150	250	kΩ
Operating Supply Current	IDD1	CLKIN=26MHz, OE1=OE2=OE3=1	-	3.0	-	mA
Operating Supply Current	IDD2	OE1=OE2=OE3=0 CLKIN=Low or High	-	-	1.5	µA
Input Capacitance	CIN	Pins 5, 6 and 7	-	3	5	pF
Load Capacitance	CL	CLKOUT1/2/3, Pins 8, 9 and 10	-	10	20	pF

AC Electrical Characteristics (I-Grade)

Unless otherwise stated VDD= 2.5V+/- 10% and Operation Temperature Range -40 to +85°C

Parameter	Symbol	Condition	Min	Typ	Max	Unit
Input Clock Range	CLKIN	External Clock, CMOS square wave	10	26.000	52	MHz
Output Clock Range	CLKOUT	External Clock, CMOS square wave CLKOUT1/2/3	10	26.000	52	MHz
Input Clock Voltage Swing Level	VINpp	VDD=2.5V, connect to CLKIN directly	1.0	1.2	-	V
		VDD=2.5V, connect to CLKIN through AC coupling and bias circuit	0.6	-	-	V
Input Duty Cycle	DCIN	CLKIN, Pin 3	30	50	70	%
Output Clock Rise Time	tr	VDD=1.8, CL=10pF, measured from 10 to 90% of VDD, Pins 4, 8, 9 and 10	-	2.0	4.00	ns
Output Clock Fall Time	tf	VDD=1.8, CL=10pF, measured from 10 to 90% of VDD, Pins 4, 8, 9 and 10	-	2.0	4.00	ns
Additive Phase Noise	APN-1	CLKIN=26MHz and 1 kHz offset CLKOUT1/2/3	-	-142	-	dBc/Hz

Additive Phase Noise	APN-2	CLKIN=26MHz and 10 kHz offset CLKOUT1/2/3	-	-156	-	dBc/Hz
Additive Phase Noise	APN-3	CLKIN=26MHz and 100 kHz offset CLKOUT1/2/3	-	-164	-	dBc/Hz
Power-up Time	tPU	Time for CLKOUT1/2/3 frequency to reach valid frequency after power supply reaches 0.9xVDDvalue	-	100	200	ns
Output Enable Time	tOE1	Time from OE raising edge to active at outputs CLKOUT1/2/3 (Asynchronous)	-	25	-	ns
Output Disable Time	tOD	Time from OE falling edge to Hi-Z at outputs CLKOUT1/2/3 (Asynchronous)	-	25	-	ns
Output Enable Time	tOE2	Active recovery time from standby (CLKIN=0 or 1) to active at outputs CLKOUT1/2/3	-	100	-	ns

DC Electrical Characteristics (I-Grade)

Unless otherwise stated VDD= 3.3V+/- 10% and Operation Temperature Range -40 to +85°C

Description	Symbol	Condition	Min	Typ	Max	Unit
Operating Voltage	VDD	Operation range , 3.3V+/-10%	2.95	3.3	3.65	V
Operating Temperature	TA	I-Grade	-40	25	85	°C
Input Low Voltage	VIL	CMOS Level, Pins 3.5, 6 and 7	VSS	-	0.3VDD	V
Input High Voltage	VIH	CMOS Level, Pins 3.5, 6 and 7	0.7VDD	-	VDD	V
Output High Voltage	VOH	IOH=-4mA , Pins 4, 8, 9 and 10	VDD-0.4	-	-	V
Output Low Voltage	VOL	IOL=-4mA, Pins 4, 8, 9 and 10	-	-	0.5	V
Input Leakage Current	ILH	VIN=VDD, Pins 5, 6 and 7	-35	-	35	µA
Input Leakage Current	ILL	VIN=GND, Pins 5, 6 and 7	-20	-	20	µA
Pull-Down Resistor	RPD	Pins 5, 6 and 7	100	150	250	kΩ
Operating Supply Current	IDD1	CLKIN=26MHz, OE1=OE2=OE3=1	-	3.4	-	mA
Operating Supply Current	IDD2	OE1=OE2=OE3=0 CLKIN=Low or High	-	-	2.0	µA
Input Capacitance	CIN	Pins 5, 6 and 7	-	3	5	pF
Load Capacitance	CL	CLKOUT1/2/3, Pins 8, 9 and 10	-	10	25	pF

AC Electrical Characteristics (I-Grade)

Unless otherwise stated VDD= 3.3V+/- 10% and Operation Temperature Range -40 to +85°C

Parameter	Symbol	Condition	Min	Typ	Max	Unit
Input Clock Range	CLKIN	External Clock, CMOS square wave	10	26.000	52	MHz
Output Clock Range	CLKOUT	External Clock, CMOS square wave CLKOUT1/2/3	10	26.000	52	MHz
Input Clock Voltage Swing Level	VINpp	VDD=3.3V, connect to CLKIN directly	1.32	1.4	-	V
		VDD=3.3V, connect to CLKIN through AC coupling and bias circuit	0.6	-	-	V
Input Duty Cycle	DCIN	CLKIN, Pin 3	30	50	70	%
Output Clock Rise Time	tr	VDD=1.8, CL=10pF, measured from 10 to 90% of VDD, Pins 4, 8, 9 and 10	-	1.2	2.2	ns
Output Clock Fall Time	tf	VDD=1.8, CL=10pF, measured from 10 to 90% of VDD, Pins 4, 8, 9 and 10	-	1.2	2.2	ns
Additive Phase Noise	APN-1	CLKIN=26MHz and 1 kHz offset CLKOUT1/2/3	-	-138	-	dBc/Hz
Additive Phase Noise	APN-2	CLKIN=26MHz and 10 kHz offset CLKOUT1/2/3	-	-157	-	dBc/Hz
Additive Phase Noise	APN-3	CLKIN=26MHz and 100 kHz offset CLKOUT1/2/3	-	-165	-	dBc/Hz
Power-up Time	tPU	Time duration until CLKOUT1/2/3 frequency reaches valid frequency after power supply reaches 0.9xVDD value	-	100	200	ns
Output Enable Time	tOE1	Time from OE raising edge to active at outputs CLKOUT1/2/3 (Asynchronous)	-	25	-	ns
Output Disable Time	tOD	Time from OE falling edge to Hi-Z at outputs CLKOUT1/2/3 (Asynchronous)	-	25	-	ns
Output Enable Time	tOE2	Active recovery time from standby (CLKIN=0 or 1) to active at outputs CLKOUT1/2/3	-	100	-	ns

SL18860DC CLKOUT1/2/3							
Phase Noise (dBc/Hz) CL=15pF.							
VDD(V)	100hz	1Khz	10Khz	100Khz	1Mhz	5Mhz	Fig #
1.8	-115.52	-139.85	-150.79	-159.31	-160.52	-162.52	1
2.5	-125.16	-142.67	-156.37	-164.02	-166.45	-167.02	2
3.3	-116.60	-138.06	157.41	-164.88	-167.21	-168.57	3

Table 2. Output Phase Noise Summary Table

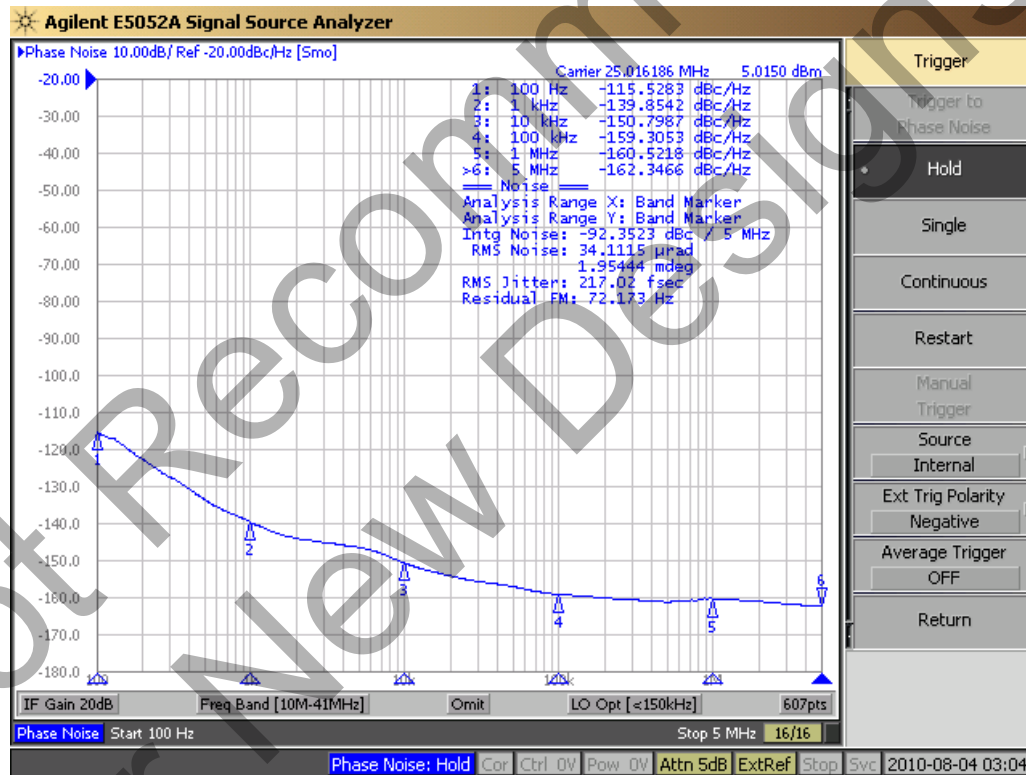

Figure 1. Output Phase Noise VDD=1.8V, CL=15pF

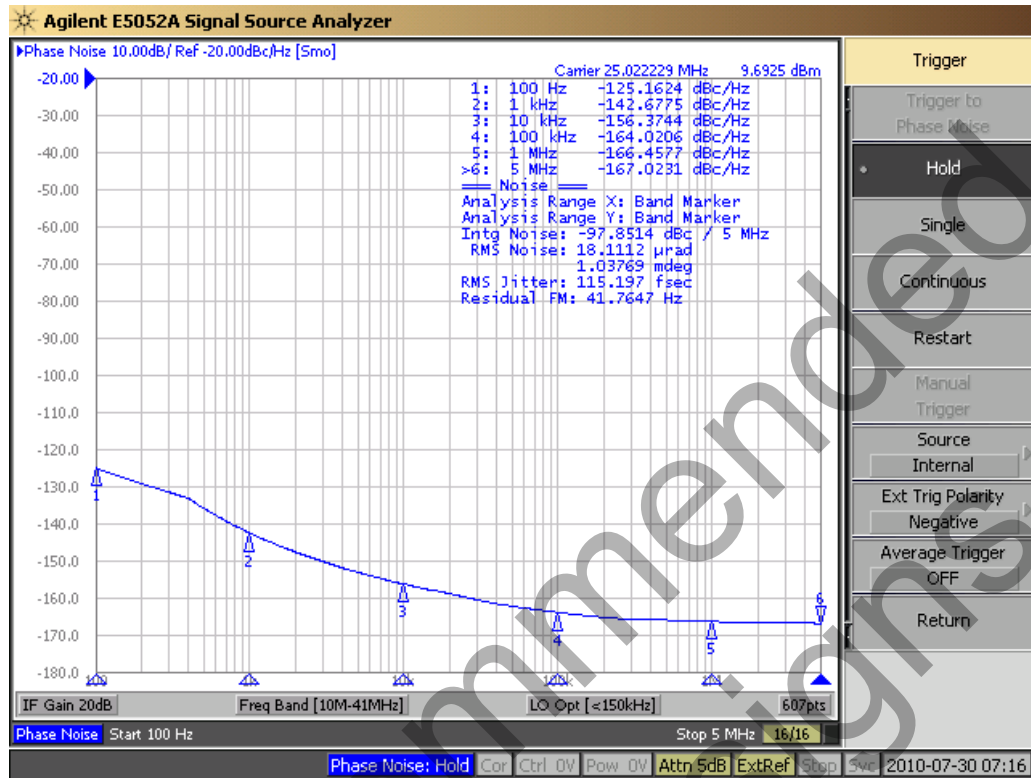

Figure 2. Output Phase Noise VDD=2.5V, CL=15pF

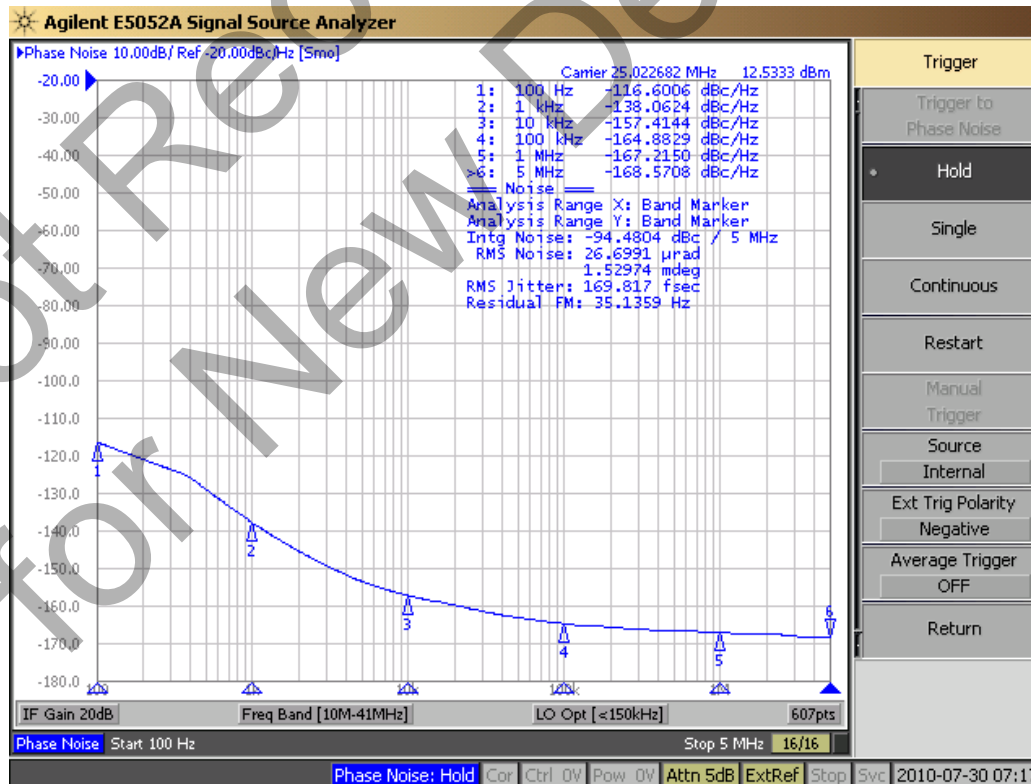
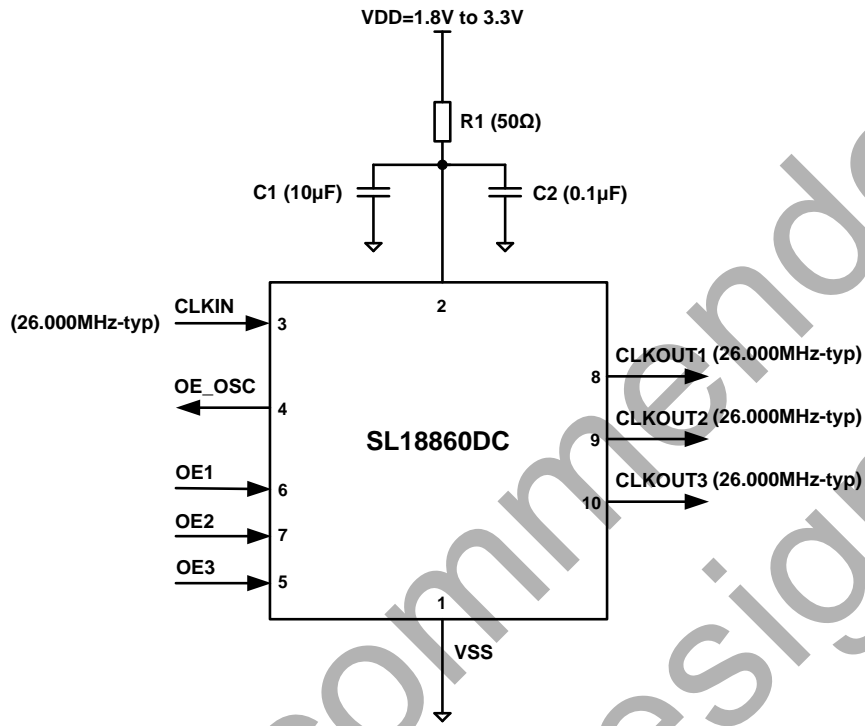
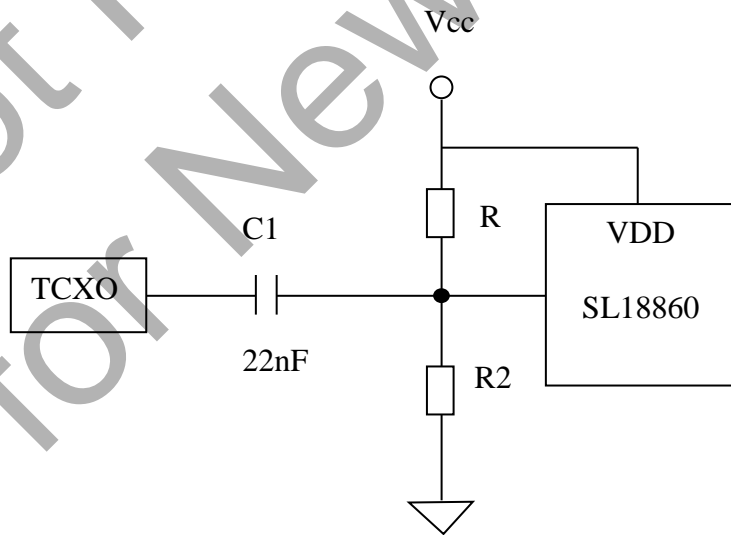

Figure 3. Output Phase Noise VDD=3.3V, CL=15pF

Typical Application Circuit



AC coupling and bias circuit



Package Outline and Package Dimensions

10-Pin TDFN Package (1.4x2.0x0.75 mm)

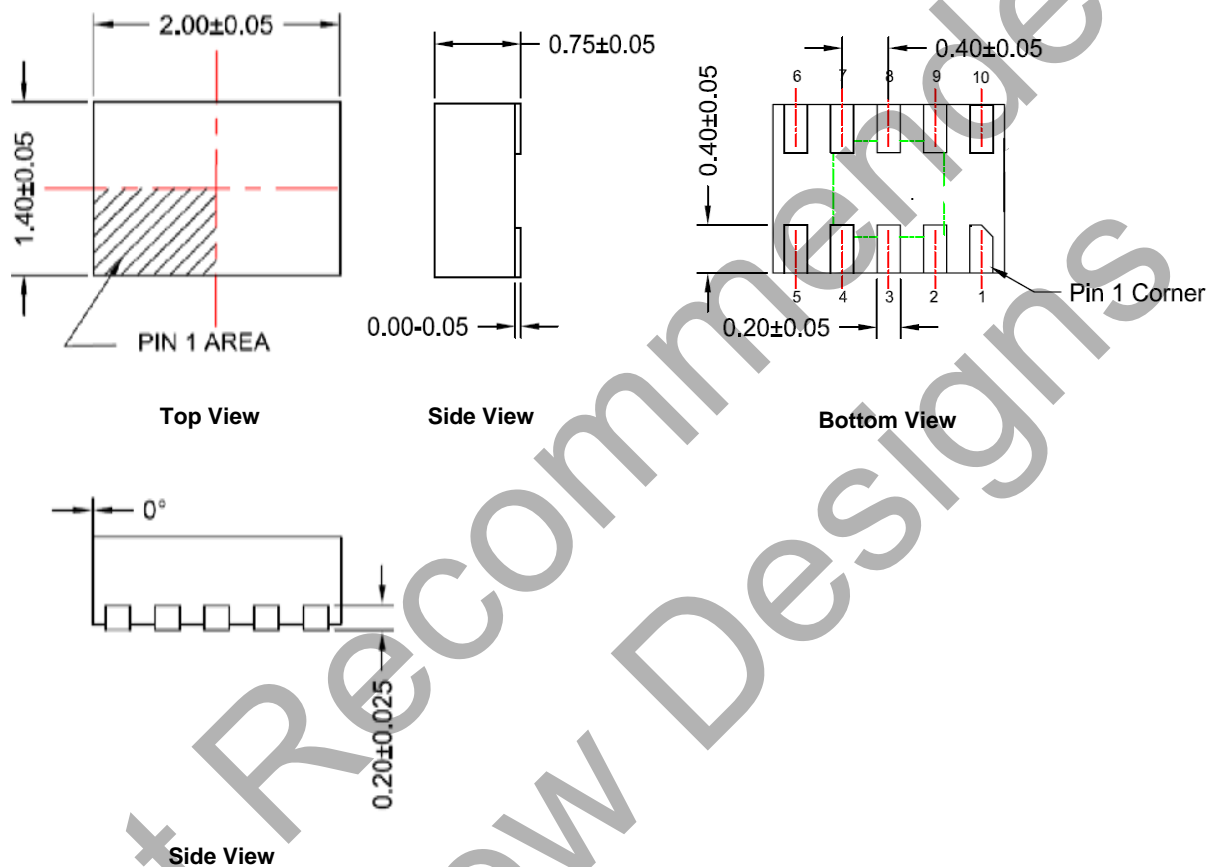

Ordering Information

Ordering Number	Shipping Package	Package	Temperature
SL18860DC	Tube	10-pin TDFN	-40 to 85°C
SL18860DCT	Tape and Reel	10-pin TDFN	-40 to 85°C

Note:

The SL18860 is RoHS compliant



Pin 1

Line	Characters	Description
1	TTTT	Manufacturing Trace Code
2	YWW	Characters corresponding to the last digit of year (Y) and work week (WW) of package assembly



ClockBuilder Pro

One-click access to Timing tools, documentation, software, source code libraries & more. Available for Windows and iOS (CBGo only).

www.silabs.com/CBPro



Timing Portfolio
www.silabs.com/timing



SW/HW
www.silabs.com/CBPro



Quality
www.silabs.com/quality



Support and Community
community.silabs.com

Disclaimer

Silicon Labs intends to provide customers with the latest, accurate, and in-depth documentation of all peripherals and modules available for system and software implementers using or intending to use the Silicon Labs products. Characterization data, available modules and peripherals, memory sizes and memory addresses refer to each specific device, and "Typical" parameters provided can and do vary in different applications. Application examples described herein are for illustrative purposes only. Silicon Labs reserves the right to make changes without further notice and limitation to product information, specifications, and descriptions herein, and does not give warranties as to the accuracy or completeness of the included information. Silicon Labs shall have no liability for the consequences of use of the information supplied herein. This document does not imply or express copyright licenses granted hereunder to design or fabricate any integrated circuits. The products are not designed or authorized to be used within any Life Support System without the specific written consent of Silicon Labs. A "Life Support System" is any product or system intended to support or sustain life and/or health, which, if it fails, can be reasonably expected to result in significant personal injury or death. Silicon Labs products are not designed or authorized for military applications. Silicon Labs products shall under no circumstances be used in weapons of mass destruction including (but not limited to) nuclear, biological or chemical weapons, or missiles capable of delivering such weapons.

Trademark Information

Silicon Laboratories Inc.®, Silicon Laboratories®, Silicon Labs®, SiLabs® and the Silicon Labs logo®, Bluegiga®, Bluegiga Logo®, Clockbuilder®, CMEMS®, DSPLL®, EFM®, EFM32®, EFR, Ember®, Energy Micro, Energy Micro logo and combinations thereof, "the world's most energy friendly microcontrollers", Ember®, EZLink®, EZRadio®, EZRadioPRO®, Gecko®, ISOModem®, Micrium, Precision32®, ProSLIC®, Simplicity Studio®, SiPHY®, Telegesis, the Telegesis Logo®, USBXpress®, Zentri and others are trademarks or registered trademarks of Silicon Labs. ARM, CORTEX, Cortex-M3 and THUMB are trademarks or registered trademarks of ARM Holdings. Keil is a registered trademark of ARM Limited. All other products or brand names mentioned herein are trademarks of their respective holders.



Silicon Laboratories Inc.
400 West Cesar Chavez
Austin, TX 78701
USA

<http://www.silabs.com>

X-ON Electronics

Largest Supplier of Electrical and Electronic Components

Click to view similar products for [Clock Buffer](#) category:

Click to view products by [Silicon Labs](#) manufacturer:

Other Similar products are found below :

[MPC962309EJ-1H](#) [NB4N121KMNG](#) [IDT49FCT805ASO](#) [MK2308S-1HILF](#) [PL133-27GI-R](#) [NB3L02FCT2G](#) [NB3L03FCT2G](#)
[ZL40203LDG1](#) [ZL40200LDG1](#) [ZL40205LDG1](#) [9FG1200DF-1LF](#) [9FG1001BGLF](#) [ZL40202LDG1](#) [PI49FCT20802QE](#) [SL2305SC-1T](#)
[PI6C4931502-04LIE](#) [NB7L1008MNG](#) [NB7L14MN1G](#) [PI49FCT20807QE](#) [PI6C4931502-04LIEX](#) [ZL80002QAB1](#) [PI6C4931504-04LIEX](#)
[PI6C10806BLEX](#) [ZL40226LDG1](#) [ZL40219LDG1](#) [8T73S208B-01NLGI](#) [SY75578LMG](#) [PI49FCT32805QEX](#) [PL133-27GC-R](#)
[CDCV304PWG4](#) [MC10LVEP11DG](#) [MC10EP11DTG](#) [MC100LVEP11DG](#) [MC100E111FNG](#) [MC100EP11DTG](#) [NB6N11SMNG](#)
[NB7L14MMNG](#) [NB3N2304NZDTR2G](#) [NB6L11MMNG](#) [NB6L14MMNR2G](#) [NB6L611MNG](#) [PL123-02NGI-R](#) [NB3N111KMNR4G](#)
[ADCLK944BCPZ-R7](#) [ZL40217LDG1](#) [NB7LQ572MNG](#) [HMC940LC4BTR](#) [ADCLK946BCPZ-REEL7](#) [ADCLK946BCPZ](#)
[ADCLK846BCPZ-REEL7](#)