

Direct Rambus™ Clock Generator

Features

- Differential clock source for Direct Rambus™ memory subsystem for up to 800-MHz data transfer rate
- Provide synchronization flexibility: the Rambus® Channel can optionally be synchronous to an external system or processor clock
- Power-managed output allows Rambus Channel clock to be turned off to minimize power consumption for mobile applications
- Works with Cypress CY2210, W133, W158, W159, W161, and W167 to support Intel® architecture platforms
- Low-power CMOS design packaged in a 24-pin QSOP (150-mil SSOP) package

Description

The Cypress W134M/W134S provides the differential clock signals for a Direct Rambus memory subsystem. It includes signals to synchronize the Direct Rambus Channel clock to an external system clock but can also be used in systems that do not require synchronization of the Rambus clock.

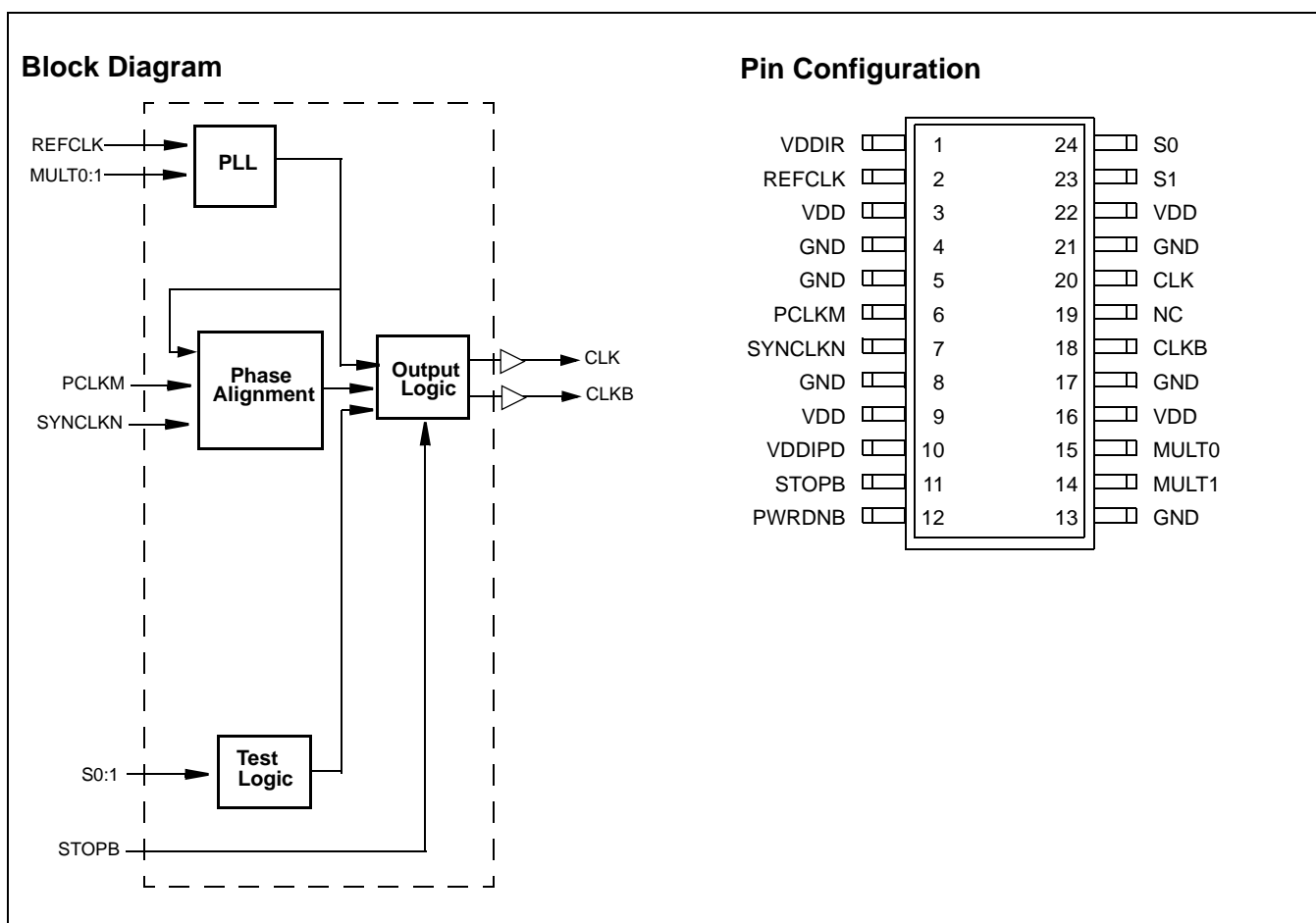

Pin Definitions

| Pin Name | No. | Type | Description | | | | | | | | | | | | | | | | | | | | | | | | |
|-----------|---------------------|--------------------|---|----|----|-------|-------|-------|--------|------------|------------|--------------------|---|-----|--------|---|---|------|---|---|---|---|---|---|---|-------|-------|
| REFCLK | 2 | I | Reference Clock Input. Reference clock input, normally supplied by a system frequency synthesizer (Cypress W133). | | | | | | | | | | | | | | | | | | | | | | | | |
| PCLKM | 6 | I | Phase Detector Input. The phase difference between this signal and SYNCLKN is used to synchronize the Rambus Channel Clock with the system clock. Both PCLKM and SYNCLKN are provided by the Gear Ratio Logic in the memory controller. If Gear Ratio Logic is not used, this pin would be connected to Ground. | | | | | | | | | | | | | | | | | | | | | | | | |
| SYNCLKN | 7 | I | Phase Detector Input. The phase difference between this signal and PCLKM is used to synchronize the Rambus Channel Clock with the system clock. Both PCLKM and SYNCLKN are provided by the Gear Ratio Logic in the memory controller. If Gear Ratio Logic is not used, this pin would be connected to Ground. | | | | | | | | | | | | | | | | | | | | | | | | |
| STOPB | 11 | I | Clock Output Enable. When this input is driven to active LOW, it disables the differential Rambus Channel clocks. | | | | | | | | | | | | | | | | | | | | | | | | |
| PWRDNB | 12 | I | Active LOW Power-down. When this input is driven to active LOW, it disables the differential Rambus Channel clocks and places the W134M/W134S in power-down mode. | | | | | | | | | | | | | | | | | | | | | | | | |
| MULT 0:1 | 15, 14 | I | PLL Multiplier Select. These inputs select the PLL prescaler and feedback dividers to determine the multiply ratio for the PLL for the input REFCLK. <table border="1" style="margin-left: auto; margin-right: auto;"> <thead> <tr> <th colspan="2"></th> <th>W134M</th> <th>W134S</th> </tr> <tr> <th>MULT0</th> <th>MULT1</th> <th>PLL/REFCLK</th> <th>PLL/REFCLK</th> </tr> </thead> <tbody> <tr> <td>0</td> <td>0</td> <td>4.5</td> <td>4</td> </tr> <tr> <td>0</td> <td>1</td> <td>6</td> <td>6</td> </tr> <tr> <td>1</td> <td>1</td> <td>8</td> <td>8</td> </tr> <tr> <td>1</td> <td>0</td> <td>5.333</td> <td>5.333</td> </tr> </tbody> </table> | | | W134M | W134S | MULT0 | MULT1 | PLL/REFCLK | PLL/REFCLK | 0 | 0 | 4.5 | 4 | 0 | 1 | 6 | 6 | 1 | 1 | 8 | 8 | 1 | 0 | 5.333 | 5.333 |
| | | W134M | W134S | | | | | | | | | | | | | | | | | | | | | | | | |
| MULT0 | MULT1 | PLL/REFCLK | PLL/REFCLK | | | | | | | | | | | | | | | | | | | | | | | | |
| 0 | 0 | 4.5 | 4 | | | | | | | | | | | | | | | | | | | | | | | | |
| 0 | 1 | 6 | 6 | | | | | | | | | | | | | | | | | | | | | | | | |
| 1 | 1 | 8 | 8 | | | | | | | | | | | | | | | | | | | | | | | | |
| 1 | 0 | 5.333 | 5.333 | | | | | | | | | | | | | | | | | | | | | | | | |
| CLK, CLKB | 20, 18 | O | Complementary Output Clock. Differential Rambus Channel clock outputs. | | | | | | | | | | | | | | | | | | | | | | | | |
| S0, S1 | 24, 23 | I | Mode Control Input. These inputs control the operating mode of the W134M/W134S. <table border="1" style="margin-left: auto; margin-right: auto;"> <thead> <tr> <th>S0</th> <th>S1</th> <th>MODE</th> </tr> </thead> <tbody> <tr> <td>0</td> <td>0</td> <td>Normal</td> </tr> <tr> <td>0</td> <td>1</td> <td>Output Enable Test</td> </tr> <tr> <td>1</td> <td>0</td> <td>Bypass</td> </tr> <tr> <td>1</td> <td>1</td> <td>Test</td> </tr> </tbody> </table> | S0 | S1 | MODE | 0 | 0 | Normal | 0 | 1 | Output Enable Test | 1 | 0 | Bypass | 1 | 1 | Test | | | | | | | | | |
| S0 | S1 | MODE | | | | | | | | | | | | | | | | | | | | | | | | | |
| 0 | 0 | Normal | | | | | | | | | | | | | | | | | | | | | | | | | |
| 0 | 1 | Output Enable Test | | | | | | | | | | | | | | | | | | | | | | | | | |
| 1 | 0 | Bypass | | | | | | | | | | | | | | | | | | | | | | | | | |
| 1 | 1 | Test | | | | | | | | | | | | | | | | | | | | | | | | | |
| NC | 19 | - | No Connect | | | | | | | | | | | | | | | | | | | | | | | | |
| VDDIR | 1 | RefV | Reference for REFCLK. Voltage reference for input reference clock. | | | | | | | | | | | | | | | | | | | | | | | | |
| VDDIPD | 10 | RefV | Reference for Phase Detector. Voltage reference for phase detector inputs and StopB. | | | | | | | | | | | | | | | | | | | | | | | | |
| VDD | 3, 9, 16, 22 | P | Power Connection. Power supply for core logic and output buffers. Connected to 3.3V supply. | | | | | | | | | | | | | | | | | | | | | | | | |
| GND | 4, 5, 8, 13, 17, 21 | G | Ground Connection. Connect all ground pins to the common system ground plane. | | | | | | | | | | | | | | | | | | | | | | | | |

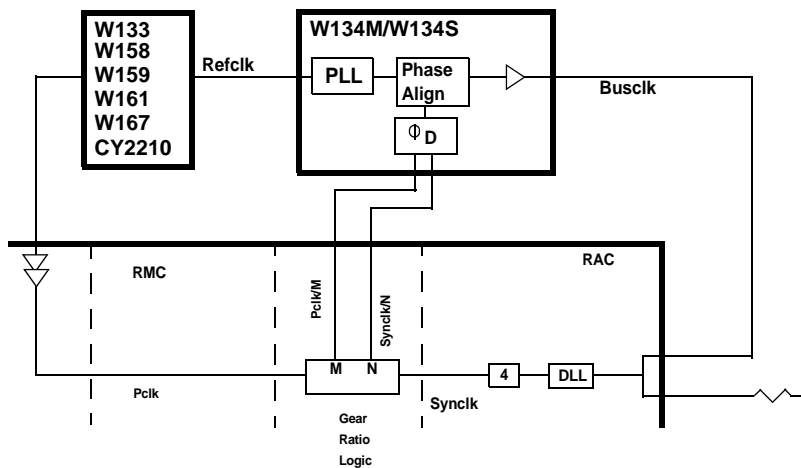

Figure 1. DDLL System Architecture

Key Specifications

Supply Voltage:..... $V_{DD} = 3.3V \pm 0.165V$
 Operating Temperature: $0^{\circ}C$ to $+70^{\circ}C$
 Input Threshold:..... 1.5V typical
 Maximum Input Voltage: $V_{DD} + 0.5V$
 Maximum Input Frequency: 100 MHz
 Output Duty Cycle:..... 40/60% worst case
 Output Type: Rambus signaling level (RSL)

DDLL System Architecture and Gear Ratio Logic

Figure 1 shows the Distributed Delay Lock Loop (DDLL) system architecture, including the main system clock source, the Direct Rambus clock generator (DRCG), and the core logic that contains the Rambus Access Cell (RAC), the Rambus Memory Controller (RMC), and the Gear Ratio Logic. (This diagram abstractly represents the differential clocks as a single Busclk wire.)

The purpose of the DDLL is to frequency-lock and phase-align the core logic and Rambus clocks (Pclk and Syncclk) at the RMC/RAC boundary in order to allow data transfers without incurring additional latency. In the DDLL architecture, a PLL is used to generate the desired Busclk frequency, while a distributed loop forms a DLL to align the phase of Pclk and Syncclk at the RMC/RAC boundary.

The main clock source drives the system clock (Pclk) to the core logic, and also drives the reference clock (Refclk) to the DRCG. For typical Intel architecture platforms, Refclk will be half the CPU front side bus frequency. A PLL inside the DRCG multiplies Refclk to generate the desired frequency for Busclk, and Busclk is driven through a terminated transmission line

(Rambus Channel). At the mid-point of the channel, the RAC senses Busclk using its own DLL for clock alignment, followed by a fixed divide-by-4 that generates Syncclk.

Pclk is the clock used in the memory controller (RMC) in the core logic, and Syncclk is the clock used at the core logic interface of the RAC. The DDLL together with the Gear Ratio Logic enables users to exchange data directly from the Pclk domain to the Syncclk domain without incurring additional latency for synchronization. In general, Pclk and Syncclk can be of different frequencies, so the Gear Ratio Logic must select the appropriate M and N dividers such that the frequencies of Pclk/M and Syncclk/N are equal. In one interesting example, Pclk = 133 MHz, Syncclk = 100 MHz, and M = 4 while N = 3, giving Pclk/M = Syncclk/N = 33 MHz. This example of the clock waveforms with the Gear Ratio Logic is shown in Figure 2.

The output clocks from the Gear Ratio Logic, Pclk/M, and Syncclk/N, are output from the core logic and routed to the DRCG Phase Detector inputs. The routing of Pclk/M and Syncclk/N must be matched in the core logic as well as on the board.

After comparing the phase of Pclk/M vs. Syncclk/N, the DRCG Phase Detector drives a phase aligner that adjusts the phase of the DRCG output clock, Busclk. Since everything else in the distributed loop is fixed delay, adjusting Busclk adjusts the phase of Syncclk and thus the phase of Syncclk/N. In this manner the distributed loop adjusts the phase of Syncclk/N to match that of Pclk/M, nulling the phase error at the input of the DRCG Phase Detector. When the clocks are aligned, data can be exchanged directly from the Pclk domain to the Syncclk domain.

Table 1 shows the combinations of Pclk and Busclk frequencies of greatest interest, organized by Gear Ratio.

Table 1. Supported Pclk and Busclk Frequencies, by Gear Ratio

| Pclk | Gear Ratio and Busclk | | | |
|---------|-----------------------|---------|---------|---------|
| | 2.0 | 1.5 | 1.33 | 1.0 |
| 67 MHz | | | | 267 MHz |
| 100 MHz | | | 300 MHz | 400 MHz |
| 133 MHz | 267 MHz | 356 MHz | 400 MHz | |
| 150 MHz | | 400 MHz | | |
| 200 MHz | 400 MHz | | | |

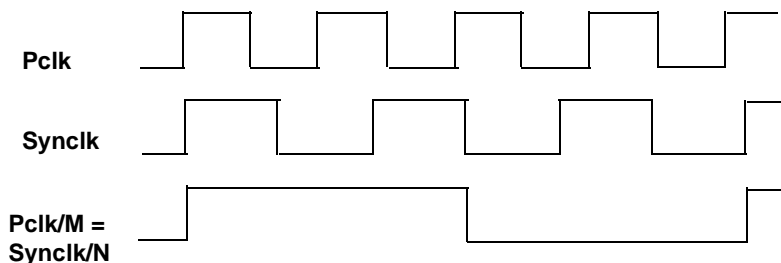

Figure 2. Gear Ratio Timing Diagram

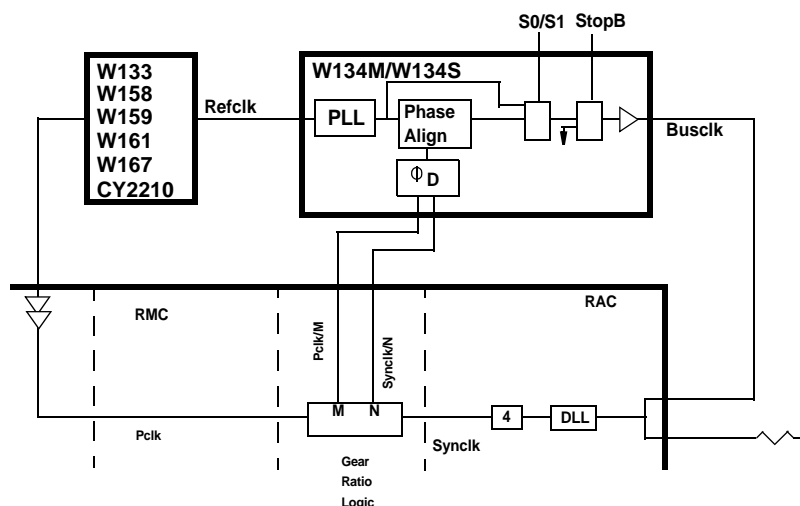

Figure 3. DDLL Including Details of DRCG

Figure 3 shows more details of the DDLL system architecture, including the DRCG output enable and bypass modes.

Phase Detector Signals

The DRCG Phase Detector receives two inputs from the core logic, PclkM (Pclk/M) and SynclkN (Synclk/N). The M and N dividers in the core logic are chosen so that the frequencies of PclkM and SynclkN are identical. The Phase Detector detects the phase difference between the two input clocks, and drives the DRCG Phase Aligner to null the input phase error through the distributed loop. When the loop is locked, the input phase error between PclkM and SynclkN is within the specification $t_{ERR,PD}$ given in the Device Characteristics table after the lock time given in the State Transition Section.

The Phase Detector aligns the rising edge of PclkM to the rising edge of SynclkN. The duty cycle of the phase detector input clocks will be within the specification $DC_{IN,PD}$ given in the Operating Conditions table. Because the duty cycles of the two phase detector input clocks will not necessarily be identical, the falling edges of PclkM and SynclkN may not be aligned when the rising edges are aligned.

The voltage levels of the PclkM and SynclkN signals are determined by the controller. The pin VDDIPD is used as the voltage reference for the phase detector inputs and should be connected to the output voltage supply of the controller. In some applications, the DRCG PLL output clock will be used directly, by bypassing the Phase Aligner. If PclkM and SynclkN are not used, those inputs must be grounded.

Selection Logic

Table 2 shows the logic for selecting the PLL prescaler and feedback dividers to determine the multiply ratio for the PLL from the input Refclk. Divider A sets the feedback and divider B sets the prescaler, so the PLL output clock frequency is set by: $PLL_{clk} = Refclk * A/B$.

Table 2. PLL Divider Selection

| Mult0 | Mult1 | W134M | | W134S | |
|-------|-------|-------|---|-------|---|
| | | A | B | A | B |
| 0 | 0 | 9 | 2 | 4 | 1 |
| 0 | 1 | 6 | 1 | 6 | 1 |
| 1 | 1 | 8 | 1 | 8 | 1 |
| 1 | 0 | 16 | 3 | 16 | 3 |

Table 3 shows the logic for enabling the clock outputs, using the StopB input signal. When StopB is HIGH, the DRCG is in its normal mode, and Clk and ClkB are complementary outputs following the Phase Aligner output (PAclk). When StopB is LOW, the DRCG is in the Clk Stop mode, the output clock drivers are disabled (set to Hi-Z), and the Clk and ClkB settle to the DC voltage $V_{X,STOP}$ as given in the Device Characteristics table. The level of $V_{X,STOP}$ is set by an external resistor network.

Table 3. Clock Stop Mode Selection

| Mode | StopB | Clk | ClkB |
|----------|-------|--------------|--------------|
| Normal | 1 | PAclk | PAclkB |
| Clk Stop | 0 | $V_{X,STOP}$ | $V_{X,STOP}$ |

Table 4 shows the logic for selecting the Bypass and Test modes. The select bits, S0 and S1, control the selection of these modes. The Bypass mode brings out the full-speed PLL output clock, bypassing the Phase Aligner. The Test mode brings the Refclk input all the way to the output, bypassing both the PLL and the Phase Aligner. In the Output Test mode (OE), both the Clk and ClkB outputs are put into a high-impedance state (Hi-Z). This can be used for component testing and for board-level testing.

Table 4. Bypass and Test Mode Selection

| Mode | S0 | S1 | Bypclk (int.) | Clk | ClkB |
|------------------|----|----|---------------|--------|---------|
| Normal | 0 | 0 | Gnd | PAclk | PAclkB |
| Output Test (OE) | 0 | 1 | – | Hi-Z | Hi-Z |
| Bypass | 1 | 0 | PLLclk | PLLclk | PLLclkB |
| Test | 1 | 1 | Refclk | Refclk | RefclkB |

Table 5 shows the logic for selecting the Power-down mode, using the PwrDnB input signal. PwrDnB is active LOW (enabled when 0). When PwrDnB is disabled, the DRCG is in its normal mode. When PwrDnB is enabled, the DRCG is put into a powered-off state, and the Clk and ClkB outputs are three-stated.

Table 5. Power-down Mode Selection

| Mode | PwrDnB | Clk | ClkB |
|------------|--------|-------|--------|
| Normal | 1 | PAclk | PAclkB |
| Power-down | 0 | GND | GND |

Table of Frequencies and Gear Ratios

Table 6 shows several supported Pclk and Busclk frequencies, the corresponding A and B dividers required in the DRCG PLL, and the corresponding M and N dividers in the gear ratio logic. The column Ratio gives the Gear Ratio as defined Pclk/Synclk (same as M and N). The column F@PD gives the divided down frequency (in MHz) at the Phase Detector, where $F@PD = Pclk/M = Synclk/N$.

State Transitions

The clock source has three fundamental operating states. Figure 4 shows the state diagram with each transition labelled A through H. Note that the clock source output may NOT be glitch-free during state transitions.

Upon powering up the device, the device can enter any state, depending on the settings of the control signals, PwrDnB and StopB.

In Power-down mode, the clock source is powered down with the control signal, PwrDnB, equal to 0. The control signals S0

and S1 must be stable before power is applied to the device, and can only be changed in Power-down mode (PwrDnB = 0). The reference inputs, V_{DDR} and V_{DDPD}, may remain on or may be grounded during the Power-down mode.

Table 6. Examples of Frequencies, Dividers, and Gear Ratios

| Pclk | Refclk | Busclk | Synclk | A | B | M | N | Ratio | F@PD |
|------|--------|--------|--------|---|---|---|---|-------|------|
| 67 | 33 | 267 | 67 | 8 | 1 | 2 | 2 | 1.0 | 33 |
| 100 | 50 | 300 | 75 | 6 | 1 | 8 | 6 | 1.33 | 12.5 |
| 100 | 50 | 400 | 100 | 8 | 1 | 4 | 4 | 1.0 | 25 |
| 133 | 67 | 267 | 67 | 4 | 1 | 4 | 2 | 2.0 | 33 |
| 133 | 67 | 400 | 100 | 6 | 1 | 8 | 6 | 1.33 | 16.7 |

The control signals Mult0 and Mult1 can be used in two ways. If they are changed during Power-down mode, then the Power-down transition timings determine the settling time of the DRCG. However, the Mult0 and Mult1 control signals can also be changed during Normal mode. When the Mult control signals are “hot-swapped” in this manner, the Mult transition timings determine the settling time of the DRCG.

In Normal mode, the clock source is on, and the output is enabled.

Table 7 lists the control signals for each state.

Table 7. Control Signals for Clock Source States

| State | PwrDnB | StopB | Clock Source | Output Buffer |
|------------|--------|-------|--------------|---------------|
| Power-down | 0 | X | OFF | Ground |
| Clock Stop | 1 | 0 | ON | Disabled |
| Normal | 1 | 1 | ON | Enabled |

Figure 5 shows the timing diagrams for the various transitions between states, and Table 8 specifies the latencies of each state transition. Note that these transition latencies assume the following.

Refclk input has settled and meets specification shown in the Operating Conditions table.

The Mult0, Mult1, S0 and S1 control signals are stable.

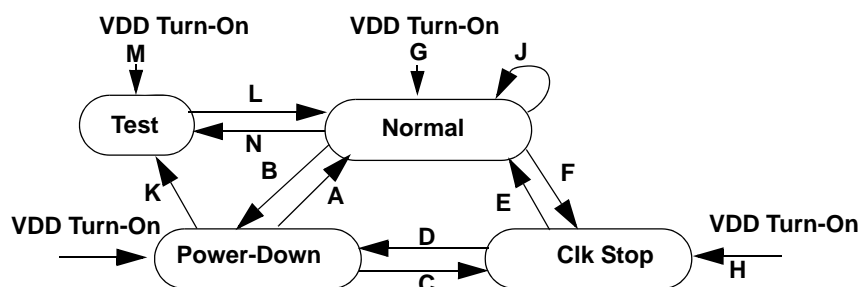
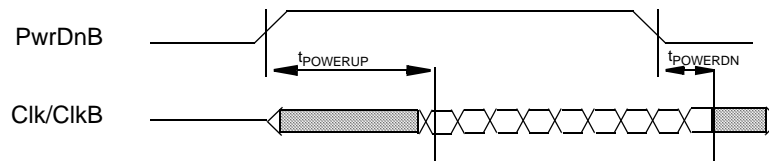

Figure 4. Clock Source State Diagram

Timing Diagrams

Power-down Exit and Entry



Output Enable Control

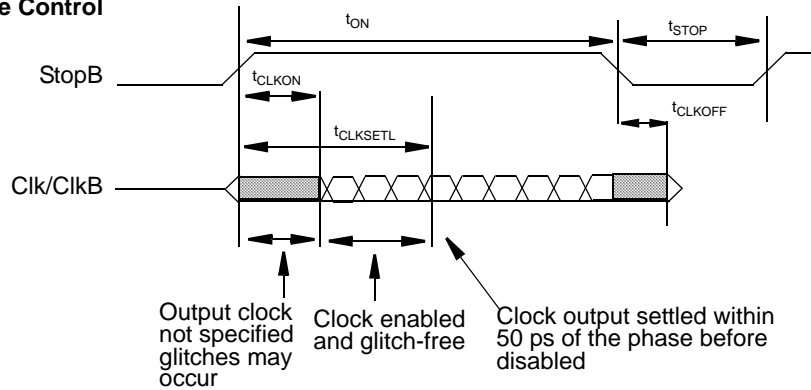

Figure 5. State Transition Timing Diagrams

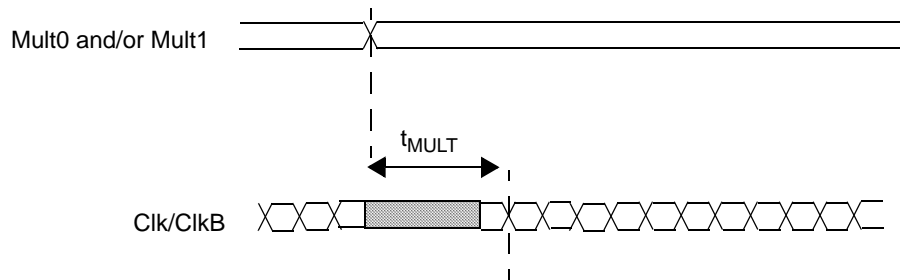

Figure 6. Multiply Transition Timing

Table 8. State Transition Latency Specifications

| Transition | From | To | Transition Latency | | Description |
|------------|-------------|----------|--------------------|------|--|
| | | | Parameter | Max. | |
| A | Power-down | Normal | $t_{POWERUP}$ | 3 ms | Time from PwrDnB to Clk/ClkB output settled (excluding $t_{DISTLOCK}$). |
| C | Power-down | Clk Stop | $t_{POWERUP}$ | 3 ms | Time from PwrDnB until the internal PLL and clock has turned ON and settled. |
| K | Power-down | Test | $t_{POWERUP}$ | 3 ms | Time from PwrDnB to Clk/ClkB output settled (excluding $t_{DISTLOCK}$). |
| G | V_{DD} ON | Normal | $t_{POWERUP}$ | 3 ms | Time from V_{DD} is applied and settled until Clk/ClkB output settled (excluding $t_{DISTLOCK}$). |
| H | V_{DD} ON | Clk Stop | $t_{POWERUP}$ | 3 ms | Time from V_{DD} is applied and settled until internal PLL and clock has turned ON and settled. |
| M | V_{DD} ON | Test | $t_{POWERUP}$ | 3 ms | Time from V_{DD} is applied and settled until internal PLL and clock has turned ON and settled. |
| J | Normal | Normal | t_{MULT} | 1 ms | Time from when Mult0 or Mult1 changed until Clk/ClkB output resettled (excluding $t_{DISTLOCK}$). |

Table 8. State Transition Latency Specifications (continued)

| Transition | From | To | Transition Latency | | Description |
|------------|--------------------|------------|--------------------|-----------|---|
| | | | Parameter | Max. | |
| E | Clk Stop | Normal | t_{CLKON} | 10 ns | Time from StopB until Clk/ClkB provides glitch-free clock edges. |
| E | Clk Stop | Normal | $t_{CLKSETL}$ | 20 cycles | Time from StopB to Clk/ClkB output settled to within 50 ps of the phase before CLK/CLKB was disabled. |
| F | Normal | Clk Stop | t_{CLKOFF} | 5 ns | Time from StopB to Clk/ClkB output disabled. |
| L | Test | Normal | t_{CTL} | 3 ms | Time from when S0 or S1 is changed until CLK/CLKB output has resettled (excluding $t_{DISTLOCK}$). |
| N | Normal | Test | t_{CTL} | 3 ms | Time from when S0 or S1 is changed until CLK/CLKB output has resettled (excluding $t_{DISTLOCK}$). |
| B,D | Normal or Clk Stop | Power-down | $t_{POWERDN}$ | 1 ms | Time from PwrDnB to the device in Power-down. |

Figure 5 shows that the Clk Stop to Normal transition goes through three phases. During t_{CLKON} , the clock output is not specified and can have glitches. For $t_{CLKON} < t < t_{CLKSETL}$, the clock output is enabled and must be glitch-free. For $t > t_{CLKSETL}$, the clock output phase must be settled to within 50 ps of the phase before the clock output was disabled. At this time, the clock output must also meet the voltage and timing specifications of the Device Characteristics table. The outputs are in a high-impedance state during the Clk Stop mode.

Table 9. Distributed Loop Lock Time Specification

| Parameter | Description | Min. | Max. | Unit |
|----------------|--|------|------|------|
| $t_{DISTLOCK}$ | Time from when Clk/ClkB output is settled to when the phase error between SyncIn and PclkM falls within the $t_{ERR,PD}$ spec in Table . | | 5 | ms |

Table 10. Supply and Reference Current Specification

| Parameter | Description | Min. | Max. | Unit |
|-----------------|---|------|------|---------|
| $I_{POWERDOWN}$ | “Supply” current in Power-down state (PwrDnB = 0) | – | 250 | μA |
| $I_{CLKSTOP}$ | “Supply” current in Clk Stop state (StopB = 0) | – | 65 | mA |
| I_{NORMAL} | “Supply” current in Normal state (StopB = 1, PwrDnB = 1) | – | 100 | mA |
| $I_{REF,PWDN}$ | Current at VDDIR or VDDIPD reference pin in Power-down state (PwrDnB = 0) | – | 50 | μA |
| $I_{REF,NORM}$ | Current at VDDIR or VDDIPD reference pin in Normal or Clk Stop state (PwrDnB = 1) | – | 2 | mA |

Absolute Maximum Conditions^[1]

| Parameter | Description | Min. | Max. | Unit |
|----------------------|--|------|-----------------------|------|
| V _{DD, ABS} | Max. voltage on V _{DD} with respect to ground | -0.5 | 4.0 | V |
| V _{I, ABS} | Max. voltage on any pin with respect ground | -0.5 | V _{DD} + 0.5 | V |

External Component Values^[2]

| Parameter | Description | Min. | Max. | Unit |
|------------------|----------------------------|---------------------|--------|------|
| R _S | Serial Resistor | 39 | ±5% | Ω |
| R _P | Parallel Resistor | 51 | ±5% | Ω |
| C _F | Edge Rate Filter Capacitor | 4-15 ^[3] | ±10% | pF |
| C _{MID} | AC Ground Capacitor | 470 pF | 0.1 μF | ±20% |

Operating Conditions^[4]

| Parameter | Description | Min. | Max. | Unit |
|---------------------------------|---|-------|--------------------|-----------------------|
| V _{DD} | Supply Voltage | 3.135 | 3.465 | V |
| T _A | Ambient Operating Temperature | 0 | 70 | °C |
| t _{CYCLE,IN} | Refclk Input Cycle Time | 10 | 40 | ns |
| t _{J,IN} | Input Cycle-to-Cycle Jitter ^[5] | - | 250 | ps |
| DC _{IN} | Input Duty Cycle over 10,000 Cycles | 40 | 60 | %t _{CYCLE} |
| FM _{IN} | Input Frequency of Modulation | 30 | 33 | kHz |
| PM _{IN} ^[6] | Modulation Index for Triangular Modulation | - | 0.6 | % |
| | Modulation Index for Non-Triangular Modulation | - | 0.5 ^[8] | % |
| t _{CYCLE,PD} | Phase Detector Input Cycle Time at PclkM & SynclkN | 30 | 100 | ns |
| t _{ERR,INIT} | Initial Phase error at Phase Detector Inputs | -0.5 | 0.5 | t _{CYCLE,PD} |
| DC _{IN,PD} | Phase Detector Input Duty Cycle over 10,000 Cycles | 25 | 75 | t _{CYCLE,PD} |
| t _{I,SR} | Input Slew Rate (measured at 20%-80% of input voltage) for PclkM, SynclkN, and Refclk | 1 | 4 | V/ns |
| C _{IN,PD} | Input Capacitance at PclkM, SynclkN, and Refclk ^[7] | - | 7 | pF |
| DC _{IN,PD} | Input Capacitance matching at PclkM and SynclkN ^[7] | - | 0.5 | pF |
| C _{IN,CMOS} | Input Capacitance at CMOS pins (excluding PclkM, SynclkN, and Refclk) ^[7] | - | 10 | pF |
| V _{IL} | Input (CMOS) Signal Low Voltage | - | 0.3 | V _{DD} |
| V _{IH} | Input (CMOS) Signal High Voltage | 0.7 | - | V _{DD} |
| V _{IL,R} | Refclk input Low Voltage | - | 0.3 | V _{DDIR} |
| V _{IH,R} | Refclk input High Voltage | 0.7 | - | V _{DDIR} |
| V _{IL,PD} | Input Signal Low Voltage for PD Inputs and StopB | - | 0.3 | V _{DDIPD} |
| V _{IH,PD} | Input Signal High Voltage for PD Inputs and StopB | 0.7 | - | V _{DDIPD} |
| V _{DDIR} | Input Supply Reference for Refclk | 1.235 | 3.465 | V |
| V _{DDIPD} | Input Supply Reference for PD Inputs | 1.235 | 2.625 | V |

Notes:

1. Represents stress ratings only, and functional operation at the maximums is not guaranteed.
2. Gives the nominal values of the external components and their maximum acceptable tolerance, assuming Z_{CH} = 28Ω.
3. Do not populate C_F. Leave pads for future use.
4. Multiple Supplies: The voltage on any input or I/O pin cannot exceed the power pin during power-up. Power supply sequencing is NOT required.
5. Refclk jitter measured at V_{DDIR} (nom)/2.
6. If input modulation is used: input modulation is allowed but not required.
7. Capacitance measured at Freq=1 MHz, DC bias = 0.9V and V_{AC} < 100 mV.
8. The amount of allowed spreading for any non-triangular modulation is determined by the induced downstream tracking skew, which cannot exceed the skew generated by the specified 0.6% triangular modulation. Typically, the amount of allowed non-triangular modulation is about 0.5%.

Device Characteristics

| Parameter | Description | Min. | Max. | Unit |
|------------------------------|---|------|------|----------------------|
| t_{CYCLE} | Clock Cycle Time | 2.5 | 3.75 | ns |
| t_{J} | Cycle-to-Cycle Jitter at Clk/ClkB ^[9] | – | 60 | ps |
| | Total Jitter over 2, 3, or 4 Clock Cycles ^[9] | – | 100 | ps |
| | 266-MHz Cycle-to-Cycle Jitter ^[10] | – | 100 | ps |
| | 266-MHz Total Jitter over 2, 3, or 4 Clock Cycles ^[10] | – | 160 | ps |
| t_{STEP} | Phase Aligner Phase Step Size (at Clk/ClkB) | 1 | – | ps |
| $t_{\text{ERR,PD}}$ | Phase Detector Phase Error for Distributed Loop Measured at PclkM-SyncclkN (rising edges) (does not include clock jitter) | –100 | 100 | ps |
| $t_{\text{ERR,SSC}}$ | PLL Output Phase Error when Tracking SSC | –100 | 100 | ps |
| $V_{\text{X,STOP}}$ | Output Voltage during Clk Stop (StopB=0) | 1.1 | 2.0 | V |
| V_{X} | Differential Output Crossing-Point Voltage | 1.3 | 1.8 | V |
| V_{COS} | Output Voltage Swing (p-p single-ended) ^[11] | 0.4 | 0.6 | V |
| V_{OH} | Output High Voltage | – | 2.0 | V |
| V_{OL} | Output Low voltage | 1.0 | – | V |
| r_{OUT} | Output Dynamic Resistance (at pins) ^[12] | 12 | 50 | Ω |
| I_{OZ} | Output Current during Hi-Z (S0 = 0, S1 = 1) | – | 50 | μA |
| $I_{\text{OZ,STOP}}$ | Output Current during Clk Stop (StopB = 0) | – | 500 | μA |
| DC | Output Duty Cycle over 10,000 Cycles | 40 | 60 | % t_{CYCLE} |
| $t_{\text{DC,ERR}}$ | Output Cycle-to-Cycle Duty Cycle Error | – | 50 | ps |
| $t_{\text{R}}, t_{\text{F}}$ | Output Rise and Fall Times (measured at 20%–80% of output voltage) | 250 | 500 | ps |
| $t_{\text{CR,CF}}$ | Difference between Output Rise and Fall Times on the Same Pin of a Single Device (20%–80%) | – | 100 | ps |

Notes:

- 9. Output Jitter spec measured at $t_{\text{CYCLE}} = 2.5$ ns.
- 10. Output Jitter Spec measured at $t_{\text{CYCLE}} = 3.75$ ns.
- 11. $V_{\text{COS}} = V_{\text{OH}} - V_{\text{OL}}$.
- 12. $r_{\text{OUT}} = DV_{\text{O}} / D I_{\text{O}}$. This is defined at the output pins.

Layout Example

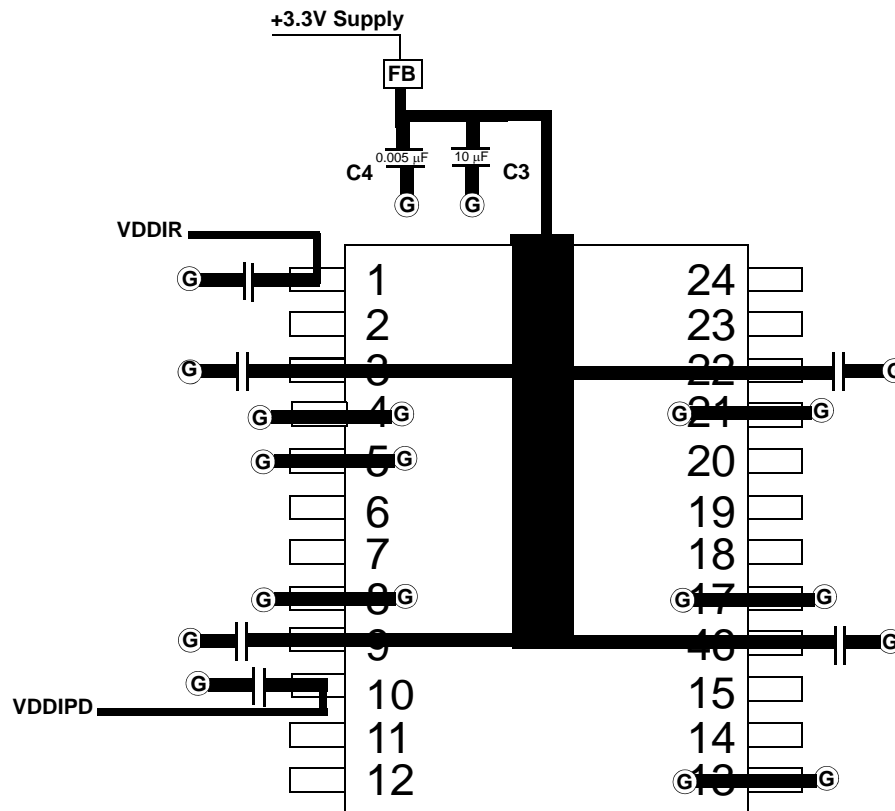

Internal Power Supply Plane

FB = Dale ILB1206 - 300 (300Ω @ 100 MHz)

Ⓞ = VIA to GND plane layer

All Bypass cap = 0.1 Ceramic XR7

Ordering Information

| Ordering Code | Package Type |
|------------------|--|
| W134H | 24-pin QSOP (150 mils, SSOP) |
| W134HT | 24-pin QSOP (150 mils, SSOP) – Tape and Reel |
| W134SH | 24-pin QSOP (150 mils, SSOP) |
| W134SHT | 24-pin QSOP (150 mils, SSOP) – Tape and Reel |
| Lead-free | |
| CYW134MOXC | 24-pin QSOP (150 mils, SSOP) |
| CYW134MOXCT | 24-pin QSOP (150 mils, SSOP), Tape and Reel |
| CYW134SOXC | 24-pin QSOP (150 mils, SSOP) |
| CYW134SOXCT | 24-pin QSOP (150 mils, SSOP), Tape and Reel |

Package Diagram

24-Lead Quarter Size Outline Q13

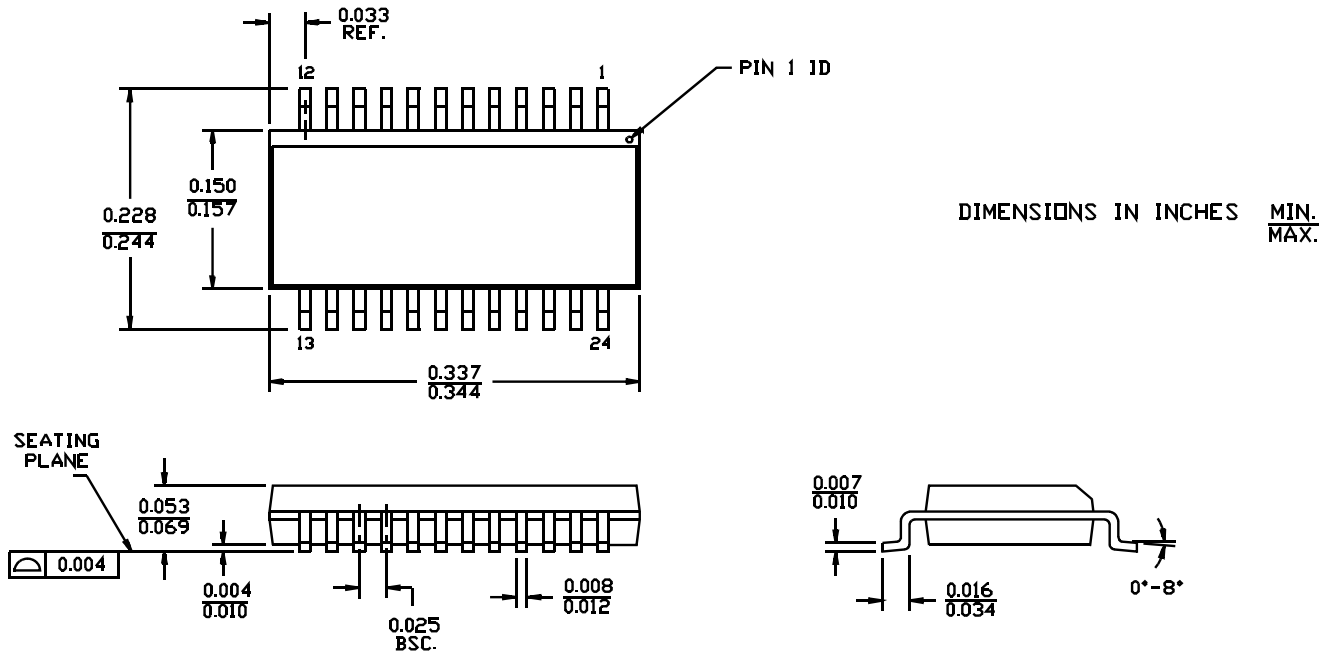

The information in this document is believed to be accurate in all respects at the time of publication but is subject to change without notice. Silicon Laboratories assumes no responsibility for errors and omissions, and disclaims responsibility for any consequences resulting from the use of information included herein. Additionally, Silicon Laboratories assumes no responsibility for the functioning of undescribed features or parameters. Silicon Laboratories reserves the right to make changes without further notice. Silicon Laboratories makes no warranty, representation or guarantee regarding the suitability of its products for any particular purpose, nor does Silicon Laboratories assume any liability arising out of the application or use of any product or circuit, and specifically disclaims any and all liability, including without limitation consequential or incidental damages. Silicon Laboratories products are not designed, intended, or authorized for use in applications intended to support or sustain life, or for any other application in which the failure of the Silicon Laboratories product could create a situation where personal injury or death may occur. Should Buyer purchase or use Silicon Laboratories products for any such unintended or unauthorized application, Buyer shall indemnify and hold Silicon Laboratories harmless against all claims and damages.

X-ON Electronics

Largest Supplier of Electrical and Electronic Components

Click to view similar products for [Clock Generators & Support Products](#) category:

Click to view products by [Silicon Labs](#) manufacturer:

Other Similar products are found below :

[5P49V5901A748NLGI](#) [5P49V5901B680NLGI](#) [5P49V5901B744NLGI](#) [5P49V5929B502NLGI](#) [5P49V5935B520LTGI](#) [5V49EE903-116NLGI](#)
[CV183-2TPAG](#) [82P33814ANLG/W](#) [8T49N004A-002NLGI](#) [8T49N004A-039NLGI](#) [9FGV0631CKLF](#) [9FGV0641AKLFT](#) [9LRS3197AKLF](#)
[9UMS9633BFILF](#) [9VRS4450AKLF](#) [NB3N51132DTR2G](#) [8N3Q001EG-0035CDI](#) [932SQ426AKLF](#) [950810CGLF](#) [9DBV0531AKILF](#)
[9DBV0741AKILF](#) [9FGV0641AKLF](#) [9UMS9633BKLF](#) [9VRS4420DKILF](#) [9VRS4420DKLF](#) [9VRS4420DKLFT](#) [CY25404ZXI226](#)
[CY25422SXI-004](#) [5P49V5901B712NLGI](#) [NB3H5150-01MNTXG](#) [6INT61041NDG](#) [PL602-20-K52TC](#) [PL613-51QC](#) [8N3Q001FG-1114CDI](#)
[9FGV0641AKILF](#) [ZL30314GKG2](#) [ZL30253LDG1](#) [ZL30251LDG1](#) [ZL30250LDG1](#) [ZL30169LDG1](#) [ZL30142GGG2](#) [9UMS9633BKILFT](#)
[9FGV0631CKLFT](#) [9FGV0631CKILF](#) [5P49V5935B536LTGI](#) [PI6LC48P0101LIE](#) [DS1099U-ST+](#) [MAX24305EXG+](#) [PI6LC48H02-01LIE](#)
[82P33814ANLG](#)