

### Product Summary

$V_{(BR)DSS}$	$R_{DS(on)TYP}$	$I_D$
100V	1.3mΩ@10V	340A

### Feature

- Fast Switching
- Low Gate Charge and Rdson
- Advanced Split Gate Trench Technology
- 100% Single Pulse avalanche energy Test

### Applications

- PWM Application
- Hard switched and high frequency circuits
- Power Management

### Package

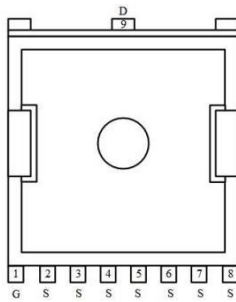

TOLL

### Circuit diagram

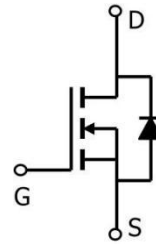

### Marking

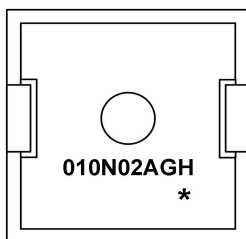

010N02AGH =Device Code  
\*\* =Week Code

**Absolute maximum ratings (Ta=25°C, unless otherwise noted)**

Parameter	Symbol	Rating	Units
Drain-Source Voltage	$V_{DS}$	100	V
Gate-Source Voltage	$V_{GS}$	$\pm 20$	V
Continuous Drain Current (Tc=25°C)	$I_D$	340	A
Pulsed Drain Current	$I_{DM}$	1360	A
Single Pulse Avalanche Energy <sup>1</sup>	$E_{AS}$	558	mJ
Total Power Dissipation <sup>2</sup> (Tc=25°C)	$P_D$	400	W
Thermal Resistance Junction-Case	$R_{\theta JC}$	0.38	°C/W
Storage Temperature Range	$T_{STG}$	-55 to 150	°C
Operating Junction Temperature Range	$T_J$	-55 to 150	°C

**Electrical characteristics (Ta=25°C, unless otherwise noted)**

Parameter	Symbol	Conditions	Min.	Typ.	Max.	Unit
<b>Static Characteristics</b>						
Drain-Source Breakdown Voltage	$BV_{DSS}$	$V_{GS}=0V, I_D=250\mu A$	100	---	---	V
Drain-Source Leakage Current	$I_{DSS}$	$V_{DS}=80V, V_{GS}=0V, T_J=25^\circ C$	---	---	1	$\mu A$
Gate-Source Leakage Current	$I_{GSS}$	$V_{GS}=\pm 20V, V_{DS}=0V$	---	---	$\pm 100$	nA
Gate Threshold Voltage	$V_{GS(th)}$	$V_{GS}=V_{DS}, I_D=250\mu A$	2	2.6	4	V
Static Drain-Source On-Resistance	$R_{DS(on)}$	$V_{GS}=10V, I_D=125A$	---	1.3	1.65	$m\Omega$
<b>Dynamic characteristics</b>						
Input Capacitance	$C_{iss}$	$V_{DS}=50V, V_{GS}=0V, f=1MHz$	---	13531	---	pF
Output Capacitance	$C_{oss}$		---	1889	---	
Reverse Transfer Capacitance	$C_{rss}$		---	82	---	
<b>Switching Characteristics</b>						
Total Gate Charge (4.5V)	$Q_g$	$V_{DS}=50V, V_{GS}=10V, I_D=125A$	---	198	---	nC
Gate-Source Charge	$Q_{gs}$		---	51	---	
Gate-Drain Charge	$Q_{gd}$		---	37	---	
Turn-On Delay Time	$T_{d(on)}$	$V_{DD}=50V, V_{GS}=10V, R_G=1.6\Omega, I_D=125A$	---	25	---	ns
Rise Time	$T_r$		---	75	---	
Turn-Off Delay Time	$T_{d(off)}$		---	89	---	
Fall Time	$T_f$		---	29	---	
<b>Diode Characteristics</b>						
Diode Forward Voltage <sup>2</sup>	$V_{SD}$	$V_{GS}=0V, I_S=1A, T_J=25^\circ C$	---	---	1.2	V

**Note :**

- The EAS data shows Max. rating . The test condition is  $V_{DD}=50V, V_{GS}=10V, L=0.5mH, R_G=25\Omega$
- The power dissipation is limited by 150°C junction temperature

**Typical Characteristics**

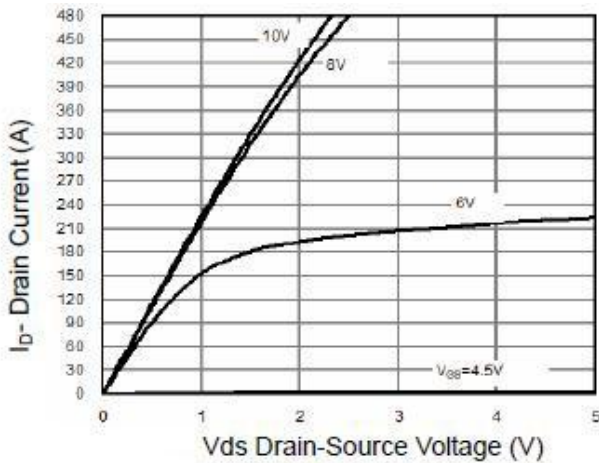

**Output Characteristics**

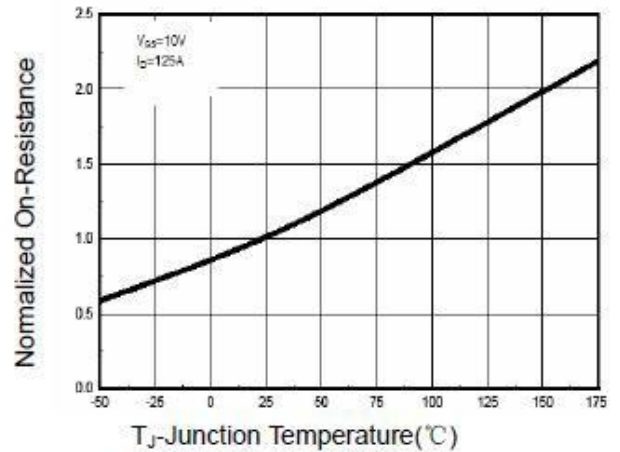

**Rdson-Junction Temperature**

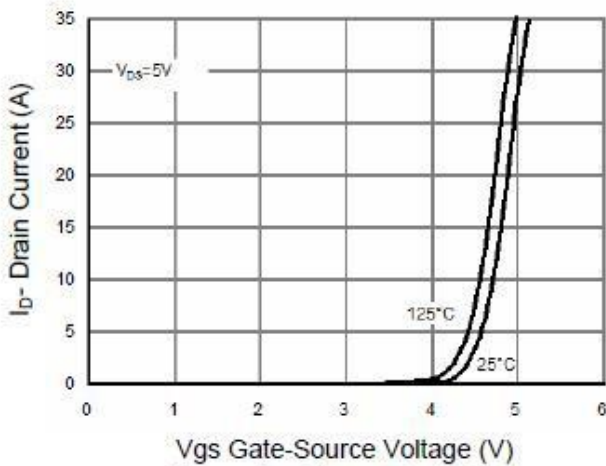

**Transfer Characteristics**

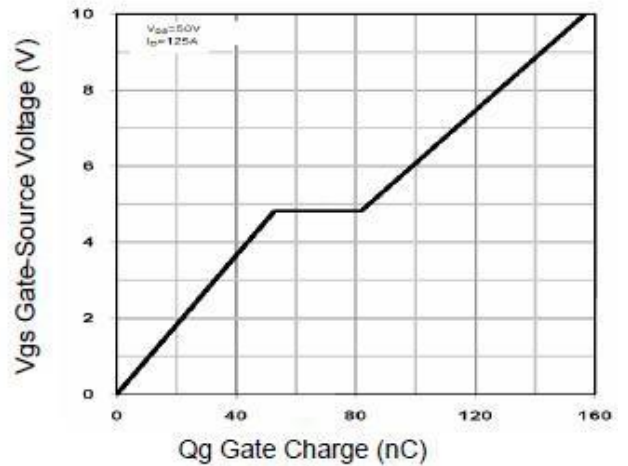

**Gate Charge**

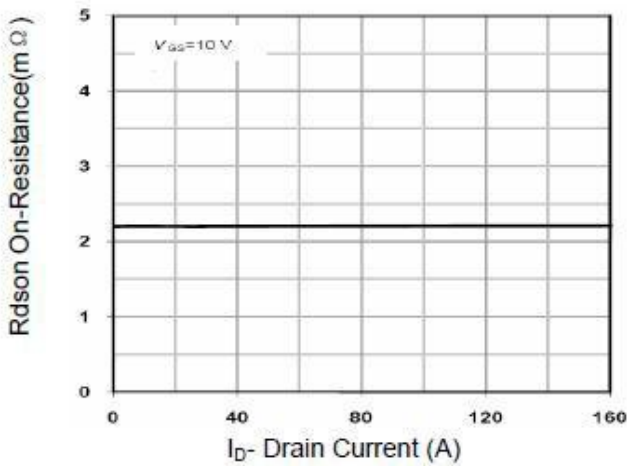

**Rdson- Drain Current**

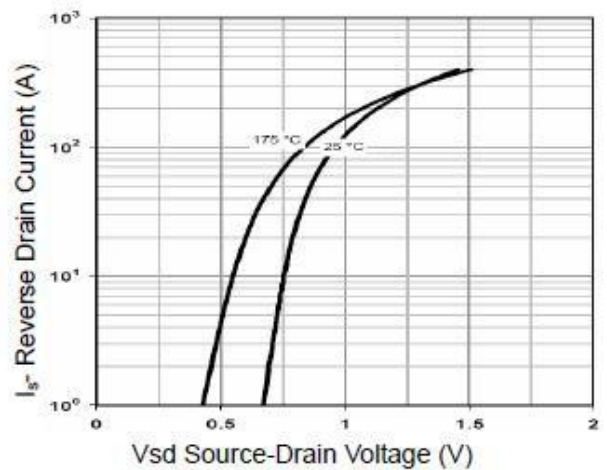

**Source- Drain Diode Forward**

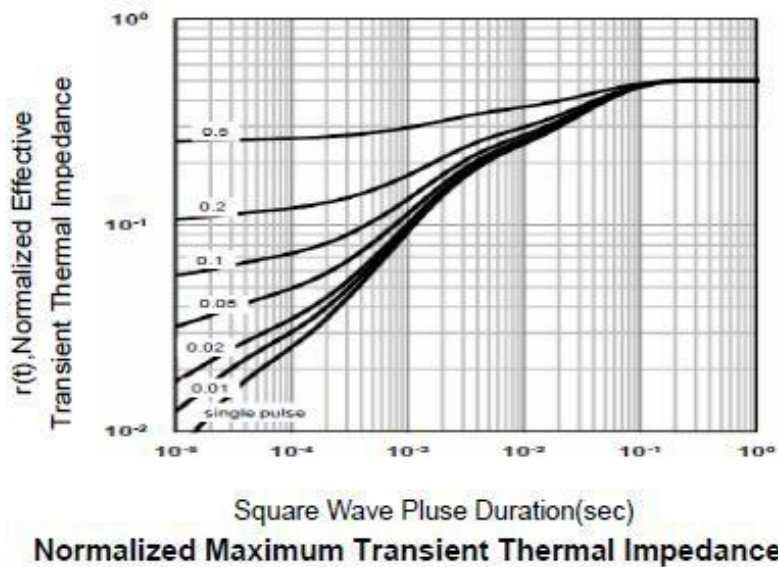
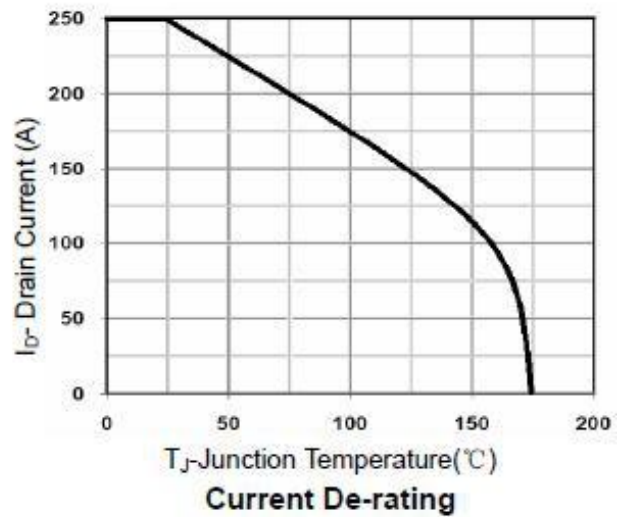
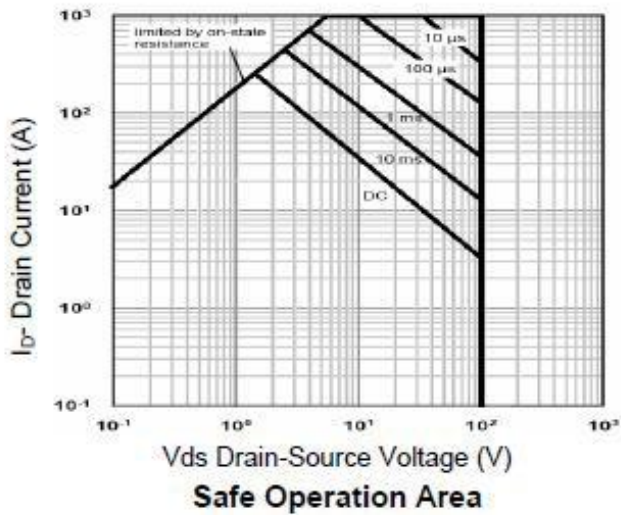
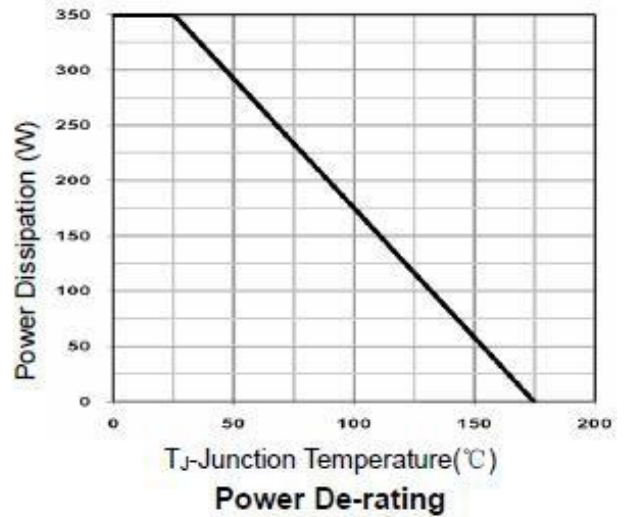
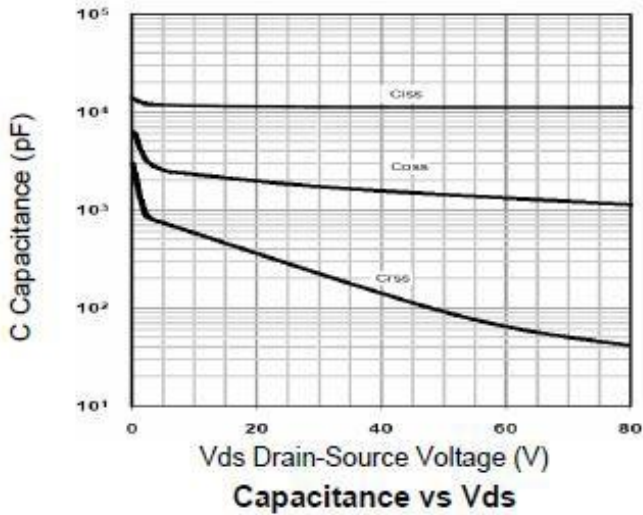



**TOLL Package Information**

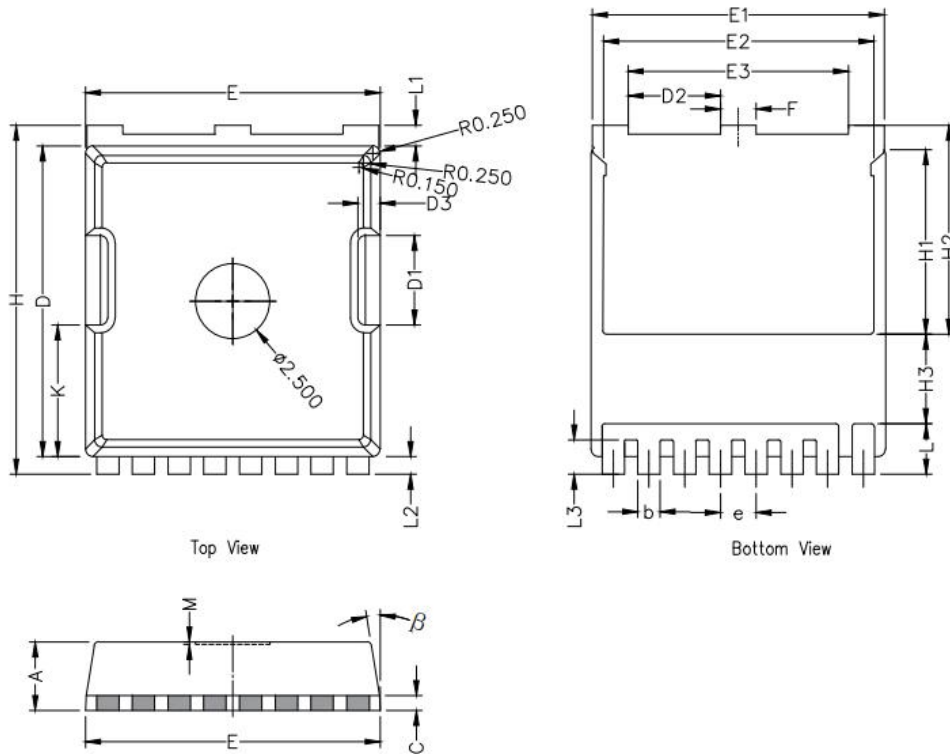

Symbol	Dimensions In Millimeters		
	Min.	Nom.	Max.
A	2.20	2.30	2.40
b	0.65	0.75	0.85
C	0.508 REF		
D	10.25	10.40	10.55
D1	2.85	3.00	3.15
E	9.75	9.90	10.05
E1	9.65	9.80	9.95
E2	8.95	9.10	9.25
E3	7.25	7.40	7.55
e	1.20 BSC		
F	1.05	1.20	1.35
H	11.55	11.70	11.85
H1	6.03	6.18	6.33
H2	6.85	7.00	7.15
H3	3.00 BSC		
L	1.55	1.70	1.85
L1	0.55	0.7	0.85
L2	0.45	0.6	0.75
M	0.08 REF.		
$\beta$	8°	10°	12°
K	4.25	4.40	4.55

## X-ON Electronics

Largest Supplier of Electrical and Electronic Components

*Click to view similar products for [MOSFET](#) category:*

*Click to view products by [Siliup](#) manufacturer:*

Other Similar products are found below :

[IRFD120](#) [IRFY240C](#) [JANTX2N5237](#) [2SK2267\(Q\)](#) [BUK455-60A/B](#) [MIC4420CM-TR](#) [VN1206L](#) [NDP4060](#) [SI4482DY](#)  
[IPS70R2K0CEAKMA1](#) [SQD23N06-31L-GE3](#) [TK16J60W,S1VQ\(O](#) [2SK2614\(TE16L1,Q\)](#) [DMN1017UCP3-7](#) [EFC2J004NUZTDG](#)  
[DMN1053UCP4-7](#) [SQJ469EP-T1-GE3](#) [NTE2384](#) [DMC2700UDMQ-7](#) [DMN2080UCB4-7](#) [DMN61D9UWQ-13](#) [US6M2GTR](#)  
[DMN31D5UDJ-7](#) [DMP22D4UFO-7B](#) [DMN1006UCA6-7](#) [DMN16M9UCA6-7](#) [STF5N65M6](#) [IRF40H233XTMA1](#) [STU5N65M6](#)  
[DMN6022SSD-13](#) [DMN13M9UCA6-7](#) [DMTH10H4M6SPS-13](#) [DMN2990UFB-7B](#) [IPB80P04P405ATMA2](#) [2N7002W-G](#) [MCAC30N06Y-](#)  
[TP](#) [MCQ7328-TP](#) [NTMC083NP10M5L](#) [NVMFS2D3P04M8LT1G](#) [BXP7N65D](#) [BXP4N65F](#) [AOL1454G](#) [WMJ80N60C4](#) [BXP2N20L](#)  
[BXP2N65D](#) [BXT1150N10J](#) [BXT1700P06M](#) [TSM60NB380CP](#) [ROG](#) [RQ7L055BGTCR](#) [DMNH15H110SK3-13](#)