

Product Summary

$V_{(BR)DSS}$	$R_{DS(on)TYP}$	I_D
30V	9mΩ@10V	22A
	10mΩ@4.5V	
-30V	20mΩ@-10V	-18A
	28mΩ@-4.5V	

Feature

- TrenchFET Power MOSFET
- Excellent $R_{DS(on)}$ and Low Gate Charge
- Fast Switching Speed

Application

- Motor Control
- Inverters

Package

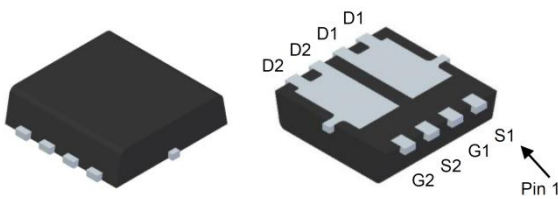

PDFNWB3.3×3.3-8L-B

Circuit diagram

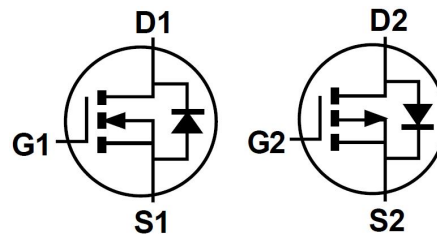

Marking

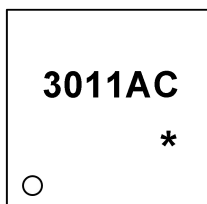

3011AC = Device code
* = Month Code

Absolute maximum ratings (Ta=25°C unless otherwise noted)

Parameter	Symbol	Value		Unit
		N-Channel	P-Channel	
Drain-Source Voltage	V_{DS}	30	-30	V
Gate-Source Voltage	V_{GS}	± 20	± 20	V
Continuous Drain Current($t \leq 10s$)	I_D	22	-18	A
Power Dissipation($t \leq 10s$)	P_D	28	20	W
Thermal Resistance from Junction to Ambient($t \leq 10s$)	$R_{\theta JA}$	4.46	6.25	$^{\circ}C/W$
Junction Temperature	T_J	150		$^{\circ}C$
Storage Temperature	T_{STG}	-55~ +150		$^{\circ}C$

N-Channel Electrical characteristics (T_A=25 °C, unless otherwise noted)

Parameter	Symbol	Test Condition	Min.	Typ.	Max.	Unit
Static Characteristics						
Drain-source breakdown voltage	$V_{(BR)DSS}$	$V_{GS} = 0V, I_D = 250\mu A$	30			V
Zero gate voltage drain current	I_{DSS}	$V_{DS} = 24V, V_{GS} = 0V$			1	μA
Gate-body leakage current	I_{GSS}	$V_{GS} = \pm 20V, V_{DS} = 0V$			± 100	nA
Gate threshold voltage	$V_{GS(th)}$	$V_{DS} = V_{GS}, I_D = 250\mu A$	1	1.5	2.5	V
Drain-source on-resistance	$R_{DS(on)}$	$V_{GS} = 10V, I_D = 8A$		9	11	m Ω
		$V_{GS} = 4.5V, I_D = 6A$		10	13	
Dynamic characteristics						
Input Capacitance	C_{iss}	$V_{DS} = 15V, V_{GS} = 0V, f = 1MHz$		1060		pF
Output Capacitance	C_{oss}			85		
Reverse Transfer Capacitance	C_{rss}			56		
Switching Characteristics						
Total gate charge	Q_g	$V_{DS} = 15V, V_{GS} = 4.5V, I_D = 8A$		13.8		nC
Gate-source charge	Q_{gs}			3.6		
Gate-drain charge	Q_{gd}			5.5		
Turn-on delay time	$t_{d(on)}$	$V_{DD} = 15V, V_{GS} = 10V, RG = 1.5, I_D = 8A$		5.2		ns
Turn-on rise time	t_r			8.2		
Turn-off delay time	$t_{d(off)}$			31		
Turn-off fall time	t_f			4		
Source-Drain Diode Characteristics						
Body Diode Voltage	V_{SD}	$I_S = 1A, V_{GS} = 0V$			1.2	V

P-Channel Electrical characteristics (T_A=25 °C, unless otherwise noted)

Parameter	Symbol	Test Condition	Min.	Typ.	Max.	Unit
Static Characteristics						
Drain-source breakdown voltage	V _{(BR)DSS}	V _{GS} = 0V, I _D = -250μA	-30			V
Zero gate voltage drain current	I _{DSS}	V _{DS} = -24V, V _{GS} = 0V			1	μA
Gate-body leakage current	I _{GSS}	V _{GS} = ±20V, V _{DS} = 0V			±100	nA
Gate threshold voltage	V _{GS(th)}	V _{DS} = V _{GS} , I _D = -250μA	-1	-1.5	-2.5	V
Drain-source on-resistance	R _{DS(on)}	V _{GS} = -10V, I _D = -8A		20	24	mΩ
		V _{GS} = -4.5V, I _D = -6A		28	38	
Dynamic characteristics						
Input Capacitance	C _{iss}	V _{DS} = -15V, V _{GS} = 0V, f = 1MHz		1650		pF
Output Capacitance	C _{oss}			367		
Reverse Transfer Capacitance	C _{rss}			297		
Switching Characteristics						
Total gate charge	Q _g	V _{DS} = -15V, V _{GS} = -4.5V, I _D = -8A		32		nC
Gate-source charge	Q _{gs}			4.8		
Gate-drain charge	Q _{gd}			7		
Turn-on delay time	t _{d(on)}	V _{DD} = -15V, I _D = -1A, V _{GS} = -10V, R _{GEN} = 6Ω		9		ns
Turn-on rise time	t _r			12		
Turn-off delay time	t _{d(off)}			102		
Turn-off fall time	t _f			71		
Source-Drain Diode Characteristics						
Body Diode Voltage	V _{SD}	I _S = -1A, V _{GS} = 0V			-1.2	V

N-Channel Typical Characteristics

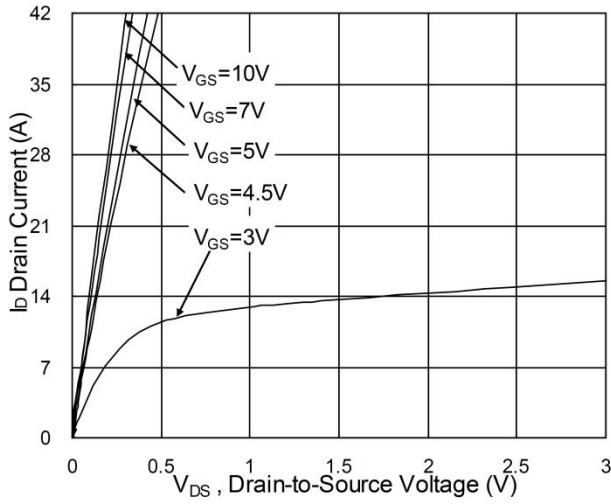

Typical Output Characteristics

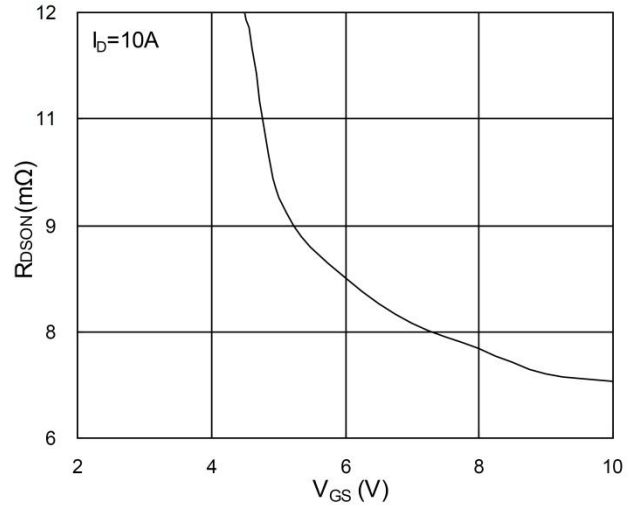

On-Resistance vs. Gate-Source

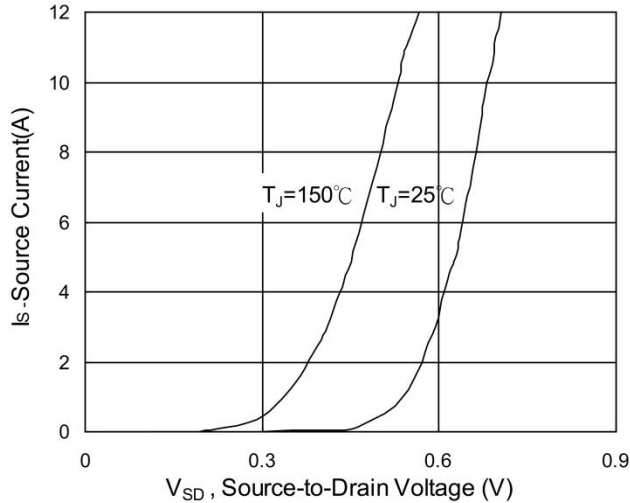

Forward Characteristics of reverse

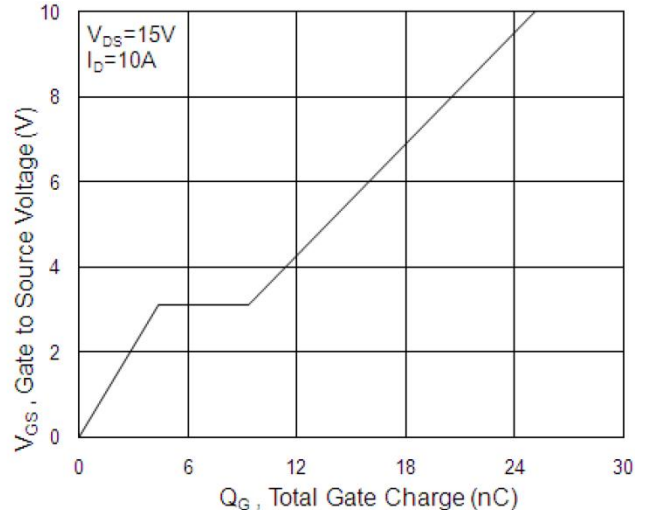

Gate-Charge Characteristics

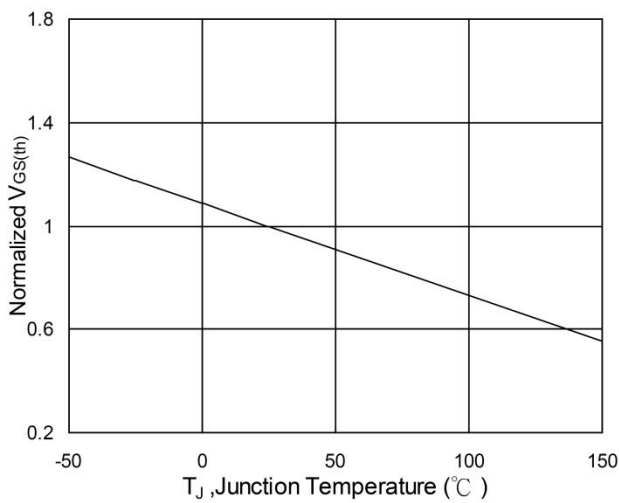

Normalized $V_{GS(th)}$ vs. T_J

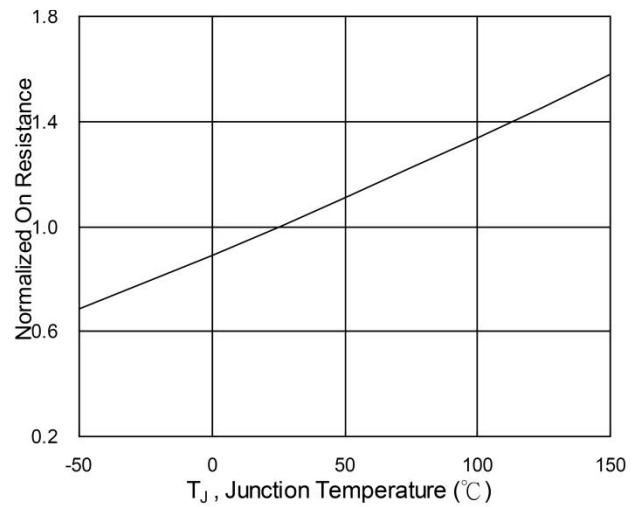

Normalized $R_{DS(on)}$ vs. T_J

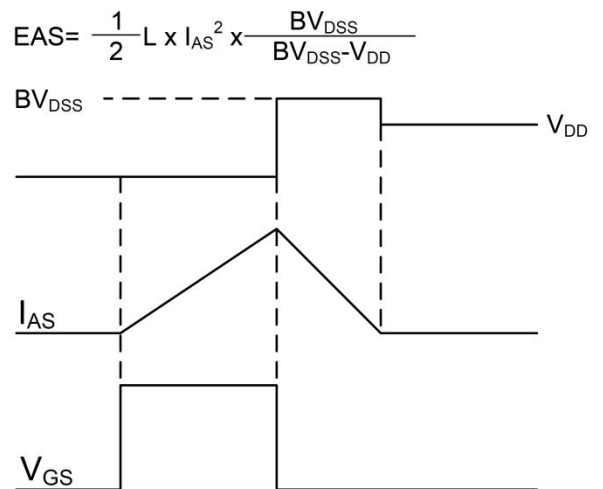
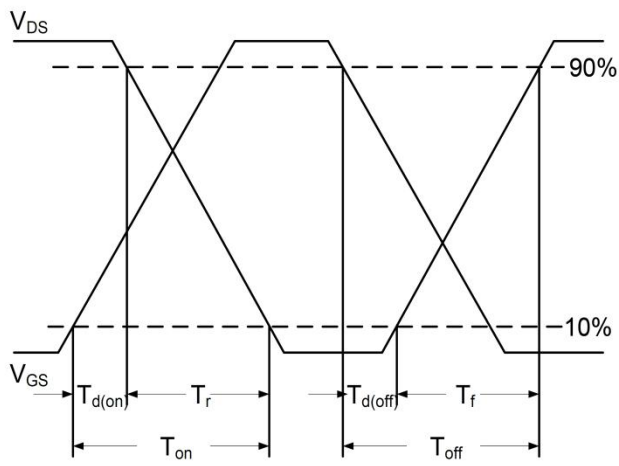
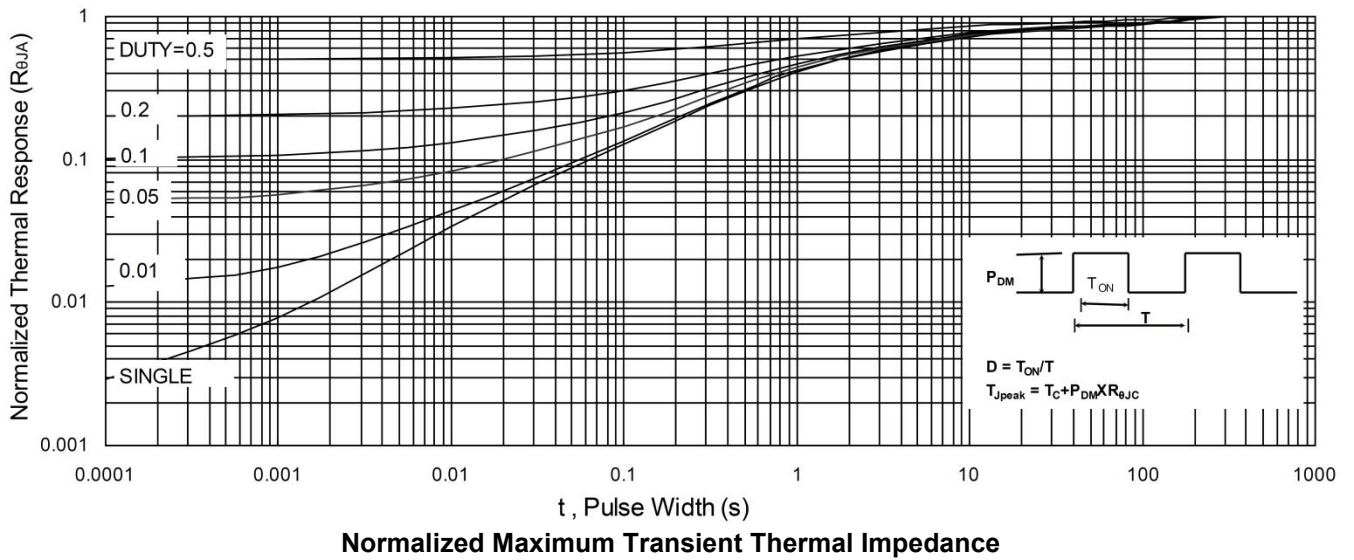
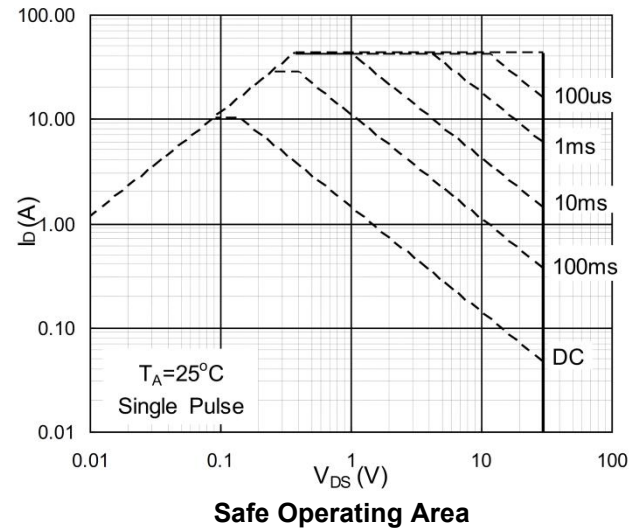
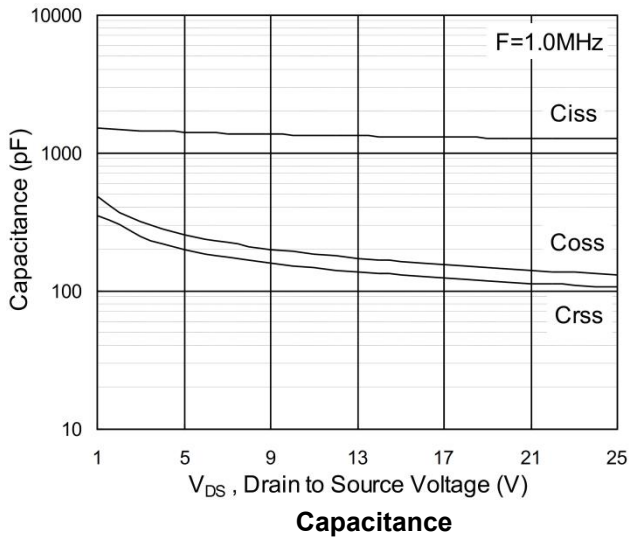

$$EAS = \frac{1}{2} L \times I_{AS}^2 \times \frac{BV_{DSS}}{BV_{DSS} - V_{DD}}$$

P-Channel Typical Characteristics

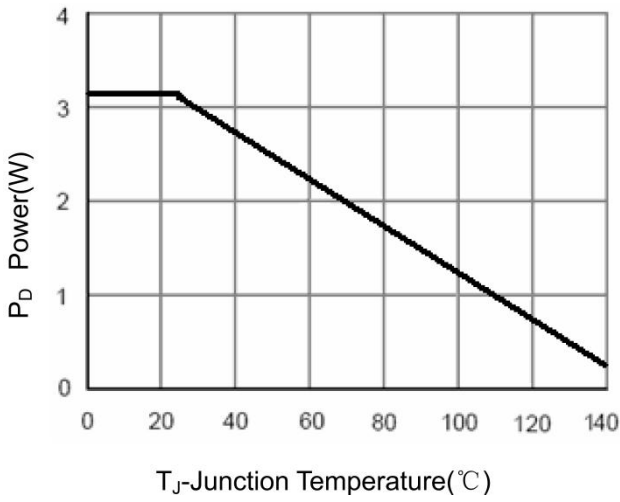

Power Dissipation

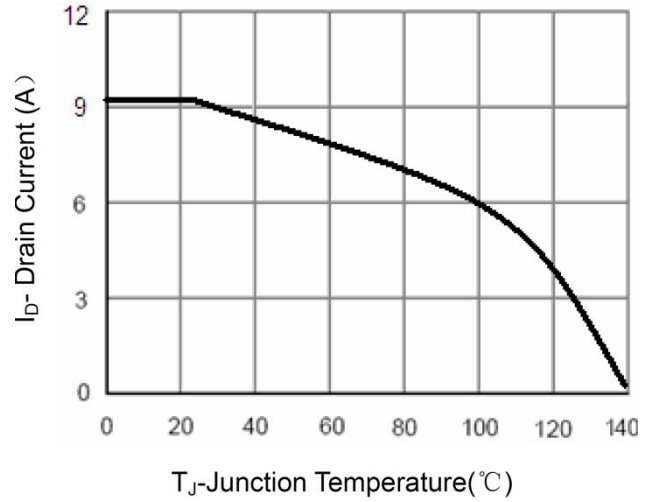

Drain Current

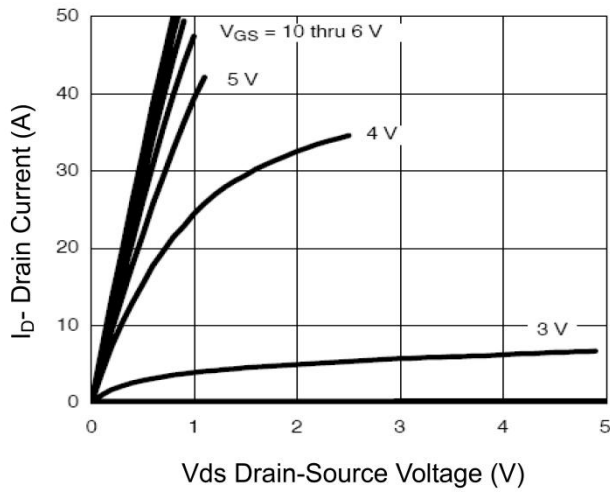

Output Characteristics

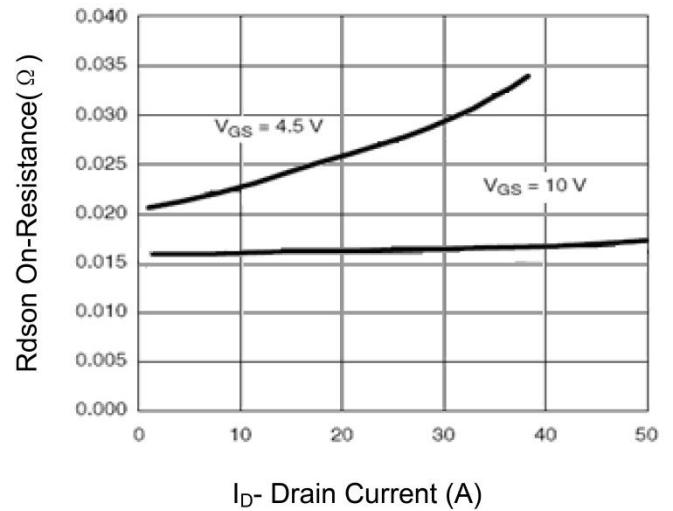

Drain-Source On-Resistance

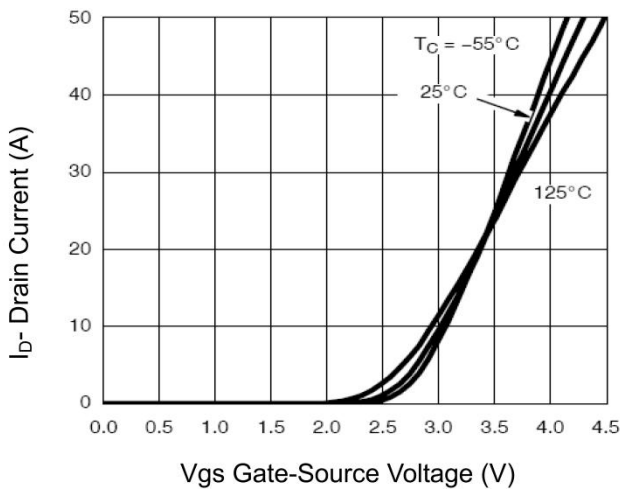

Transfer Characteristics

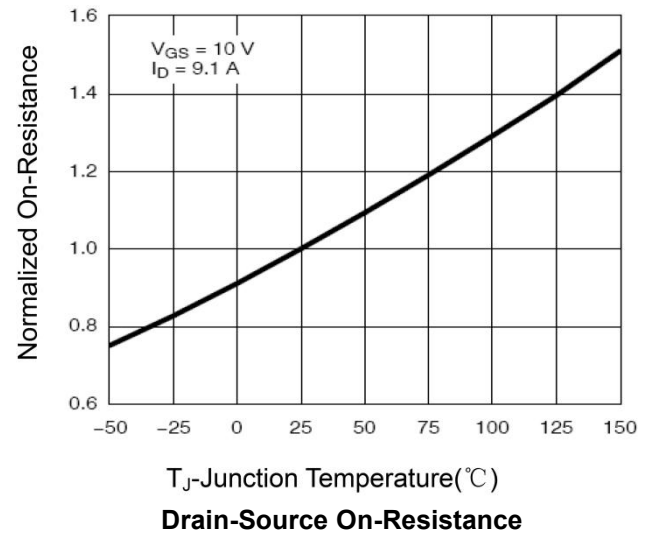

Drain-Source On-Resistance

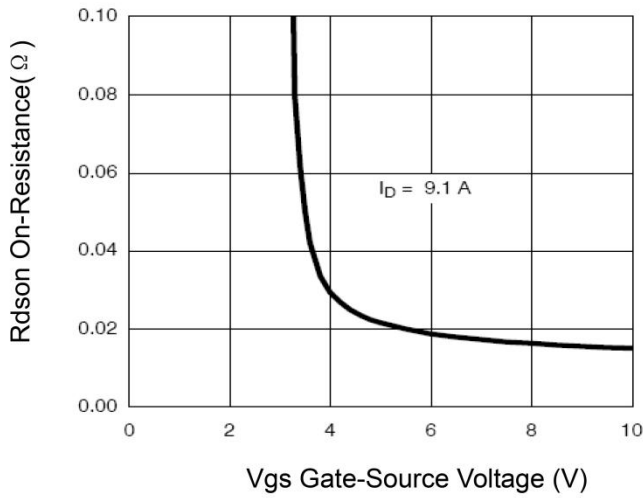

Rdson vs Vgs

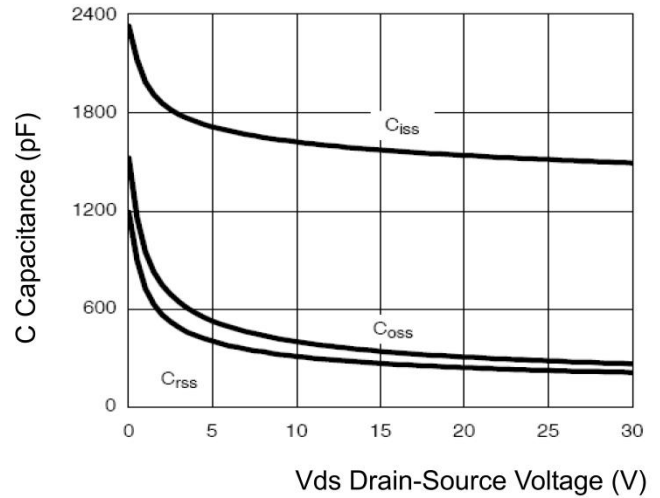

Capacitance vs Vds

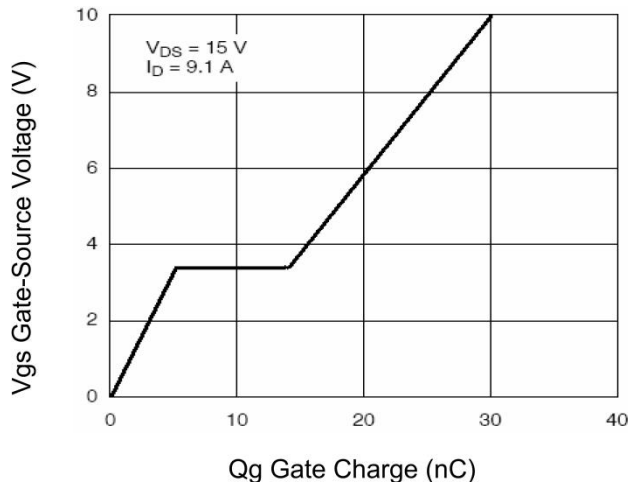

Gate Charge

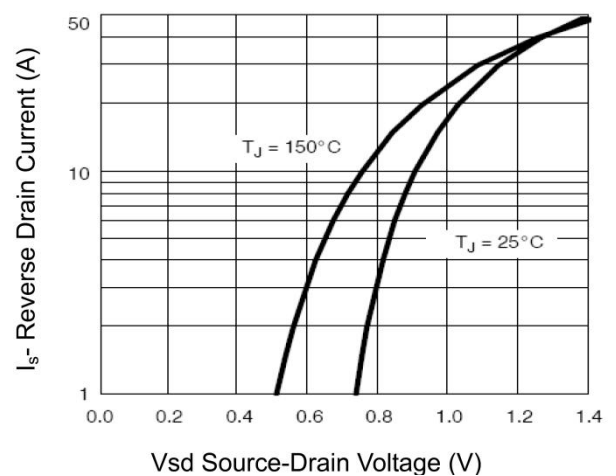

Source- Drain Diode Forward

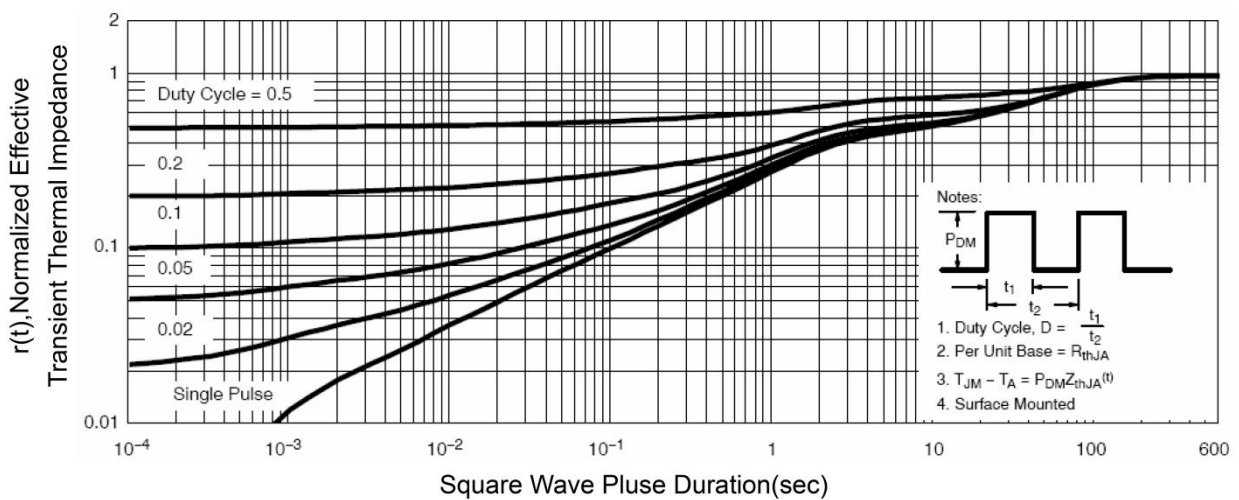

Normalized Maximum Transient Thermal Impedance



PDFNWB3.3×3.3-8L-B Package Information

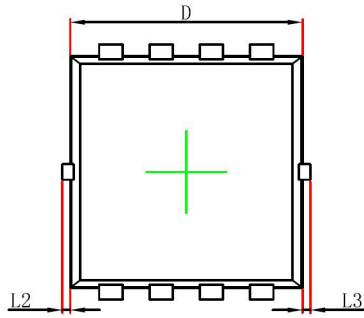

Top View
[顶视图]

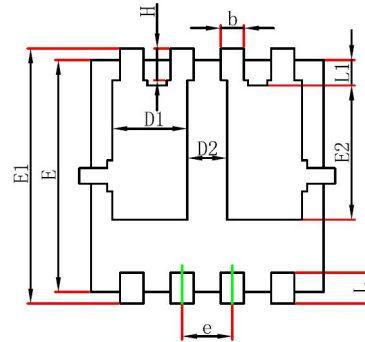

Bottom View
[背视图]

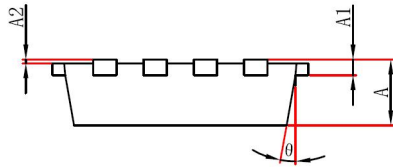

Side View
[侧视图]

Symbol	Dimensions In Millimeters		Dimensions In Inches	
	Min.	Max.	Min.	Max.
A	0.650	0.850	0.026	0.033
A1	0.152 REF.		0.006 REF.	
A2	0~0.05		0~0.002	
D	2.900	3.100	0.114	0.122
D1	0.935	1.135	0.037	0.045
D2	0.280	0.480	0.011	0.019
E	2.900	3.100	0.114	0.122
E1	3.150	3.450	0.124	0.136
E2	1.535	1.935	0.060	0.076
b	0.200	0.400	0.008	0.016
e	0.550	0.750	0.022	0.030
L	0.300	0.500	0.012	0.020
L1	0.180	0.480	0.007	0.019
L2	0~0.100		0~0.004	
L3	0~0.100		0~0.004	
H	0.315	0.515	0.012	0.020
θ	9°	13°	9°	13°

X-ON Electronics

Largest Supplier of Electrical and Electronic Components

Click to view similar products for [MOSFET](#) category:

Click to view products by [Siliup](#) manufacturer:

Other Similar products are found below :

[IRFD120](#) [IRFY240C](#) [JANTX2N5237](#) [2SK2267\(Q\)](#) [BUK455-60A/B](#) [MIC4420CM-TR](#) [VN1206L](#) [NDP4060](#) [SI4482DY](#)
[IPS70R2K0CEAKMA1](#) [SQD23N06-31L-GE3](#) [TK16J60W,S1VQ\(O](#) [2SK2614\(TE16L1,Q\)](#) [DMN1017UCP3-7](#) [EFC2J004NUZTDG](#)
[DMN1053UCP4-7](#) [SQJ469EP-T1-GE3](#) [NTE2384](#) [DMC2700UDMQ-7](#) [DMN2080UCB4-7](#) [DMN61D9UWQ-13](#) [US6M2GTR](#)
[DMN31D5UDJ-7](#) [DMP22D4UFO-7B](#) [DMN1006UCA6-7](#) [DMN16M9UCA6-7](#) [STF5N65M6](#) [IRF40H233XTMA1](#) [STU5N65M6](#)
[DMN6022SSD-13](#) [DMN13M9UCA6-7](#) [DMTH10H4M6SPS-13](#) [DMN2990UFB-7B](#) [IPB80P04P405ATMA2](#) [2N7002W-G](#) [MCAC30N06Y-](#)
[TP](#) [MCQ7328-TP](#) [NTMC083NP10M5L](#) [NVMFS2D3P04M8LT1G](#) [BXP7N65D](#) [BXP4N65F](#) [AOL1454G](#) [WMJ80N60C4](#) [BXP2N20L](#)
[BXP2N65D](#) [BXT1150N10J](#) [BXT1700P06M](#) [TSM60NB380CP](#) [ROG](#) [RQ7L055BGTCR](#) [DMNH15H110SK3-13](#)