

Product Summary

$V_{(BR)DSS}$	$R_{DS(on)TYP}$	I_D
30V	11mΩ@10V	24A
	17mΩ@4.5V	
-30V	20mΩ@-10V	-21A
	29mΩ@-4.5V	

Feature

- TrenchFET Power MOSFET
- Excellent $R_{DS(on)}$ and Low Gate Charge
- Fast Switching Speed

Application

- Motor Control
- Inverters

Package

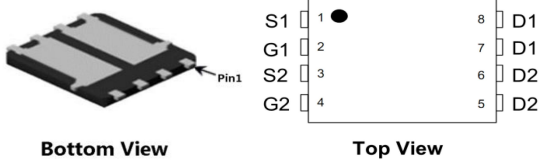

PDFN5×6-8L

Circuit diagram

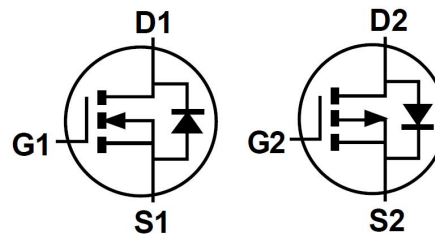

Marking

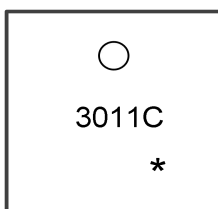

3011C = Device code
* = Month Code

Absolute maximum ratings (Ta=25°C unless otherwise noted)

Parameter	Symbol	Value		Unit
		N-Channel	P-Channel	
Drain-Source Voltage	V_{DS}	30	-30	V
Gate-Source Voltage	V_{GS}	± 20	± 20	V
Continuous Drain Current($t \leq 10s$)	I_D	24	-21	A
Single Pulse Avalanche Energy	E_{AS}	129	169	mJ
Power Dissipation($t \leq 10s$)	P_D	26	22	W
Thermal Resistance from Junction to Ambient($t \leq 10s$)	$R_{\theta JA}$	4.81	5.68	$^{\circ}C/W$
Junction Temperature	T_J	150		$^{\circ}C$
Storage Temperature	T_{STG}	-55~ +150		$^{\circ}C$

N-Channel Electrical characteristics (T_A=25 °C, unless otherwise noted)

Parameter	Symbol	Test Condition	Min.	Typ.	Max.	Unit
Static Characteristics						
Drain-source breakdown voltage	$V_{(BR)DSS}$	$V_{GS} = 0V, I_D = 250\mu A$	30			V
Zero gate voltage drain current	I_{DSS}	$V_{DS} = 24V, V_{GS} = 0V$			1	μA
Gate-body leakage current	I_{GSS}	$V_{GS} = \pm 20V, V_{DS} = 0V$			± 100	nA
Gate threshold voltage	$V_{GS(th)}$	$V_{DS} = V_{GS}, I_D = 250\mu A$	1	1.5	2.5	V
Drain-source on-resistance	$R_{DS(on)}$	$V_{GS} = 10V, I_D = 8A$		11	15	m Ω
		$V_{GS} = 4.5V, I_D = 6A$		17	23	
Dynamic characteristics						
Input Capacitance	C_{iss}	$V_{DS} = 15V, V_{GS} = 0V, f = 1MHz$		940		pF
Output Capacitance	C_{oss}			131		
Reverse Transfer Capacitance	C_{rss}			109		
Switching Characteristics						
Total gate charge	Q_g	$V_{DS} = 15V, V_{GS} = 4.5V, I_D = 8A$		9.63		nC
Gate-source charge	Q_{gs}			3.88		
Gate-drain charge	Q_{gd}			3.44		
Turn-on delay time	$t_{d(on)}$	$V_{DD} = 15V, V_{GS} = 10V, RG = 1.5, I_D = 8A$		4.2		ns
Turn-on rise time	t_r			8.2		
Turn-off delay time	$t_{d(off)}$			31		
Turn-off fall time	t_f			4		
Source-Drain Diode Characteristics						
Body Diode Voltage	V_{SD}	$I_S = 1A, V_{GS} = 0V$			1.2	V

Notes:

1. Repetitive Rating: Pulse width limited by maximum junction temperature.
2. EAS data shows Max. rating . The test condition is $V_{DD} = 15V, V_{GS} = 10V, L = 0.5mH$
3. Pulse Test: Pulse Width $\leq 300\mu s$, Duty Cycle $\leq 2\%$.
4. Guaranteed by design, not subject to production

P-Channel Electrical characteristics (T_A=25 °C, unless otherwise noted)

Parameter	Symbol	Test Condition	Min.	Typ.	Max.	Unit
Static Characteristics						
Drain-source breakdown voltage	V _{(BR)DSS}	V _{GS} = 0V, I _D = -250μA	-30			V
Zero gate voltage drain current	I _{DSS}	V _{DS} = -24V, V _{GS} = 0V			1	μA
Gate-body leakage current	I _{GSS}	V _{GS} = ±20V, V _{DS} = 0V			±100	nA
Gate threshold voltage	V _{GS(th)}	V _{DS} = V _{GS} , I _D = -250μA	-1	-1.5	-2.5	V
Drain-source on-resistance	R _{DS(on)}	V _{GS} = -10V, I _D = -8A		20	24	mΩ
		V _{GS} = -4.5V, I _D = -6A		29	38	
Dynamic characteristics						
Input Capacitance	C _{iss}	V _{DS} = -15V, V _{GS} = 0V, f = 1MHz		1600		pF
Output Capacitance	C _{oss}			350		
Reverse Transfer Capacitance	C _{rss}			300		
Switching Characteristics						
Total gate charge	Q _g	V _{DS} = -15V, V _{GS} = -4.5V, I _D = -8A		30		nC
Gate-source charge	Q _{gs}			5.5		
Gate-drain charge	Q _{gd}			8		
Turn-on delay time	t _{d(on)}	V _{DD} = -15V, I _D = -1A, V _{GS} = -10V, R _{GEN} = 6Ω		10		ns
Turn-on rise time	t _r			15		
Turn-off delay time	t _{d(off)}			110		
Turn-off fall time	t _f			70		
Source-Drain Diode Characteristics						
Body Diode Voltage	V _{SD}	I _S = -1A, V _{GS} = 0V			-1.2	V

Notes:

5. Repetitive Rating: Pulse width limited by maximum junction temperature.
6. EAS data shows Max. rating . The test condition is V_{DD} = -15V, V_{GS} = -10V, L = 0.5mH
7. Pulse Test: Pulse Width ≤ 300μs, Duty Cycle ≤ 2%.
8. Guaranteed by design, not subject to production

N-Channel Typical Characteristics

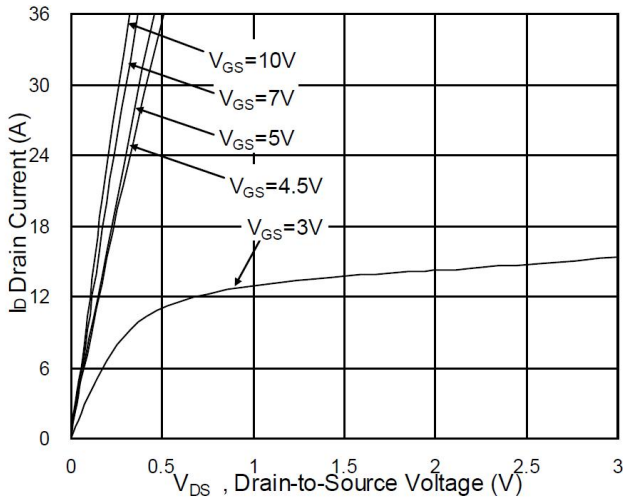

Typical Output Characteristics

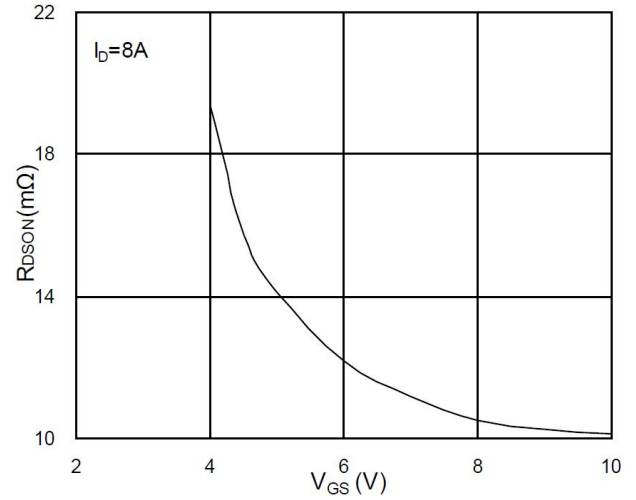

On-Resistance vs. Gate-Source

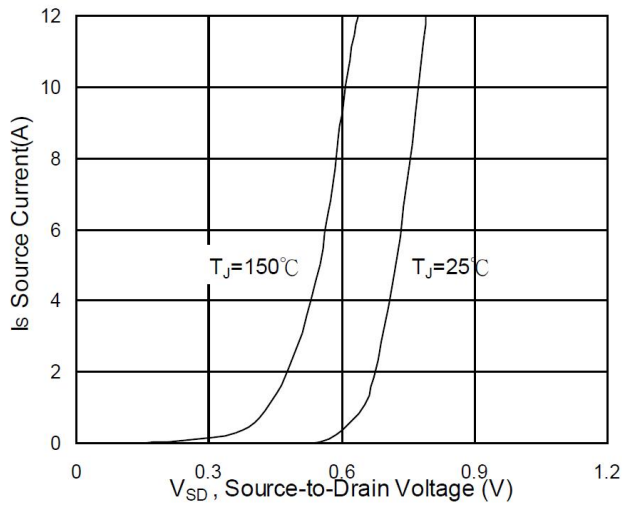

Forward Characteristics Of Reverse

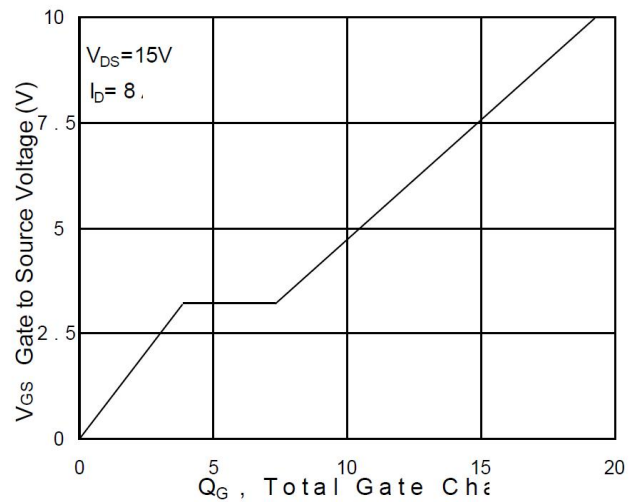

Gate-Charge Characteristics

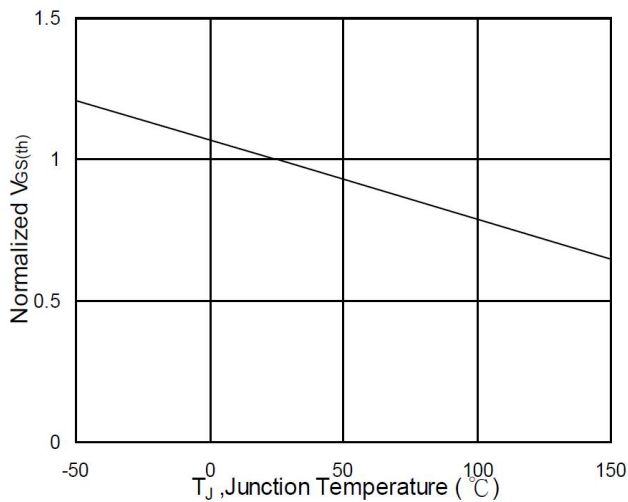

Normalized $V_{GS(th)}$ vs. T_J

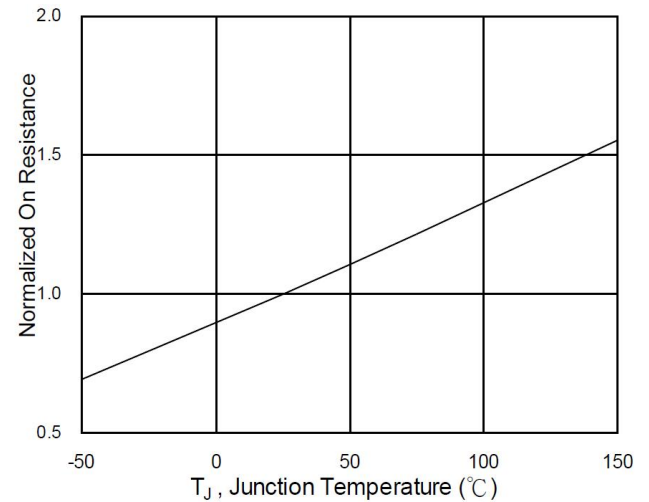

Normalized $R_{DS(on)}$ vs. T_J

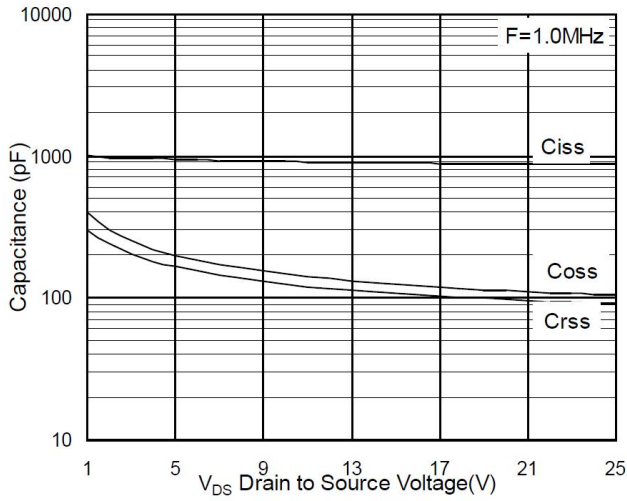

Capacitance

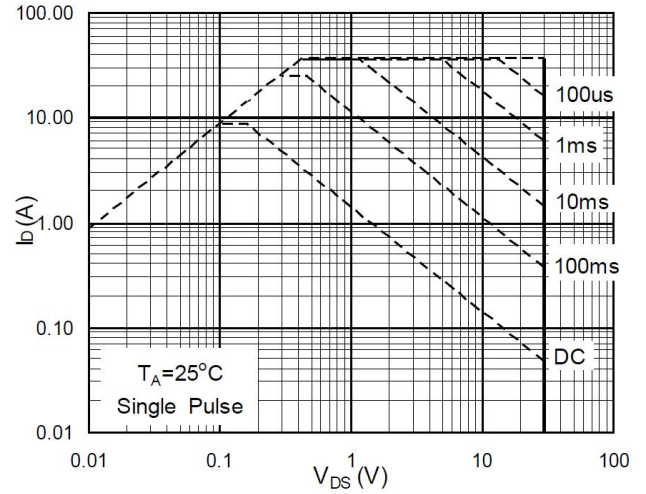

Safe Operating Area

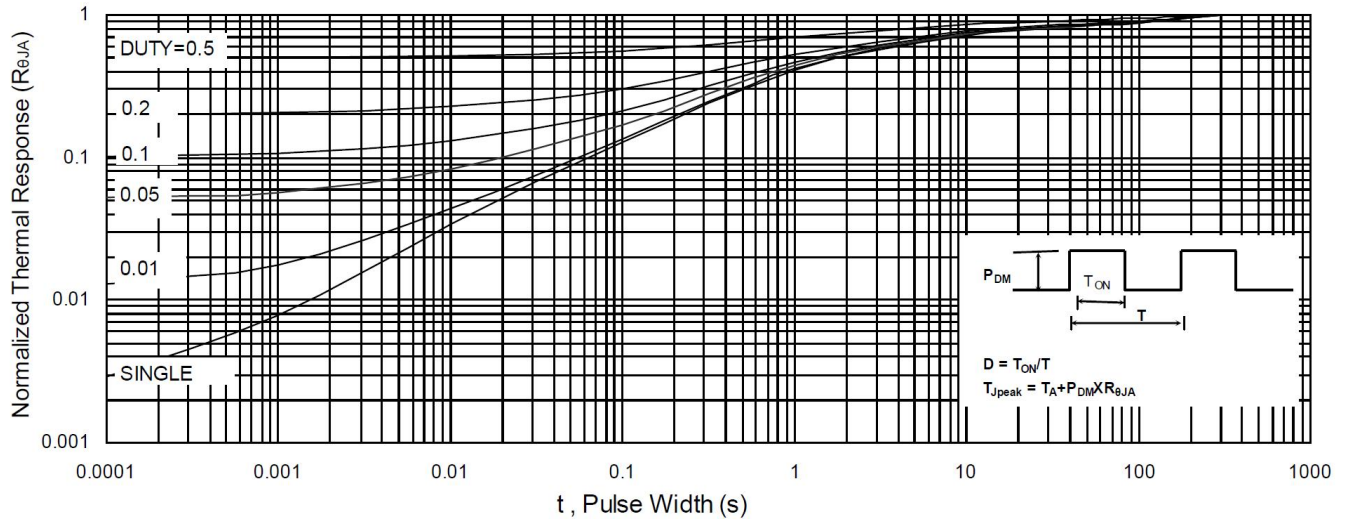

Normalized Maximum Transient Thermal Impedance

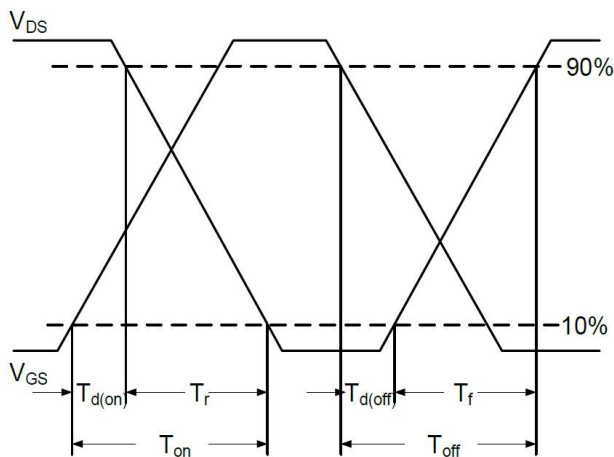

Switching Time Waveform

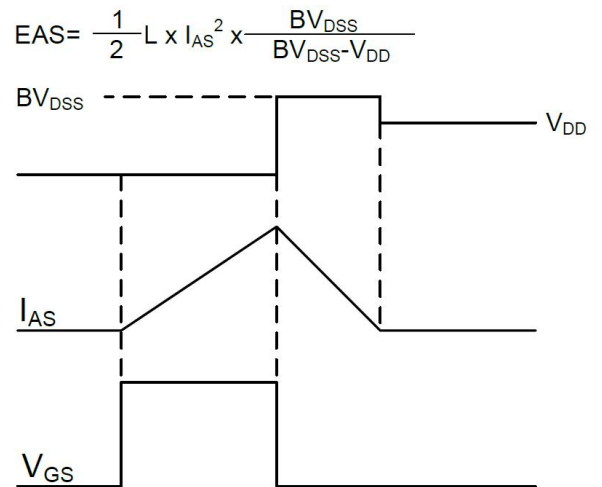

Unclamped Inductive Switching Waveform

P-Channel Typical Characteristics

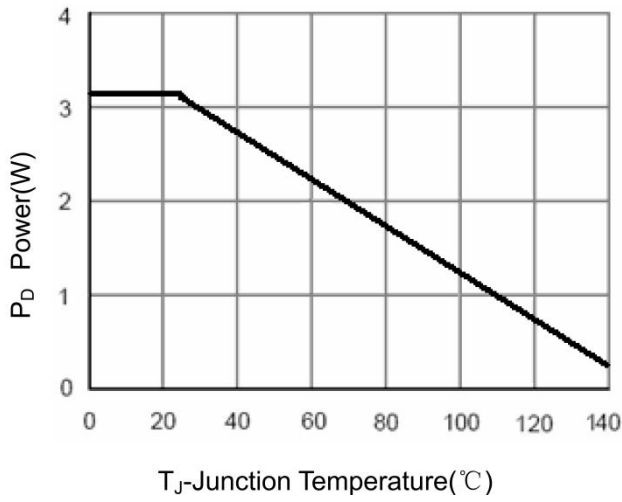

Power Dissipation

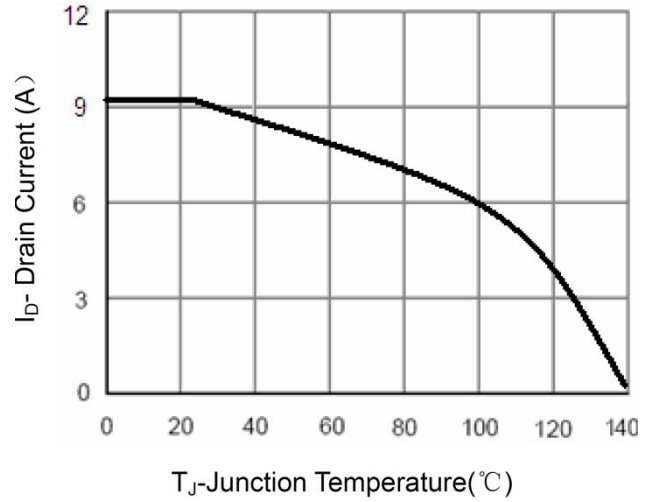

Drain Current

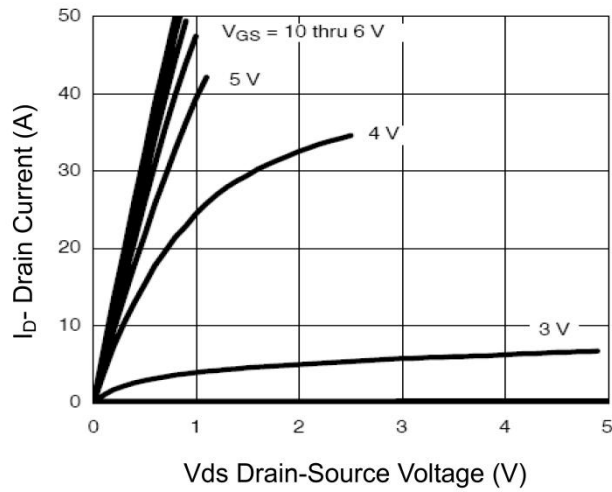

Output Characteristics

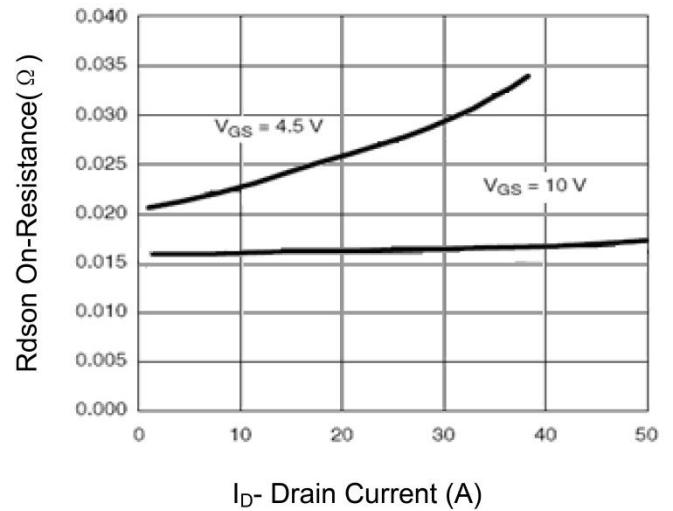

Drain-Source On-Resistance

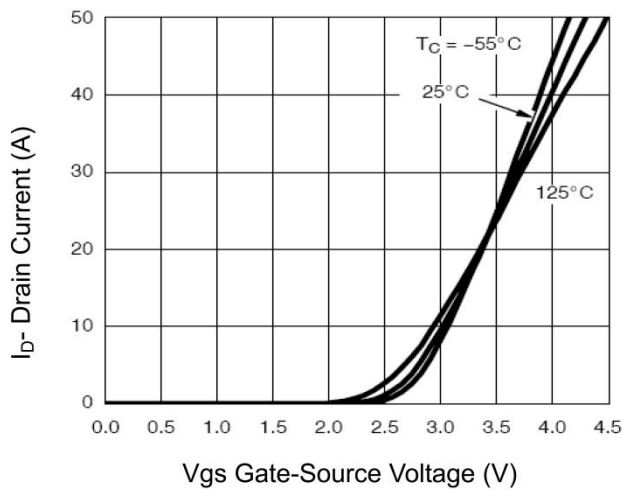

Transfer Characteristics

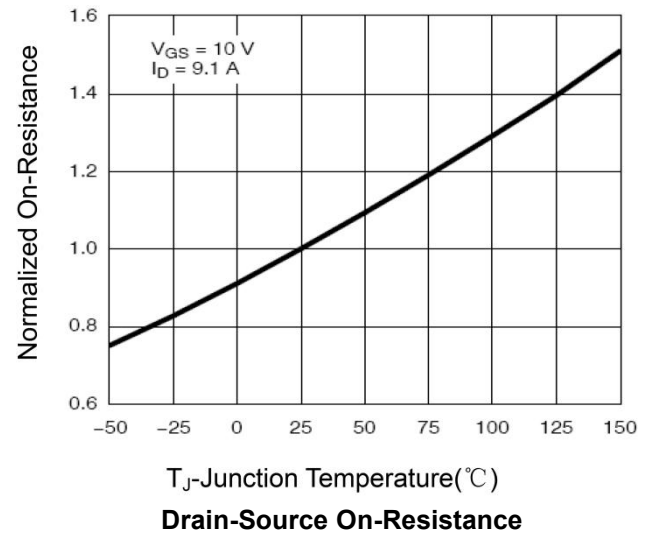

Drain-Source On-Resistance

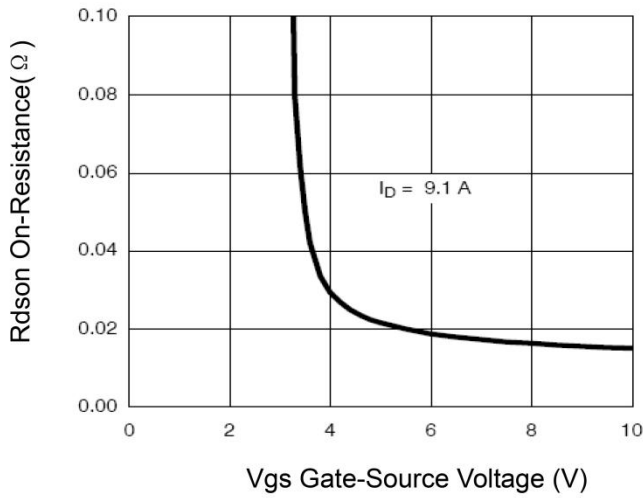

Rdson vs Vgs

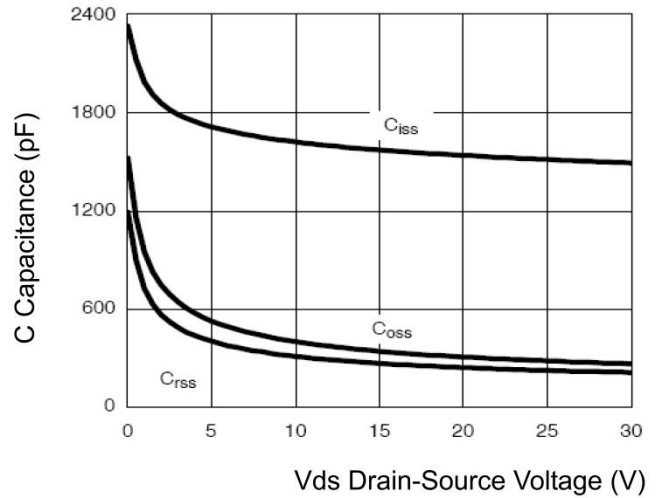

Capacitance vs Vds

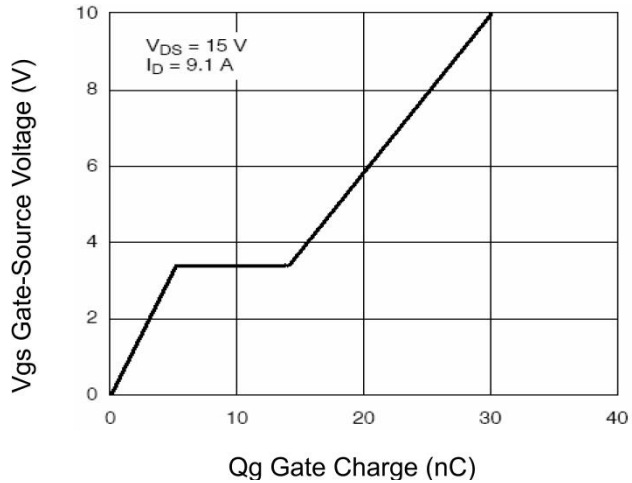

Gate Charge

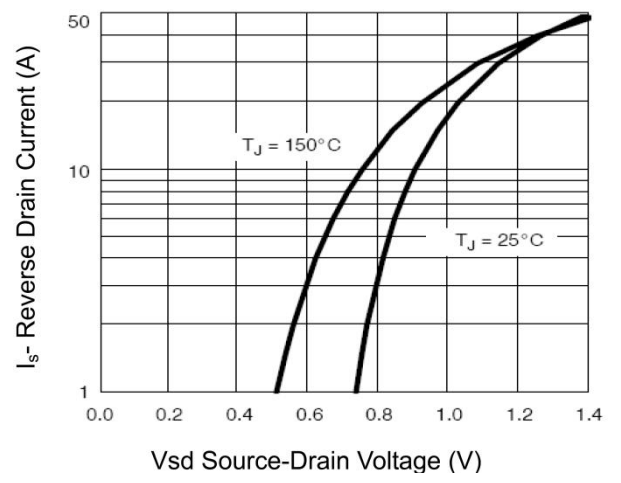

Source- Drain Diode Forward

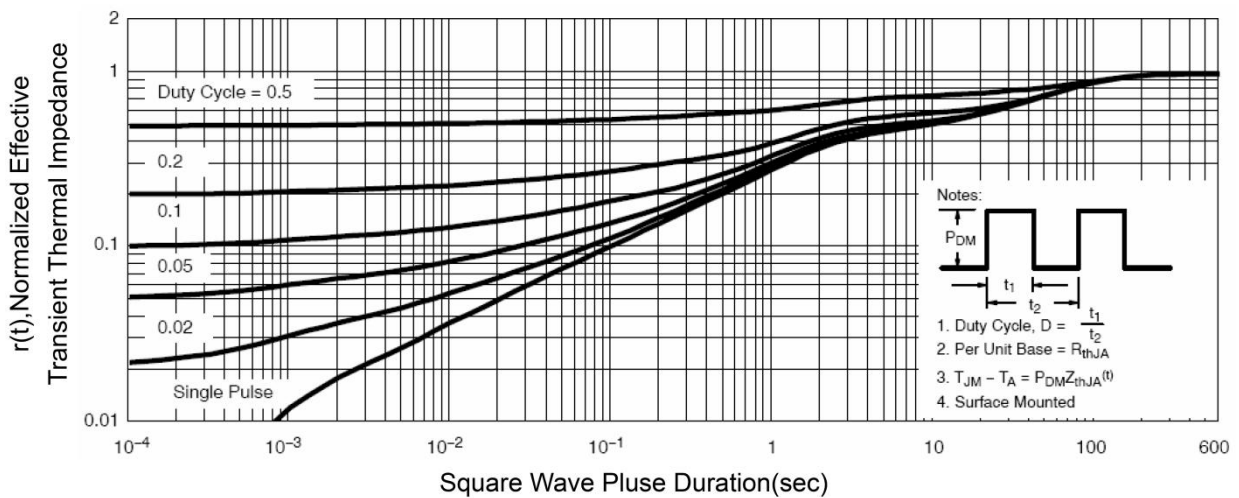

Normalized Maximum Transient Thermal Impedance



PDFN5X6-8L Package Information

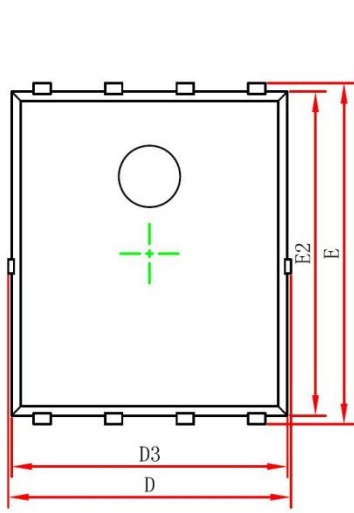

Top View [顶视图]

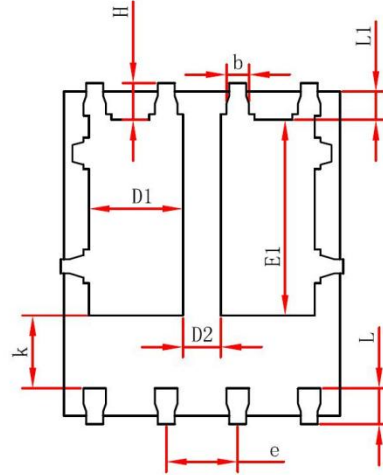

Bottom View [背视图]

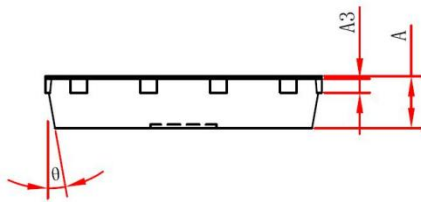

Side View [侧视图]

Symbol	Dimensions In Millimeters		Dimensions In Inches	
	Min.	Max.	Min.	Max.
A	0.900	1.000	0.035	0.039
A3	0.254 REF.		0.010REF.	
D	4.944	5.096	0.195	0.201
E	5.974	6.126	0.235	0.241
D1	1.470	1.870	0.058	0.074
D2	0.470	0.870	0.019	0.034
E1	3.375	3.575	0.133	0.141
D3	4.824	4.976	0.190	0.196
E2	5.674	5.826	0.223	0.229
k	1.190	1.390	0.047	0.055
b	0.350	0.450	0.014	0.018
e	1.270TYP.		0.050TYP.	
L	0.559	0.711	0.022	0.028
L1	0.424	0.576	0.017	0.023
H	0.574	0.726	0.023	0.029
θ	10°	12°	10°	12°

X-ON Electronics

Largest Supplier of Electrical and Electronic Components

Click to view similar products for [MOSFET](#) category:

Click to view products by [Siliup](#) manufacturer:

Other Similar products are found below :

[IRFD120](#) [IRFY240C](#) [JANTX2N5237](#) [2SK2267\(Q\)](#) [BUK455-60A/B](#) [MIC4420CM-TR](#) [VN1206L](#) [NDP4060](#) [SI4482DY](#)
[IPS70R2K0CEAKMA1](#) [SQD23N06-31L-GE3](#) [TK16J60W,S1VQ\(O](#) [2SK2614\(TE16L1,Q\)](#) [DMN1017UCP3-7](#) [EFC2J004NUZTDG](#)
[DMN1053UCP4-7](#) [SQJ469EP-T1-GE3](#) [NTE2384](#) [DMC2700UDMQ-7](#) [DMN2080UCB4-7](#) [DMN61D9UWQ-13](#) [US6M2GTR](#)
[DMN31D5UDJ-7](#) [DMP22D4UFO-7B](#) [DMN1006UCA6-7](#) [DMN16M9UCA6-7](#) [STF5N65M6](#) [IRF40H233XTMA1](#) [STU5N65M6](#)
[DMN6022SSD-13](#) [DMN13M9UCA6-7](#) [DMTH10H4M6SPS-13](#) [DMN2990UFB-7B](#) [IPB80P04P405ATMA2](#) [2N7002W-G](#) [MCAC30N06Y-](#)
[TP](#) [MCQ7328-TP](#) [NTMC083NP10M5L](#) [NVMFS2D3P04M8LT1G](#) [BXP7N65D](#) [BXP4N65F](#) [AOL1454G](#) [WMJ80N60C4](#) [BXP2N20L](#)
[BXP2N65D](#) [BXT1150N10J](#) [BXT1700P06M](#) [TSM60NB380CP](#) [ROG](#) [RQ7L055BGTCR](#) [DMNH15H110SK3-13](#)