

Product Summary

$V_{(BR)DSS}$	$R_{DS(on)TYP}$	I_D
40V	0.65mΩ@10V	350A
	1mΩ@4.5V	

Feature

- Fast Switching
- Low Gate Charge and R_{ds(on)}
- Advanced Split Gate Trench Technology
- 100% Single Pulse avalanche energy Test

Applications

- PWM Application
- Hard switched and high frequency circuits
- Power Management

Package

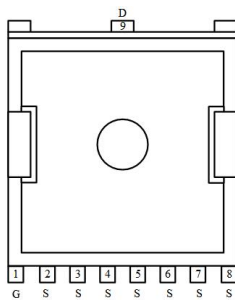

Toll

Circuit diagram

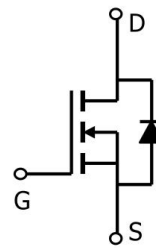

Marking

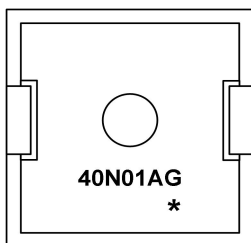

40N01AG =Device Code
* =Month Code

Absolute maximum ratings (Ta=25°C, unless otherwise noted)

Parameter	Symbol	Rating	Units
Drain-Source Voltage	V_{DS}	40	V
Gate-Source Voltage	V_{GS}	± 20	V
Continuous Drain Current (Tc=25°C)	I_D	350	A
Pulsed Drain Current	I_{DM}	1400	A
Single Pulse Avalanche Energy ¹	E_{AS}	1458	mJ
Total Power Dissipation ² (Tc=25°C)	P_D	500	W
Thermal Resistance Junction-Case	$R_{\theta JC}$	0.25	°C/W
Storage Temperature Range	T_{STG}	-55 to 150	°C
Operating Junction Temperature Range	T_J	-55 to 150	°C

Electrical characteristics (Ta=25°C, unless otherwise noted)

Parameter	Symbol	Conditions	Min.	Typ.	Max.	Unit
Static Characteristics						
Drain-Source Breakdown Voltage	BV_{DSS}	$V_{GS}=0V, I_D=250\mu A$	40	---	---	V
Drain-Source Leakage Current	I_{DSS}	$V_{DS}=32V, V_{GS}=0V, T_J=25^\circ C$	---	---	1	μA
Gate-Source Leakage Current	I_{GSS}	$V_{GS}=\pm 20V, V_{DS}=0V$	---	---	± 100	nA
Gate Threshold Voltage	$V_{GS(th)}$	$V_{GS}=V_{DS}, I_D=250\mu A$	1	1.8	2.5	V
Static Drain-Source On-Resistance	$R_{DS(on)}$	$V_{GS}=10V, I_D=50A$	---	0.65	0.82	m Ω
		$V_{GS}=4.5V, I_D=35A$	---	1	1.35	
Dynamic characteristics						
Input Capacitance	C_{iss}	$V_{DS}=20V, V_{GS}=0V, f=1MHz$	---	11665	---	pF
Output Capacitance	C_{oss}		---	4644	---	
Reverse Transfer Capacitance	C_{rss}		---	142	---	
Switching Characteristics						
Total Gate Charge (4.5V)	Q_g	$V_{DS}=20V, V_{GS}=10V, I_D=20A$	---	178		nC
Gate-Source Charge	Q_{gs}		---	59		
Gate-Drain Charge	Q_{gd}		---	17		
Turn-On Delay Time	$T_{d(on)}$	$V_{DD}=20V, V_{GS}=10V, R_G=1.6\Omega, I_D=20A$	---	26.5	---	ns
Rise Time	T_r		---	13.8	---	
Turn-Off Delay Time	$T_{d(off)}$		---	112	---	
Fall Time	T_f		---	16.6	---	
Diode Characteristics						
Diode Forward Voltage ²	V_{SD}	$V_{GS}=0V, I_S=1A, T_J=25^\circ C$	---	---	1.2	V

Note :

- The EAS data shows Max. rating . The test condition is $V_{DD}=20V, V_{GS}=10V, L=0.5mH, R_G=25\Omega$
- The power dissipation is limited by 150°C junction temperature

Typical Characteristics

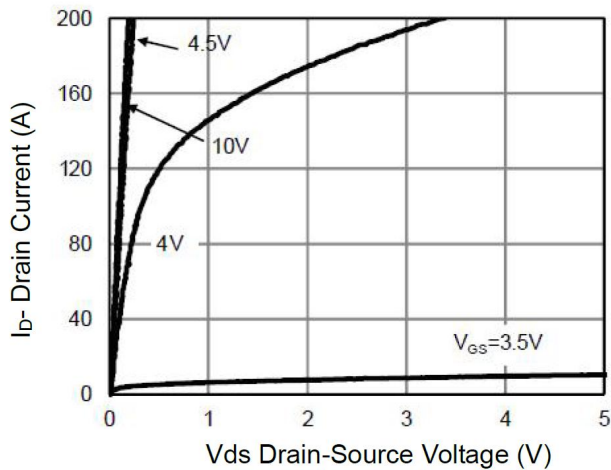

Output Characteristics

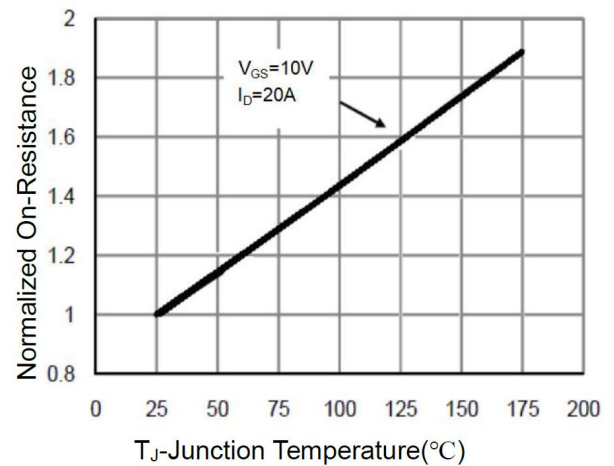

Rdson-Junction Temperature

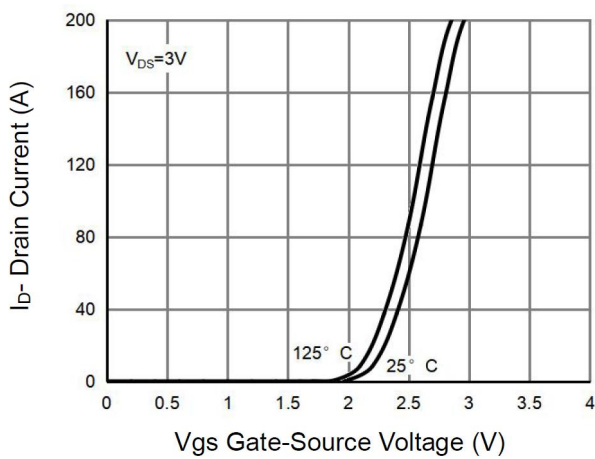

Transfer Characteristics

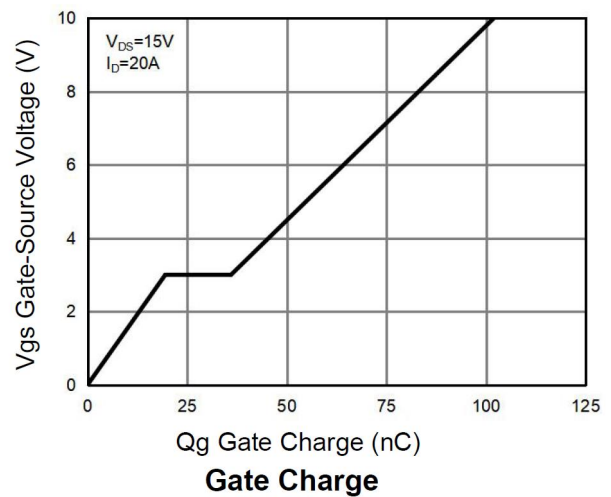

Gate Charge

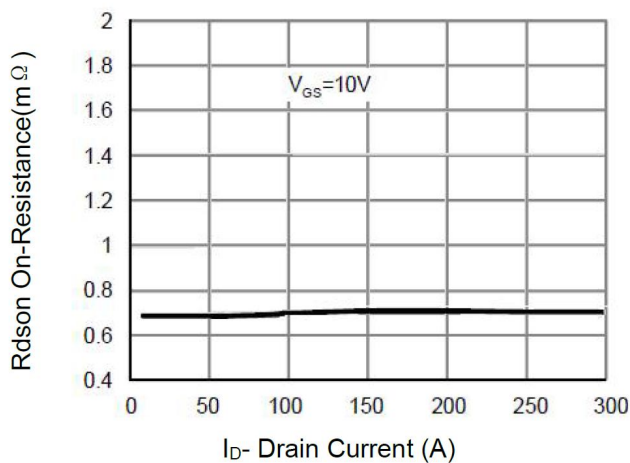

Rdson- Drain Current

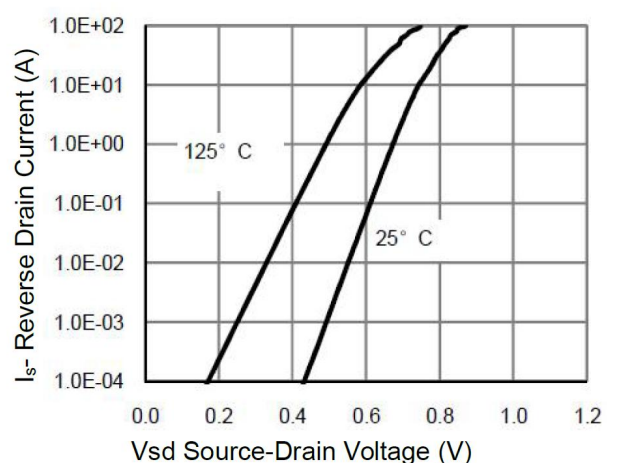

Source- Drain Diode Forward

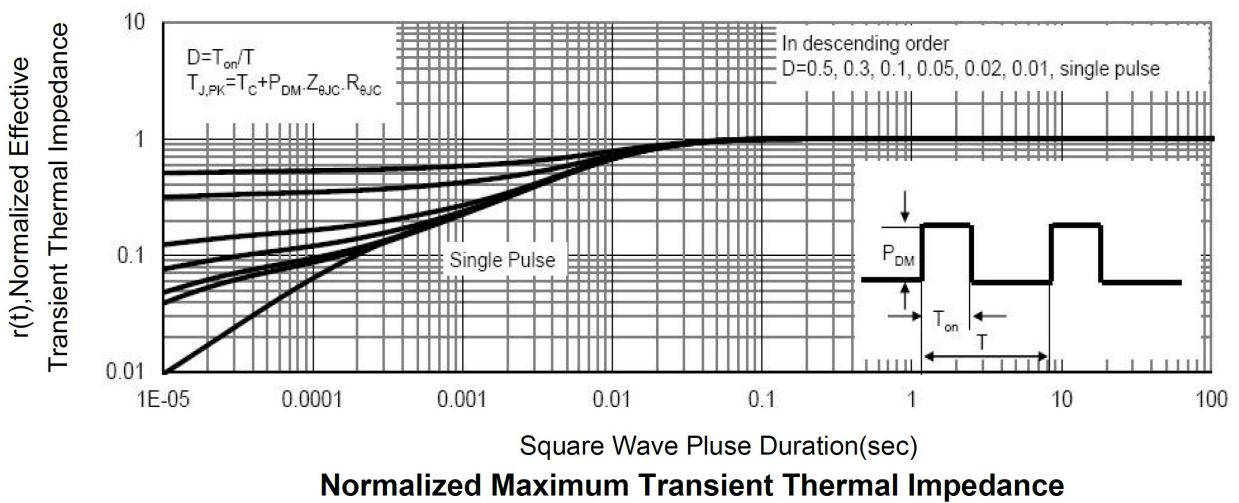
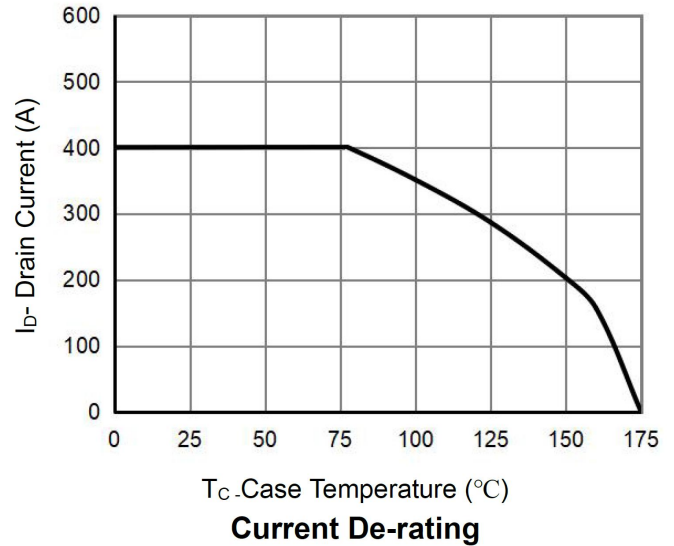
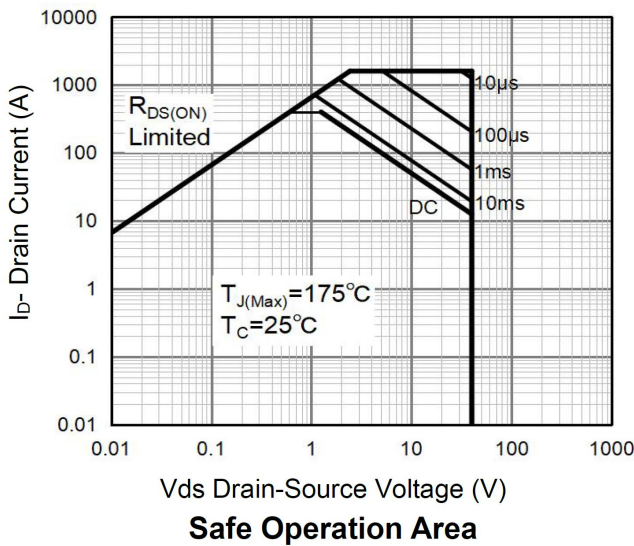
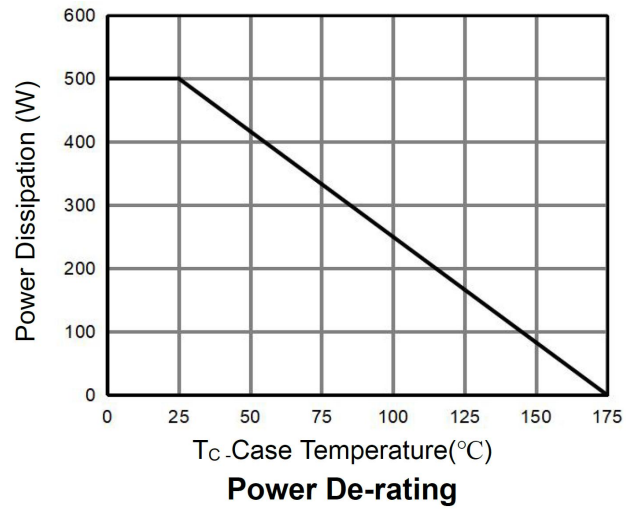
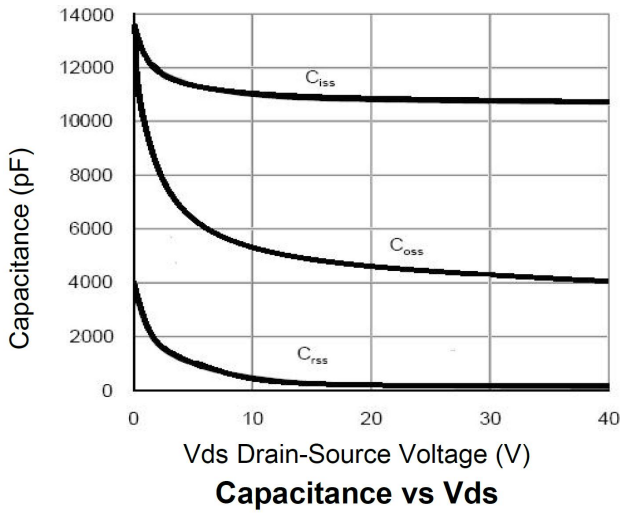



TOLL Package Information

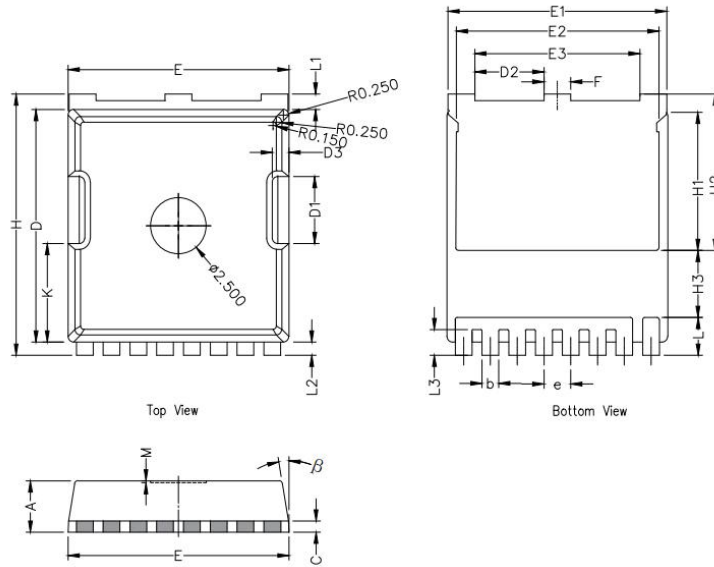

Symbol	Dimensions In Millimeters		
	Min.	Nom.	Max.
A	2.20	2.30	2.40
b	0.65	0.75	0.85
C	0.508 REF		
D	10.25	10.40	10.55
D1	2.85	3.00	3.15
E	9.75	9.90	10.05
E1	9.65	9.80	9.95
E2	8.95	9.10	9.25
E3	7.25	7.40	7.55
e	1.20 BSC		
F	1.05	1.20	1.35
H	11.55	11.70	11.85
H1	6.03	6.18	6.33
H2	6.85	7.00	7.15
H3	3.00 BSC		
L	1.55	1.70	1.85
L1	0.55	0.7	0.85
L2	0.45	0.6	0.75
M	0.08 REF.		
β	8°	10°	12°
K	4.25	4.40	4.55

X-ON Electronics

Largest Supplier of Electrical and Electronic Components

Click to view similar products for [MOSFET](#) category:

Click to view products by [Siliup](#) manufacturer:

Other Similar products are found below :

[IRFD120](#) [IRFY240C](#) [JANTX2N5237](#) [2SK2267\(Q\)](#) [BUK455-60A/B](#) [MIC4420CM-TR](#) [VN1206L](#) [NDP4060](#) [SI4482DY](#)
[IPS70R2K0CEAKMA1](#) [SQD23N06-31L-GE3](#) [TK16J60W,S1VQ\(O](#) [2SK2614\(TE16L1,Q\)](#) [DMN1017UCP3-7](#) [EFC2J004NUZTDG](#)
[DMN1053UCP4-7](#) [SQJ469EP-T1-GE3](#) [NTE2384](#) [DMC2700UDMQ-7](#) [DMN2080UCB4-7](#) [DMN61D9UWQ-13](#) [US6M2GTR](#)
[DMN31D5UDJ-7](#) [DMP22D4UFO-7B](#) [DMN1006UCA6-7](#) [DMN16M9UCA6-7](#) [STF5N65M6](#) [IRF40H233XTMA1](#) [STU5N65M6](#)
[DMN6022SSD-13](#) [DMN13M9UCA6-7](#) [DMTH10H4M6SPS-13](#) [DMN2990UFB-7B](#) [IPB80P04P405ATMA2](#) [2N7002W-G](#) [MCAC30N06Y-](#)
[TP](#) [MCQ7328-TP](#) [NTMC083NP10M5L](#) [NVMFS2D3P04M8LT1G](#) [BXP7N65D](#) [BXP4N65F](#) [AOL1454G](#) [WMJ80N60C4](#) [BXP2N20L](#)
[BXP2N65D](#) [BXT1150N10J](#) [BXT1700P06M](#) [TSM60NB380CP](#) [ROG](#) [RQ7L055BGTCR](#) [DMNH15H110SK3-13](#)