

160V Half-Bridge Driver

PRODUCT SUMMARY

- V_{OFFSET} 160 V max.
- $I_{\text{O}+/-}$ 1A/1.5A
- V_{OUT} 10 V - 20 V
- $t_{\text{on/off}}$ (typ.) 150 ns/150 ns
- **Deadtime** (typ.) 110 ns

GENERAL DESCRIPTION

The SLM2009 is a high voltage, high speed power MOSFET and IGBT drivers with dependent high- and low-side referenced output channels. Proprietary HVIC and latch immune CMOS technologies enable ruggedized monolithic construction. The logic input is compatible with standard CMOS or LSTTL output, down to 3.3 V logic. The output drivers feature a high pulse current buffer stage designed for minimum driver cross conduction. The floating channel can be used to drive an N-channel power MOSFET or IGBT in the high-side configuration which operates up to 160 V.

FEATURES

- Floating channel designed for bootstrap operation
- Fully operational to +160 V
- Tolerant to negative transient voltage, dV/dt immune
- Gate drive supply range from 10 V to 20 V
- Under-voltage lockout
- 3.3 V, 5 V logic compatible
- Cross-conduction prevention logic
- Matched propagation delay for both channels
- Internal set deadtime
- High-side output in phase with $\overline{\text{HIN}}$ input
- Low-side output out of phase with $\overline{\text{LIN}}$ input
- RoHS compliant
- SOIC-8 package

TYPICAL APPLICATION CIRCUIT

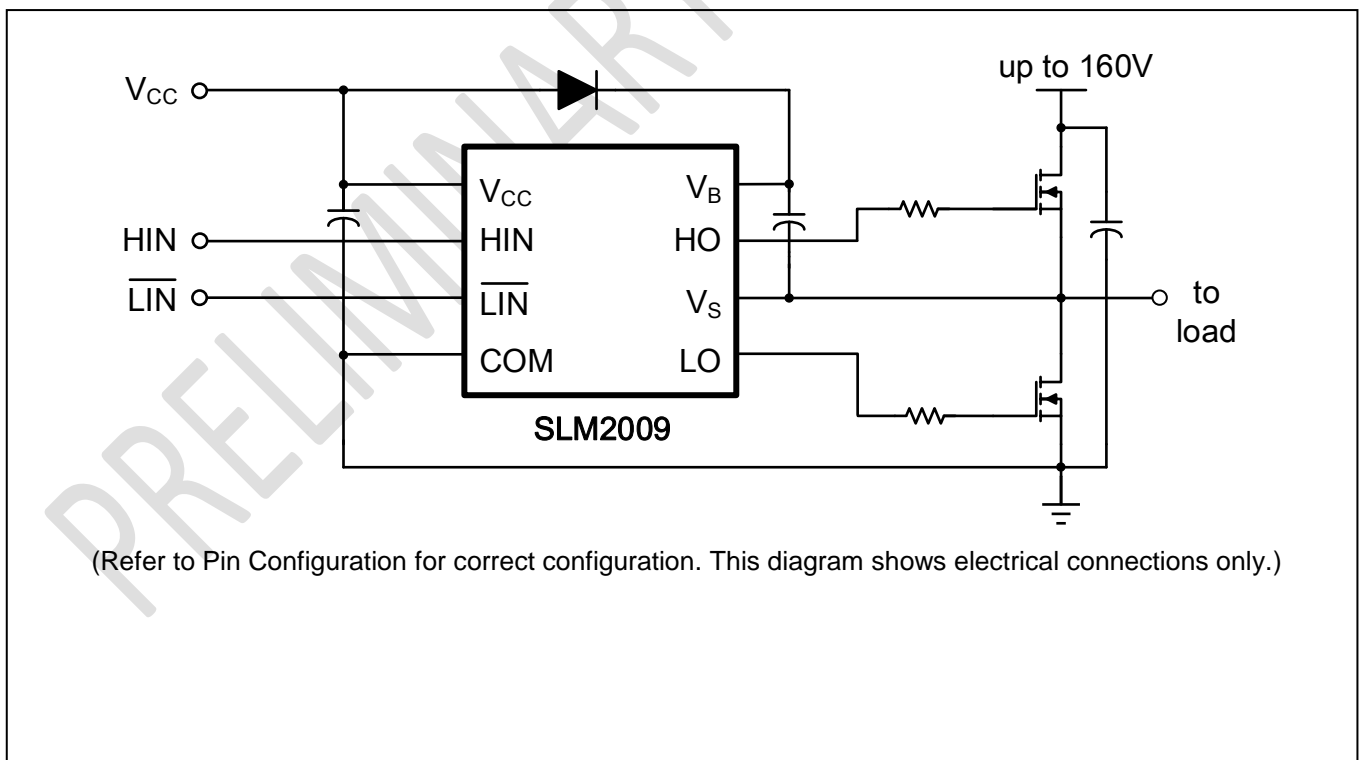

Table of Contents

Product Summary	1
General Description	1
Features	1
Typical Application Circuit.....	1
PIN Configuration.....	3
PIN Description.....	3
Ordering Information.....	3
Functional Block Diagram	4
Absolute Maximum Ratings	5
Recommended Operation Conditions	5
Dynamic Electrical Characteristics	6
Static Electrical Characteristics.....	6
Package Case Outlines	8
Revision History.....	9

PRELIMINARY DATASHEET

PIN CONFIGURATION

Package	Pin Configuration (Top View)
SOIC-8	

PIN DESCRIPTION

No.	Pin	Description
1	V _{CC}	Low-side and logic fixed supply
2	HIN	Logic input for high-side gate driver output (HO), in phase
3	$\overline{\text{LIN}}$	Logic input for low-side gate driver output (LO), out of phase
4	COM	Low-side return
5	LO	Low-side gate drive output
6	V _S	High-side floating supply return
7	HO	High-side gate drive output
8	V _B	High-side floating supply

ORDERING INFORMATION

Industrial Range: -40°C to +125°C

Order Part No.	Package	QTY
SLM2009CA-DG	SOIC8, Pb-Free	4000/Reel

FUNCTIONAL BLOCK DIAGRAM

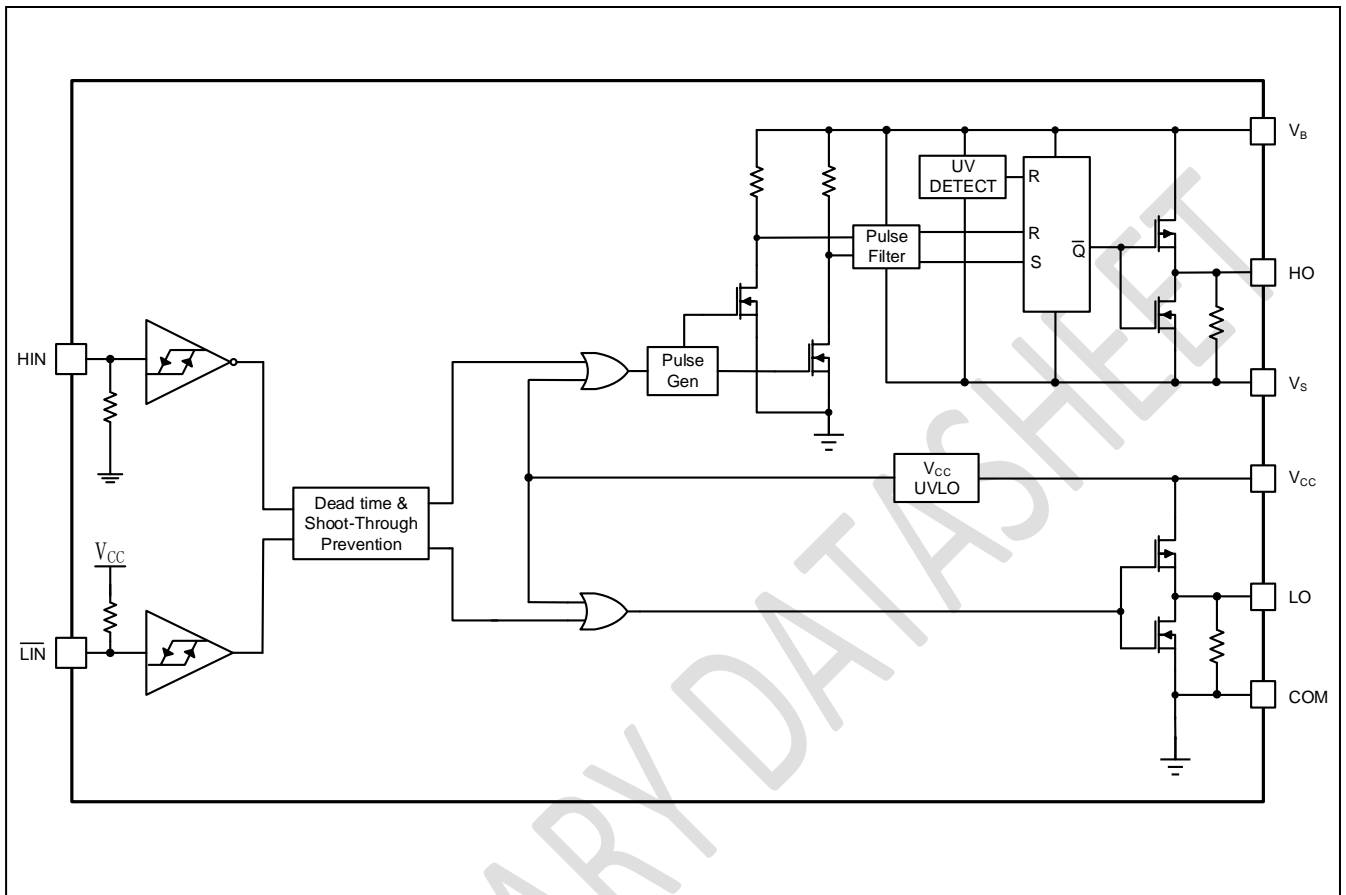

ABSOLUTE MAXIMUM RATINGS

Symbol	Definition	Min.	Max.	Units
V_B	High-side floating absolute voltage	-0.3	185	V
V_S	High-side floating supply offset voltage	$V_B - 25$	$V_B + 0.3$	
V_{HO}	High-side floating output voltage	$V_S - 0.3$	$V_B + 0.3$	
V_{CC}	Low-side and logic fixed supply voltage	-0.3	25	
V_{LO}	Low-side output voltage	-0.3	$V_{CC} + 0.3$	
V_{IN}	Logic input voltage (HIN & LIN)	-0.3	10	
dV_S/dt	Allowable offset supply voltage transient	---	50	V/ns
P_D	Package power dissipation at $T_A \leq +25^\circ\text{C}$	---	0.625	W
θ_{JA}	Thermal resistance, junction to ambient	---	200	$^\circ\text{C}/\text{W}$
T_J	Junction temperature	---	150	$^\circ\text{C}$
T_S	Storage temperature	-55	150	
T_L	Lead temperature (soldering, 10 seconds)	---	300	

Note: Absolute maximum ratings indicate sustained limits beyond which damage to the device may occur. All voltage parameters are absolute voltages referenced to COM. The thermal resistance and power dissipation ratings are measured under board mounted and still air conditions.

RECOMMENDED OPERATION CONDITIONS

Symbol	Definition	Min.	Max.	Units
V_B	High-side floating absolute voltage	$V_S + 10$	$V_S + 20$	V
V_S	High-side floating supply offset voltage		160	
V_{HO}	High-side floating output voltage	V_S	V_B	
V_{CC}	Low-side and logic fixed supply voltage	10	20	
V_{LO}	Low-side output voltage	0	V_{CC}	
V_{IN}	Logic input voltage (HIN & LIN)	0	10	
T_A	Ambient temperature	-40	125	$^\circ\text{C}$

Note: For proper operation the device should be used within the recommended conditions. The V_S offset rating is tested with all supplies biased at a 15 V differential.

DYNAMIC ELECTRICAL CHARACTERISTICS

V_{BIAS} (V_{CC} , V_{BS}) = 15 V, C_L = 1000 pF and T_A = 25°C unless otherwise specified.

Symbol	Parameter	Condition	Min.	Typ.	Max.	Unit
t_{on}	Turn-on propagation delay	$V_S = 0$ V	---	150	260	ns
t_{off}	Turn-off propagation delay	$V_S = 0$ V	---	150	260	
t_r	Turn-on rise time		---	20	50	
t_f	Turn-off fall time		---	10	25	
DT	Deadtime, LS turn-off to HS turn-on & HS turn-on to LS turn-off		50	110	220	
MT	Delay matching, HS & LS turn-on/off		---	---	60	

Note: See timing diagram in Figure 1, Figure 2, Figure 3 and Figure 4.

STATIC ELECTRICAL CHARACTERISTICS

V_{BIAS} (V_{CC} , V_{BS}) = 15 V and T_A = 25°C unless otherwise specified. The V_{IN} , V_{TH} , and I_{IN} parameters are referenced to COM. The V_O and I_O parameters are referenced to COM and are applicable to the respective output leads: HO or LO.

Symbol	Parameter	Condition	Min.	Typ.	Max.	Unit
V_{IH}	Logic "1" (HIN) & Logic "0" (\overline{LIN}) input voltage	$V_{CC} = 10$ V to 20V	2.5	---	---	V
V_{IL}	Logic "0" (HIN) & Logic "1" (\overline{LIN}) input voltage		---	---	0.8	
V_{OH}	High level output voltage, $V_{BIAS} - V_O$	$I_O = 20$ mA	---	0.2	1	
V_{OL}	Low level output voltage, V_O		---	0.07	0.5	
I_{LK}	Offset supply leakage current	$V_B = V_S = 160$ V	---	---	50	μ A
I_{QBS}	Quiescent V_{BS} supply current	$V_O = 0$ V	---	60	75	
I_{QCC}	Quiescent V_{CC} supply current		---	142	350	
I_{IN+}	Logic "1" input bias current on HIN	HIN = 5 V	---	100	150	
	Logic "1" input bias current on \overline{LIN}	$\overline{LIN} = 0$ V	---	---	80	
I_{IN-}	Logic "0" input bias current on HIN	HIN = 0 V	---	---	5	
	Logic "0" input bias current on \overline{LIN}	$\overline{LIN} = 5$ V	---	---	-80	

Symbol	Parameter	Condition	Min.	Typ.	Max.	Unit
V_{CCUV+}	V_{CC} supply under-voltage positive going threshold		8	8.9	9.8	V
V_{CCUV-}	V_{CC} supply under-voltage negative going threshold		7.4	8.2	9	
V_{BSUV+}	V_{BS} supply under-voltage positive going threshold			4.8		
V_{BSUV-}	V_{BS} supply under-voltage negative going threshold			4.3		
I_{O+}	Output high short circuit pulsed current	$V_O = 0\text{ V}$, $V_{IN} = V_{IH}$ $PW \leq 10\ \mu\text{s}$		1		A
I_{O-}	Output low short circuit pulsed current	$V_O = 15\text{ V}$, $V_{IN} = V_{IL}$ $PW \leq 10\ \mu\text{s}$		1.5		

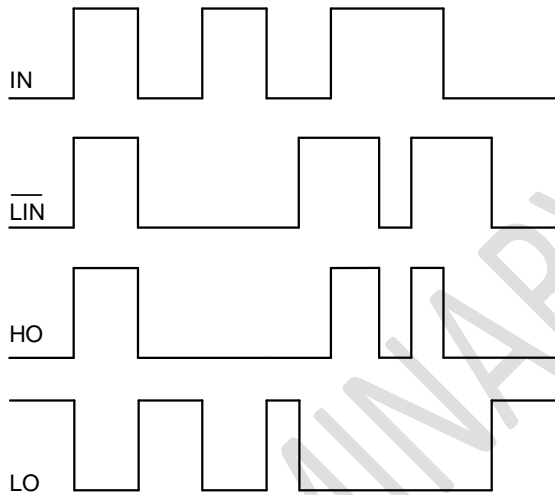

Figure 1. Input/Output Timing Diagram

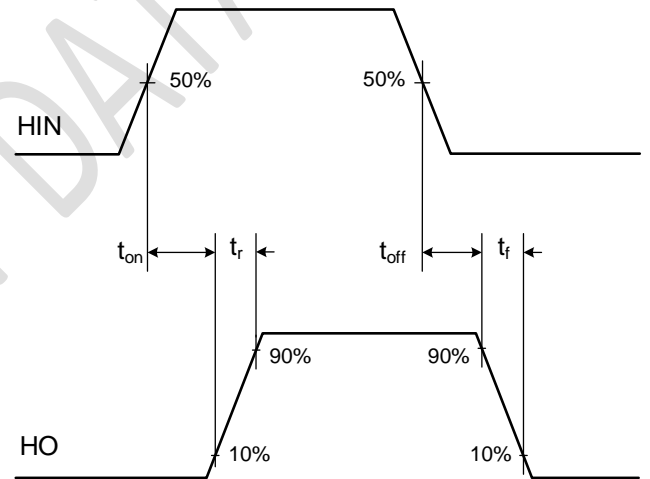

Figure 2. High Side Switching Time Waveform

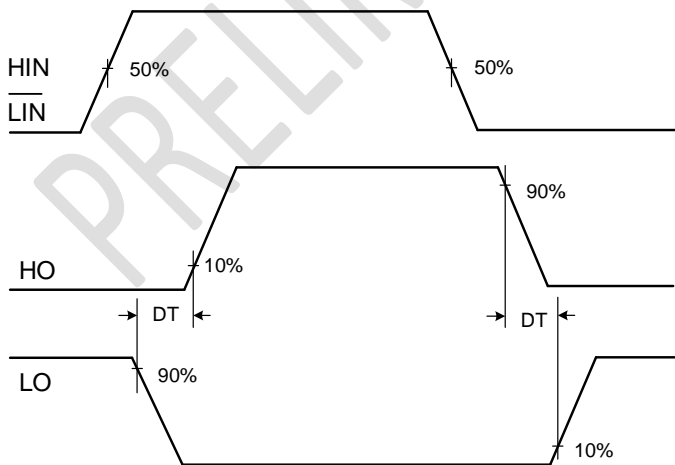

Figure 3. Dead Time Waveform

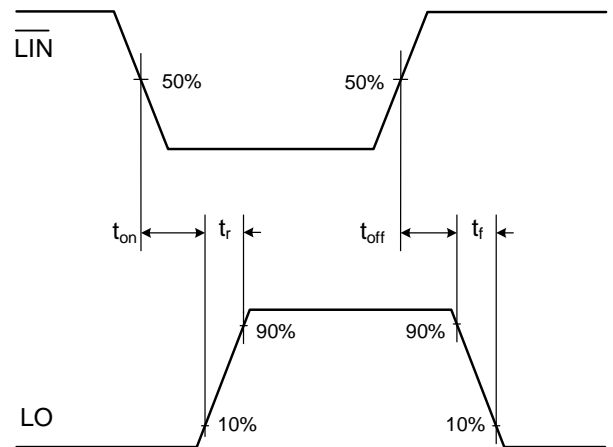

Figure 4. Low Side Switching Time Waveform

PACKAGE CASE OUTLINES

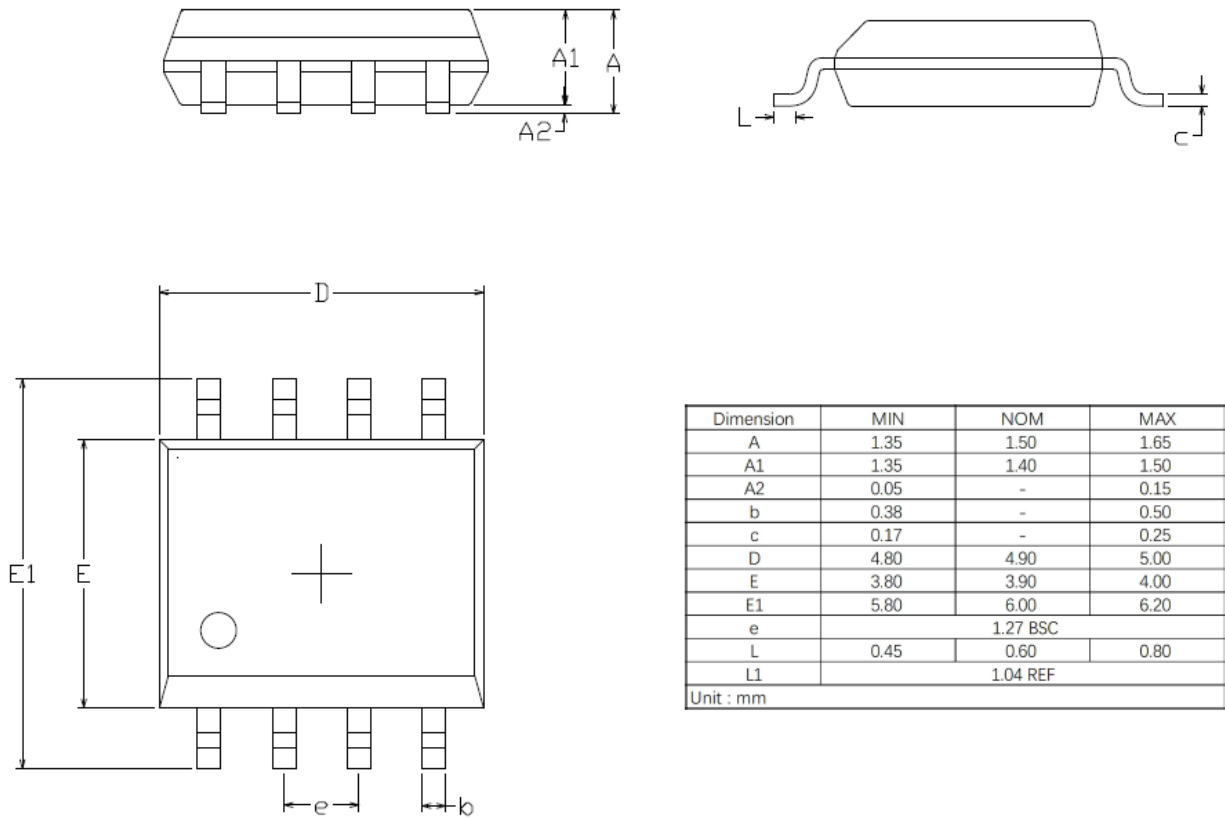

Figure 5. SOIC8 Outline Dimensions

REVISION HISTORY

Note: page numbers for previous revisions may differ from page numbers in current version

Page or Item	Subjects (major changes since previous revision)
Rev 0.1 preliminary datasheet 2021-08-06	
Whole document	Rev 0.1 preliminary datasheet release

PRELIMINARY DATASHEET

X-ON Electronics

Largest Supplier of Electrical and Electronic Components

Click to view similar products for [Gate Drivers](#) category:

Click to view products by [Sillumin](#) manufacturer:

Other Similar products are found below :

[00053P0231](#) [56956](#) [57.404.7355.5](#) [LT4936](#) [57.904.0755.0](#) [5811-0902](#) [5882900001](#) [00600P0005](#) [00-9050-LRPP](#) [00-9090-RDPP](#)
[5951900000](#) [0131700000](#) [00-2240](#) [LTP70N06](#) [LVP640](#) [5J0-1000LG-SIL](#) [LY2-US-AC240](#) [LY3-UA-DC24](#) [00576P0020](#) [00600P0010](#)
[LZN4-UA-DC12](#) [LZNQ2M-US-DC5](#) [LZNQ2-US-DC12](#) [LZP40N10](#) [00-8196-RDPP](#) [00-8274-RDPP](#) [00-8275-RDNP](#) [00-8609-RDPP](#) [00-](#)
[8722-RDPP](#) [00-8728-WHPP](#) [00-8869-RDPP](#) [00-9051-RDPP](#) [00-9091-LRPP](#) [00-9291-RDPP](#) [0207100000](#) [0207400000](#) [60100564](#) [60249-1-](#)
[CUT-TAPE](#) [0134220000](#) [60713816](#) [M15730061](#) [61161-90](#) [61278-0020](#) [6131-204-23149P](#) [6131-205-17149P](#) [6131-209-15149P](#) [6131-218-](#)
[17149P](#) [6131-220-21149P](#) [6131-260-2358P](#) [6131-265-11149P](#)