

600V Three-Phase Bridge Driver with OCP, Enable and Fault

PRODUCT SUMMARY

- V_{OFFSET} 600 V max.
- $I_{\text{O}+/-}$ 200 mA / 350 mA
- V_{OUT} 10V - 20 V
- $t_{\text{on/off}}$ (typ.) 350 ns / 400 ns
- **Deadtime (typ.)** 290 ns

FEATURES

- Floating channel designed for bootstrap operation
- Fully operational to +600 V
- Tolerant to negative transient voltage, dV/dt immune
- Gate drive supply range from 10 V to 20 V
- Undervoltage lockout for all channels
- Low/high side output in phase with inputs
- 3.3 V, 5 V logic compatible
- Lower di/dt gate drive for better noise immunity
- Cross-conduction prevention logic
- Matched propagation delay for both channels
- Externally programmable delay for automatic fault clear
- SOP28W package

GENERAL DESCRIPTION

The SLM21364 is a high voltage, high speed power MOSFET and IGBT drivers with three independent high- and low-side referenced output channels for three-phase applications. Proprietary HVIC and latch immune CMOS technologies enable ruggedized monolithic construction. The logic inputs are compatible with standard CMOS or LSTTL output, down to 3.3 V logic. A current trip function which terminates all six outputs can be derived from an external current sense resistor. An enable function is available to terminate all six outputs simultaneously. An open-drain FAULT signal is provided to indicate that an overcurrent or undervoltage shutdown has occurred. Overcurrent fault conditions are cleared automatically after a delay programmed externally via an RC network connected to the RCIN input. The output drivers feature a high pulse current buffer stage designed for minimum driver cross conduction. Propagation delays are matched to simplify use in high frequency applications. The floating channel can be used to drive an N-channel power MOSFET or IGBT in the high-side configuration which operates up to 600 V.

TYPICAL APPLICATION CIRCUIT

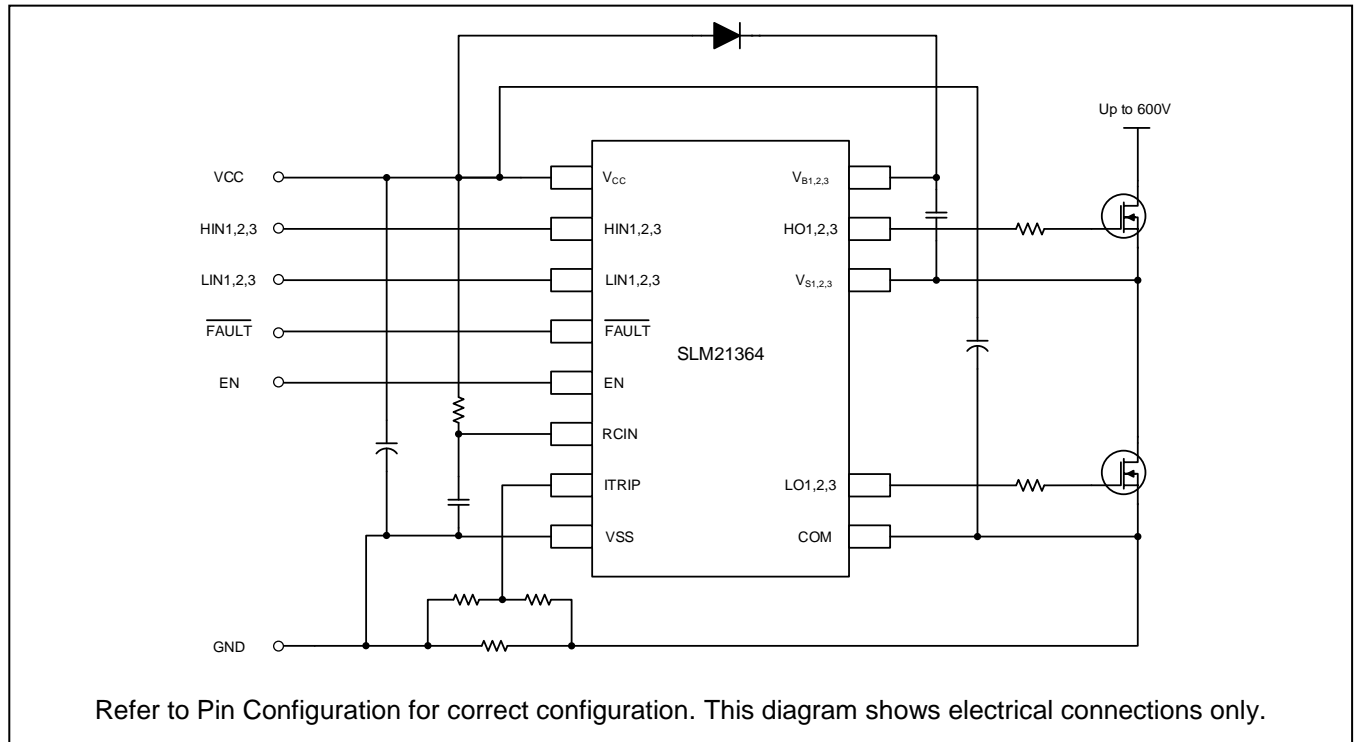

Table of Contents

Product Summary	1
Features	1
General Description	1
Typical Application Circuit	1
PIN Configuration	3
PIN Description	3
Ordering Information	4
Functional Block Diagram	5
Absolute Maximum Ratings	6
Recommended Operation Conditions	6
Dynamic Electrical Characteristics	7
Static Electrical Characteristics	7
Functional Table	9
Typical Performance Characteristics	12
Package Case Outlines	15
Revision History	16

PIN CONFIGURATION

Package	Pin Configuration (Top View)
SOP28W	

PIN DESCRIPTION

No.	Pin	Description
1	V _{CC}	Low-side and logic supply voltage.
2, 3, 4	HIN _{1,2,3}	Logic input for high-side gate driver output (HO _{1,2,3}), in phase.
5, 6, 7	LIN _{1,2,3}	Logic input for low-side gate driver output (LO _{1,2,3}), in phase.
8	$\overline{\text{FAULT}}$	Indicates over-current (ITRIP) or low-side undervoltage lockout has occurred. Negative logic, open-drain output.
9	ITRIP	Analog input for overcurrent shutdown. When active, ITRIP shuts down outputs and activates FAULT and RCIN low. When ITRIP becomes inactive, FAULT stays active low for an externally set time, T _{FLTCLR} , then automatically becomes inactive (open-drain high impedance).
10	EN	Logic input to enable I/O functionality. I/O logic functions when EN is high. No effect on FAULT and not latched.
11	RCIN	External RC network input used to define FAULT CLEAR delay, T _{FLTCLR} , approximately equal to R*C. When RCIN>8 V, the FAULT pin goes back into open-drain high-impedance.
12	V _{SS}	Logic ground.
13	COM	Low-side gate drivers return.
14, 15, 16	LO _{1, 2, 3}	Low-side gate driver outputs.
18, 22, 26	V _{S1, 2, 3}	High-side floating supply return.
19, 23, 27	HO _{1, 2, 3}	High-side gate driver outputs.
20, 24, 28	V _{B1, 2, 3}	High-side floating supply.

ORDERING INFORMATION

Industrial Range: -40°C to +125°C

Order Part No.	Package	QTY
SLM21364CF-DG	SOP28W, Pb-Free	1000/Reel

FUNCTIONAL BLOCK DIAGRAM

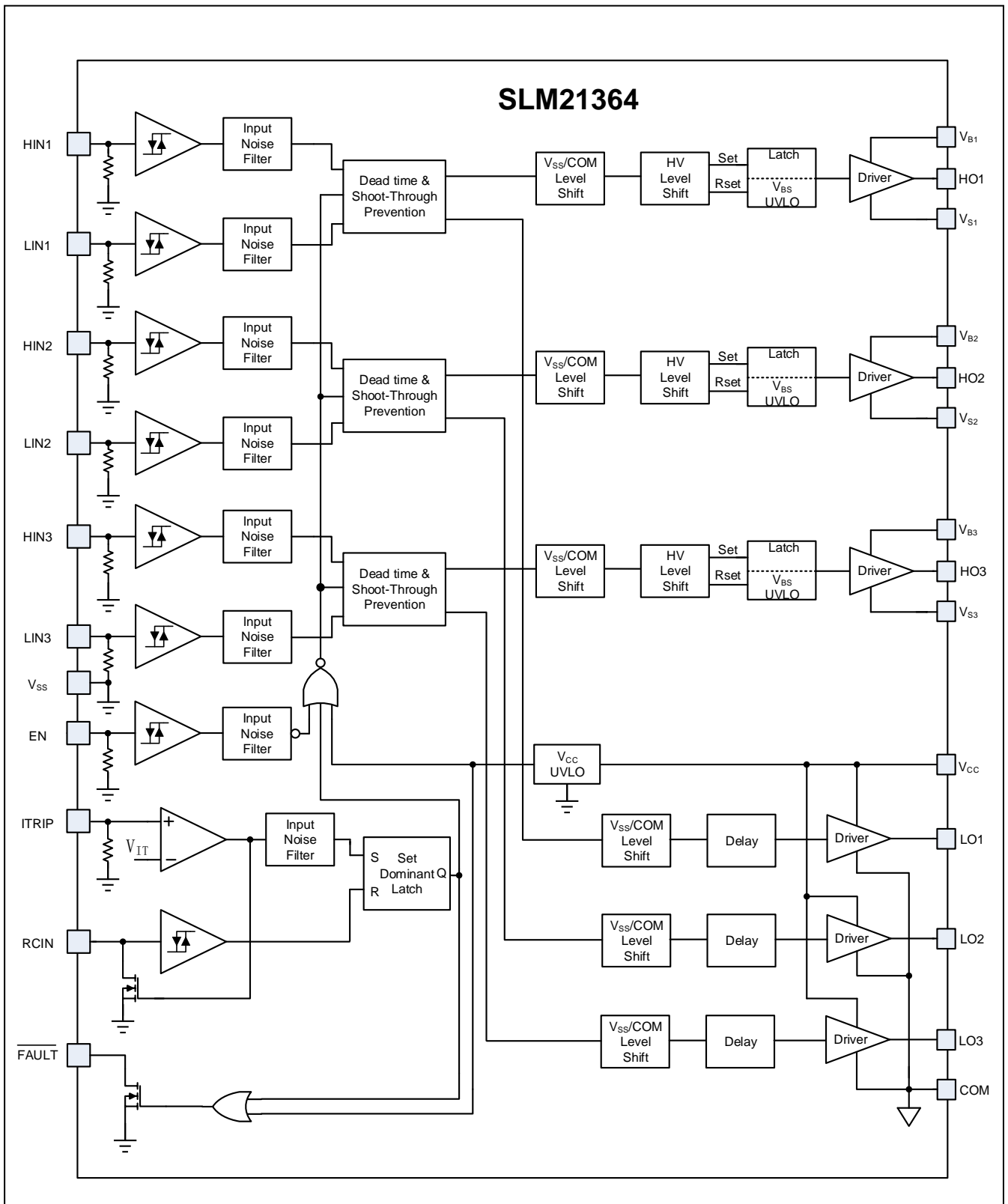

ABSOLUTE MAXIMUM RATINGS

Symbol	Definition	Min.	Max.	Units
V _B	High-side floating absolute voltage	-0.3	625	V
V _S	High-side floating supply offset voltage	V _{B1,2,3} - 25	V _{B1,2,3} + 0.3	
V _{HO}	High-side floating output voltage	V _{S1,2,3} - 0.3	V _{B1,2,3} + 0.3	
V _{CC}	Low-side and logic supply voltage	-0.3	25	
V _{SS}	Logic ground	-5	+ 5	
V _{IN}	Logic input voltage (LIN, HIN, ITRIP, EN)	V _{SS} - 0.3	Lower of (V _{SS} + 15) or (V _{CC} + 0.3)	
V _{LO1,2,3}	Low-side output voltage	-0.3	V _{CC} + 0.3	
V _{RCIN}	RCIN input voltage	V _{SS} - 0.3	V _{CC} + 0.3	
V _{FLT}	$\overline{\text{FAULT}}$ output voltage	V _{SS} - 0.3	Lower of (V _{SS} + 25) or (V _{CC} + 0.3)	
dV _S /dt	Allowable offset supply voltage transient	---	50	
P _D	Package power dissipation @ T _A ≤ +25°C	---	1.6	W
θ _{JA}	Thermal resistance, junction to ambient	---	75	°C/W
T _J	Junction temperature	---	150	°C
T _S	Storage temperature	-55	150	
T _L	Lead temperature (soldering, 10 seconds)	---	300	

Note: Absolute maximum ratings indicate sustained limits beyond which damage to the device may occur. All voltage parameters are absolute voltages referenced to COM. The thermal resistance and power dissipation ratings are measured under board mounted and still air conditions.

RECOMMENDED OPERATION CONDITIONS

The input/output logic timing diagram is shown in Figure 1. For proper operation the device should be used within the recommended conditions. The V_S offset rating is tested with all supplies biased at a 15 V differential.

Symbol	Definition	Min.	Max.	Units
V _{B1,2,3}	High-side floating supply voltage	V _{S1,2,3} + 10	V _{S1,2,3} + 20	V
V _{S1,2,3}	High-side floating supply offset voltage		600	
V _{HO1,2,3}	High-side floating output voltage	V _{S1,2,3}	V _{B1,2,3}	
V _{LO1,2,3}	Low-side output voltage	0	V _{CC}	
V _{CC}	Low-side and logic fixed supply voltage	10	20	
V _{SS}	Logic ground	-5	5	
V _{FLT}	$\overline{\text{FAULT}}$ output voltage	V _{SS}	V _{CC}	
V _{RCIN}	RCIN input voltage	V _{SS}	V _{CC}	
V _{ITRIP}	ITRIP input voltage	V _{SS}	V _{SS} + 20V	
V _{IN}	Logic input voltage LIN1,2,3, HIN1,2,3, EN	V _{SS}	V _{SS} + 20V	
T _A	Ambient temperature	- 40	125	°C

Note: Logic operational for V_S of (COM - 5 V) to (COM + 600V). Logic state held for V_S of (COM-5V) to (COM - V_{BS}).

DYNAMIC ELECTRICAL CHARACTERISTICS
 $V_{BIAS} (V_{CC}, V_{BS}) = 15\text{ V}$, $V_{S1,2,3} = V_{SS} = \text{COM}$, $C_L = 1000\text{ pF}$ and $T_A = 25^\circ\text{C}$ unless otherwise specified.

Symbol	Parameter	Condition	Min.	Typ.	Max.	Unit
t_{on}	Turn-on propagation delay	$V_S = 0\text{ V}$	200	350	500	ns
t_{off}	Turn-off propagation delay	$V_S = 600\text{ V}$	250	400	550	
t_r	Turn-on rise time		---	100	150	
t_f	Turn-off fall time		---	40	70	
t_{EN}	Enable low to output shutdown propagation delay	$V_{IN}, V_{EN} = 0\text{ V or }5\text{ V}$	300	400	500	
t_{ITRIP}	ITRIP to output shutdown propagation delay	$V_{ITRIP} = 5\text{ V}$	450	650	850	
t_{bl}	ITRIP blanking time	$V_{IN} = 0\text{ V or }5\text{ V}$ $V_{ITRIP} = 5\text{ V}$	100	150	---	
t_{FLT}	ITRIP to $\overline{\text{FAULT}}$ propagation delay	$V_{IN} = 0\text{ V or }5\text{ V}$ $V_{ITRIP} = 5\text{ V}$	400	600	800	
t_{FILIN}	Input filter time (HIN, LIN)	$V_{IN} = 0\text{ V \& }5\text{ V}$	200	300	---	
t_{FLTCLR}	FAULT clear time RCIN: R = 2 M Ω , C = 1nF	$V_{IN} = 0\text{ V or }5\text{ V}$ $V_{ITRIP} = 0\text{ V}$	1.3	1.65	2	ms
DT	Deadtime, LS turn-off to HS turn-on & HS turn-on to LS turn-off	$V_{IN} = 0\text{ V \& }5\text{ V}$	200	290	450	ns
MT	Matching delay, HS & LS turn-on/off	External dead time > 400 ns	---	---	100	
PM	Output pulse width matching ($PW_{IN} - PW_{OUT}$) (Figure 2)		---	50	75	

STATIC ELECTRICAL CHARACTERISTICS
 $V_{BIAS} (V_{CC}, V_{BS1,2,3}) = 15\text{ V}$ and $T_A = 25^\circ\text{C}$ unless otherwise specified. The V_{IN} , V_{TH} , and I_{IN} parameters are referenced to V_{SS} and are applicable to all 6 channels (LIN1,2,3 and HIN1,2,3). The V_O and I_O parameters are referenced to COM and $V_{S1,2,3}$ and are applicable to the respective output leads: HO1,2,3 and LO1,2,3.

Symbol	Parameter	Condition	Min.	Typ.	Max.	Unit
V_{IH}	Logic "1" input voltage (LIN1,2,3 and HIN1,2,3)	$V_{CC} = 10\text{ V to }20\text{ V}$	2.5	---	---	V
V_{IL}	Logic "0" input voltage (LIN1,2,3 and HIN1,2,3)		---	---	0.8	
$V_{EN, TH+}$	Enable positive going threshold		---	---	2.5	
$V_{EN, TH-}$	Enable negative going threshold		0.8	---	---	

Symbol	Parameter	Condition	Min.	Typ.	Max.	Unit
V _{IT, TH+}	ITRIP positive going threshold		0.39	0.47	0.55	
V _{IT, HYS}	ITRIP input hysteresis		---	0.1	---	V
V _{RCIN, TH+}	RCIN positive going threshold		---	8	---	
V _{RCIN, HYS}	RCIN input hysteresis		---	1	---	
V _{OH}	High level output voltage, V _{BIAS} - V _O	I _O = 20 mA	---	0.7	1.0	
V _{OL}	Low level output voltage, V _O		---	0.2	0.4	
V _{CCUV+} V _{BSUV+}	V _{CC} and V _{BS} supply undervoltage positive going threshold		8.0	8.9	9.8	V
V _{CCUV-} V _{BSUV-}	V _{CC} and V _{BS} supply undervoltage negative going threshold		7.4	8.2	9.0	
V _{CCUVH} V _{BSUVH}	V _{CC} and V _{BS} supply undervoltage lockout hysteresis		0.3	0.7	---	
V _{IN_CLAMP}	Input clamp voltage (HIN, LIN, ITRIP and EN)	I _{IN} = 100 μA	---	6.6	---	
I _{LK}	Offset supply leakage current	V _{B1,2,3} = V _{S1,2,3} = 600 V	---	---	50	μA
I _{QBS}	Quiescent V _{BS} supply current	V _{IN} = 0 V	---	65	75	
I _{QCC}	Quiescent V _{CC} supply current		---	0.6	1	mA
I _{IN+}	Logic “1” input bias current	HIN1,2,3= 5 V LIN1,2,3= 5 V	---	80	100	μA
I _{IN-}	Logic “0” input bias current	HIN1,2,3= 0 V, LIN1,2,3= 0 V	---	0	1	
I _{ITRIP+}	“High” ITRIP input bias current	V _{ITRIP} = 5 V	---	36	50	
I _{ITRIP-}	“Low” ITRIP input bias current	V _{ITRIP} = 0 V	---	0	1	
I _{EN+}	“High” ENABLE input bias current	V _{ENABLE} = 5 V	---	40	55	
I _{EN-}	“Low” ENABLE input bias current	V _{ENABLE} = 0 V	---	0	1	
I _{RCIN}	RCIN input bias current	V _{RCIN} = 0 V or 15 V	---	0	1	
I _{O+}	Output high short circuit pulsed current	V _O = 0 V, V _{IN} = V _{IH} PW ≤ 10 μs	120	200	---	

Symbol	Parameter	Condition	Min.	Typ.	Max.	Unit
I_{O-}	Output low short circuit pulsed current	$V_O = 15\text{ V}, V_{IN} = V_{IL}$ $PW \leq 10\ \mu\text{s}$	250	350	---	
R_{on_RCIN}	RCIN low on resistance		---	25	50	Ω
R_{on_FAULT}	FAULT low on resistance		---	120	200	

FUNCTIONAL TABLE

VCC	VBS	ITRIP	ENABLE	FAULT	LO1,2,3	HO1,2,3
$< U_{VCC}$	X	X	X	0 (note 2)	0	0
15 V	$< U_{VBS}$	0 V	5 V	High imp	LIN1,2,3	0
15 V	15 V	0 V	5 V	High imp	LIN1,2,3(note 1)	HIN1,2,3(note 1)
15 V	15 V	$> V_{ITRIP}$	5 V	0 (note 3)	0	0
15 V	15 V	0 V	0 V	High imp	0	0

Note:

1. A shoot-through prevention logic prevents LO1,2,3 and HO1,2,3 for each channel from turning on simultaneously.
2. U_{VCC} is not latched, when $V_{CC} > U_{VCC}$, FAULT returns to high impedance.
3. When $ITRIP < V_{ITRIP}$, FAULT returns to high-impedance after RCIN pin becomes greater than 8 V (@ $V_{CC} = 15\text{ V}$).

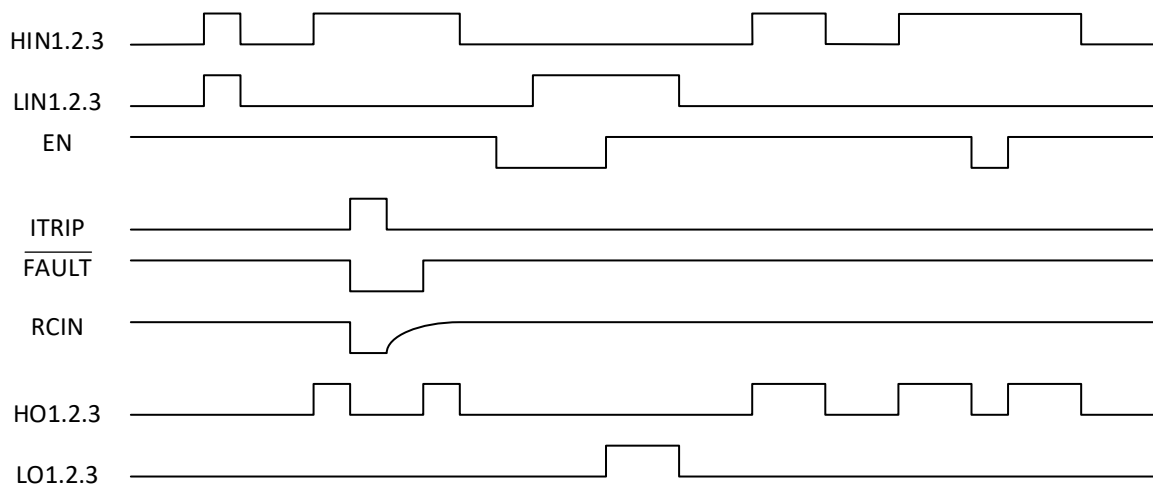

Figure 1. Input/output Timing Diagram

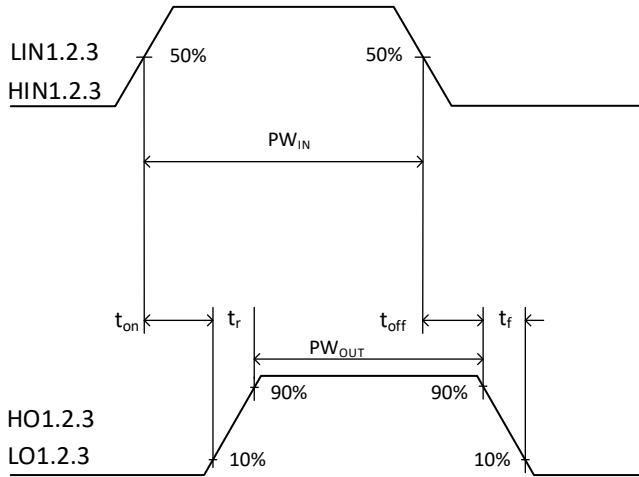

Figure 2. Switching Time Waveforms

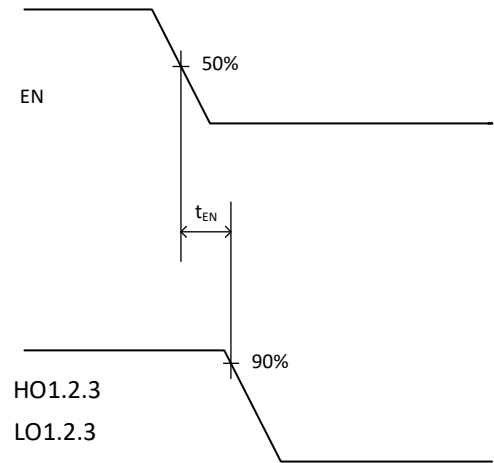

Figure 3. Output Enable Timing Waveform

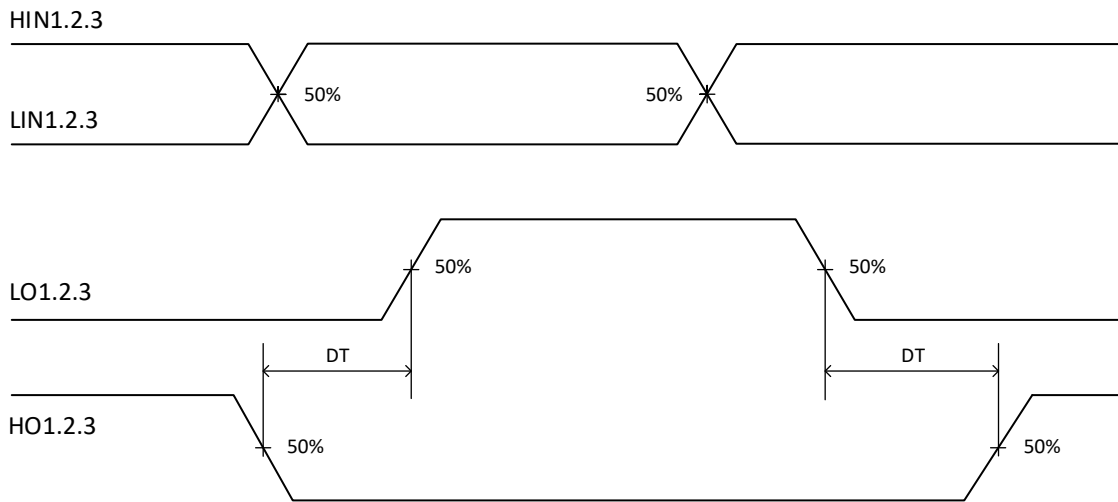

Figure 4. Internal Deadtime Timing Waveforms

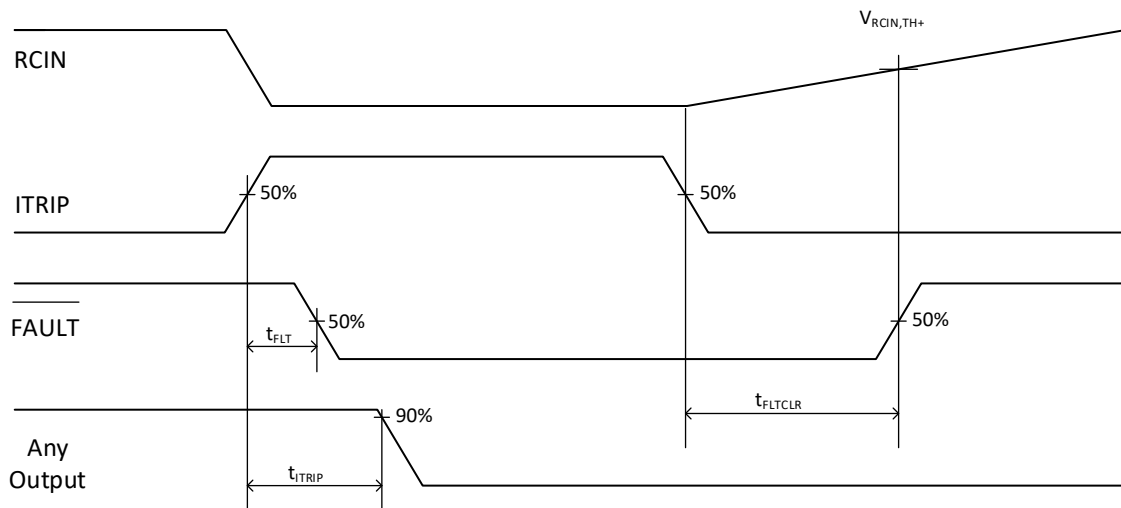

Figure 5. ITRIP/RCIN Timing Waveforms

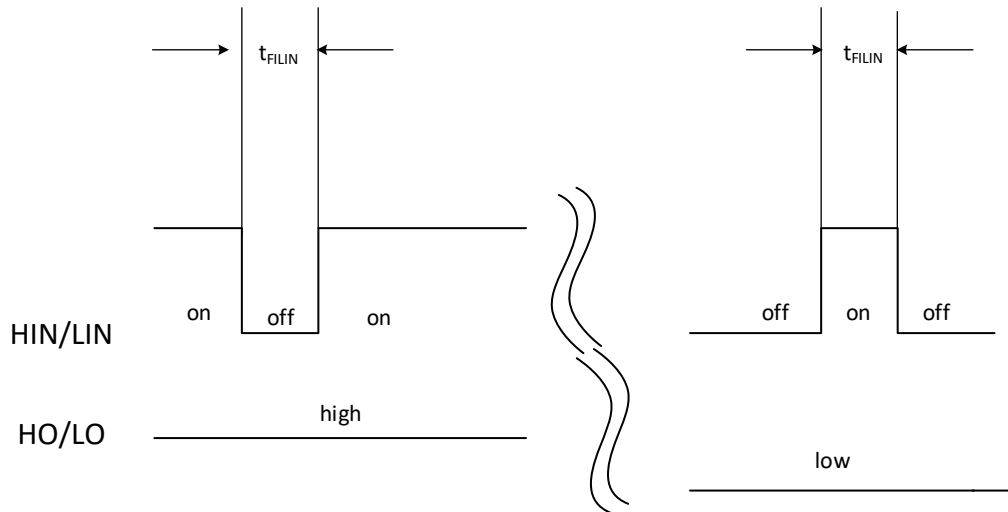

Figure 6. Input Filter Function

TYPICAL PERFORMANCE CHARACTERISTICS

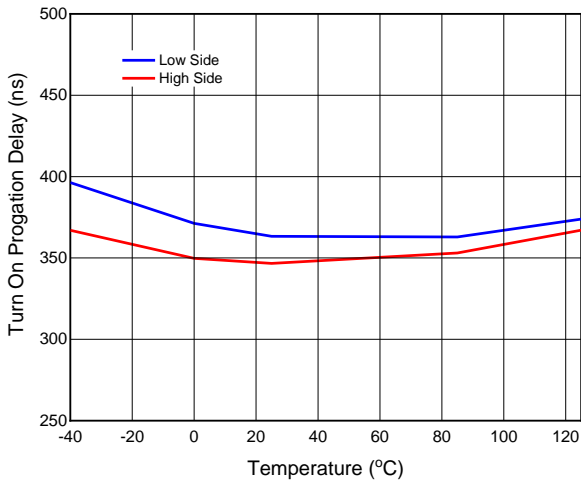

Figure 7. Turn On Time vs. Temperature

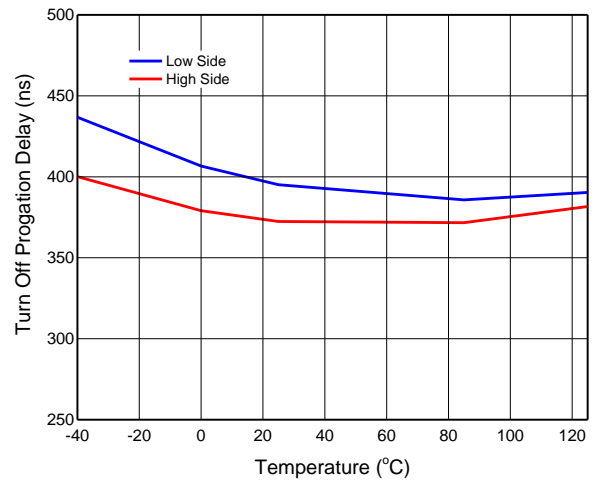

Figure 8. Turn Off Time vs. Temperature

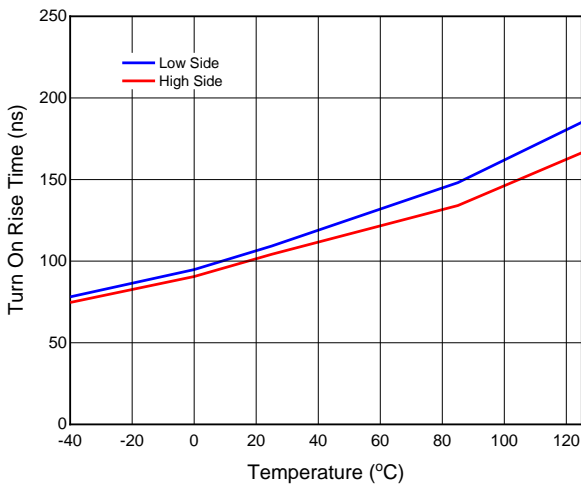

Figure 9. Turn On Rise Time vs. Temperature

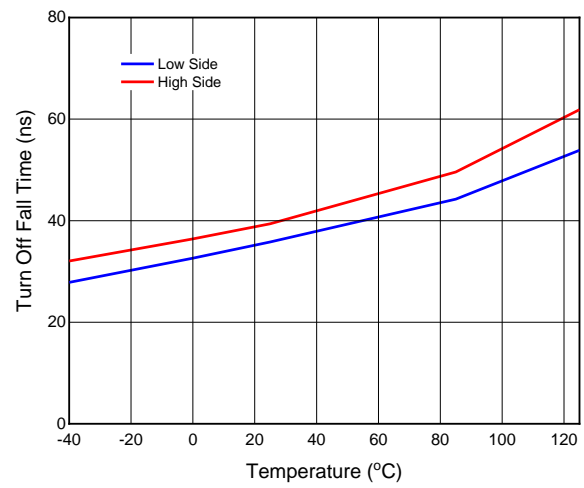

Figure 10. Turn Off Fall Time vs. Temperature

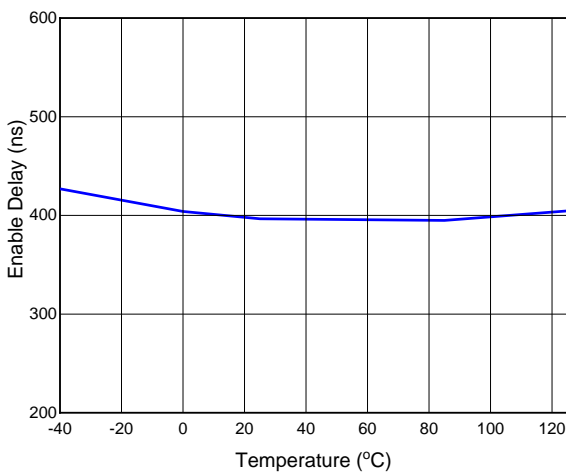

Figure 11. Enable Delay vs. Temperature

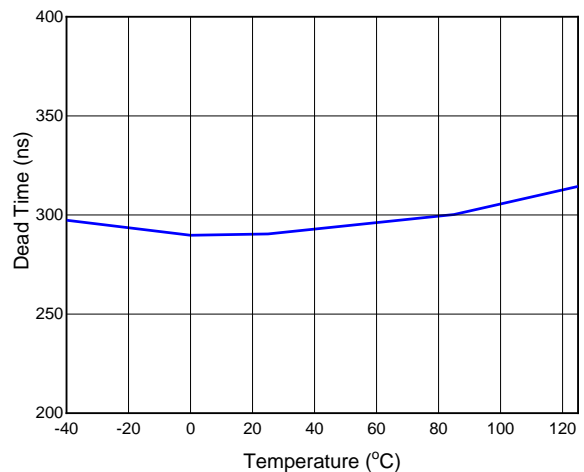

Figure 12. Dead Time vs. Temperature

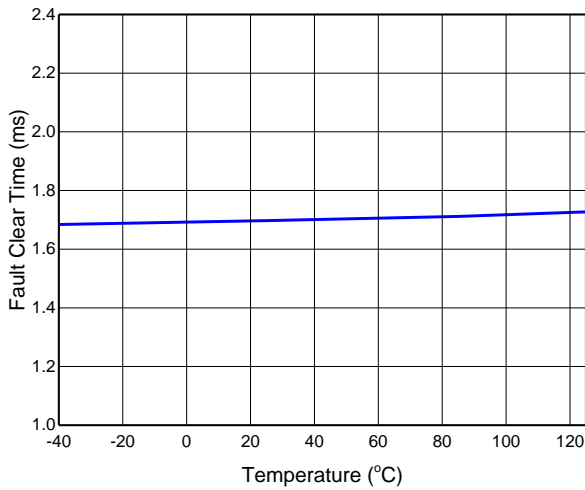

Figure 13. Fault Clear Time vs. Temperature

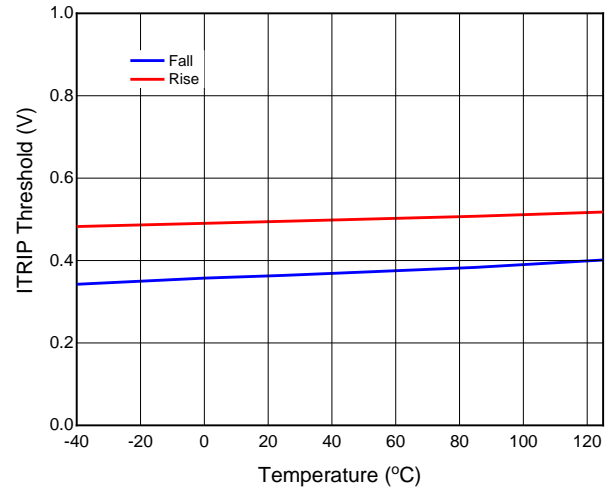

Figure 14. ITRIP Threshold vs. Temperature

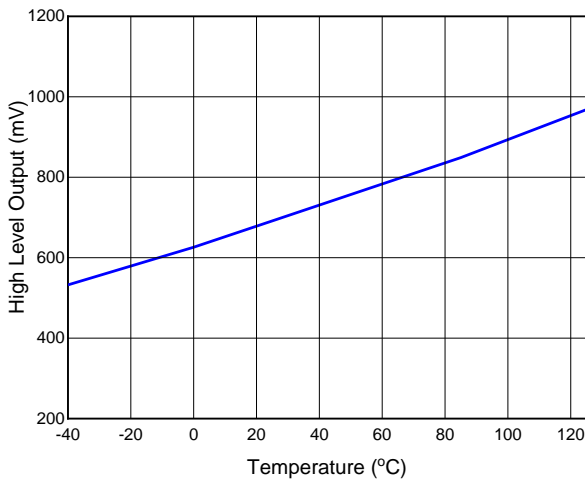

Figure 15. High Level Output Voltage vs. Temperature

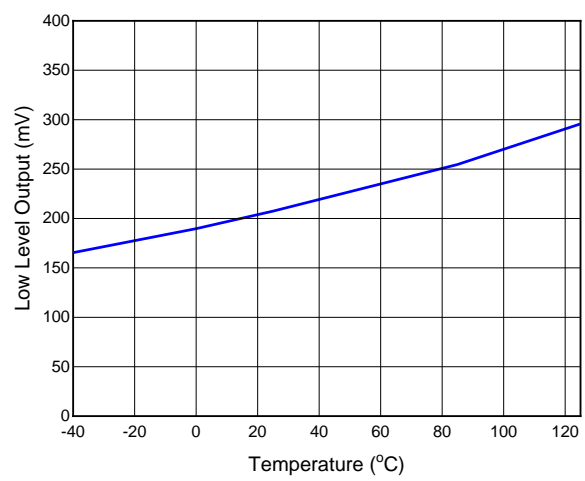

Figure 16. Low Level Output Voltage vs. Temperature

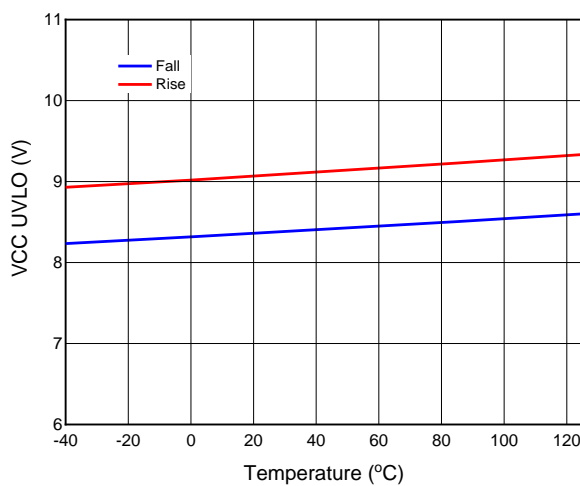

Figure 17. V_{CC} Under Voltage Threshold vs. Temperature

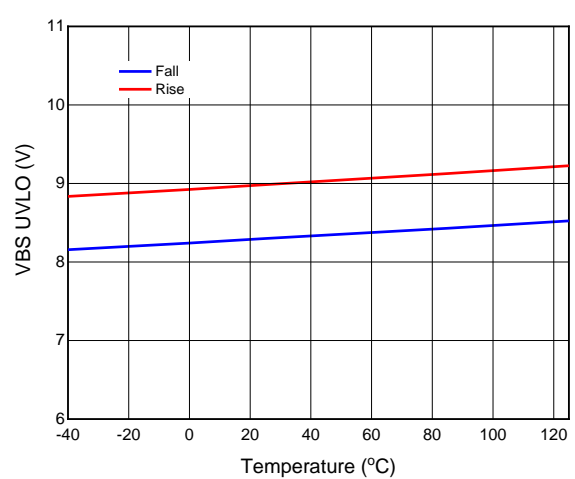

Figure 18. V_{BS} Under Voltage Threshold vs. Temperature

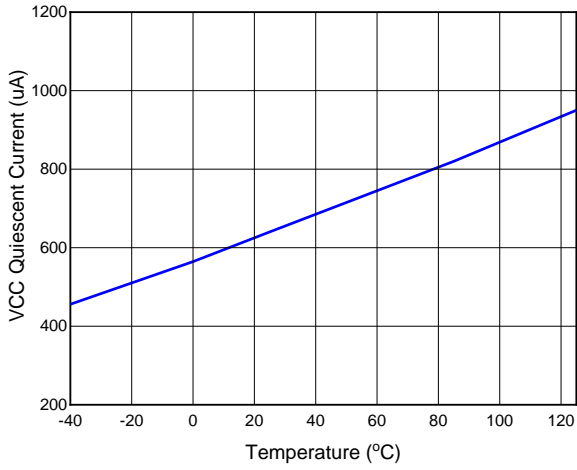

Figure 19. Vcc Quiescent Current vs. Temperature

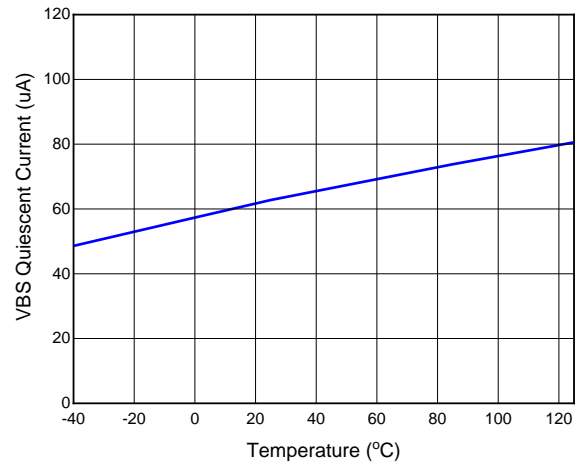

Figure 20. VBS Quiescent Current vs. Temperature

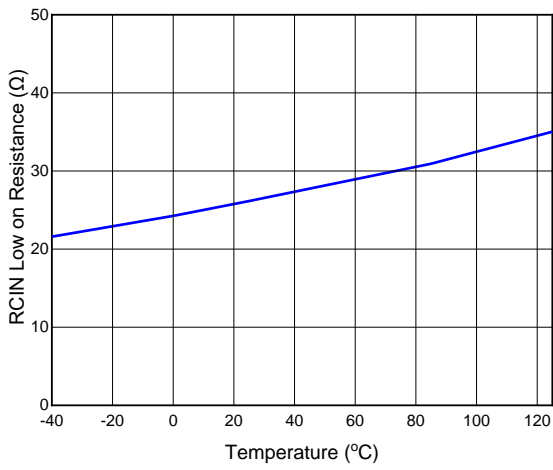

Figure 21. RCIN Low On Resistance vs. Temperature

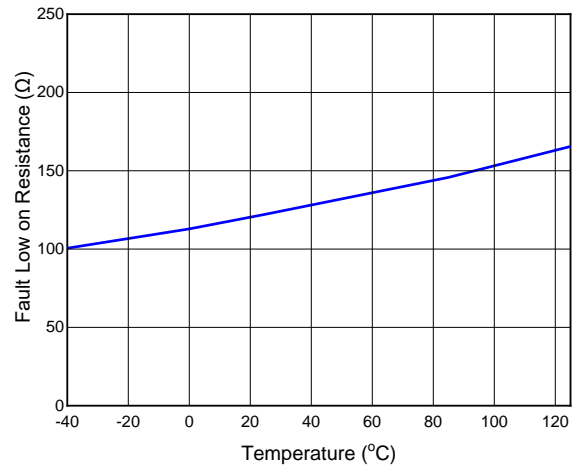

Figure 22. FAULT Low On Resistance vs. Temperature

PACKAGE CASE OUTLINES

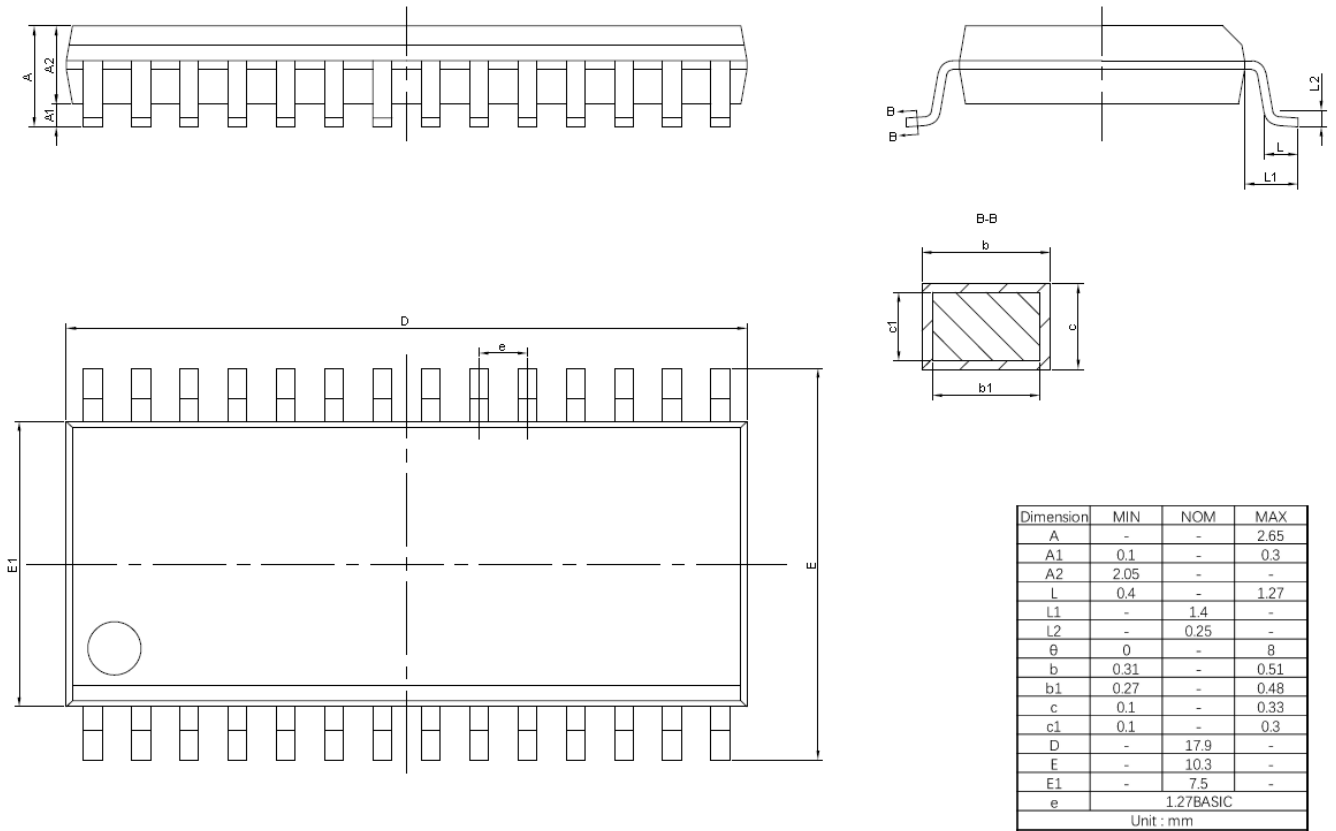

Figure 23. SOP28W Outline Dimensions

REVISION HISTORY

Note: page numbers for previous revisions may differ from page numbers in current version

Page or Item	Subjects (major changes since previous revision)
Rev 0.1 datasheet, 2020-1-14	
Whole document	Preliminary datasheet released
Rev 1.0 datasheet, 2022-7-20	
Whole document	Rev 1.0 datasheet released

X-ON Electronics

Largest Supplier of Electrical and Electronic Components

Click to view similar products for [Gate Drivers](#) category:

Click to view products by [Sillumin](#) manufacturer:

Other Similar products are found below :

[00053P0231](#) [56956](#) [57.404.7355.5](#) [LT4936](#) [57.904.0755.0](#) [5882900001](#) [00600P0005](#) [5951900000](#) [0131700000](#) [00-2240](#) [LTP70N06](#)
[LVP640](#) [5J0-1000LG-SIL](#) [LY2-US-AC240](#) [LY3-UA-DC24](#) [00576P0020](#) [LZNQ2-US-DC12](#) [LZP40N10](#) [0207100000](#) [0207400000](#)
[60100564](#) [60249-1-CUT-TAPE](#) [0134220000](#) [6035](#) [60713816](#) [M15730061](#) [61161-90](#) [61278-0020](#) [6131-204-23149P](#) [6131-205-17149P](#)
[6131-209-15149P](#) [6131-218-17149P](#) [6131-220-21149P](#) [6131-260-2358P](#) [6131-265-11149P](#) [CS1HCPU63](#) [6150300002](#) [6150-5001](#) [CSK-38-](#)
[60006](#) [CSK-38-60008](#) [621A](#) [622-4053LF](#) [6273](#) [M37730026](#) [M40N08MA-H](#) [M55155/29XH06](#) [64-807](#) [65003](#) [65-1930-6](#) [M82310002](#)