

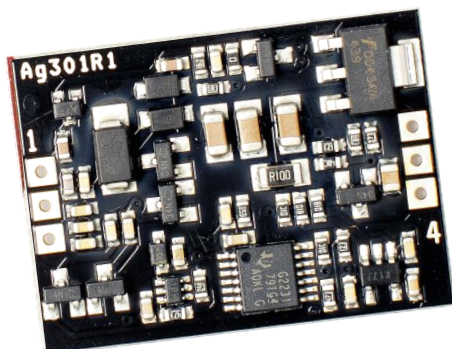

Ag301

Wireless Power Module



➤ Features

- Qi Compatible
- Output Power 5W
- Size 31.19mm x 22.88mm x 4.1mm
- Output Overload & Short-circuit Protection
- Simple Integration

Description

The Ag301 is a wireless charging receiver module; designed to work with the Ag311 or any other Qi compliant wireless power transmitter, typically used in wireless charging applications.

With the increased use of mobile & portable devices, the Ag301 & Ag311 wireless power modules offer a wide range of benefits: -

There are no cables to get tangled and you don't have the problem of having different plugs or sockets for various devices. There is no risk of electrical shock, as there are no exposed metal parts. Can be used in explosive environments as there are no contacts to cause sparks. This means that there is no contact degradation due to friction, corrosion or abrasion. The units can be completely sealed for use in harsh environments, as its operation is not affected by dirt, dust, water or chemicals and can even be used underwater. Can be used in medical environment where disinfecting and sterilization is required.

Table of Contents

1	Product Overview	3
1.1	Ag301 Product Selector	3
1.2	Purchasing Options:	3
1.3	Package Format	4
1.4	Pin Description	4
2	Functional Description	5
2.1	Wireless Power Overview	5
2.2	Coils and Alignment	6
2.1	Control Inputs	8
3	Typical Connections	9
4	Typical Applications	9
5	Operating Temperature	10
6	Output Protection	10
6.1	Over Current Protection	10
6.2	Short Circuit Protection	10
7	Electrical Characteristics	11
7.1	Absolute Maximum Ratings*	11
7.2	Recommended Operating Conditions	11
7.3	DC Electrical Characteristics*	11
8	Package	12

Table of Figures

Figure 1:	Block Diagram	3
Figure 2:	Ag312 Package Format	4
Figure 3:	Charger Overview	5
Figure 4:	Horizontal View	6
Figure 5:	Vertical View	6
Figure 6:	X Offset	7
Figure 7:	Y Offset	7
Figure 8:	Control Inputs	8
Figure 9:	Typical Application Drawing	9
Figure 10:	Ag301 Operating Temperature Profile	10
Figure 11:	Package Dimensions	12

1 Product Overview

1.1 Ag301 Product Selector

Part Number ¹	Output Voltage	Maximum Output Current	Type	Package	Date code ² Marking
Ag301	5V	1000mA	Receiver	DIL	WWYY

Note 1: Complies with the European Directive 2011/65/EU for the Restriction of use of certain Hazardous Substances (RoHS) including Directive 2015/863 published in 2015, amending Annex II of Directive 2011/65/EU. Moisture Sensitive Level 1 and HBM 1.

Note 2: Date code format: "WW" = Week Number, "YY" = Year.

Table 1: Ordering Information

1.2 Purchasing Options

Large volume customers of typically 100K+ can purchase the STX15 controller IC on its own and Silvertel will supply the applications circuit so the customer can assemble it themselves.

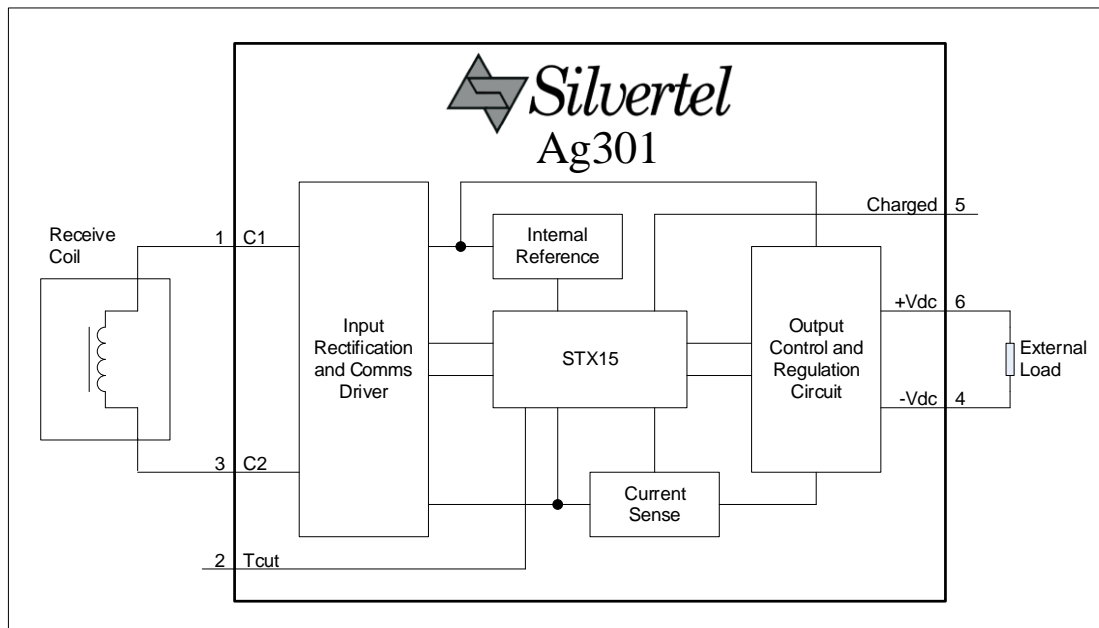

Figure 1: Block Diagram

1.3 Package Format

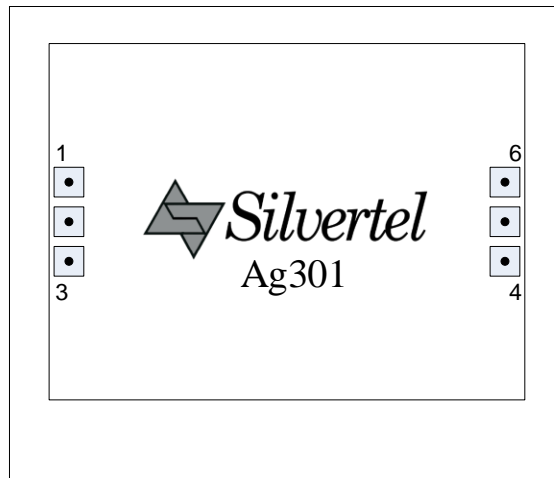

Figure 2: Ag312 Package Format

1.4 Pin Description

Pin	Name	Description
1	CL1	Coil (Input). This pin connects to one side of the receive coil.
2	TCUT	Thermal Cut Off (Input). This pin has a pull up in the STX15 controller to an internal 3.3V reference rail. Pulling this input low will force an error message to be sent to the transmitter.
3	CL2	Coil (Input). This pin connects to the other side of the receive coil.
4	VDC-	DC Return. This pin is the return path for the +VDC output.
5	Charged	Charged (Input). This pin has a pull up in the STX15 controller to an internal 3.3V reference rail. Pulling this input low will send a charged message to the transmitter.
6	VDC+	DC Output. This pin provides the regulated 5V output.

Table 2: Pin Description

2 Functional Description

2.1 Wireless Power Overview

When the Ag311 wireless transmitter is connected to a 19V supply, it will start up and will commence looking for an Ag301 wireless receiver in range.

It does this by applying a short power signal to the transmit coil to detect an object. If an object is detected then this signal is extended, looking for a Ping data message back from the receiver.

If a valid Ping message is not received, the transmitter will remove the power signal and wait ~500ms before repeating the above process.

If a valid “Ping” message is received, the power signal is maintained and the transmitter looks for the “Identification & Configuration” message and the “Power Transfer” message.

If either the “Identification & Configuration” or the “Power Transfer” messages are invalid, the transmitter will remove the power signal and wait ~500ms before repeating the above steps.

If the transmitter receives valid data, it will maintain and adjust the power signal in accordance with the data sent back from the receiver.

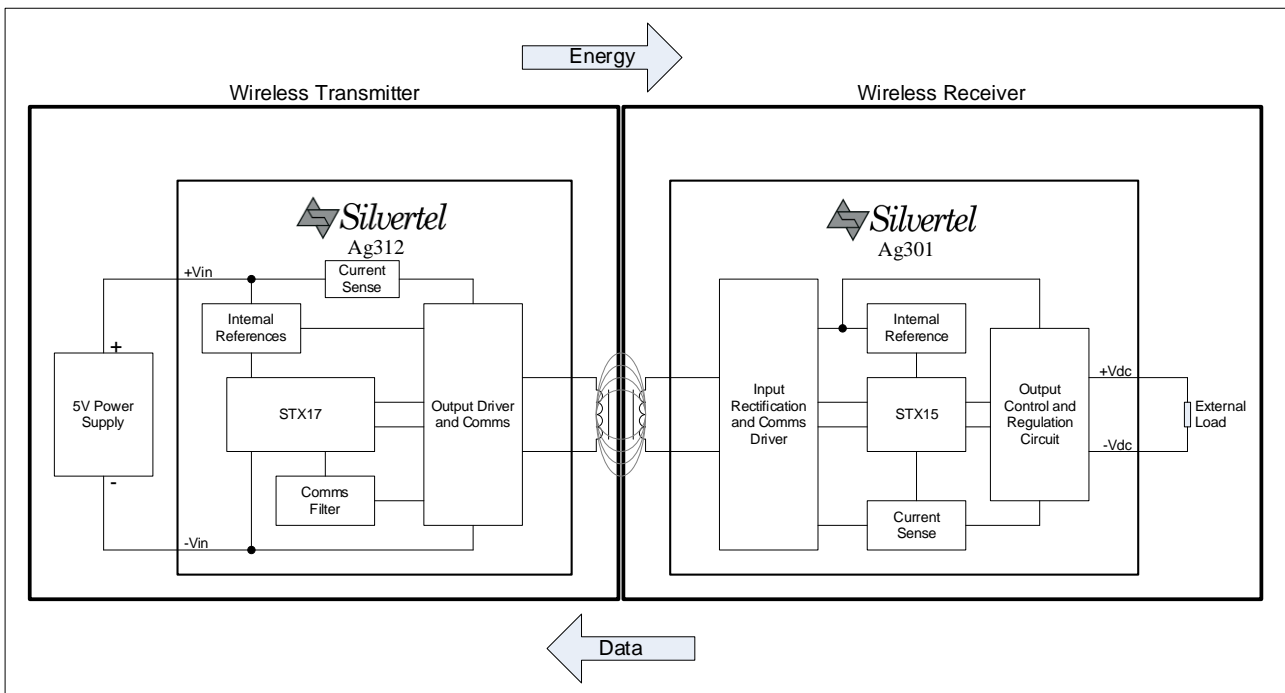

Figure 3: Charger Overview

2.2 Coils and Alignment

The wireless power connection is established through transmit and receive coils. For the Ag301 we recommend either an Elytone YT-28136, a Vishay IWAS-4832FF-50 or an equivalent.

The nominal alignment position of the coils is shown below in Figures 4 and 5 .

In Figure 4 you can see that the coils are separated by the transmitter and receiver enclosures. The Qi specification allows the transmitter enclosure thickness to be between 1.75mm to 2.5mm, and the receiver enclosure thickness to be between 0mm to 2.5mm. The Ag311 has been designed to meet this specification and the Ag301 is capable of operating well beyond the 2.5mm specification.

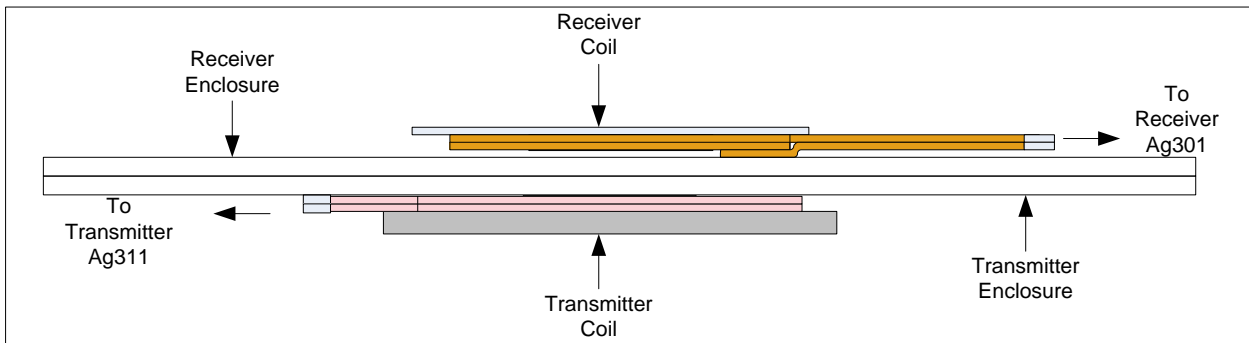

Figure 4: Horizontal View

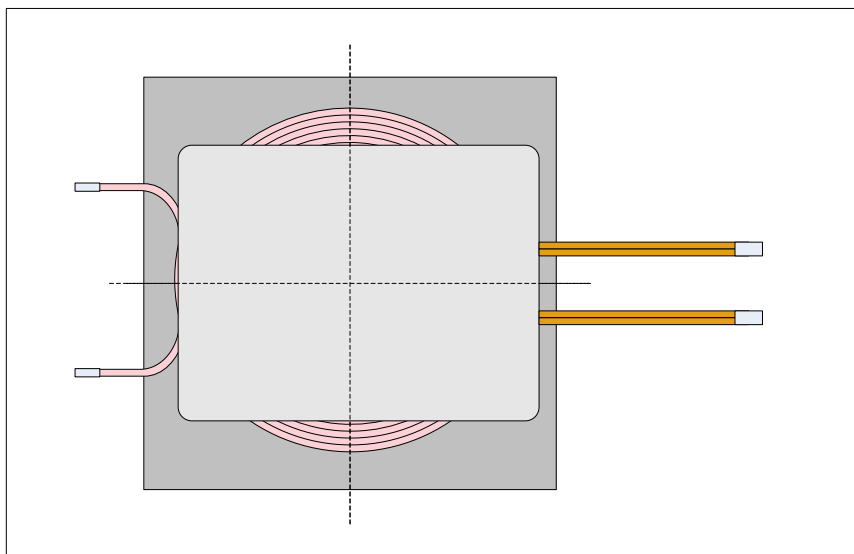

Figure 5: Vertical View

Figure 5 shows the Ag301 and Ag311 coils perfectly centred, which is the optimum position for power and data transfer. But the Ag301 and Ag311 will operate if the coils are not perfectly centred. Figures 6 and 7 show the amount the coils can be offset, still allowing the Ag301 and Ag311 to start up even at full load.

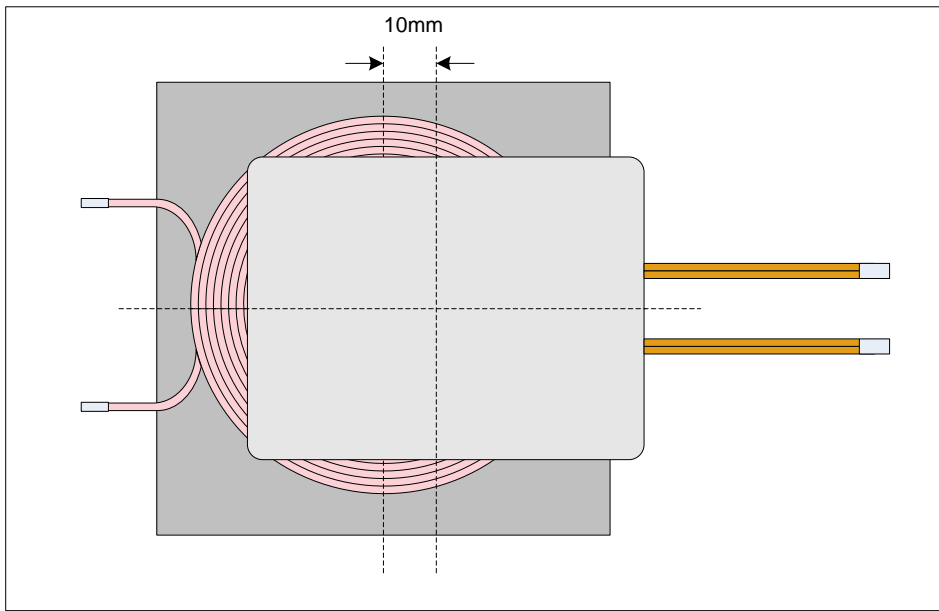

Figure 6: X Offset

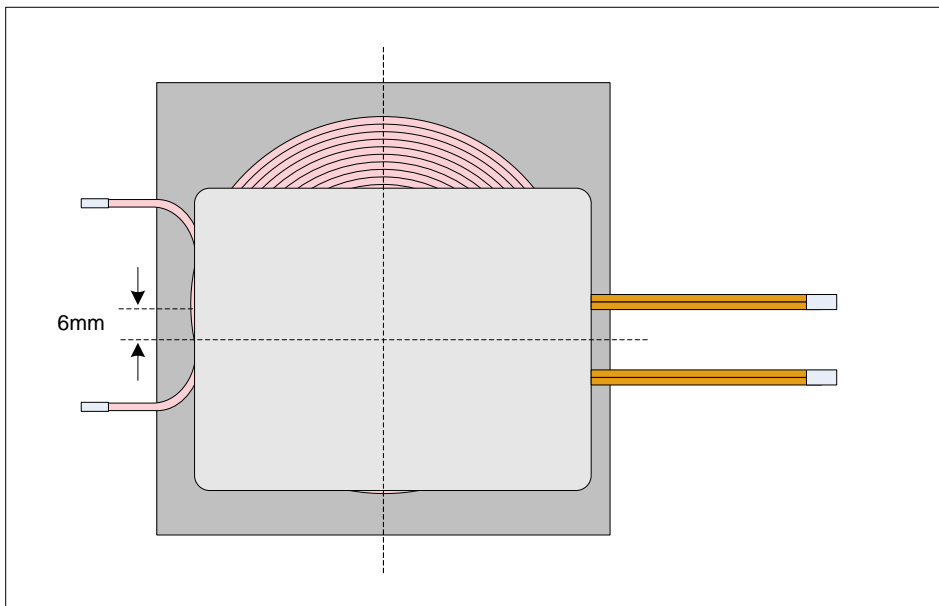

Figure 7: Y Offset

Once the Ag301 is fully up and running, the X Offset can be increased to ~20mm or the Y Offset increased to ~17mm.

2.1 Control Inputs

The Ag301 has two optional control inputs: – Thermal Cut Off and Charged.

Both of these inputs have pull-ups to an internal 3.3V reference. They can be driven directly from a controller (of logic gate) that has a 3.3V rail, or via an external transistor if the external rail is not 3.3V (see Figure 8).

It is important that if Figure 8 “Option A” is used, that the Controller outputs are tri-state or high at start-up. If this is an issue then “Option B” may be a better solution. The two transistors do not need to be anything special and could both be in a dual package, if required. The resistors can be high values (100KΩ) and could be in a quad package if required.

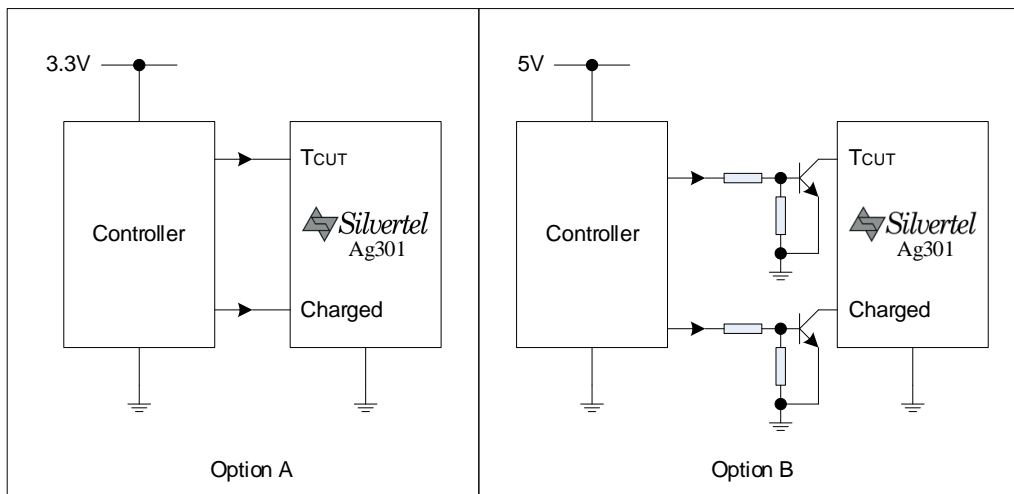

Figure 8: Control Inputs

2.1.1 Thermal Cut Off

The Thermal Cut Off input (T_{CUT}) can be used with an external circuit for battery protection.

When this input is pulled low, the Ag301 will send an error message back to the Transmitter. If the Ag311 is being used, it will power cycle twice to see if the error can be cleared, but if the error is still present after this, it will remain off and show an error code.

2.1.2 Charged

The Charged input can be used to send a message back to the transmitter when the battery is fully charged.

When this input is pulled low, the Ag301 will send a message back to the Transmitter saying that the charge is complete.

3 Typical Connections

The Ag301 is very easy to implement, Figure 9 shows typical application drawing, giving a basic overview.

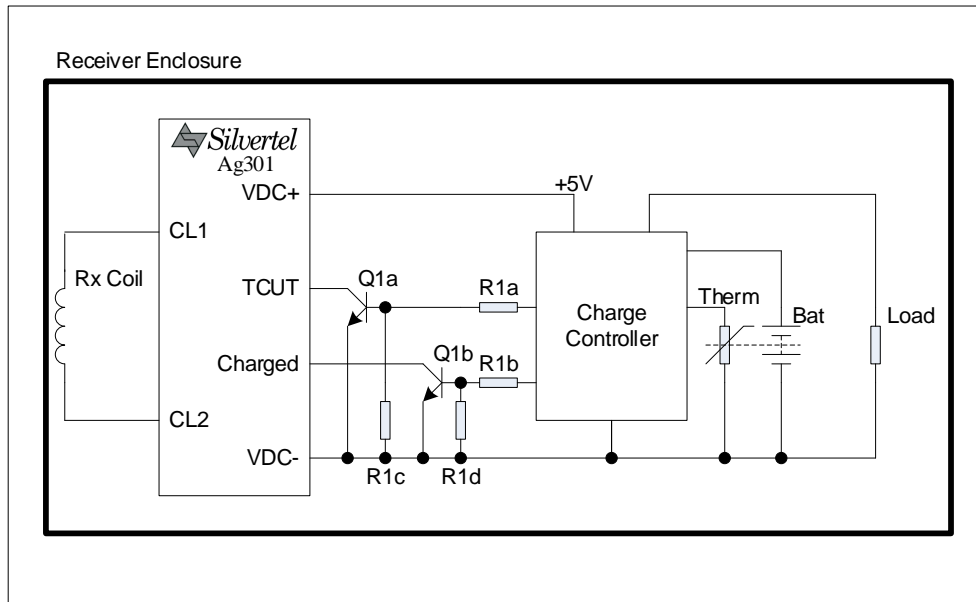

Figure 9: Typical Application Drawing

4 Typical Applications

The Ag301 can be used in a wide range of wireless power and charging applications and with the increased use of mobile & portable devices this list is expanding every day.

At present one of the biggest market sectors for wireless charging are in mobile phones.

But there are many more applications that can benefit from the advantages of wireless power transfer.

Because there are no contacts to cause sparks, wireless charging can be used in environments where combustible materials or gases are present.

Also as the transmitter and receiver can be built into completely sealed enclosures; they can be used in harsh environments, where dust, dirt, water or chemicals are present.

On the other end of the spectrum, wireless power also lends itself for use in clean environments, where disinfecting and sterilization is required.

5 Operating Temperature

The Ag301 has to rectify and regulate the voltage received from the (Ag311) transmitter. The losses incurred by these processes will result in the module generating heat and as a result this will need to be taken into consideration.

The amount of heat generated by the module is primarily related to the current being drawn by the load. So care needs to be taken to control the ambient temperature around the module.

The Ag301 has a maximum ambient operating temperature of 70°C, as shown in Figure 10. These results were performed in an environmental chamber (Associated Environmental Systems – SD-302), without any heat-sinking.

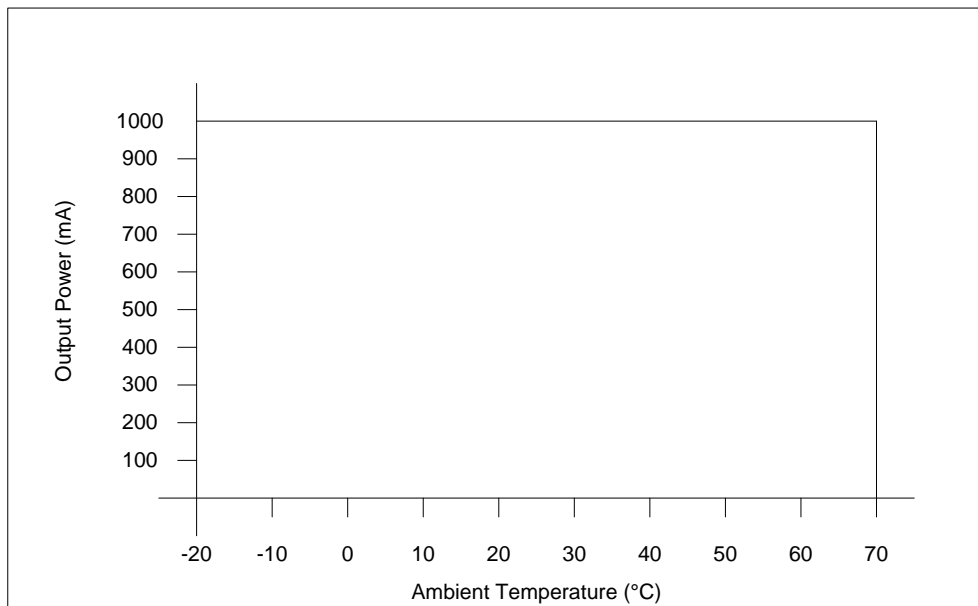

Figure 10: Ag301 Operating Temperature Profile

6 Output Protection

6.1 Over Current Protection

The Ag301 output has an over current protection threshold set to ~1.2A. If the load attempt to draw > ~1.2A it will disconnect the output and report an over current error back to the transmitter.

6.2 Short Circuit Protection

The Ag301 output is capable of handling a direct short circuit without any damage to the module.

Note: recovery from the above output protection conditions will depend on the transmitter being used.

7 Electrical Characteristics

7.1 Absolute Maximum Ratings*

	Parameter	Symbol	Min	Max	Units
1	Storage Temperature	T_S	-40	+100	°C
2	Control Inputs Maximum DC Rating	V_{IN}	-0.3	3.5	V

Note: Exceeding the above ratings may cause permanent damage to the product. Functional operation under these conditions is not implied. Maximum ratings assume free airflow.

7.2 Recommended Operating Conditions

	Parameter	Symbol	Min	Typ	Max	Units
1	Operating Temperature	T_{OP}	-20	25	70 ¹	Ta / °C
2	Maximum Input Voltage (From Coil)	V_{INC}			10	Vp-p

Note 1: See Section 0

7.3 DC Electrical Characteristics*

	DC Characteristic	Sym	Min	Typ ¹	Max	Units	Test Comments
1	Output Voltage	V_{OUT}	4.75	5	5.25	V	@ 50% Load
2	Output Current	I_{OUT}			1	A	
3	Over-Load Current	I_{OL}		1.2		A	
4	Load Regulation	V_{REG}		2		%	
5	Peak Efficiency	EFF		71.29		%	With Ag311
6	Short Circuit Duration	T_{SC}			∞	sec	
7	Minimum Load	I_{MIN}	0			mA	
8	Output Ripple and Noise (Minimum Load) ²	V_{RN1}		100		mVp-p	
9	Output Ripple and Noise (Maximum Load) ¹	V_{RN2}		157		mVp-p	
10	Maximum Start Up Distance Between Coils	D_{ST}		7		mm	@ Full Load
11	Maximum Operating Distance Between Coils	D_{OP}		12		mm	@ Full Load
12	Control Inputs Logic Low Voltage	V_{IL}			0.75	V	
13	Control Inputs Logic High Voltage	V_{IH}	2.25			V	

Note 1: Typical figures are at 25°C and are for design aid only. Not Guaranteed

Note 2: This can be reduced with additional output capacitance or filter.

8 Package

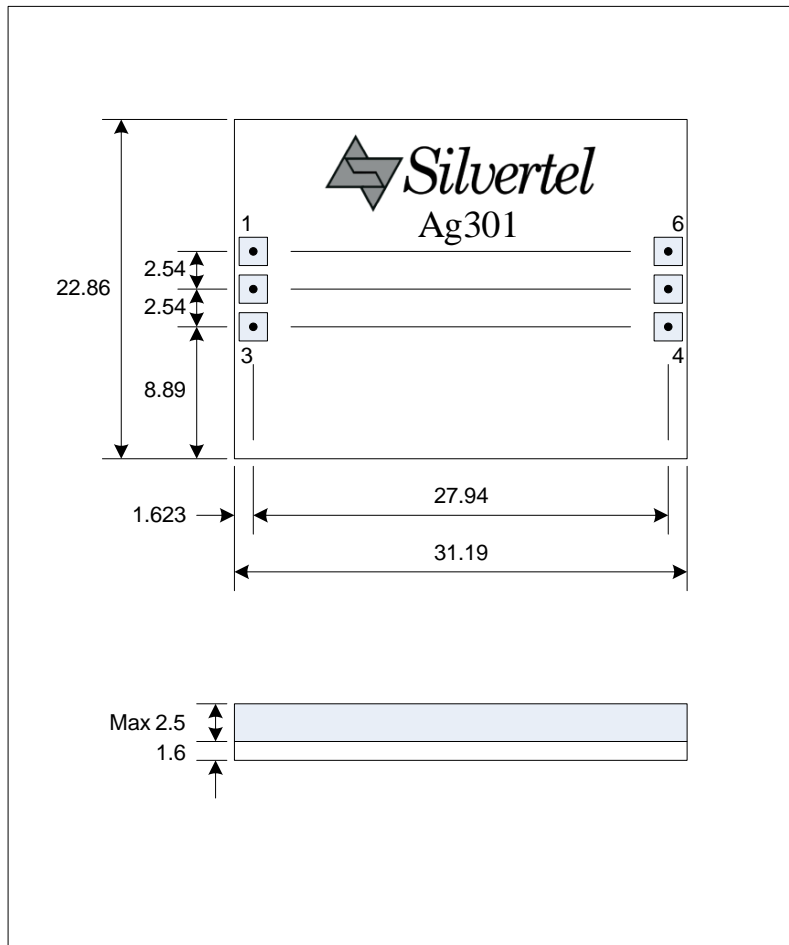

Figure 11: Package Dimensions

Information published in this datasheet is believed to be correct and accurate. Silver Telecom assumes no liability for errors which may occur or for liability otherwise arising out of use of this information or infringement of patents which may occur as a result of such use. No license is granted by this document under patents owned by Silver Telecom or licensed from third parties by Silver Telecom. The products, their specification and information appearing in this document are subject to change by Silver Telecom without notice.

X-ON Electronics

Largest Supplier of Electrical and Electronic Components

Click to view similar products for [Power Management Modules](#) category:

Click to view products by [Silvertel](#) manufacturer:

Other Similar products are found below :

[FPF1C2P5BF07A](#) [FH2000NPBAP](#) [B0505S-2W](#) [B0305S-1W](#) [B0505S-1WR3](#) [AP24N20-HV](#) [TAD10-1505-NI](#) [TDK30-24S15W](#) [LD03-23B05R2](#) [LD05-23B12R2](#) [URB2415YMD-10WR3](#) [A2409S-1W](#) [IB2412LS-1WR3](#) [IF2405S-1WR3](#) [IB2405S-W75R3](#) [A1205XT-1WR3](#) [A1215XT-1WR3](#) [F1205XT-2WR3](#) [E1215XT-1WR3](#) [E2415XT-1WR3](#) [F1205XT-1WR3](#) [IB1205XT-W75R3](#) [A2405S-1WR2](#) [A1215S-1WR2](#) [A2415S-1WR2](#) [B2405D-1WR3](#) [F1205N-1WR3](#) [F2405N-1WR3](#) [F1205S-2WR3](#) [F2405S-2WR3](#) [HCS2-24S12](#) [HCES1-05S12](#) [HCES1-24S05](#) [HCES1-05D05](#) [HCES1-12D05](#) [HCES2-05D15](#) [HCES2-24D12](#) [HCS1-24D12](#) [HCES2-24S15](#) [UD6-18S15A1](#) [HA25-220S24H2](#) [FD30-18S12B3](#) [IA1205KS-2W](#) [IA2405KS-2W](#) [B1505S-1WX](#) [NV25A12](#) [H14NG03-A05](#) [H14NG03-A12](#) [WG15A05](#) [NJ02-A05L](#)