

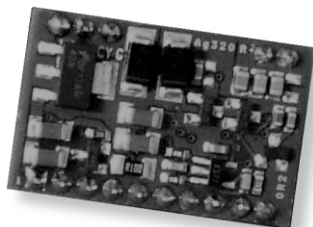

Ag320R

15 Watt Wireless Power Modules



1 Features

- 15 Watt proprietary wireless power receiver
- Output Power 15W @ 12V, 1.3A
- Low bit rate customer communication
- Size 28 mm x 18 mm x 6.7mm
- Output Overload & Short-circuit Protection
- Simple Integration

2 Description

The Ag320R is a 15 watt wireless power receiver module; designed to work with the Ag320T wireless power transmitter, typically used in wireless charging applications.

With the increased use of mobile & portable devices, the Ag320R & Ag320T wireless power modules offer a wide range of benefits: -

There are no cables to get tangled and you don't have the problem of having different plugs or sockets for various devices. There is no risk of electrical shock, as there are no exposed metal parts. Can be used in explosive environments as there are no contacts to cause sparks. This means that there is no contact degradation due to friction, corrosion or abrasion. The units can be completely sealed for use in harsh environments, as its operation is not affected by dirt, dust, water or chemicals and can even be used underwater. Can be used in medical environment where disinfecting and sterilization is required. Has 3 times the power of standard Qi wireless power making it suitable for a wide range of higher power applications.

2.1 Table of Contents

1	Features	1
2	Description.....	1
2.1	Table of Contents	2
2.2	Table of Figures.....	2
3	Ag320R Product Selector [†]	3
4	Pin Description	4
4.1	Ag320R	4
5	Functional Description	6
5.1	Wireless Power Overview.....	6
5.2	Coils and Alignment.....	7
5.3	Control Inputs	9
5.3.1	Thermal Cut Off.....	9
5.3.2	Charged.....	9
5.4	Customer communications input	10
6	Typical Connections	11
7	Typical Applications	12
8	Operating Temperature	12
9	Output Protection.....	14
9.1	Over Current Protection.....	14
9.2	Short Circuit Protection.....	14
10	Electrical Characteristics.....	14
10.1	Absolute Maximum Ratings*.....	14
10.2	Recommended Operating Conditions.....	14
10.3	DC Electrical Characteristics*	14
11	Package	16

2.2 Table of Figures

Figure 1:	Ag320R Block Diagram	3
Figure 2:	Ag320R Package Format	5
Figure 3:	Charger Overview	6
Figure 4:	Horizontal View.....	7
Figure 5:	Vertical View	7
Figure 6:	X Offset.....	8
Figure 7:	Y Offset.....	8
Figure 8:	Control Inputs	9
Figure 9:	SPI input timing diagram.....	10
Figure 10:	Ag320R user application code example	11
Figure 11:	Typical Application Drawing.....	11
Figure 12:	Ag320R Operating Temperature Profile with nominal distance	13
Figure 13:	Ag320R Operating Temperature Profile maximum distance.....	13

3 Ag320R Product Selector†

Part Number	Input Voltage	Output Voltage	Maximum Output Current	Type
Ag320R		12V	1300mA	Receiver

† The Ag320R fully meets the requirements of the RoHS directive 2002/95/EC on the restriction of hazardous substances in electronic equipment.

Table 1: Ordering Information

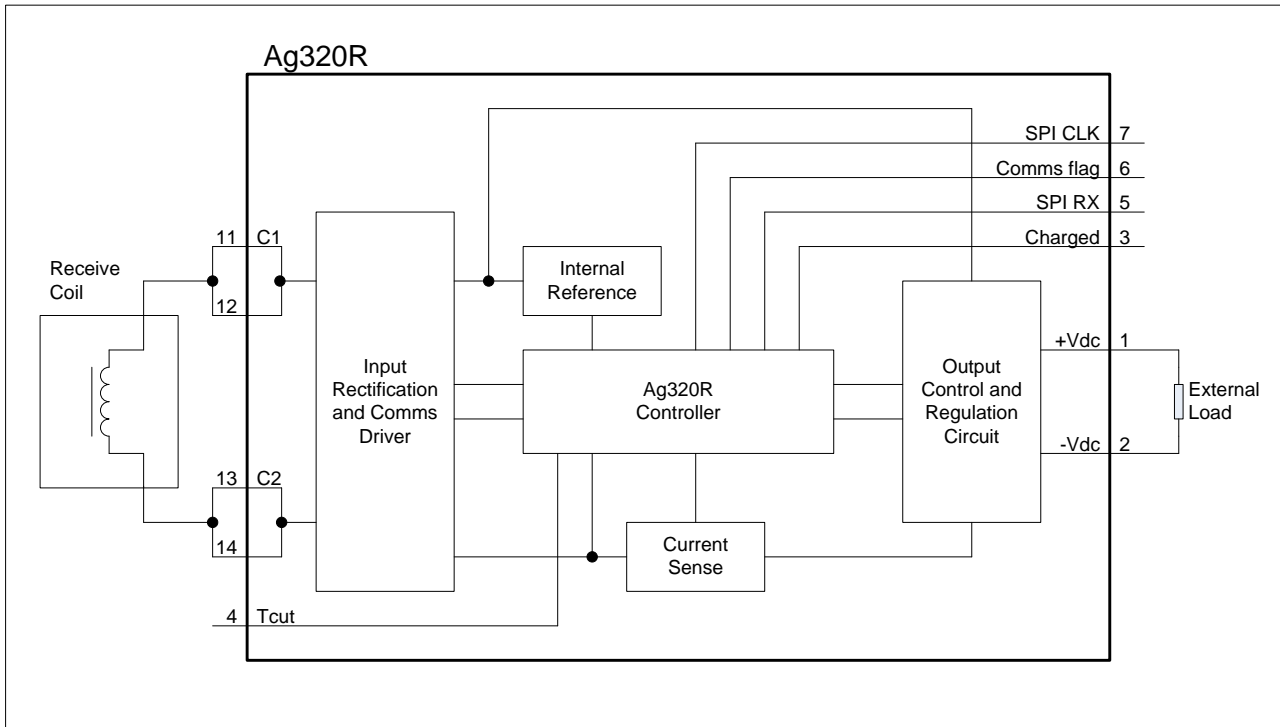

Figure 1: Ag320R Block Diagram

4 Pin Description

4.1 Ag320R

Pin	Name	Description
1	+Vdc	DC Output. This pin provides the regulated 12V output.
2	-Vdc	DC Return. This pin is the return path for the +VDC output.
3	Charged	Charged (Input). This pin has a pull up in the module's controller to an internal 3.3V reference rail. Pulling this input low will send a message to the transmitter to indicate battery is fully charged.
4	Tcut	Tcut (Input). Pulling this input low, will stop the Ag320T transmitting power. This pin has an internal pull up to a +3.3V rail.
5	SPI RX	SPI RX (Input). Limited transmission channel for customer data in SPI (Serial Peripheral Interface) format.
6	Comms flag	Comms flag (Outputs). This pin indicates the status of the customer communications.
7	SPI Clk	SPI Clk (Input). Clock input for communications channel.
8	NC	
9	NC	
10	NC	
11	C1	Coil (Input). This pin connects to one side of the receive coil.
12		
13	C2	Coil (Input). This pin connects to the other side of the receive coil.
14		
15	NC	

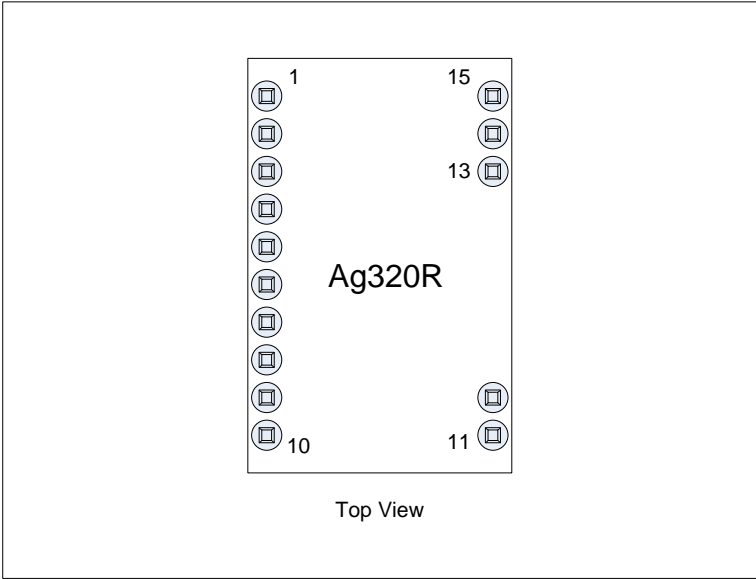

Figure 2: Ag320R Package Format

5 Functional Description

5.1 Wireless Power Overview

When the Ag320T wireless transmitter is connected to a 12V supply, it will start up and will commence looking for an Ag320R wireless receiver in range.

It does this by applying a short power signal to the transmit coil to detect an object. If an object is detected then this signal is extended, looking for a Ping data message back from the receiver.

If a valid Ping message is not received, the transmitter will remove the power signal and wait ~500ms before repeating the above process.

If a valid “Ping” message is received, the power signal is maintained and the transmitter looks for the “Identification & Configuration” message and the “Power Transfer” message.

If either the “Identification & Configuration” or the “Power Transfer” messages are invalid, the transmitter will remove the power signal and wait ~500ms before repeating the above steps.

If the transmitter receives valid data, it will maintain and adjust the power signal in accordance with the data sent back from the receiver.

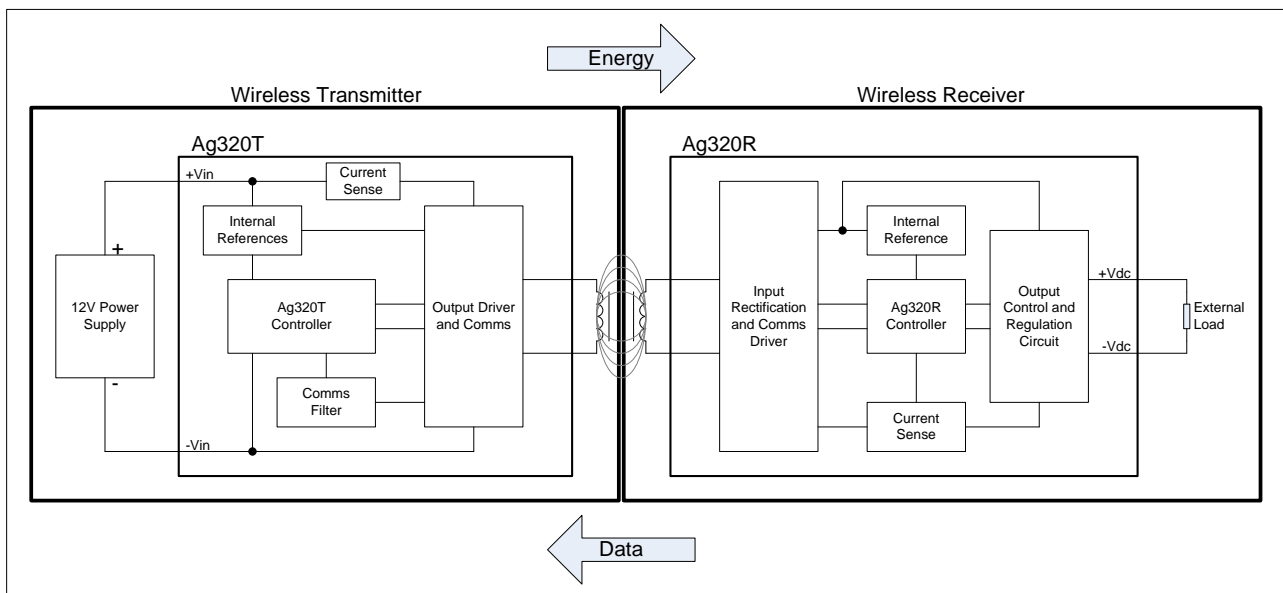

Figure 3: Charger Overview

5.2 Coils and Alignment

The wireless power connection is established through transmit and receive coils. For the Ag320R we recommend one of the following parts or an equivalent: -

Manufacturer	Part number
Abracon	Awcca-38r32h09-c01
Abracon	Awcca-48r32h11-c01
Würth Elektronik	760308103205
Würth Elektronik	760308201
Würth Elektronik	760308100141

The nominal alignment position of the coils is shown below in Figure 4 and 5.

In Figure 4 you can see that the coils are separated by the transmitter and receiver enclosures. The Qi specification allows the transmitter enclosure thickness to be between 1.5mm to 2.25mm, and the receiver enclosure thickness to be between 0mm to 2.5mm. The Ag320T has been designed to meet this specification and the Ag320R is capable of operating well beyond the 2.5mm specification.

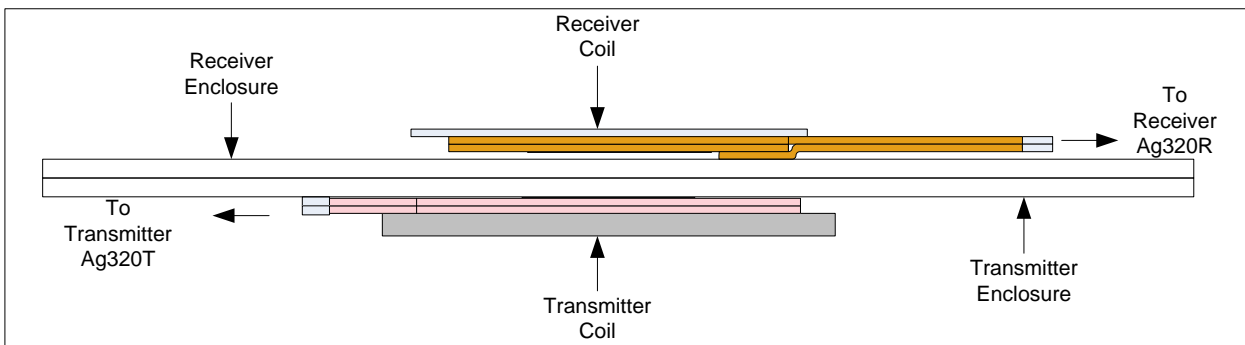

Figure 4: Horizontal View

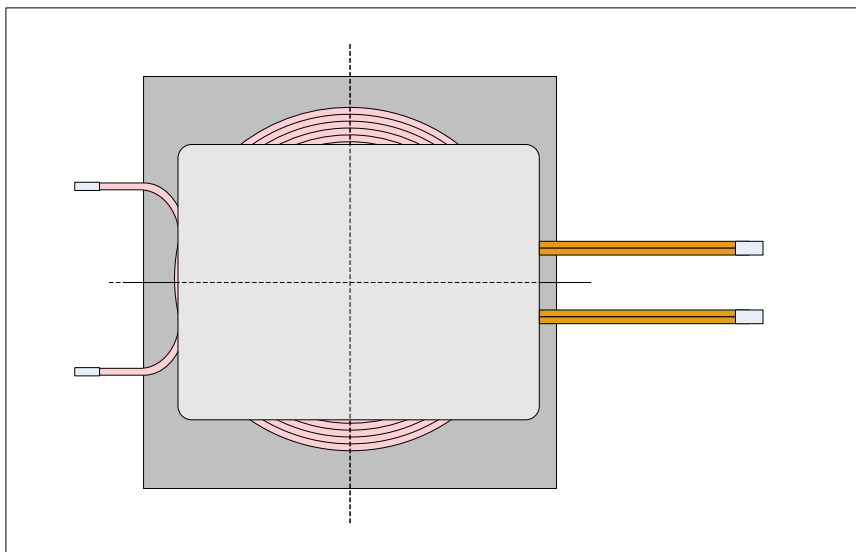

Figure 5: Vertical View

Figure 5 shows the Ag320R and Ag320T coils perfectly centred, which is the optimum position for power and data transfer. But the Ag320R and Ag320T will operate if the coils are not perfectly centred. Figures 6 and 7 show the amount the coils can be offset, still allowing the Ag320R and Ag320T to start up even at full load.

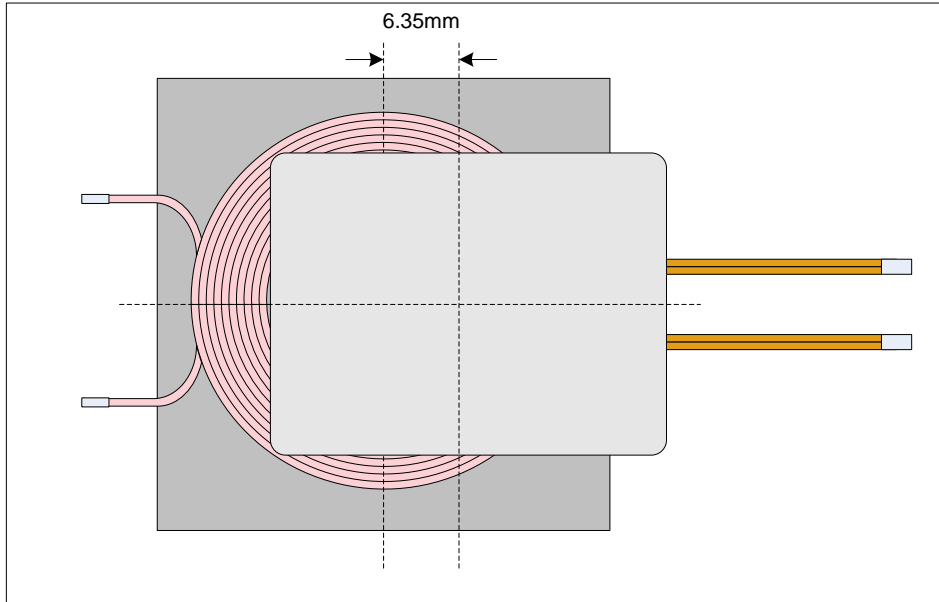

Figure 6: X Offset

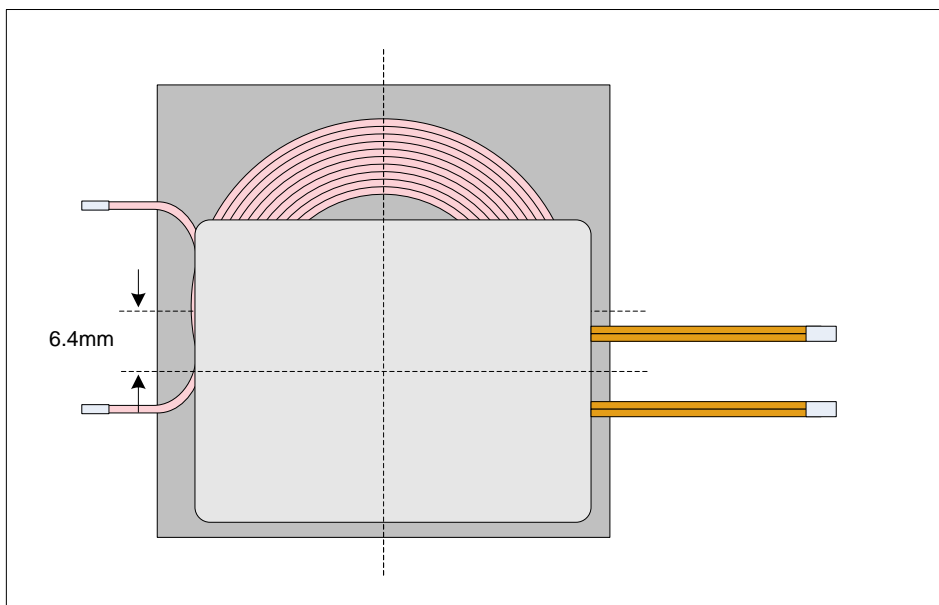

Figure 7: Y Offset

Once the Ag320R is fully up and running, the X Offset can be increased to ~6.35mm or the Y Offset increased to ~6.4mm.

5.3 Control Inputs

The Ag320R has two optional control inputs: – Thermal Cut Off and Charged.

Both of these inputs have pull-ups to an internal 3.3V reference. They can be driven directly from a controller (of logic gate) that has a 3.3V rail, or via an external transistor if the external rail is not 3.3V (see Figure 8).

It is important that if Figure 8 “Option A” is used, that the Controller outputs are tri-state or high at start-up. If this is an issue then “Option B” may be a better solution. The two transistors do not need to be anything special and could both be in a dual package, if required. The resistors can be high values (100K Ω) and could be in a quad package if required.

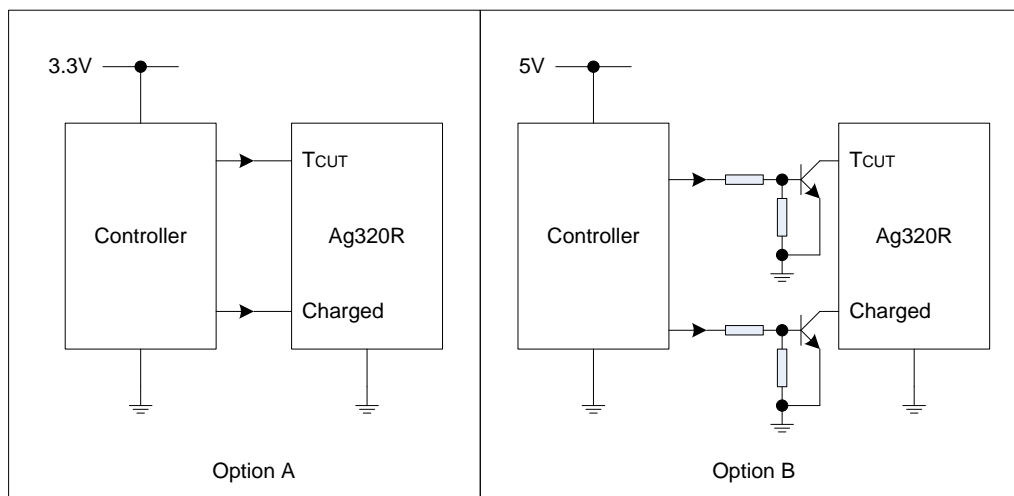

Figure 8: Control Inputs

5.3.1 Thermal Cut Off

The Thermal Cut Off input (T_{CUT}) can be used with an external circuit for battery protection.

When this input is pulled low, the Ag320R will send an error message back to the Ag320T. It will power cycle twice to see if the error can be cleared, but if the error is still present after this, it will remain off and show an error code.

5.3.2 Charged

The Charged input can be used to send a message back to the transmitter when the battery is fully charged.

When this input is pulled low, the Ag320R will send a message back to the Transmitter saying that the charge is complete.

5.4 Customer communications input

The Ag320R has an input for a low bit rate communications channel for the application use. The communications channel is 1 way from the Ag320R to Ag320T.

The communication is transmitted over the power interface, using the same method as the power control data. This means the data rate is limited and varies depending on load variation. It has an approximate maximum of 4 bytes per second when the load is stable.

The Ag320R interfaces with the customer's application via 2 wire SPI (SPI clock and SPI Rx) and a communication status flag (Comms flag) pin. Once the Ag320R is ready to accept data the status flag will go HIGH. 1 byte can be transferred via the SPI to the Ag320R. Once received the communication status flag will go low. The byte of data will then be transmitted back to the Ag320T in the next available time slot. Once sent the communication status flag will return to HIGH to indicate the Ag320R is ready for the next byte of data. If extra bytes of data are transmitted when the Ag320R is not ready they may corrupt the original message or be lost.

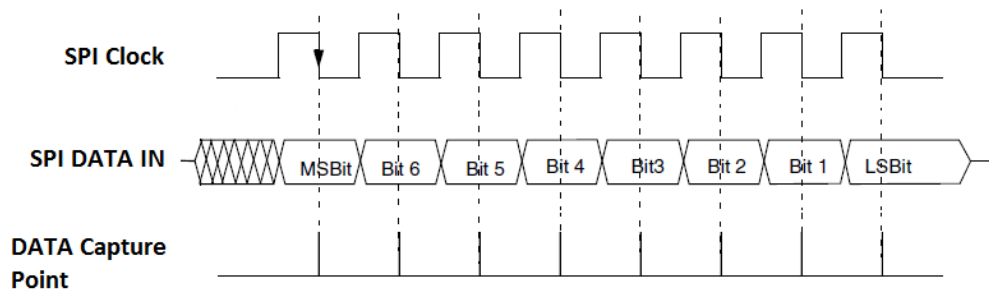

Figure 9: SPI input timing diagram

The data format required for the SPI data as shown in figure 9 is MSB first, positive clock polarity and sampling on the falling edge (second edge) of the clock signal. The maximum SPI clock speed is 1 Mbps.

Note due to the speed of the processor of the Ag320R there is a delay between the complete transmission of a byte from the customer's application and the Ag320R flag going low. The customer should either monitor the flag going low and then back up or wait a minimum of 20uS before checking the communications status flag.

Figure 10 shows an example program code for the users application to interface with the Ag320R communications channel.

Contact Apps support if additional guidance is required.

```

1 while (1) //loop forever
2   {
3     ... //user application code
4     ...
5     ...
6     ...
7     if (comunication_flag_pin == HIGH) //if the flag is high
8     {
9       SPI_SEND_DATA(NEXT_DATA_BYTE); //send the next data byte
10      delay (20us); //wait for sataus pin to clear
11    }
12    ...
13    ...
14    ...
15  }
  
```

Figure 10: Ag320R user application code example

On the Ag320T end when a Byte has been received the byte is presented as an asynchronous serial byte at 9600 bps baud rate, as detailed in section 5.6 of the Ag320T datasheet.

6 Typical Connections

The Ag320R is very easy to implement, Figure 11 shows typical application drawing, giving a basic overview.

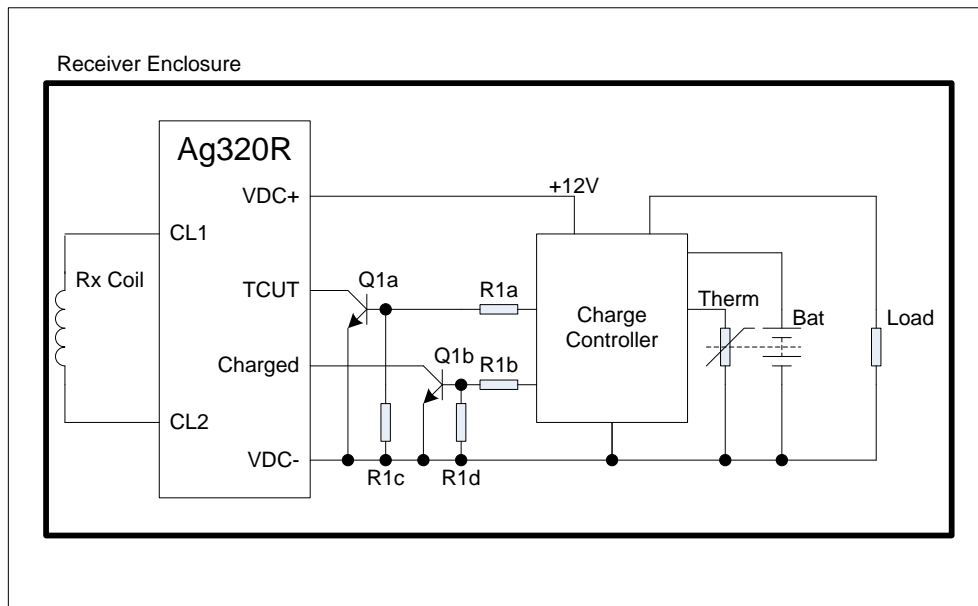

Figure 11: Typical Application Drawing

7 Typical Applications

The Ag320R can be used in a wide range of wireless power and charging applications and with the increased use of mobile & portable devices this list is expanding every day.

At present one of the biggest market sectors for wireless charging are in mobile phones.

But there are many more applications that can benefit from the advantages of wireless power transfer.

Because there are no contacts to cause sparks, wireless charging can be used in environments where combustible materials or gases are present.

Also as the transmitter and receiver can be built into completely sealed enclosures; they can be used in harsh environments, where dust, dirt, water or chemicals are present.

On the other end of the spectrum, wireless power also lends itself for use in clean environments, where disinfecting and sterilization is required.

8 Operating Temperature

The Ag320R has to rectify and regulate the voltage received from the (Ag320T) transmitter. The losses incurred by these processes will result in the module generating heat and as a result this will need to be taken into consideration.

The amount of heat generated by the module is primarily related to the current being drawn by the load. So care needs to be taken to control the ambient temperature around the module.

The Ag320R has a maximum ambient operating temperature of 85 °C, as shown in Figure 12. These results were performed in an environmental chamber (Associated Environmental Systems – SD-302), without any heat-sinking.

The results shown in Figure 12 are relative to the output power drawn from an Ag320R receiver (powered by the Ag320T) with a nominal 4mm coil to coil spacing.

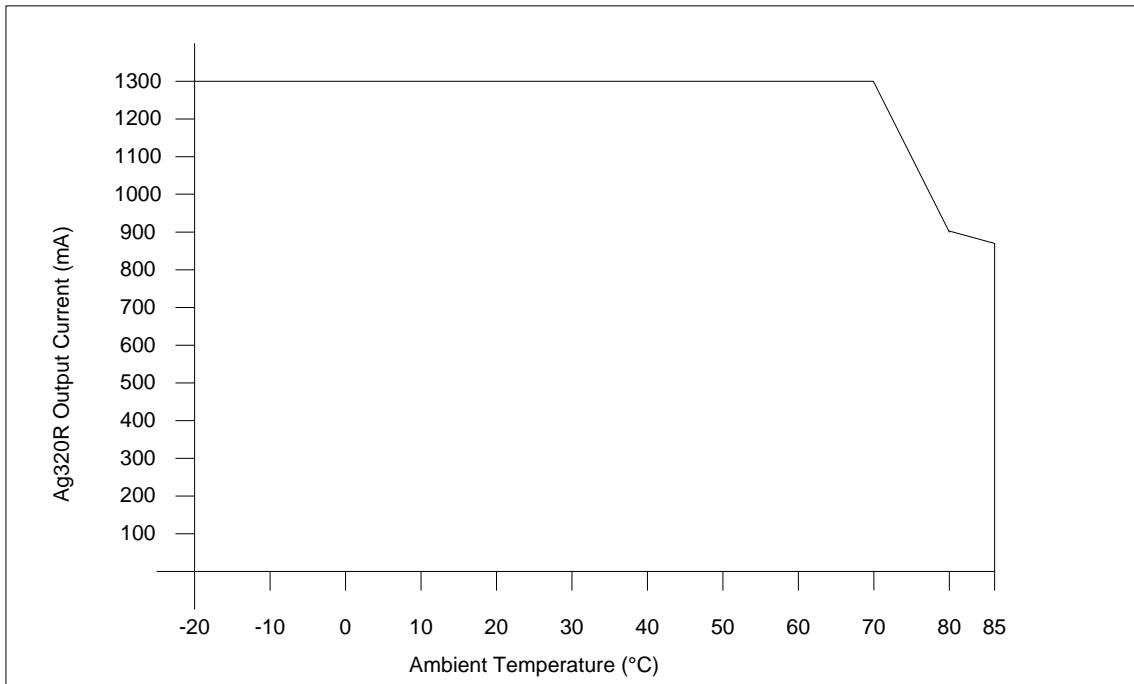

Figure 12: Ag320R Operating Temperature Profile with nominal distance

Further derating of the maximum power transfer occurs with increased power transfer distance. The results shown in Figure 13 are relative to the output power drawn from an Ag320R receiver (powered by the Ag320T) with a maximum 6.5mm coil to coil spacing.

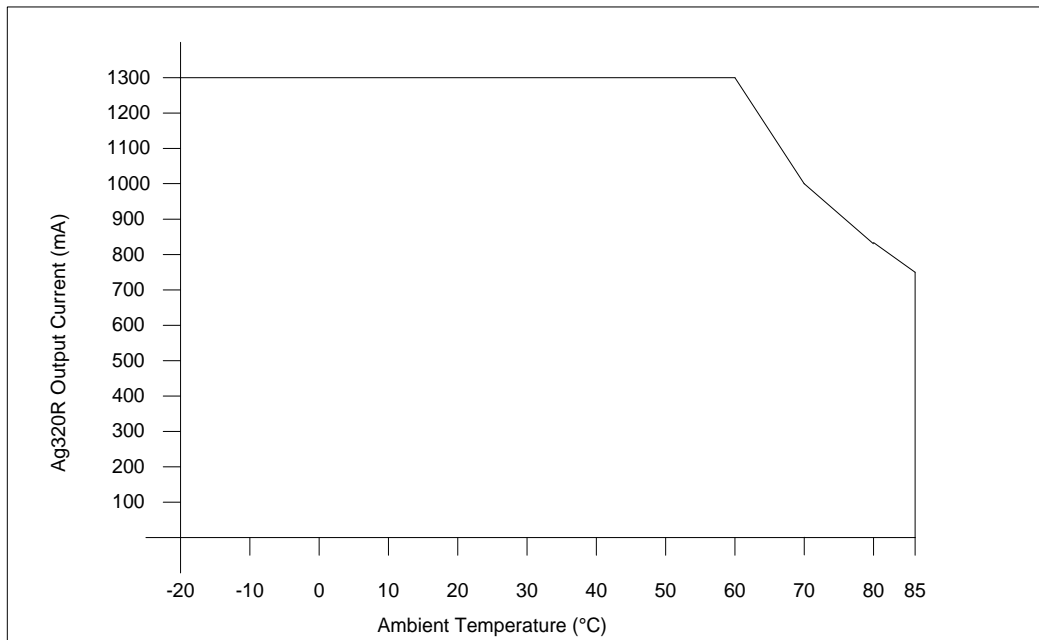

Figure 13: Ag320R Operating Temperature Profile maximum distance

9 Output Protection

9.1 Over Current Protection

The Ag320R output has an over current protection threshold set to ~1.5A. If the load attempt to draw > ~1.5A it will disconnect the output and report an over current error back to the transmitter.

9.2 Short Circuit Protection

The Ag320R output is capable of handling a direct short circuit without any damage to the module.

10 Electrical Characteristics

10.1 Absolute Maximum Ratings*

	Parameter	Symbol	Min	Max	Units
1	Storage Temperature	T_S	-40	+ 100	°C
2	Control Inputs Maximum DC Rating	V_{IN}	-0.3	3.5	V

*Exceeding the above ratings may cause permanent damage to the product. Functional operation under these conditions is not implied. Maximum ratings assume free airflow.

10.2 Recommended Operating Conditions

	Parameter	Symbol	Min	Typ	Max	Units
1	Operating Temperature	T_{OP}	-40	25	+85 †	Ta / °C
2	Maximum Input Voltage (From Coil)	V_{INC}			20	Vp-p

†See Section 8

10.3 DC Electrical Characteristics*

	DC Characteristic	Sym	Min	Typ*	Max	Units	Test Comments
1	Output Voltage	V_{OUT}	11.5	12	12.5	V	@ 50% Load
2	Output Current	I_{OUT}			1.3	A	
3	Over-Load Current	I_{OL}		1.5		A	
4	Load Regulation	V_{REG}		2		%	
5	Peak Efficiency	EFF		72.3		%	With Ag320T
6	Short Circuit Duration	T_{SC}			∞	sec	
7	Minimum Load	I_{MIN}	0			mA	
8	Output Ripple and Noise (Minimum Load) ¹	V_{RN1}		65		mVp-p	

	DC Characteristic	Sym	Min	Typ*	Max	Units	Test Comments
9	Output Ripple and Noise (Maximum Load) ¹	V_{RN2}		105		mVp-p	
10	Maximum Start Up Distance Between Coils	D_{ST}		6.5		mm	@ Full Load
11	Maximum Operating Distance Between Coils	D_{OP}		6.5		mm	@ Full Load
12	Control Inputs Logic Low Voltage	V_{IL}			0.75	V	
13	Control Inputs Logic High Voltage	V_{IH}	2.25			V	

*Typical figures are at 25°C and are for design aid only. Not Guaranteed
 1: This can be reduced with additional output capacitance or filter.

11 Package

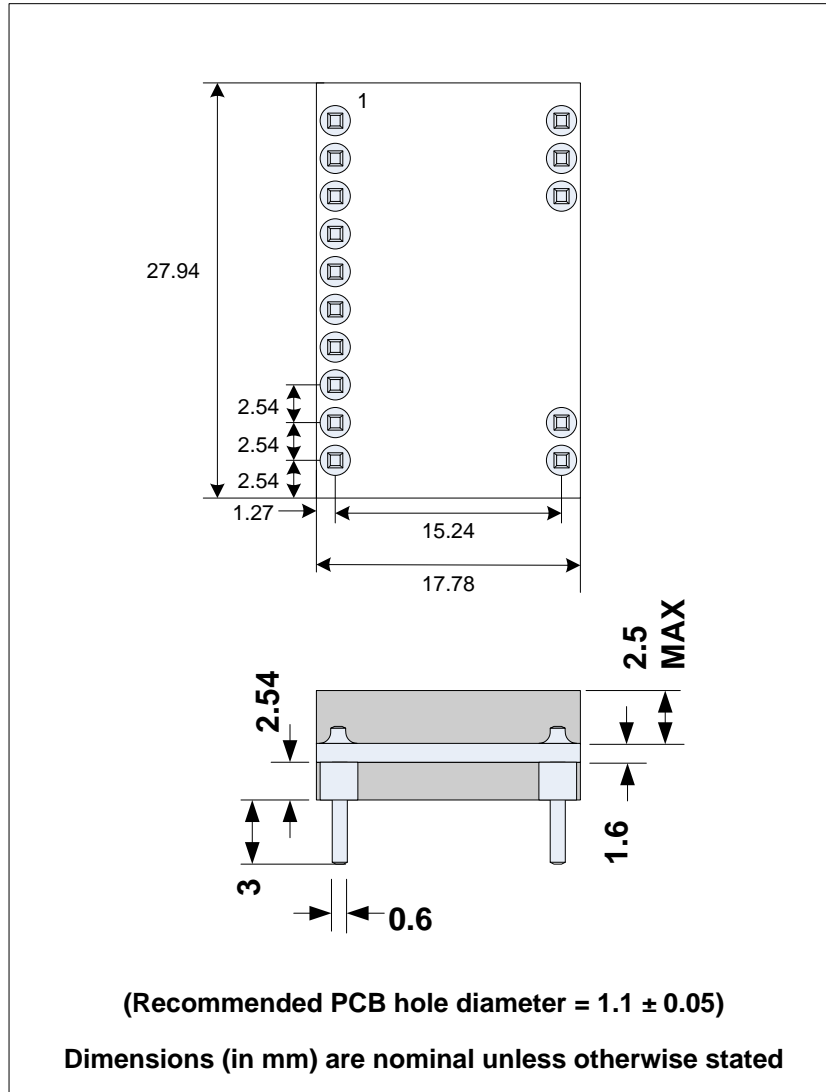

Information published in this datasheet is believed to be correct and accurate. Silver Telecom assumes no liability for errors which may occur or for liability otherwise arising out of use of this information or infringement of patents which may occur as a result of such use. No license is granted by this document under patents owned by Silver Telecom or licensed from third parties by Silver Telecom. The products, their specification and information appearing in this document are subject to change by Silver Telecom without notice.

X-ON Electronics

Largest Supplier of Electrical and Electronic Components

Click to view similar products for [Power Management Modules](#) category:

Click to view products by [Silvertel](#) manufacturer:

Other Similar products are found below :

[FPF1C2P5BF07A](#) [FH2000NPBAP](#) [B0505S-2W](#) [B0305S-1W](#) [B0505S-1WR3](#) [AP24N20-HV](#) [TAD10-1505-NI](#) [TDK30-24S15W](#) [LD03-23B05R2](#) [LD05-23B12R2](#) [URB2415YMD-10WR3](#) [A2409S-1W](#) [IB2412LS-1WR3](#) [IF2405S-1WR3](#) [IB2405S-W75R3](#) [A1205XT-1WR3](#) [A1215XT-1WR3](#) [F1205XT-2WR3](#) [E1215XT-1WR3](#) [E2415XT-1WR3](#) [F1205XT-1WR3](#) [IB1205XT-W75R3](#) [A2405S-1WR2](#) [A1215S-1WR2](#) [A2415S-1WR2](#) [B2405D-1WR3](#) [F1205N-1WR3](#) [F2405N-1WR3](#) [F1205S-2WR3](#) [F2405S-2WR3](#) [HCS2-24S12](#) [HCES1-05S12](#) [HCES1-24S05](#) [HCES1-05D05](#) [HCES1-12D05](#) [HCES2-05D15](#) [HCES2-24D12](#) [HCS1-24D12](#) [HCES2-24S15](#) [UD6-18S15A1](#) [HA25-220S24H2](#) [FD30-18S12B3](#) [IA1205KS-2W](#) [IA2405KS-2W](#) [B1505S-1WX](#) [NV25A12](#) [H14NG03-A05](#) [H14NG03-A12](#) [WG15A05](#) [NJ02-A05L](#)