



1. Features

- Small SIL package
- Suitable for IEEE802.3af compliant PSEs
- Industrial Temperature
- High efficiency (>90%)
- Input voltage range 5V to 15V
- Minimal external components required
- Short-circuit and Thermal protection
- Adjustable Output (36V to 57V)
- 1500V isolation (input to output)
- Silvertel “design-in” assistance

2. Description

The Ag7200 module is a low noise DC/DC boost converter, designed to generate the higher voltages required for IEEE802.3 PSE applications from lower voltage supplies. This module provides exceptional efficiency (>90%) while providing full compatibility with the IEEE 802.3af power and isolation requirements.

The module accepts a wide DC voltage input range, from 5V to 15V. The input voltage is then boosted to generate the higher voltages required to power any IEEE802.3af PSE circuits (including those supplied by Silvertel). The Ag7200 provides a regulated adjustable output, of between 36V and 57V.

Ag7200 has been designed to provide an ideal solution for powering the Silvertel Ag6100 PSE module from a vehicle battery, 12V plug-top PSU or other commonly available power supplies. Its low cost, small footprint, high efficiency and in-built isolation make it an extremely versatile DC-DC boost converter for a wide range of potential applications.

Table of Contents

1. Features	1
2. Description.....	1
Table of Contents	2
Table of Figures	2
3. Ag7200 Product Selector.....	3
4. Pin Description	4
4.1 Ag7200	5
5. Functional Description	6
5.1 Input	6
5.2 Output.....	6
5.3 Isolation	6
5.4 DC/DC Converter	7
5.5 Output Adjustment.....	7
5.6 Typical Connections	7
6. Layout Consideration.....	8
7. Operating Temperature Range	9
8. Protection	10
8.1 Output Protection.....	10
8.2 Thermal Protection	10
9. EMC.....	10
10. Electrical Characteristics.....	11
10.1 Absolute Maximum Ratings ¹	11
10.2 Recommended Operating Conditions.....	11
10.3 DC Electrical Characteristics	11
11. Package	12

Table of Figures

Figure 1: Block Diagram	3
Figure 2: Ag7200 Package Format	4
Figure 3: Typical System Diagram	6
Figure 4: Output Adjustment	7
Figure 5: Typical Connection Diagram.....	8
Figure 6: Layout Consideration	8
Figure 7: Ag7200 Operating Profile	9
Figure 8: Ag7200 Output Protection	10

3. Ag7200 Product Selector

Part Number†	Output Voltage	Maximum Output Power *	Date code‡
Ag7200	36V to 57V	20 Watts	WWYY

*At 25°C with $V_{IN} = 12V$

† The Ag7200 fully meets the requirements of the RoHS directive 2011/65/EC on the restriction of hazardous substances in electronic equipment.

‡ Date code format: "WW" = Week Number, "YY" = Year.

Table 1: Ordering Information

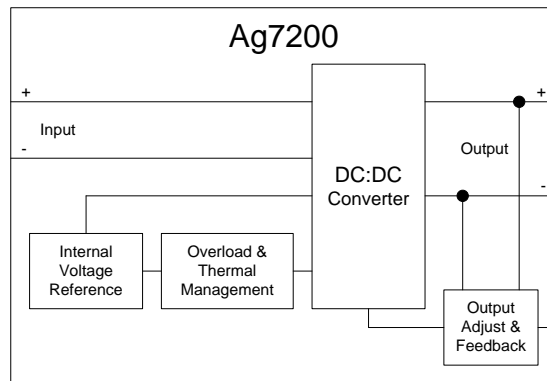

Figure 1: Block Diagram

4. Pin Description

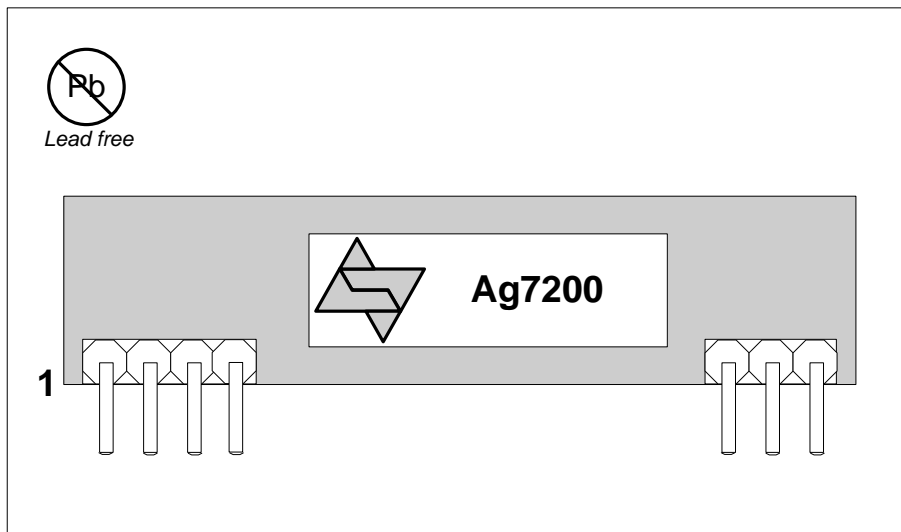

Figure 2: Ag7200 Package Format

4.1 Ag7200

Pin #	Name	Description
1	VIN+	Direct Input +. These pins connect to the positive (+) output of the power supply.
2		
3	VIN -	Direct Input -. These pins connect to the negative (-) output of the power supply.
4		
5	-VDC	DC Return. This pin is the return path for the +VDC output.
6	ADJ	Output Adjust. The output voltage can be adjusted up or down from its nominal value of 48V. This can be done by connecting an external resistor from this pin to the – VDC or +VDC pins.
7	+VDC	DC Output. This pin provides the regulated output from the DC/DC converter.

Table 2: Pin Description

5. Functional Description

5.1 Input

The Ag7200 has a wide input voltage range of 5Vdc to 15Vdc; as shown in Figure 3.

Depending on the length of lead and decoupling of the power supply being used the customer may need to connect an electrolytic capacitor across the Ag7200 input which will reduce the ripple from the supply.

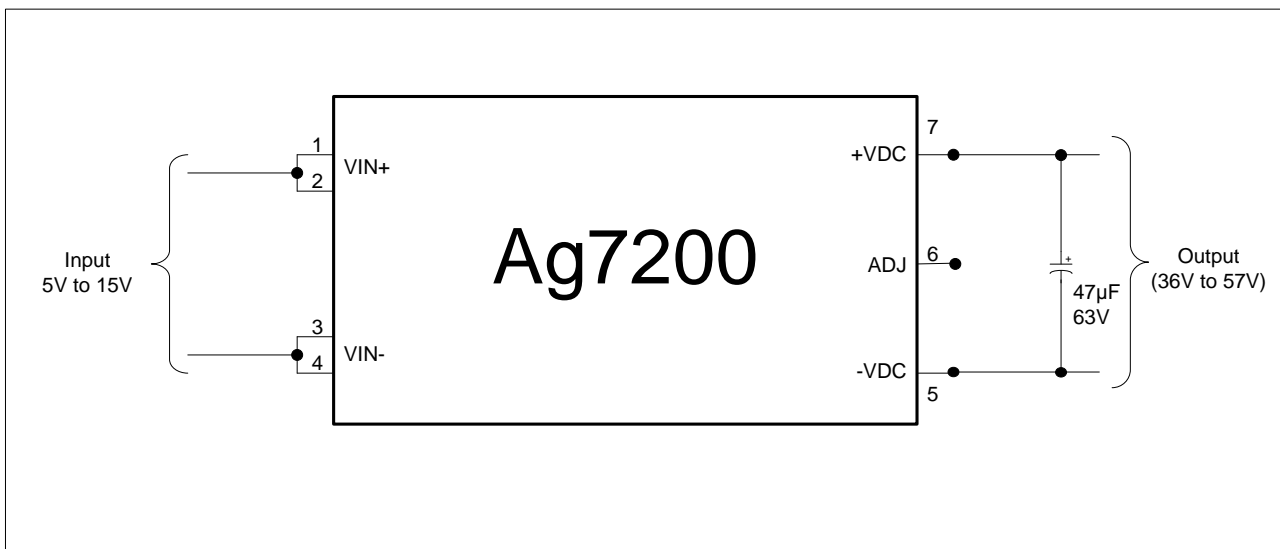

Figure 3: Typical System Diagram

5.2 Output

The Ag7200 output must have an external 47µF 63V electrolytic capacitor fitted as close as possible to the output pins. It functions as part of the output filter and is required to reduce the DC/DC converter switching noise and output ripple.

To reduce the output ripple and noise further, we would recommend using a low ESR electrolytic. Also a low ESR capacitor is essential for operation below 0°C.

5.3 Isolation

To meet the safety isolation requirements of Power over Ethernet (PoE); the Ag7200 has been designed to meet the 1500Vdc impulse test*. It is also important that the tracks on either side of the isolation barrier also have at least a 3mm clearance, see Figure 6 in Section 6 for more information.

*Note: The impulse test is defined in the following specifications: -
IEEE802.3af section 33.4.1 option b

5.4 DC/DC Converter

The Ag7200 DC/DC converter provides a regulated output that has built-in over temperature and output short-circuit protection.

5.5 Output Adjustment

The Ag7200 has a nominal output voltage of 48V. This can be adjusted down to a minimum of 36V by fitting a 260K resistor between the ADJ and +VDC pins, alternatively the output voltage can be adjusted up to a maximum of 57V by fitting 0 Ohm resistor between ADJ and -VDC.

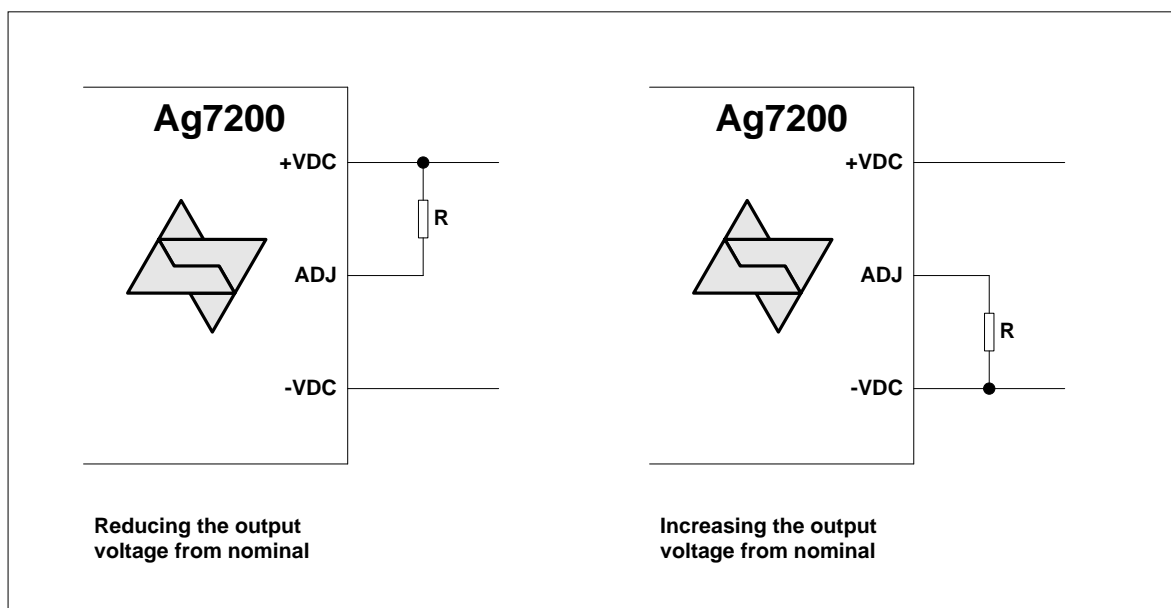

Figure 4: Output Adjustment

Reducing the output voltage, connect R between ADJ and +VDC	
Value of R	Ag7200 Output
260K	36V
Increasing the output voltage, connect R between ADJ and -VDC	
Value of R	Ag7200 Output
0 Ohms	57V

Table 3: Output Adjustment Resistor (R) Value

5.6 Typical Connections

The Ag7200 requires minimal external components as shown in Figure 5.

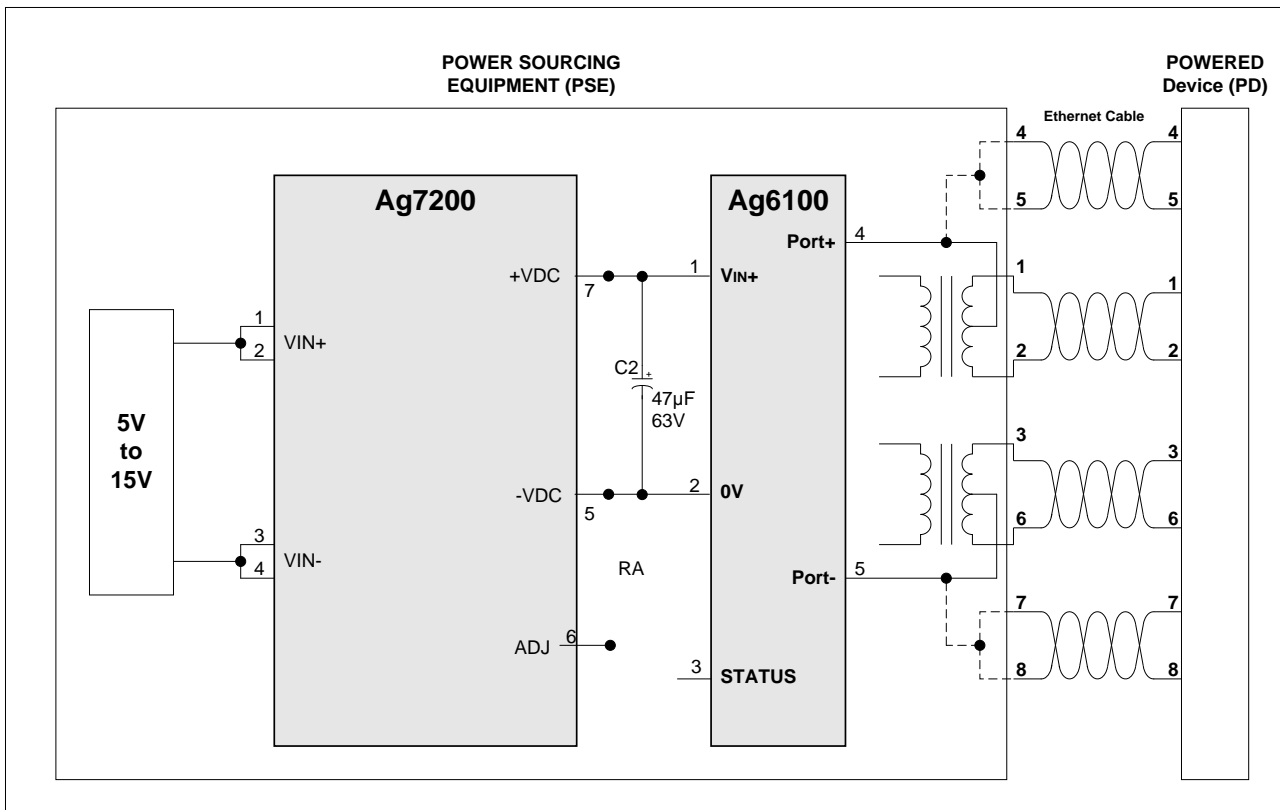

Figure 5: Typical Connection Diagram

6. Layout Consideration

Figure 6 shows our suggested board layout for the Ag7200, with reference to the typical connection diagram shown in Figure 5.

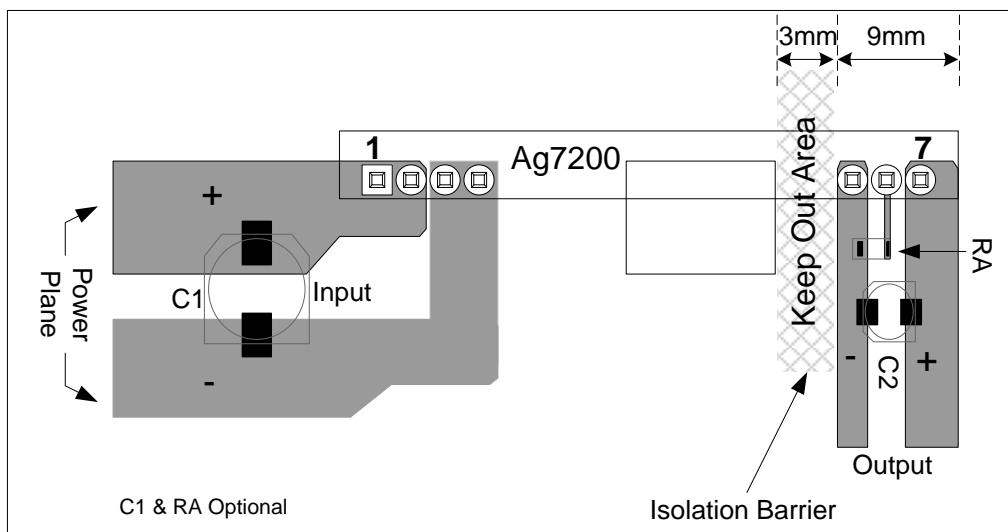

Figure 6: Layout Consideration

It is important that tracks (on the top layer) and through hole vias are not placed in the “Keep Out Area” shown in Figure 6. This area is required to maintain the integrity of the isolation barrier, described in Section 5.3.

7. Operating Temperature Range

Because the Ag7200 is a power component, it will generate heat; so it is important that this be taken into consideration at the design stage.

The heart of the Ag7200 is a DC/DC converter, which like any other power supply will generate heat. The amount of heat generated by the module will depend on the load it is required to drive and the input voltage supplied.

The Ag7200 has a maximum ambient operating temperature of 85°C; but the maximum power is limited by the input voltage, see Figure 7. These results were performed in an environmental chamber - Associated Environmental System SD-302, without any heat-sinking. The performance of the Ag7200 can be improved by forcing the airflow directly over the part or by using thermal relief pads to draw heat away from the module.

The Ag7200 does have thermal protection; but it is important that the maximum operating temperature is never exceeded.

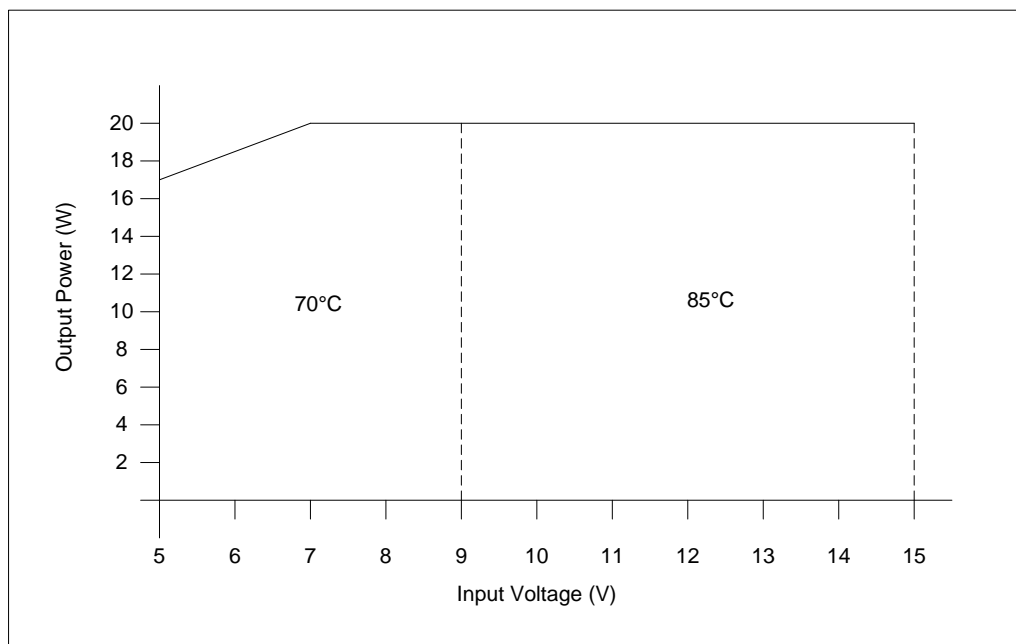

Figure 7: Ag7200 Operating Profile

One simple technique that can be used to draw heat away from the module is to add power planes to the input and output pins as shown in Figure 6.

Due to the small size of the Ag7200, it is important that as much heat is drawn away from the module as possible. It is also important that any enclosure used has sufficient ventilation for the Ag7200 and a direct airflow if possible. But because each application is different, it is impossible to give fixed and absolute thermal recommendations.

8. Protection

8.1 Output Protection

The Ag7200 output must be protected from over-voltages exceeding the 80V maximum rated surge voltage. An inexpensive but effective solution can be achieved by connecting a Tranzorb diode across the output; see Figure 8.

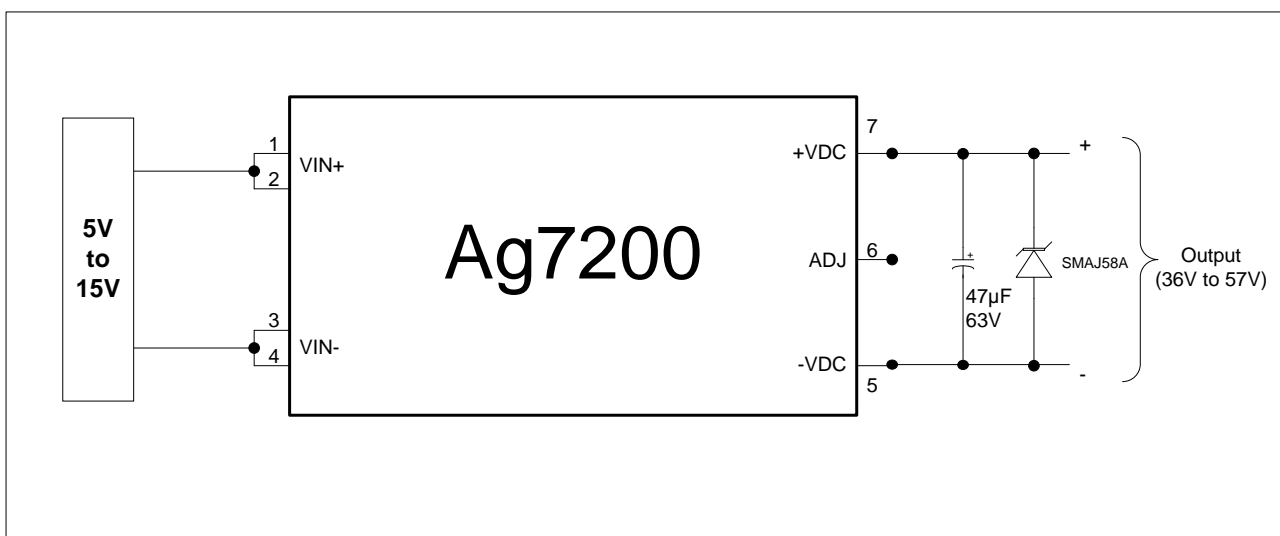

Figure 8: Ag7200 Output Protection

8.2 Thermal Protection

The Ag7200 has built-in thermal protection as standard.

When the thermal protection is tripped, the dc/dc converter will be shutdown for ~2 seconds. After this duration the dc/dc converter will be turned back on and the temperature retested. If the temperature is still too high, it will repeat this process until the temperature falls to within the modules operating parameter.

9. EMC

The Ag7200 is designed to meet EN55032 Class B (pre-compliance test results are available from Silvertel).

However, because the Ag7200 will only be one component within your system, it is impossible to say whether the final product will pass EMC testing, without the need for additional filtering.

10. Electrical Characteristics

10.1 Absolute Maximum Ratings¹

	Parameter	Symbol	Min	Max	Units
1	DC Supply Voltage	V_{CC}	4.5	15.5	V
2	Surge Voltage at Output (for 1ms)	V_{SURGE}	-0.6	80	V
3	Storage Temperature	T_S	-40	+100	°C

Note 1: Exceeding the above ratings may cause permanent damage to the product. Functional operation under these conditions is not implied. Maximum ratings assume free airflow.

10.2 Recommended Operating Conditions

	Parameter	Symbol	Min	Typ	Max	Units
1	Input Supply Voltage ¹	V_{IN}	5	12	15	V
2	Operating Temperature ¹	T_{OP}	-40	25	85	T_a / °C

Note 1: See Section 7.

10.3 DC Electrical Characteristics

	DC Characteristic	Sym	Min	Typ ¹	Max	Units	Test Comments
1	Nominal Output Voltage	+VDC	46.8	48	49.2	V	
2	Peak Output Power ²	I_{LOAD}			20 16.8	W W	@ >9Vin @ 5Vin
3	Line Regulation	V_{LINE}		0.035		%	
4	Load Regulation - Min to Max	V_{LOAD}		0.1		%	
5	Output Ripple and Noise ³	V_{RN}		270		mVp-p	
6	Minimum Load	I_{MIN}	0			mA	
7	Short-Circuit Duration	T_{SC}			∞	sec	
8	Peak Efficiency	EFF		90.0		%	
9	Isolation Voltage (I/O)	V_{ISO}			1500	V_{PK}	Impulse Test

Note 1: Typical figures are at 25°C with a nominal output voltage = 48V and are for design aid only. Not Guaranteed.

2: See Section 7

3: Measurements made on a Picoscope 3205A with a 200MHz (x10) probe.

11. Package

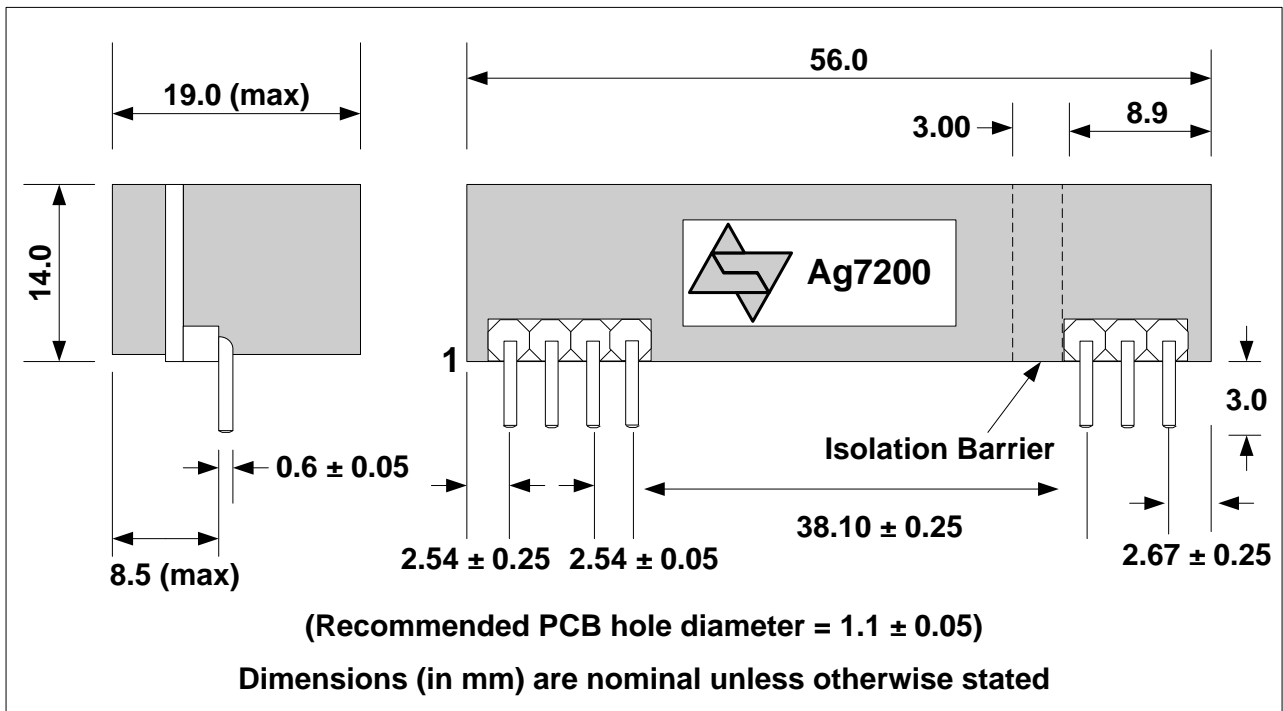

Information published in this datasheet is believed to be correct and accurate. Silver Telecom assumes no liability for errors which may occur or for liability otherwise arising out of use of this information or infringement of patents which may occur as a result of such use. No license is granted by this document under patents owned by Silver Telecom or licensed from third parties by Silver Telecom. The products, their specification and information appearing in this document are subject to change by Silver Telecom without notice.

X-ON Electronics

Largest Supplier of Electrical and Electronic Components

Click to view similar products for [Isolated DC/DC Converters](#) category:

Click to view products by [Silvertel](#) manufacturer:

Other Similar products are found below :

[049398D](#) [050047H](#) [06322](#) [079487E](#) [088-101348-G](#) [0RCY-60U12CG](#) [0RQB-30Y05L](#) [0RQB-30Y05LG](#) [0RQB-C5W24RG](#) [1046800](#)
[1046803](#) [1091527](#) [110IMX35D05D05-8G](#) [110IMX35D15D15-8G](#) [110IMX7-15-15-8G](#) [110IMX7-24-24-8G](#) [110IMY70-05-0TG](#) [110IMY70-](#)
[05-0TZG](#) [110IMY70-12-0TG](#) [110IMY70-12-0TZG](#) [110IMY70-15-0TG](#) [110IMY70-15-0TZG](#) [110IMY70-24-24-0G](#) [110IMY70-24-24-0ZG](#)
[110RCM150-12DMQFK](#) [110RCM150-24DF](#) [110RCM150-24DMQF](#) [110RCM300-24DMQF](#) [13DS1-05S05NNL](#) [15EFL24-24W-I/O-RB](#)
[15FL12-12W-I/O](#) [177920501](#) [177920521](#) [177920524](#) [177920531](#) [18368](#) [18371](#) [18372](#) [18379](#) [19126](#) [19-130041](#) [20IMX15-0503-8RG](#)
[20IMX15-15-15-8-G](#) [20IMX35D05D05-8G](#) [20IMX35D05D15-8G](#) [20IMX35D15D15-8](#) [20IMX4-0505-8KG](#) [20IMX4-1212-8](#) [20IMX4-12-8](#)
[20IMX4-1515-8G](#)