



**Ag117x Evaluation Board  
User Manual**

Rev 1.0 – March 2007

<b>1</b>	<b>Introduction</b>	<b>2</b>
<b>2</b>	<b>Board Description</b>	<b>2</b>
2.1	<i>Board Power</i> .....	4
2.2	<i>Power Options</i> .....	4
2.3	<i>Impedance Programming Options</i> .....	5
<b>3</b>	<b>Getting Started</b>	<b>6</b>
3.1	<i>Equipment Required</i> .....	6
3.2	<i>Link Settings</i> .....	7
<b>4</b>	<b>Using the Board</b>	<b>8</b>
4.1	<i>Power On Conditions</i> .....	8
4.2	<i>Ringing the Phone</i> .....	8
4.3	<i>Dial Tone</i> .....	8
4.4	<i>Reset</i> .....	9
<b>5</b>	<b>Using Two Ag117x Evaluation Boards</b>	<b>9</b>
5.1	<i>Set-up Conditions</i> .....	9
5.2	<i>Talking Between the Two Telephones</i> .....	9
5.3	<i>Ringing the Phone</i> .....	10
<b>6</b>	<b>Using Two Ag117x Evaluation Boards via a CODEC</b>	<b>10</b>
6.1	<i>Set-up Conditions</i> .....	10
6.2	<i>Operation</i> .....	11
<b>7</b>	<b>Using an Ag117x and Ag21x0 Evaluation Boards</b>	<b>11</b>
7.1	<i>Set-up Conditions</i> .....	11
7.2	<i>Ringing the Phone</i> .....	12
7.3	<i>Making a Call</i> .....	12
<b>8</b>	<b>Using the Ag117x and Ag21x0 via a CODEC board</b>	<b>13</b>
8.1	<i>Set-up Conditions</i> .....	13
8.2	<i>Operation</i> .....	13
<b>9</b>	<b>Other Options</b>	<b>14</b>
9.1	<i>RM and FR Links</i> .....	14
9.2	<i>Programming the Microcontroller</i> .....	15

## 1 Introduction

This manual is intended to be a guide to using the Ag117x evaluation board. This board can be used on its own (with a telephone), or used in conjunction with other Silver Telecom evaluation boards. Examples of the different set-ups that can be used are show within this user manual.

Below is a list of Silver Telecom SLIC (Subscriber Line Interface Circuit) modules that can be used on the Ag117x evaluation board: -

Ag1170 – All product variants

Ag1171

## 2 Board Description

The board has two SLIC sockets, one for the single-in-line (SIL) and one for the dual-in-line (DIL). Do not attempt to plug in both variant at the same time.

There are two 25-way D-Type connectors (J1 socket and J2 plug) that can be used to connect this board to other evaluation boards. There is also an RJ11 connector J3 to connect a telephone (to TIP and RING) and a power connector J6 to connect to a 7.5V bench power supply or power pack.

The board is controlled by a Microchip 16F88 microcontroller, which is programmed via J4; a copy of the .asm file is available upon request. The software has been developed solely to demonstrate the different functions of the products listed above.

The board uses an LM324 to generate a simple dial tone (350Hz & 440Hz). There are multiple test points and several links that can be used to monitor or inject external signals.

The microcontroller monitors the SHK output and controls the FR, RM and SYNC inputs. In addition to this the controller also monitors the three control buttons: - Ring, Tone and Master Reset and two external lines connected to J1 and J2.



## 2.1 Board Power

The power socket J6 accepts an input voltage\* range of 7.5V to 9V, the supply needs to be capable of supply to 1 Amp. The Ag117x evaluation kit has a power pack included, but if a different power supply is going to be used then it is important that it meets the above criteria and the centre pin is positive (+).

\* The power input is polarity protected.

## 2.2 Power Options

The board is powered from the on-board regulator and can be set to +5V or +3.3V by using LK1 (see Figure 2): -

+5V - LK1 not fitted

+3.3V - LK1 fitted

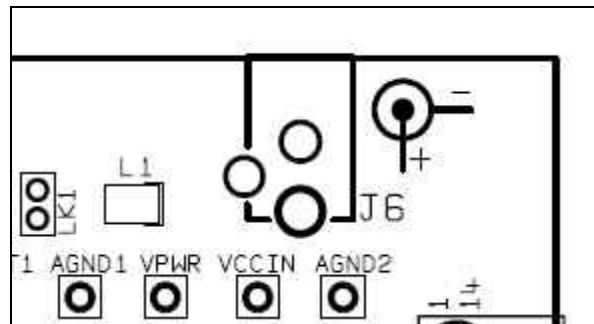

Figure 2: Power Input

### 2.3 Impedance Programming Options

When using a programmable SLIC such as the Ag1170P, an impedance module must be fitted in J5 (see Figure 3). However when using a standard SLIC (where the impedance is fixed to 600R) the impedance module must not be fitted in J5.

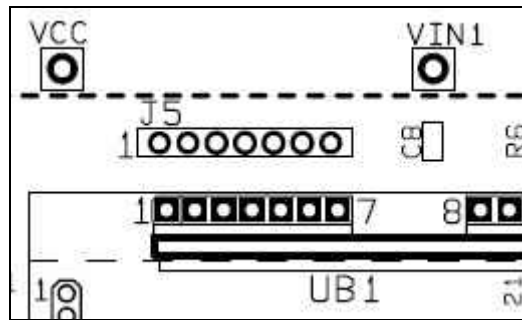

Figure 3: Impedance Module Position

The impedance modules are not supplied with the standard Ag117x evaluation board (or kit), but are available upon request. The module shown in Figure 4 can be made to match various Network and Terminal Impedances, see the Ag1170P applications note AN1170-1 for the component values required.

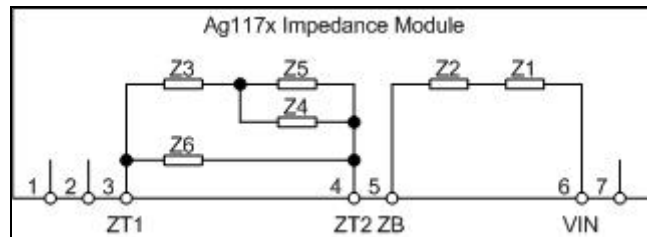

Figure 4: Impedance Module Connections

## 3 Getting Started

### 3.1 Equipment Required

Figure 5 shows a basic set up using a single Ag117x evaluation board and a telephone.

The equipment required: -

- Ag117x Evaluation Board
- PSU 7.5V @ 1 Amp (supplied in kit only)
- Telephone

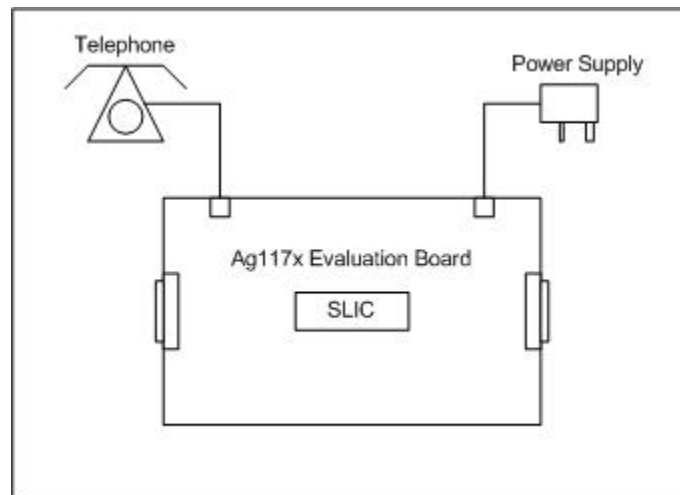

Figure 5: Basic set-up

### 3.2 Link Settings

LK7 to LK10 are used to set the Ag117x evaluation board for the different SLIC variants, see Figure 6 and Table 1 below.

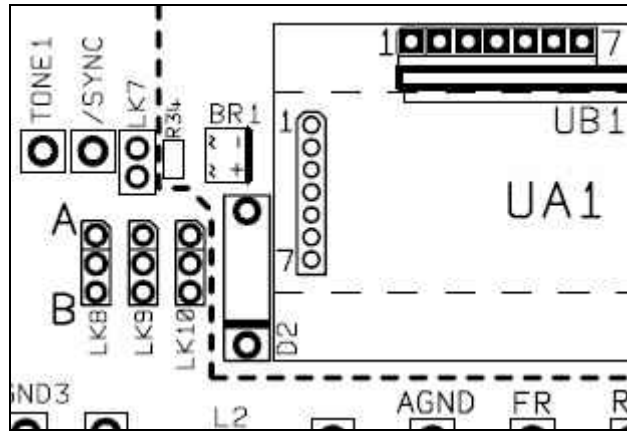

Figure 6: Product Link Positions

Product	LK7	LK8	LK9	LK10
Ag1170	Not Fitted	Position A	Position A	Position A
Ag1171	Fitted	Position B	Position B	Position B

Table 1: Product Link Settings



## 4 Using the Board

### 4.1 Power On Conditions

When the Ag117x evaluation board is connected as shown in Figure 6, with the phone On-Hook, on power-up the board will default to the conditions shown in Table 2 (idle state).

Pin	Status	LED
SYNC	Free run	Power = ON
RM	Logic 0	RM = OFF
F/R	Logic 1	F/R = ON
		SHK = OFF
		Tone = OFF

Table 2: Default Condition

### 4.2 Ringing the Phone

With the telephone On-Hook press and release the “RING” button to ring the phone. When the phone is ringing the RM LED will be ON (for approximately 1 second) and OFF (for approximately 3 seconds). The FR LED will toggle (ON and OFF) at 20Hz during ringing (when RM is ON) and FR will be ON between rings (when RM is OFF).

The ringing will stop automatically, when the SLIC detects the phone going Off-Hook, or ringing can be cancelled by pressing either the “Tone” or “Master Reset” buttons.

If the phone is already Off-Hook and the “RING” button is pressed, the phone will not ring.

### 4.3 Dial Tone

When the phone goes “Off-Hook” the dial tone circuit is enabled. When the “TONE” button is pressed, the evaluation board will generate a dial tone audible in the earpiece. This can be toggled ON and OFF by pressing and releasing the “TONE” button, the status will be indicated by the TONE LED.

## 4.4 Reset

The SLIC can be reset, by pressing the “MASTER-RESET” button. This will take the SYNC pin to Logic 0 and reset the board controller back to the Power ON condition.

# 5 Using Two Ag117x Evaluation Boards

## 5.1 Set-up Conditions

Two Ag117x evaluation boards can be connected together as shown in Figure 8. Each board can be operated independently as shown in section 4.

The boards can be operated with a single power supply, in Figure 7 the power supply is connected to board “B”, but it would work equally well if the power supply was connected to board “A”.

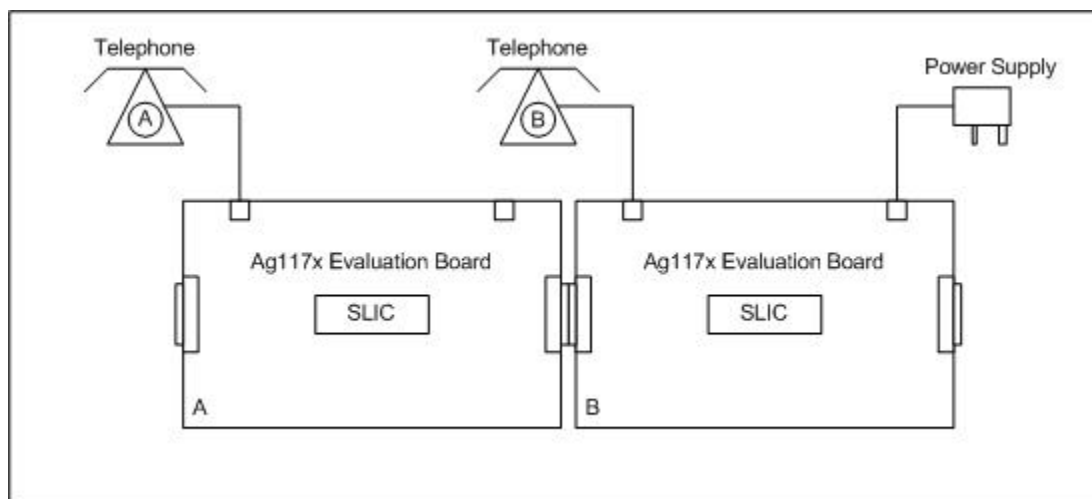

Figure 7: Connecting Two Ag117x Evaluation Boards

## 5.2 Talking Between the Two Telephones

Two Ag117x evaluation boards can be connected together via their 25 way male and female D-Type connectors. To have a conversation between telephones “A” and “B” (as shown in Figure 7) is done by simply going Off-Hook on both telephones.

If the audio is too loud this can be attenuated by 6dB by placing a jumper link across LK3, Figure 8 shows this in more detail.

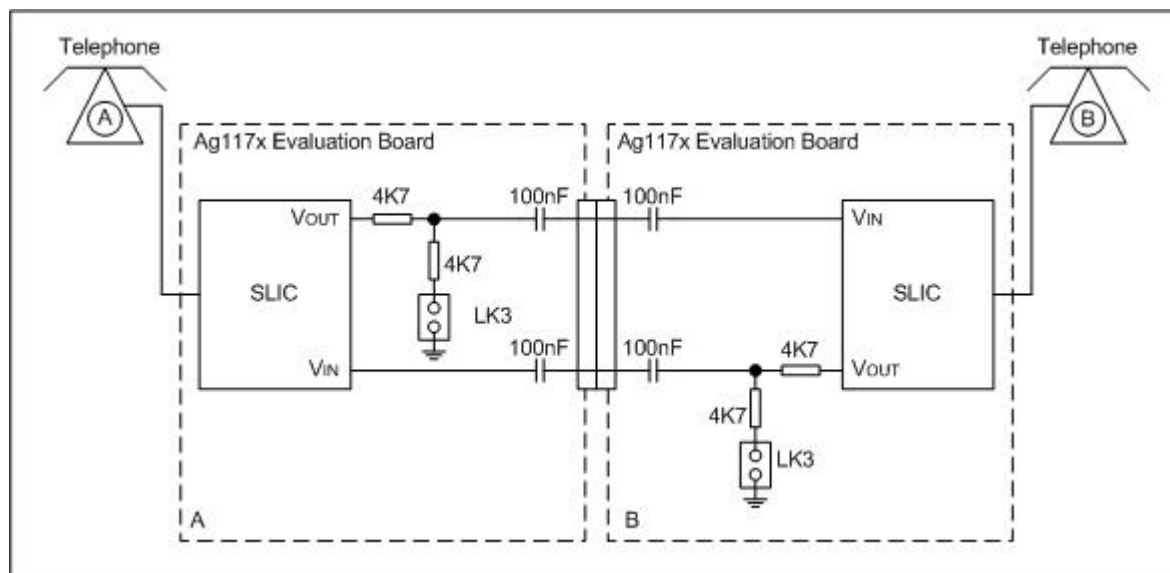

Figure 8: Connecting Two Ag1170 Evaluation Boards

### 5.3 Ringing the Phone

When two Ag117x evaluation boards are connected together as shown in Figures 7 and 8, if telephone “A” is On-Hook and the “RING” button is pressed (on evaluation board “A”) then telephone “A” will ring (the same applies with telephone “B” and board “B”).

If telephone “A” is Off-Hook and the “RING” button is pressed (on board “A”), providing telephone “B” is On-Hook, that telephone will ring. Telephone “B” will stop ringing as soon as it goes Off-Hook, the ringing can also be cancelled by pressing either the “TONE” or “MASTER-RESET” buttons on board “A”. The reverse also applies if telephone “B” is off-hook and the “RING” button is pressed (on board “B”).

## 6 Using Two Ag117x Evaluation Boards via a CODEC

### 6.1 Set-up Conditions

Two Ag117x evaluation boards can be connected together via a CODEC as shown in Figure 9. Each board can be operated independently as shown in section 4.

The boards can be operated with a single power supply, in Figure 9 the power supply is connected to board “B”, but it would work equally well if the power supply was connected to board “A”.

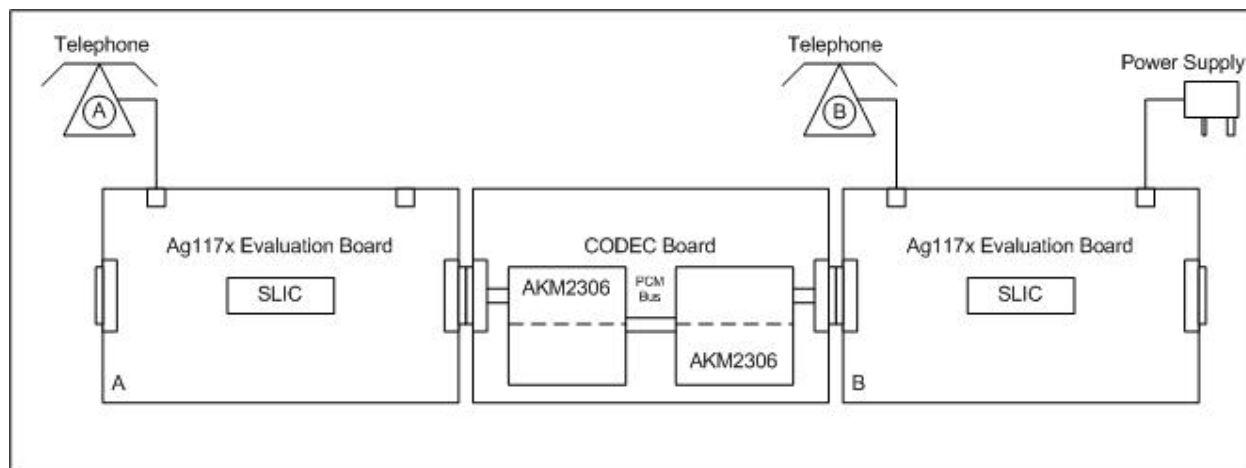

Figure 9: Connecting Two Ag117x Evaluation Boards via a CODEC

## 6.2 Operation

The operation of the Ag117x evaluation boards are no different from that detailed in Sections 4 and 5.

# 7 Using an Ag117x and Ag21x0 Evaluation Boards

## 7.1 Set-up Conditions

The Ag117x evaluation board can be connected to an Ag21x0 evaluation board (Ag2120 evaluation board or Ag2130 evaluation board) as shown in Figure 10.

The boards can be operated with a single power supply in Figure 10 the power supply is connected to board "A". This is the optimum configuration as the Ag117x evaluation board draws more supply current than the Ag21x0 evaluation board.

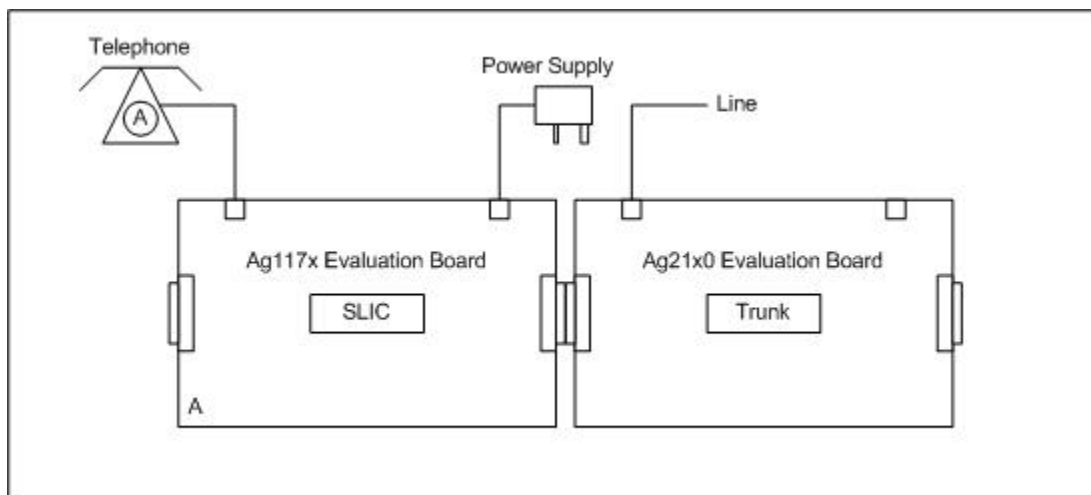

Figure 10: Connecting an Ag117x and Ag21x0 Evaluation Boards

## 7.2 Ringing the Phone

When the Ag117x evaluation boards is connected to an Ag21x0 evaluation board, if telephone “A” is On-Hook and the “RING” button is pressed then telephone “A” will ring.

If an external call is made to the “Line” connected to the Ag21x0 evaluation board, this board will signal the Ag117x board and telephone “A” will ring. When telephone “A” goes Off-Hook, the ringing will automatically stop and the Ag117x board will instruct the Ag21x0 board to seize the line (accepting the call).

## 7.3 Making a Call

If both evaluation boards are in their idle state, when telephone “A” goes Off-Hook the dial tones should be audible.

To make a call dial the number required from telephone “A” and when the connection is made the ring tone (or engaged tone) will be heard. When the far end phone goes Off-Hook the audio paths will be connected, if the audio level is too high (at the far end) the LK3 can be fitted to reduce this by 6dB.

## 8 Using the Ag117x and Ag21x0 via a CODEC board

### 8.1 Set-up Conditions

The Ag117x evaluation boards can be connected to an Ag21x0 evaluation board via a CODEC board as shown in Figure 11. Each board can be operated independently as shown in section 4.

The boards can be operated with a single power supply in Figure 11 the power supply is connected to board “A”. Because the Ag117x evaluation board draws the most power supply current, this is the optimum configuration.

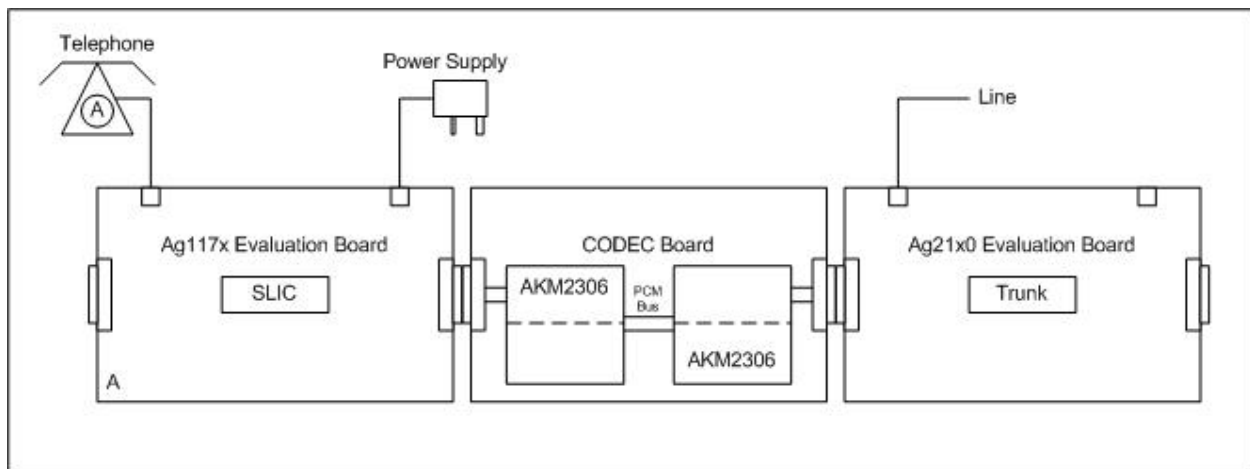

Figure 11: Connecting an Ag117x, Ag21x0 and CODEC Boards

### 8.2 Operation

The operation of the Ag117x evaluation board when used with the Ag21x0 and CODEC board is no different from that detailed in Section 7.

## 9 Other Options

### 9.1 RM and FR Links

The RM and FR inputs can be isolated from the on-board controller by removing LK2 for RM or LK6 for FR.

The top pins of LK2 and LK6 connect to the SLIC and the bottom pins connect to the controller (see Figure 12).

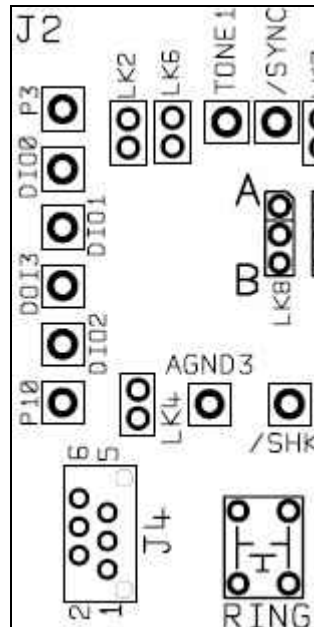

Figure 12: Other Links

## 9.2 Programming the Microcontroller

The microcontroller can be programmed in-circuit. To do so ensure that the SLIC and links LK2 and LK4 are removed, then connect the programmer to J4 (see Table 3 for pin connection details).

If the programmer does not supply its own power then remove link LK1 (setting the board to +5.0V) and connect the (+7.5V) power supply to J6. If the programmer does supply its own power, then disconnect the power supply connected to J6 and remove link LK4 (in addition to LK2 and LK6).

1	2	3	4	5	6
V <sub>PP</sub>	PGD	PGC	V <sub>DD</sub>	V <sub>SS</sub>	V <sub>SS</sub>

Table 3: J4 Programming Pin Connections

Silver Telecom Ltd does not accept responsibility for any damage to the Ag117x evaluation board or product, resulting from third party changes made to the software provided.



## X-ON Electronics

Largest Supplier of Electrical and Electronic Components

*Click to view similar products for [Interface Development Tools](#) category:*

*Click to view products by [Silvertel](#) manufacturer:*

Other Similar products are found below :

[ADP5585CP-EVALZ](#) [CHA2066-99F](#) [AS8650-DB](#) [416100120-3](#) [XR18910ILEVB](#) [XR21B1421IL28-0A-EVB](#) [EVAL-ADM2491EEBZ](#)  
[MAXREFDES23DB#](#) [MAX13235EEVKIT](#) [DFR0257](#) [XR22404CG28EVB](#) [ZLR964122L](#) [ZLR88822L](#) [DC327A](#) [PIM511](#) [PIM536](#) [PIM517](#)  
[DEV-17512](#) [STR-FUSB3307MPX-PPS-GEVK](#) [ZSSC3240KIT](#) [P0551](#) [MAX9121EVKIT](#) [PIM532](#) [ZSC31010KITV2P1](#) [MIKROE-2335](#)  
[XR20M1172G28-0B-EB](#) [1764](#) [1833](#) [1862](#) [EVB-USB82514](#) [ATA6628-EK](#) [EVAL-CN0313-SDPZ](#) [2264](#) [MCP23X17EV](#) [PS081-EVA-HR](#)  
[MODULE](#) [237](#) [SMA2RJ45EVK/NOPB](#) [FR12-0002](#) [MAFR-000455-001](#) [BOB-13263](#) [CPC5622-EVAL-600R](#) [SKYFR-000743](#) [SKYFR-](#)  
[000827](#) [SKYFR-000982](#) [MIKROE-2750](#) [292](#) [DFR0065](#) [DFR0077](#) [TEL0010](#) [TEL0038](#)