

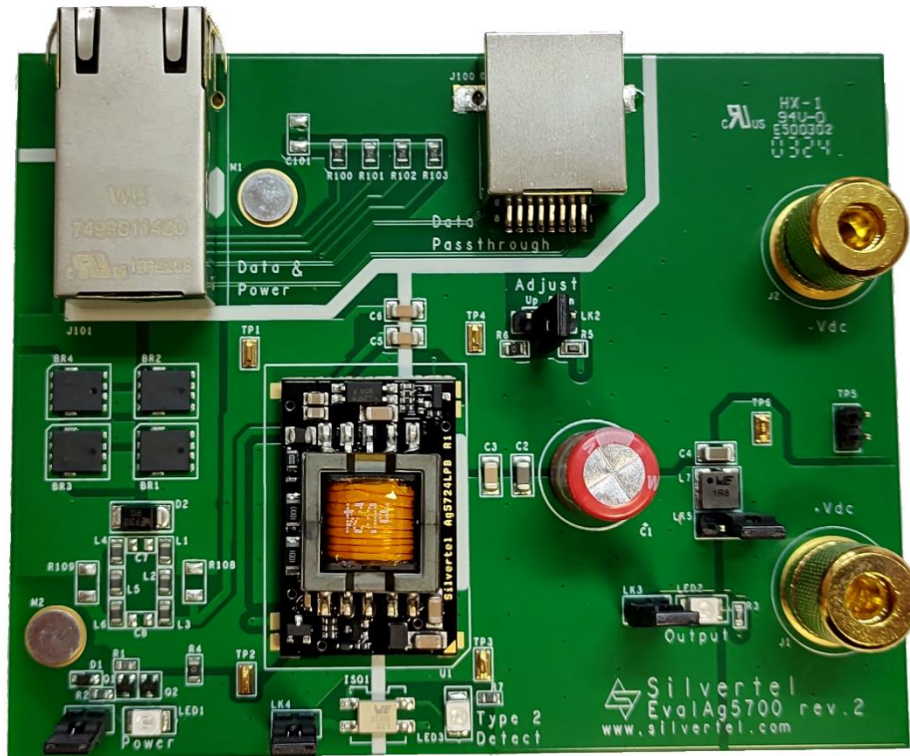

# Evaluation Board User Manual



## EvalAg5700 Evaluation Board User Manual

Version 2.0 – May 2024

## Table of Contents

<b>1</b>	<b>Kit Contents</b> .....	<b>3</b>
<b>2</b>	<b>Board Layout</b> .....	<b>3</b>
2.1	Link Settings .....	3
2.2	Input Output Connections.....	3
<b>3</b>	<b>Introduction</b> .....	<b>4</b>
<b>4</b>	<b>Input</b> .....	<b>4</b>
4.1	Operation.....	4
4.2	Input Power LED .....	4
4.3	PSE Detect.....	4
<b>5</b>	<b>Output</b> .....	<b>5</b>
5.1	Output Power LED .....	5
5.2	Output Voltage Adjust .....	5
5.1	Data Output .....	5
<b>6</b>	<b>EMI</b> .....	<b>5</b>
<b>7</b>	<b>Test Setup</b> .....	<b>6</b>
<b>8</b>	<b>Additional information</b> .....	<b>6</b>
<b>9</b>	<b>Schematic</b> .....	<b>7</b>
<b>10</b>	<b>Bill of Materials</b> .....	<b>8</b>
<b>11</b>	<b>Layer Routing</b> .....	<b>9</b>

## Table of Figures

Figure 1:	EvalAg7010 Board Layout.....	3
Figure 2:	Basic Test Setup .....	6
Figure 3:	Schematic.....	7
Figure 4:	Bill of Materials .....	8
Figure 5:	Top Layer Routing.....	9
Figure 6:	Bottom Layer Routing.....	9

## 1 Kit Contents

- EvalAg5700 Evaluation Board
- Ag57xxLPB Module Soldered to Evaluation Board

## 2 Board Layout

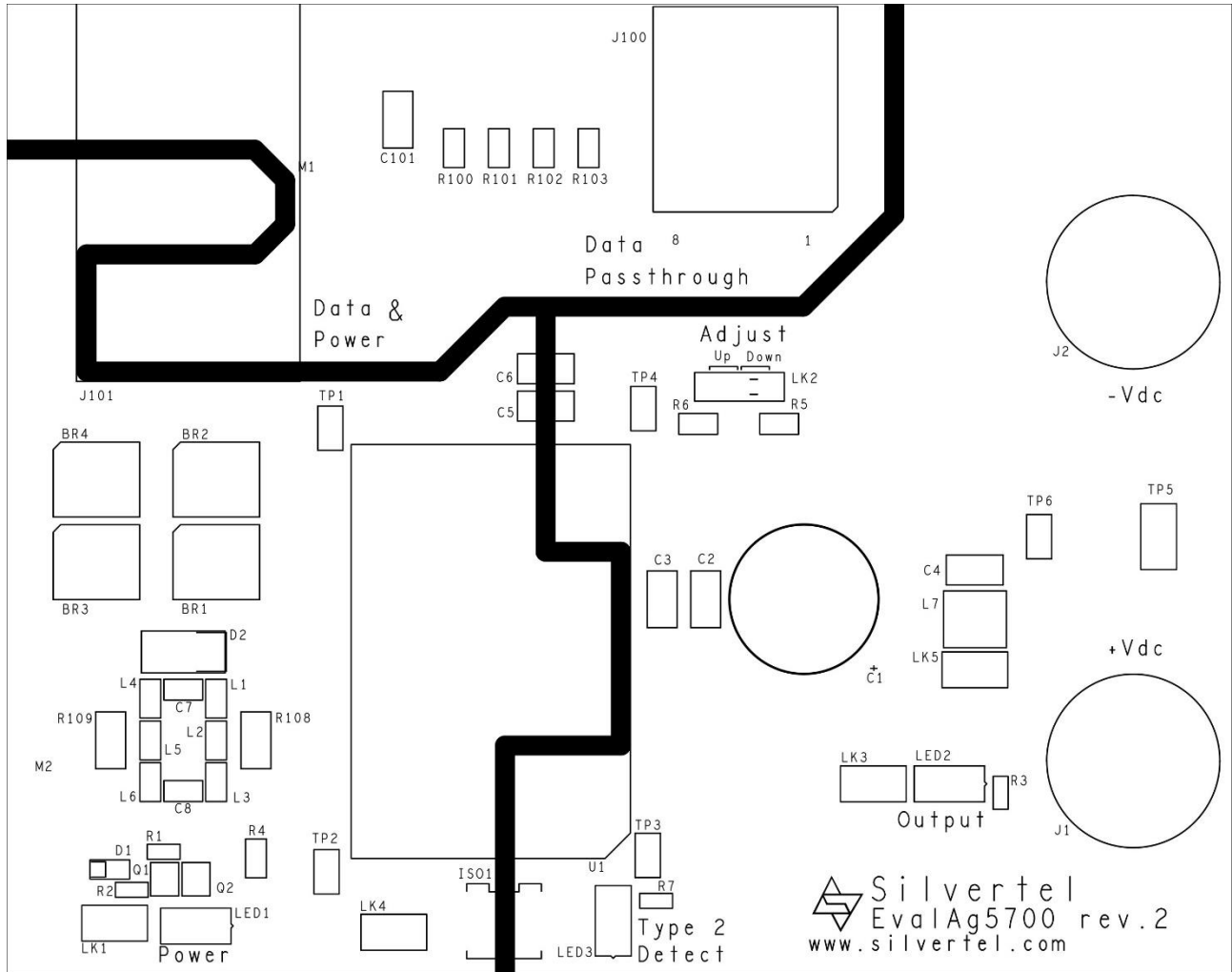

Figure 1: EvalAg7010 Board Layout

### 2.1 Link Settings

- LK1 – Input Power LED Enable
- LK2 – Output voltage Adjust
- LK3 – Output Power LED Enable
- LK4 – Type 2 Detect LED Enable

### 2.2 Input Output Connections

- J1 & J2 – Load Output Binding Posts
- J101 – PoE Enabled RJ45
- J100 – Data Passthrough RJ45



# Evaluation Board User Manual

## 3 Introduction

This Manual is a guide to using the EvalAg5700 evaluation board fitted with a Silvertel Ag5712LPB or Ag5724LPB miniaturised Class 4 surface mount power over ethernet module.

This board has been designed to assist with evaluating the use of Silvertel's module in an application; as such it has been designed to pass through Ethernet data signals (10/100/1000BASE-T) from the Midspan PSE (Power Sourcing Equipment) or PoE enabled switch connected to J101, onto the system connected to J100.

While this evaluation board has been designed following Silvertel's recommendations, it should not be considered as a reference design as it features circuitry included solely for the purposes of evaluation that are not be required for proper operation.

## 4 Input

The EvalAg5700 board will extract the power from the data pairsets using the RJ45 connector with integrated magnetics, J101. The data is passively passed on to any peripheral equipment via J100, while the power is provided to the Ag5700LPB module in the correct polarity via the bridge rectifiers BR1-BR4.

### 4.1 Operation

To ensure that the PSE does not apply power to a non-PoE enabled device the output port first checks for a valid PoE signature. If the PSE does not see a valid signature, then it will disconnect, wait approximately 2 seconds then try again.

Once a valid signature has been detected the PSE may then perform classification to determine the power requirement of the PD, only after this has occurred will the PSE supply power to the powered device.

The module will provide the 25K signature followed by a class 4 power level request to be powered by an IEEE compliant PSE.

If PSE is not capable of supplying the Class four power level requested by the Ag5700LPB, if using an IEEE802.3af PSE for example, it should supply the highest power level it is capable of supplying.

### 4.2 Input Power LED

LED1 illuminates when the module is being supplied with greater than 36V. This can be disabled by removing the jumper link LK1, removing this link does not affect the power being delivered to the Ag5700LPB.

### 4.3 PSE Detect

When the Ag5700LPB module fitted has detected it is being powered by an IEEE802.3 type 2 or greater PSE, the 'TYP2-DET' pin will be pulled low, and this will cause LED3 to become illuminated on the EvalAg5700 board.

## 5 Output

The Ag5700LPB output voltage will be present on the two binding post terminations J1 and J2. These can be connected to with 4mm Banana connectors, bare wire, or fork connectors.

### 5.1 Output Power LED

LED2 illuminates when the module is outputting. This can be disabled by removing the jumper link LK3, removing this link does not affect the power being supplied by the Ag5700LPB.

### 5.2 Output Voltage Adjust

The output voltage of the Ag5700LPB module can be adjusted by changing the location of the jumper LK2. The EvalAg5700 is fitted with two adjust resistors. The down adjust resistor R5, is fitted with a 68k $\Omega$  resistor. And the up adjust resistor R6, which is fitted with a 0 $\Omega$  resistor to allow for the maximum adjust change of the Ag5700LPB module.

To increase the output voltage, insert the jumper to LK2 in the left position, so that the link is between the middle and leftmost pin.

To reduce the output voltage, insert a jumper to LK2 in the right position, so that the link is between the middle and rightmost pin.

If the output voltage needs to be set to a different value (within the adjustment range) then connect different value resistors in place of R5 (68K) or R6 (0 $\Omega$ ) and connect the jumper into the corresponding link setting.

Note: ensure that the down adjust resistor is not shorted when connecting a module that has a higher stated resistance in the datasheet, as this could cause damage to the module.

### 5.1 Data Output

Any data that is provided over the PI (Ethernet cable) connected to the Data & Power port, J100 will be transposed onto the Data output port, J101 via the data transformer.

The data traces on the evaluation board have been designed to pass through 10/100/1000BASE-T Ethernet data signals. No processing or amplification of this signal will be performed on the evaluation board.

## 6 EMI

The EvalAg5700 contains the recommended components for EMI filtering, see ANX-POE-EMI for more details.

The board is fitted with ferrite beads, L1-6; if these are not required, they can be effectively removed from the circuit by fitting R108 and R109 with 0 $\Omega$  resistors.

## 7 Test Setup

Figure 2 shows the basic set up using the EvalAg5700 evaluation board powered by Silvertel's EvalAg6120 PSE.

The equipment required: -

- EvalAg5700 fitted with Silvertel's Ag5712LPB or Ag5724LPB PD Module.
- EvalAg6120 or other IEEE802.3 compliant PSE
- Power supply unit, +50-57V output e.g. 60V bench power supply
- CAT5e or greater cables
- Application Circuit

Optional equipment: -

Data source e.g. PC

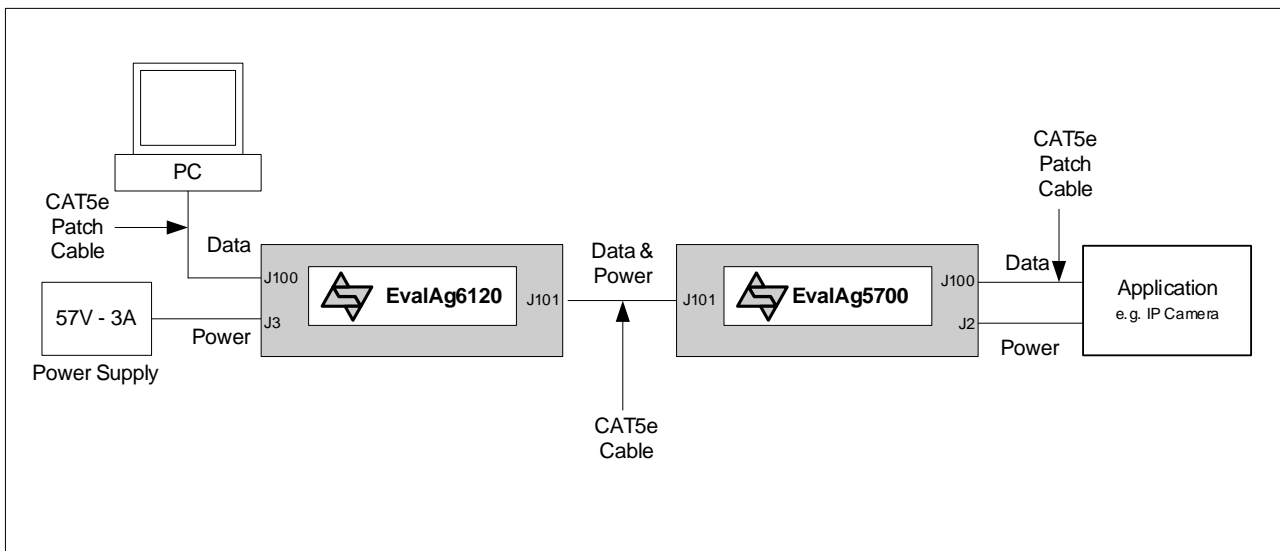

**Figure 2: Basic Test Setup**

## 8 Additional information

Full operating conditions and feature set can be found in the Ag5700 product datasheet, available from [www.silvertel.com](http://www.silvertel.com).

### 9 Schematic

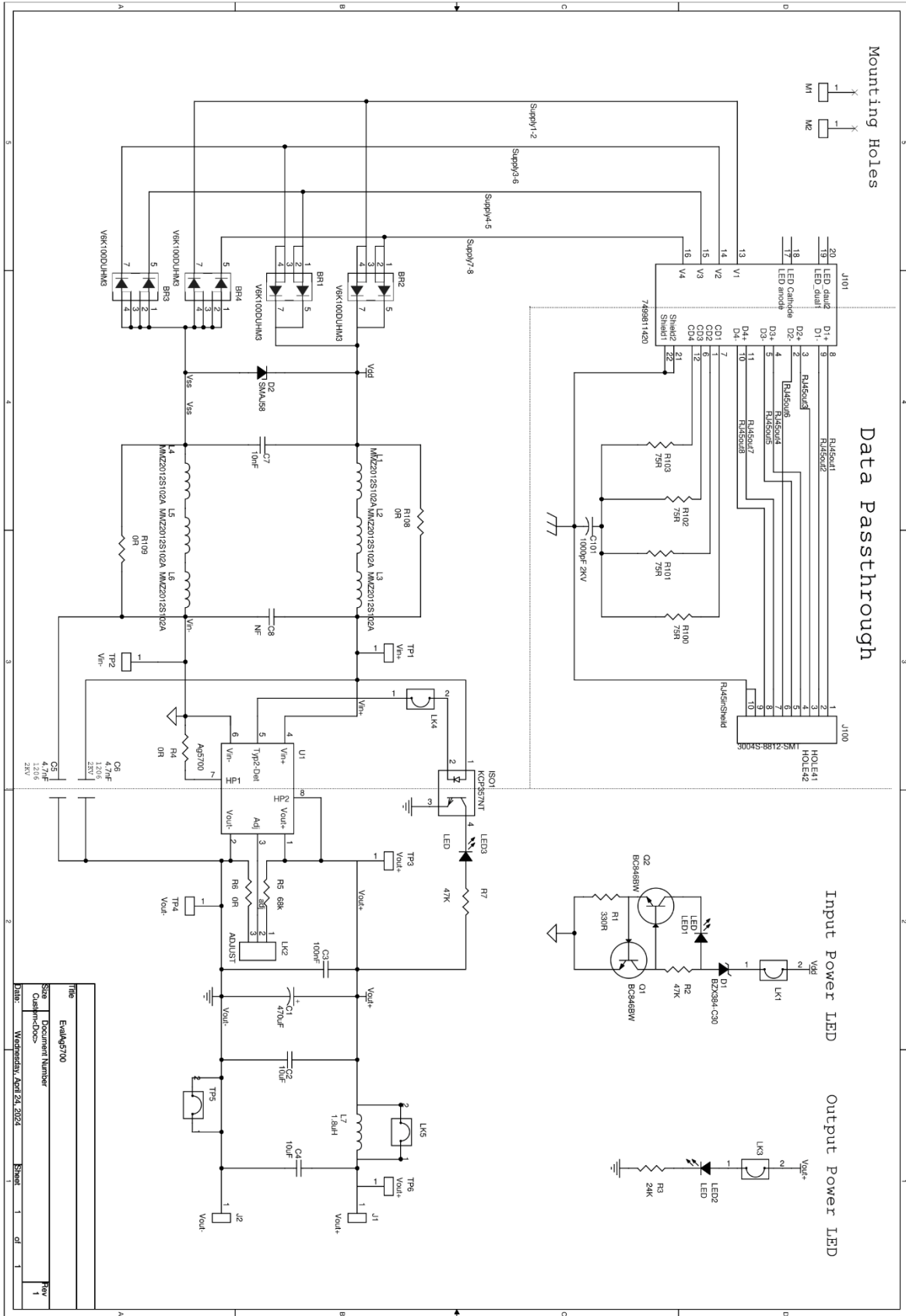

Figure 3: Schematic

### 10 Bill of Materials

Silver Part No.	Description	Value	Location:	Qty.	Package:	Rating:	Tol:	Supplier Pt. NO.	Comments:
	PD Module	Ag5700	U1	1	Custom	-	-	Silver Telecom Part	
	Zener Diode	BZX384-C30	D1	1	SOD323	-	-	Vishay	
	Protection Diode	SMAJ56A	D2	1	SMA	-	-	Wurth - 824 500 581, Vishay, ST Micro, Diodes Inc	
	Bridge Rectifiers	V6K1000JHM3	BR1-BR4	4	FlatPAK -5x6	-	-	Vishay	
	SMD LED	RED LED	LED1-LED3	3	SMT	-	-	Wurth - 150 141 RS7 310 0	
	Ferrite Chip	≥10000@100MHz	L1-6	6	0805	≥ 1A	25%	TDK MP22012S102A, Wurth 742792096	
	Inductor	1.8uH	L7	1	SMD	3A	20%	NP43C1R8MTRF/OWI0403-1R8M-R-T1-LFWurth-74438356018	
	NPN Transistor	BC846BW	Q1, Q2	2	SOT323	60V	-	Infrason, ON-Semi, NXP, Diodes Inc.	
	Opto-Isolator	140356145200 , KPC357NT	ISO1	1	SMT	-	-	Wurth, Cosmo Electronics Corp	
	Capacitor Electrolytic	470uF	C1	1	Through Hole	25V	20%	Kemet A750MS477MEAAE015, Wurth 860040475008	
	Ceramic multi-layer	10uF	C2 C4	2	1206	25V	20%	TDK Murata, Kemet, Multicomp, Wurth 885012208069	
	Ceramic multi-layer	1000nF	C3	1	1206	25V	20%	TDK, Murata, Kemet, Multicomp, Wurth 885012208068	
	Ceramic multi-layer	4.7nF	C5, C6	2	1206	1kV	20%	TDK, Murata, Kemet, Multicomp, Wurth 885342208020	
	Ceramic multi-layer	No Fil	C7, C8	0	0805	100V	20%		
	Ceramic multi-layer	1000pF 2kV	C108	1	1206	2kV	20%	Samsung, NTC, TDK, Murata, Kemet & AVX, Wurth-885342208024	
	Resistor - 0603	330R	R1	1	0603	63mW	1%	Royal Ohm, Eurohm & Yageo	
	Resistor - 0603	47k	R2, R7	2	0603	63mW	1%	Royal Ohm, Eurohm & Yageo	
	Resistor - 0603	24k	R3	1	0603	63mW	1%	Royal Ohm, Eurohm & Yageo	
	Resistor - 0805	0R	R4, R6	2	0805	63mW	1%	Royal Ohm, Eurohm & Yageo	
	Resistor - 0805	68k	R5	1	0805	63mW	1%	Royal Ohm, Eurohm & Yageo	
	Resistor - 0805	75R	R100-103	4	0805	125mW	1%	Royal Ohm, Eurohm & Yageo	
	Resistor - 1206	0R	R108, R109	0	1206	250mW	1%	Royal Ohm, Eurohm & Yageo	
	Red Connector	Binding Post	J3	1	Screw Mount	-	-	Switch Electronics 354147	
	Black Connector	Binding Post	J4	1	Screw Mount	-	-	Switch Electronics 354146	
	Test Point	HK-1-G	TP1-4, TP6	5	SMT	-	-	Mac 8	
	Ethernet Connector	RJ45	J100	1	SMT	-	-	Toby, 3004S, 8821-SMT	
	Ethernet Connector With Magnetics	7499811420	J101	1	SMT	-	-	Wurth - 7499811420	
	Link	2Way	LK1, LK3-5, TP5	5	Through Hole	-	-	Toby, LHCS-02S-R-060-034, Wurth 61300211121	
	Link	3 Way	LK3	1	Through Hole	-	-	Toby, LHCS-02S-R-060-034, Wurth 61300311121	
	PCB	Rev.2.0 - 104, 14mm x 82,55mmmm		1					
	Jumper Links	Links	LK1-5,	5					
			Total	59					

EvalAg5700 Eval Board - Rev.2

Date: 5th February, 2024

Figure 4: Bill of Materials



## 11 Layer Routing

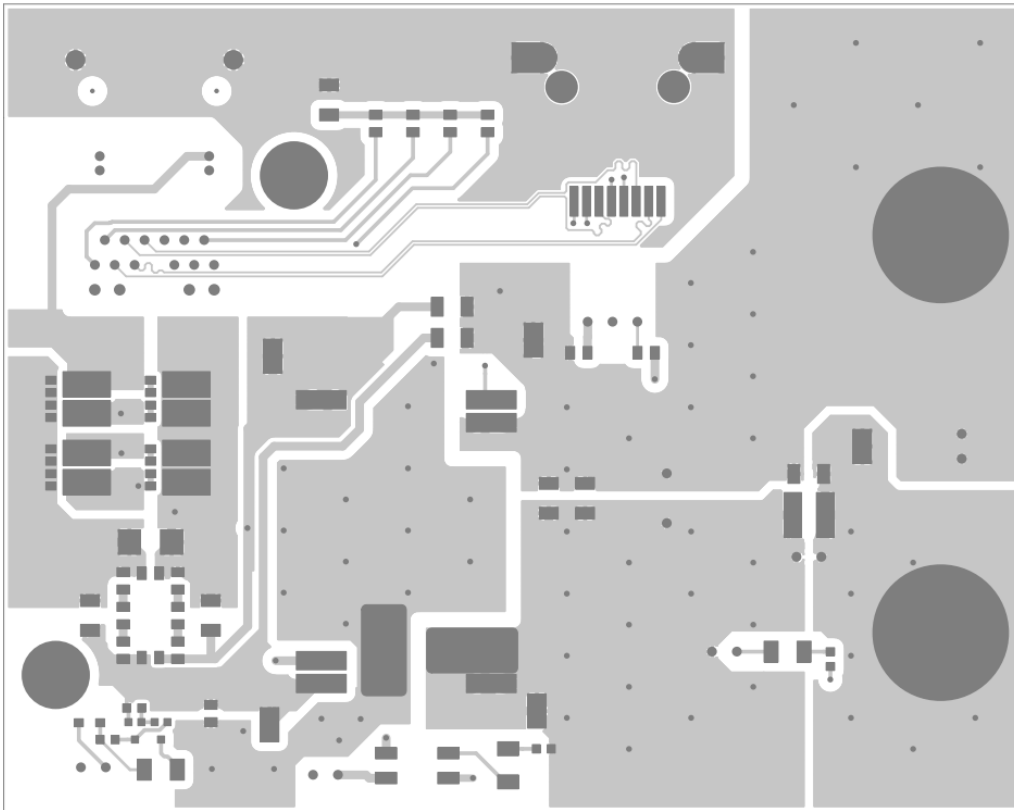

**Figure 5: Top Layer Routing**

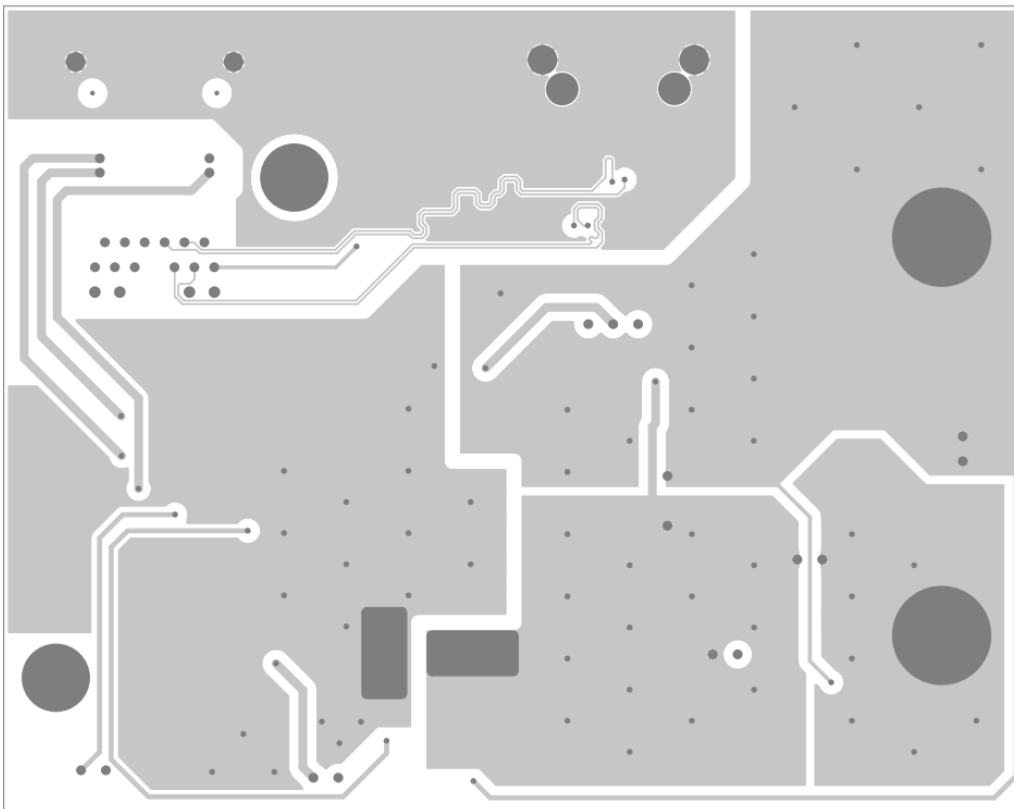

**Figure 6: Bottom Layer Routing**

## X-ON Electronics

Largest Supplier of Electrical and Electronic Components

*Click to view similar products for [Ethernet Development Tools](#) category:*

*Click to view products by [Silvertel](#) manufacturer:*

Other Similar products are found below :

[KSZ8081RNB-EVAL](#) [EV06P90A](#) [GSW145-EVK-1](#) [GPY215-EVK-1](#) [EVB9512](#) [KSZ8041NL-EVAL](#) [KSZ8851SNL-EVAL](#) [KSZ8999-EVAL](#)  
[WIZ550S2E-232-EVB](#) [EVB-MEC1428MECC](#) [MIKROE-2796](#) [3201](#) [KIT-14547](#) [OM14500/TJA1102JP](#) [DFR0125](#) [UKIT-006GP](#) [UKIT-](#)  
[003FE](#) [UKIT-002GB](#) [UKIT-001FE](#) [EVB-KSZ9477](#) [OM-E-ETH](#) [3785](#) [A000024](#) [ASX00006](#) [ASX00021](#) [ASX00026](#) [PE-405](#) [G650-07975-01](#)  
[76002138](#) [XKRR-Z8S-WZM](#) [EK-1700-21N3](#) [EK-1700-22M3](#) [EK-5700-2L](#) [ESP32-ETHERNET-KIT-VE](#) [EVB-KSZ9897-1](#) [SGMII-PEX-](#)  
[RISER](#) [KITA2GTC377SECGTWTBO1](#) [MICRO125-KIT](#) [U138](#) [MXL86110I-EVK-1](#) [KSZ9031RNX-EVAL](#) [AC164121](#) [AC164123](#)  
[AC164132](#) [AC320004-5](#) [AC320004-6](#) [AC320004-7](#) [DM320114](#) [DM990004](#) [EV02N47A](#)