

SDM017G10DB

100V SGT N-Channel MOSFETs

Rev B.0

Feature

- ✧ Low Gate Charge
- ✧ High current Capability
- ✧ Enhanced body diode performance.
- ✧ Green product (Rohs compliant), lead free
- ✧ 100% UIS Tested, 100% Rg Tested
- ✧ AEC-Q101 qualified

Product Summary

V_{DS}	100	V
$V_{GS(th_Typ)}$	1.9	V
$R_{DS(ON_Typ)}$ (at $V_{GS} = 10V$)	14	m Ω
I_D (at $V_{GS} = 10V$) ⁽¹⁾	40	A

Type	Package	Marking	Outline	Media	Quantity (pcs)
SDM017G10DB	TO-252	M017G10B	Tape	13" Reel	2500

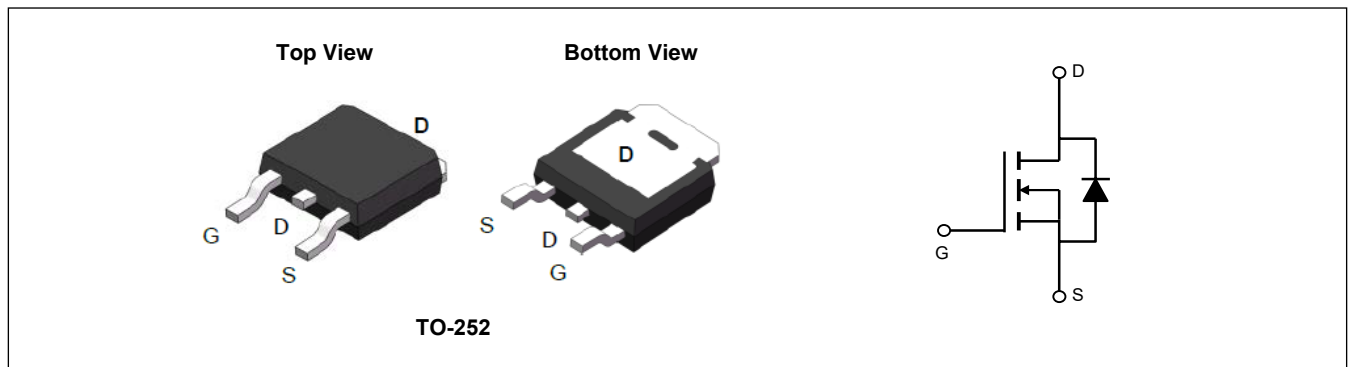

Absolute Maximum Ratings (Rating at $T_A=25^\circ C$ unless otherwise noted)

Parameter	Symbol	Maximum	Unit
Drain-Source Voltage	V_{DS}	100	V
Gate-Source Voltage	V_{GS}	± 20	V
Continuous Drain Current ⁽¹⁾	I_D	$T_C=25^\circ C$	40
		$T_C=100^\circ C$	25
Pulsed Drain Current ⁽²⁾	I_{DM}	116	A
Avalanche Current ⁽³⁾	I_{AS}	22	A
Avalanche Energy ⁽³⁾	E_{AS}	24	mJ
Power Dissipation ⁽⁴⁾	P_D	$T_C=25^\circ C$	52
		$T_C=100^\circ C$	21
Junction and Storage Temperature Range	T_J, T_{STG}	-55 to +150	$^\circ C$

Electrical Characteristics (Rating at $T_J=25^\circ\text{C}$ unless otherwise noted)

Symbol	Parameter	Conditions	Min	Typ	Max	Unit
STATIC PARAMETERS						
BV_{DSS}	Drain-Source Breakdown Voltage	$I_D=250\mu\text{A}$, $V_{GS}=0\text{V}$	100	-	-	V
I_{DSS}	Zero Gate Voltage Drain Current	$V_{DS}=80\text{V}$, $V_{GS}=0\text{V}$	-	-	1	μA
		$T_J=55^\circ\text{C}$	-	-	5	
I_{GSS}	Gate-Body Leakage Current	$V_{DS}=0\text{V}$, $V_{GS}=\pm 20\text{V}$	-	-	± 100	nA
$V_{GS(th)}$	Gate Threshold Voltage	$V_{DS}=V_{GS}$, $I_D=250\mu\text{A}$	1.2	1.9	2.5	V
$R_{DS(on)}$	Static Drain-Source On-Resistance	$V_{GS}=10\text{V}$, $I_D=10\text{A}$	-	14	17	m Ω
		$V_{GS}=4.5\text{V}$, $I_D=6\text{A}$	-	18.5	23	
g_{FS}	Forward Transconductance	$V_{DS}=5\text{V}$, $I_D=20\text{A}$	-	48	-	S
V_{SD}	Diode Forward Voltage	$I_S=1\text{A}$, $V_{GS}=0\text{V}$	-	0.7	1.0	V
I_S	Maximum Body-Diode Continuous Current		-	-	52	A
DYNAMIC PARAMETERS ⁽⁵⁾						
C_{iss}	Input Capacitance	$V_{GS}=0\text{V}$, $V_{DS}=50\text{V}$, $f=1\text{MHz}$	-	769	-	pF
C_{oss}	Output Capacitance		-	171	-	pF
C_{rss}	Reverse Transfer Capacitance		-	5.1	-	pF
R_g	Gate Resistance	$V_{GS}=0\text{V}$, $V_{DS}=0\text{V}$, $f=1\text{MHz}$	-	1.9	-	Ω
SWITCHING PARAMETERS ⁽⁵⁾						
$Q_g(10\text{V})$	Total Gate Charge	$V_{GS}=0\sim 10\text{V}$, $V_{DS}=50\text{V}$, $I_D=10\text{A}$	-	12.7	-	nC
$Q_g(6.0\text{V})$	Total Gate Charge		-	6.7	-	nC
Q_{gs}	Gate Source Charge		-	2.1	-	nC
Q_{gd}	Gate Drain Charge		-	3.3	-	nC
$t_{D(on)}$	Turn-On Delay Time	$V_{GS}=10\text{V}$, $V_{DS}=50\text{V}$, $R_L=2.5\Omega$, $R_{GEN}=6.0\Omega$	-	4.3	-	ns
t_r	Turn-On Rise Time		-	5.1	-	ns
$t_{D(off)}$	Turn-Off Delay Time		-	16.7	-	ns
t_f	Turn-Off Fall Time		-	8.7	-	ns
t_{rr}	Body Diode Reverse Recovery Time	$I_F=15\text{A}$, $di/dt=100\text{A}/\mu\text{s}$	-	39	-	ns
Q_{rr}	Body Diode Reverse Recovery Charge	$I_F=15\text{A}$, $di/dt=100\text{A}/\mu\text{s}$	-	30	-	nC

Thermal Resistances

Symbol	Parameter	Typ	Max	Unit
$R_{\theta JC}$	Thermal resistance from junction to case	1.8	2.4	$^{\circ}\text{C} / \text{W}$
$R_{\theta JA}$	Thermal resistance from junction to ambient	42	50	$^{\circ}\text{C} / \text{W}$

Notes:

1. Computed continuous current assumes the condition of T_{J_Max} while the actual continuous depends on the thermal & electro-mechanical application board design.
2. This single-pulse measurement was taken under $T_{J_Max}=150^{\circ}\text{C}$.
3. This single-pulse measurement was taken under the following condition [$L=100\mu\text{H}$, $V_{GS}=10\text{V}$, $V_{DS}=50\text{V}$] while its value is limited by $T_{J_Max}=150^{\circ}\text{C}$.
4. The power dissipation P_D is based on $T_{J_Max}=150^{\circ}\text{C}$.
5. This value is guaranteed by design hence it is not included in the production test.

Typical Electrical and Thermal Characteristics

Figure 1: Saturation Characteristics

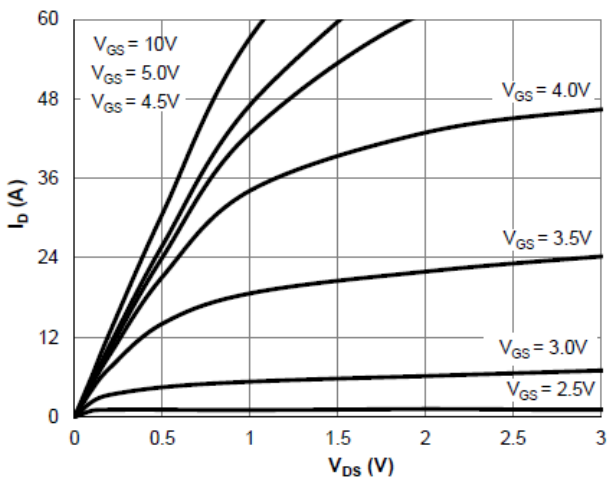

Figure 2: Transfer Characteristics

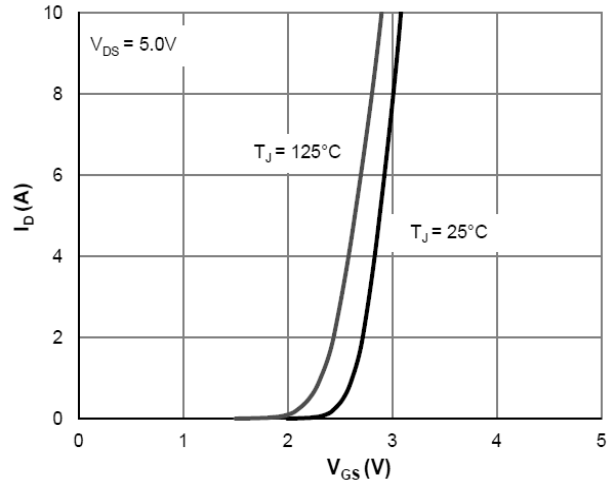

Figure 3: $R_{DS(ON)}$ vs. Drain Current

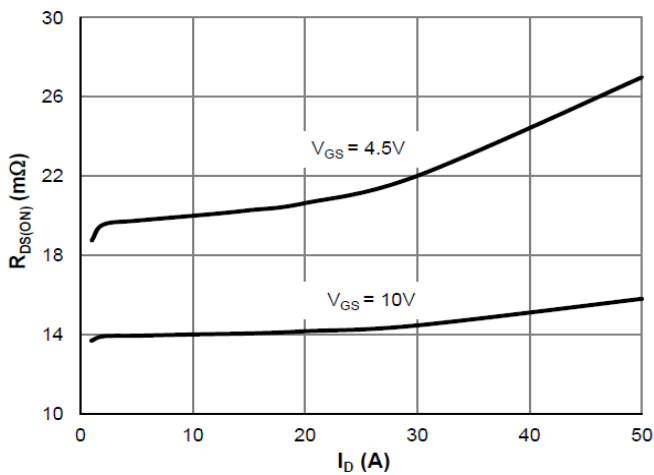

Figure 4: $R_{DS(ON)}$ vs. Junction Temperature

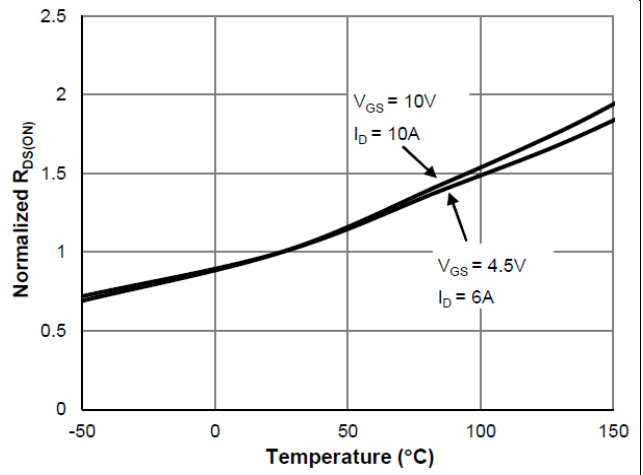

Figure 5: Body-Diode Characteristics

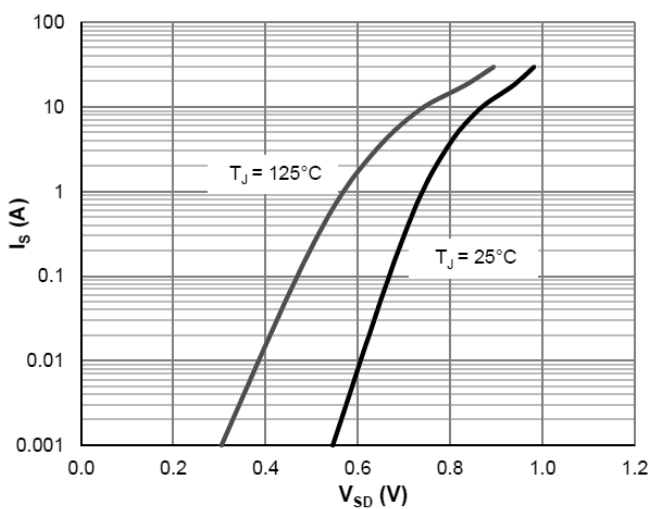
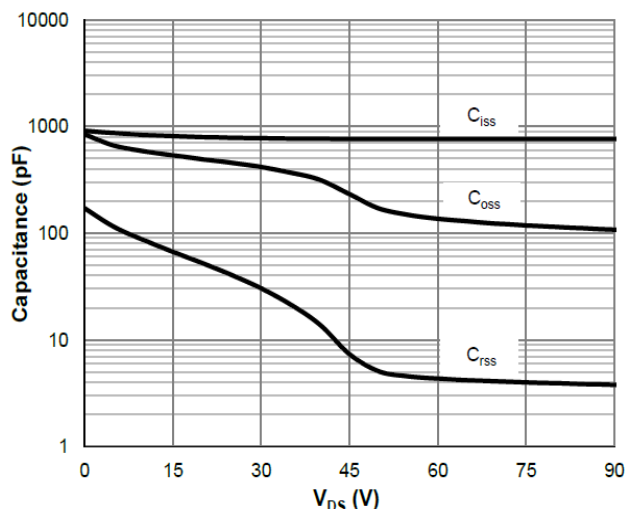

Figure 6: Capacitance characteristics



Typical Electrical and Thermal Characteristics

Figure 7: Current De-rating **Figure 8: Power De-rating**

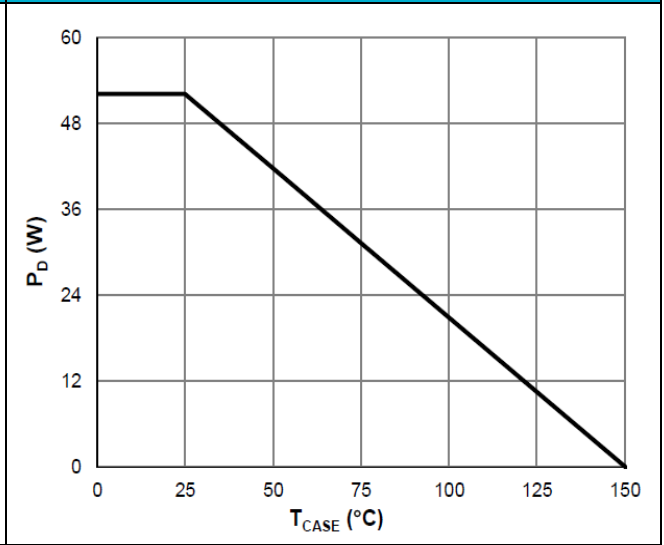
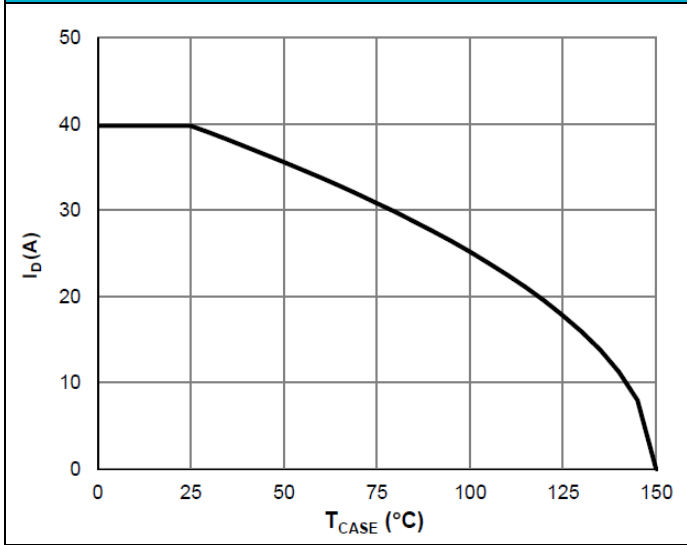

Figure 9: Maximum Safe Operating Area

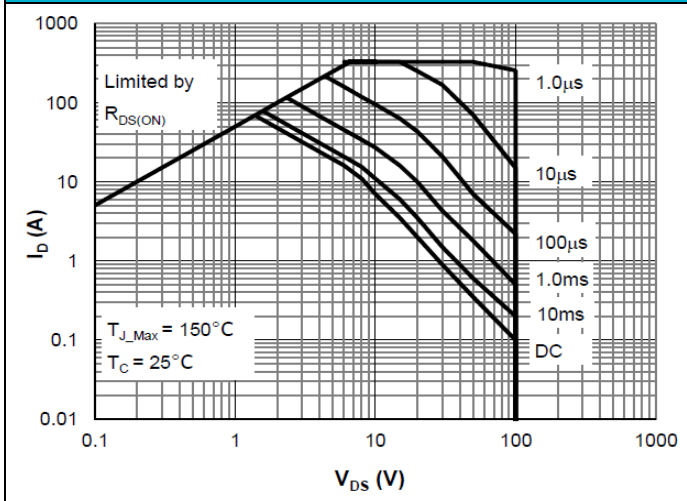

Figure 10: Single Pulse Power Rating, Junction-to-Case

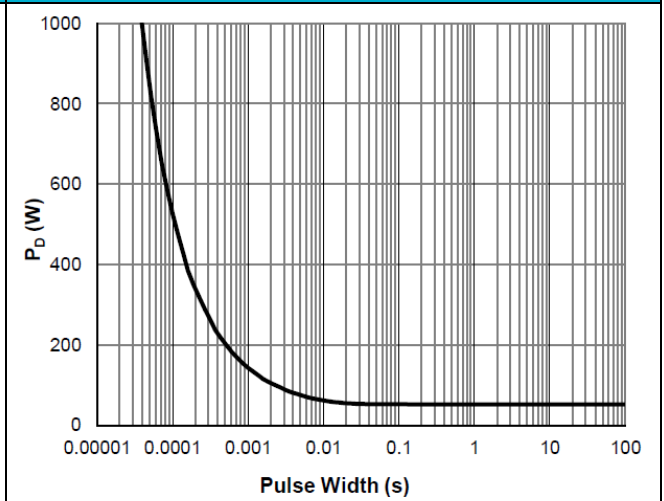
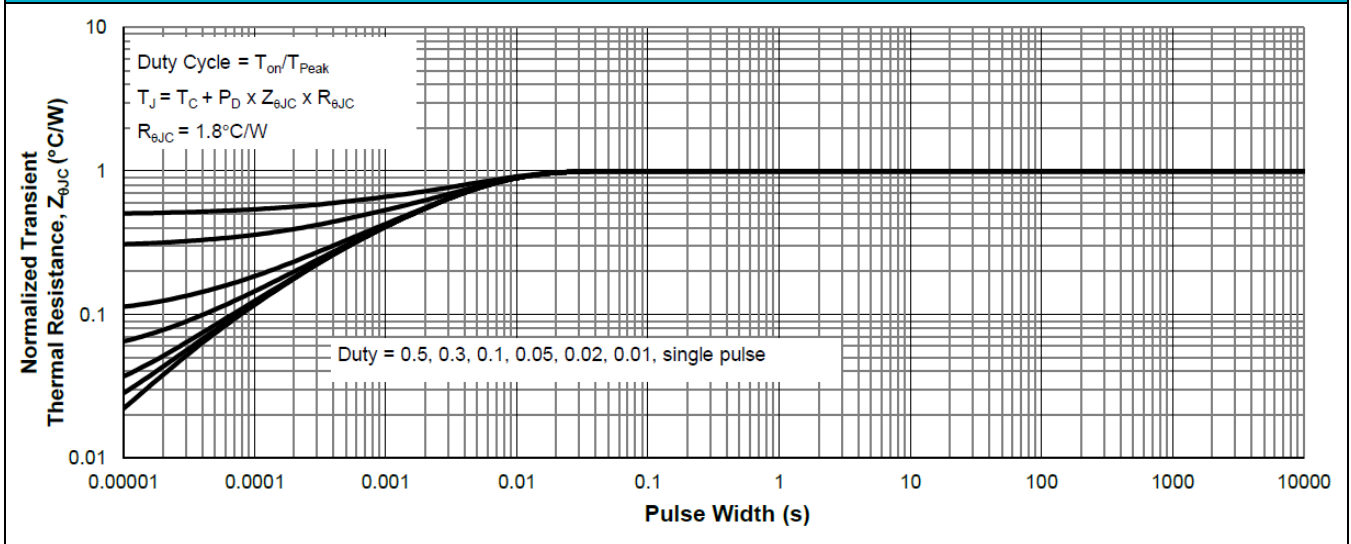

Figure 11: Normalized Maximum Transient Thermal Impedance



Test Circuit

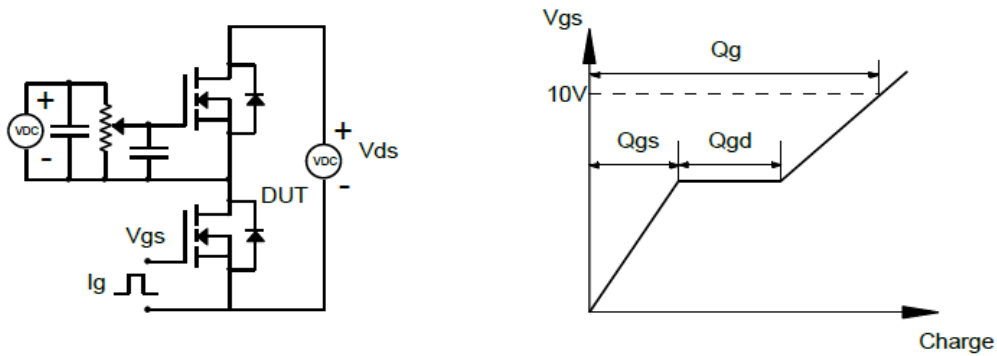

Figure1: Gate Charge Test Circuit & Waveforms

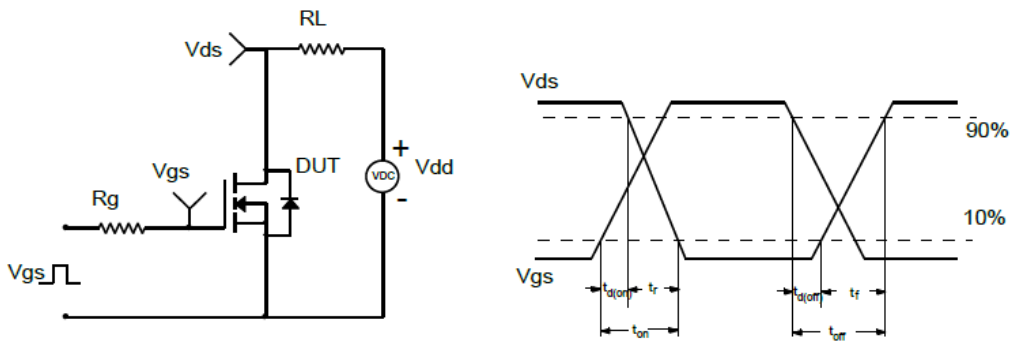

Figure2: Resistive Switching Test Circuit & Waveforms

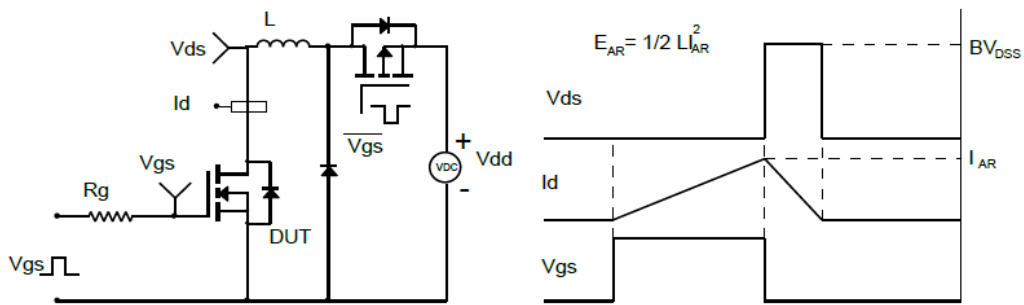

Figure3: Unclamped Inductive Switching (UIS) Test Circuit & Waveforms

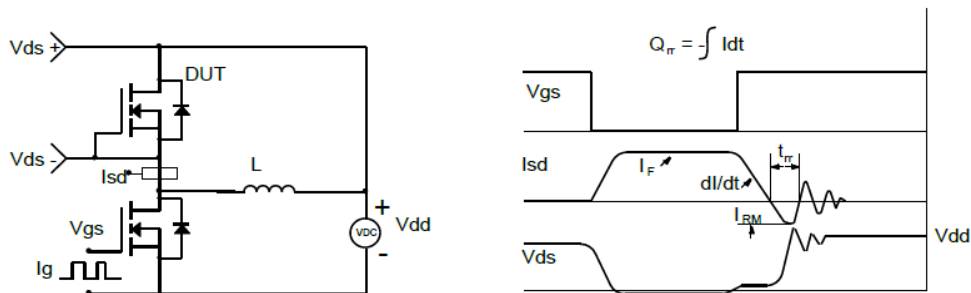
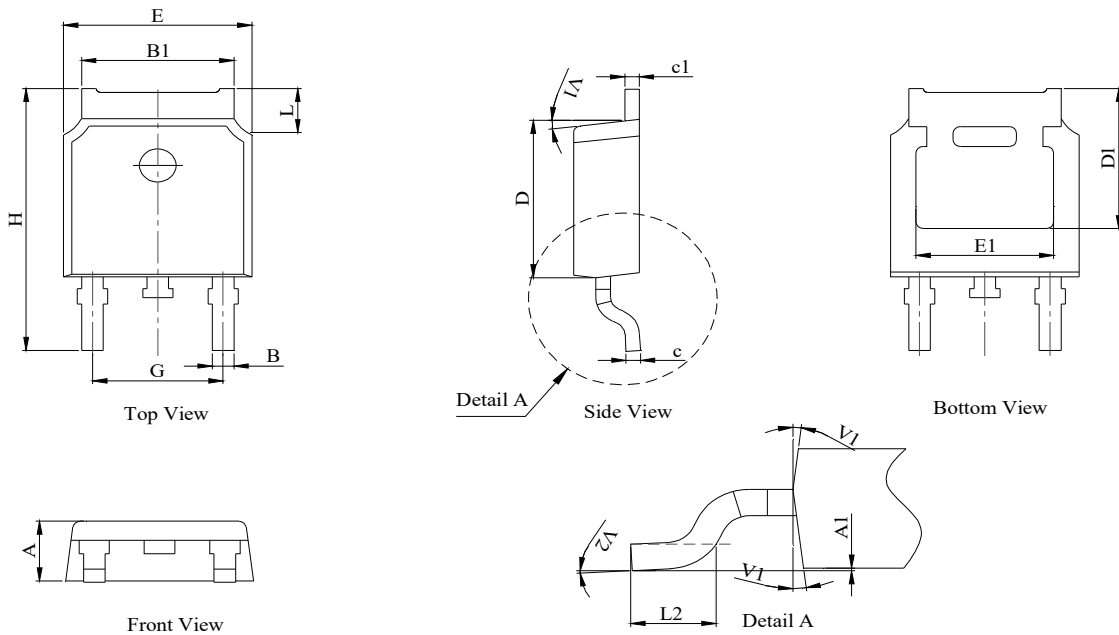

Figure4: Diode Recovery Test Circuit & Waveforms

TO-252 Package Information

Package Outline



DIM.	MILLIMETER		
	MIN.	NOM.	MAX.
A	2.10		2.50
A1	0	-	0.10
B	0.66		0.86
B1	5.18		5.48
c	0.40		0.60
c1	0.44		0.58
D	5.90		6.30
D1	5.30REF		
E	6.40		6.80
E1	4.63		
G	4.47		4.67
H	9.50		10.70
L	1.09		1.21
L2	1.35		1.65
V1		7°	
V2	0°	-	6°

Recommend Footprint

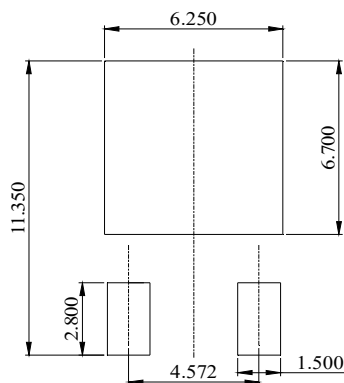

DIMENSIONS: MILLIMETERS

X-ON Electronics

Largest Supplier of Electrical and Electronic Components

Click to view similar products for [MOSFET](#) category:

Click to view products by [SINEDEVICE](#) manufacturer:

Other Similar products are found below :

[IRFD120](#) [IRFY240C](#) [JANTX2N5237](#) [2SK2267\(Q\)](#) [BUK455-60A/B](#) [MIC4420CM-TR](#) [VN1206L](#) [NDP4060](#) [SI4482DY](#)
[IPS70R2K0CEAKMA1](#) [SQD23N06-31L-GE3](#) [TK16J60W,S1VQ\(O](#) [2SK2614\(TE16L1,Q\)](#) [DMN1017UCP3-7](#) [EFC2J004NUZTDG](#)
[DMN1053UCP4-7](#) [SQJ469EP-T1-GE3](#) [NTE2384](#) [DMC2700UDMQ-7](#) [DMN2080UCB4-7](#) [DMN61D9UWQ-13](#) [US6M2GTR](#)
[DMN31D5UDJ-7](#) [DMP22D4UFO-7B](#) [DMN1006UCA6-7](#) [DMN16M9UCA6-7](#) [STF5N65M6](#) [IRF40H233XTMA1](#) [STU5N65M6](#)
[DMN6022SSD-13](#) [DMN13M9UCA6-7](#) [DMTH10H4M6SPS-13](#) [DMN2990UFB-7B](#) [IPB80P04P405ATMA2](#) [2N7002W-G](#) [MCAC30N06Y-](#)
[TP](#) [MCQ7328-TP](#) [NTMC083NP10M5L](#) [NVMFS2D3P04M8LT1G](#) [BXP7N65D](#) [BXP4N65F](#) [AOL1454G](#) [WMJ80N60C4](#) [BXP2N20L](#)
[BXP2N65D](#) [BXT1150N10J](#) [BXT1700P06M](#) [TSM60NB380CP](#) [ROG](#) [RQ7L055BGTCR](#) [DMNH15H110SK3-13](#)