

重要提醒 (下列条件适用于 SMD 产品系列内的所有零件):

- 请参照技术手册中的建议设计电路板。
- 必须根据回流焊/波峰焊技术规范选择合格的焊料，严格控制焊接温度、时间。
- 焊接工艺会导致产品表面变色。
- 爬锡现象会导致内孔堵塞，因此通孔产品不适用波峰焊，建议采用回流焊。
- 所有产品应在出厂 12 个月内使用，超出有效期会影响可焊性。
- 必须在密封、干燥环境下保存。
- 零件与 PCB 的连接强度由产品、焊盘、焊接效果等因素综合决定
- 必须控制最大锁附扭力，防止元件和 PCB 受到机械破坏。
- 工作电流由 PCB、电缆接头、电缆横截面等因素综合决定。
- 手册中如有标注参考电流，零件使用材料为黄铜 **C3604(H59)**



Cautions and Warnings:

The following conditions apply to all goods within the product series of Sinhoo PCB SMD

General:

All recommendations according to the general technical specifications of the data-sheet have to be complied with.

The responsibility for the applicability of customer specific products and use in a particular customer design is always within the authority of the customer. All technical specifications for standard products do also apply for customer specific products.

Product Specific:

Follow all instructions in the datasheet, especially:

- The solder profile has to be complied with according to the technical reflow soldering specification, otherwise no warranty will be sustained.
- Surface discoloration due to reflow processing is permitted.
- Wave soldering is not applicable. Reflow soldering is recommended.
- All products shall be used before the end of the period of 12 months based on the product date-code, if not a 100% solderability can't be ensured.
- The maximum permissible torques must be complied with to prevent mechanical destruction of the elements and PCB.
- Operating current depends on PCB, cable lug and cross section of the cable.
- The connection strength between parts and PCB is determined by product, pad and welding effect
- If the operating current is marked in the manual, the material used for the parts is brass C3604(H59)

PART NUMBER DESIGNATION

SMTSO 20 25 C T J

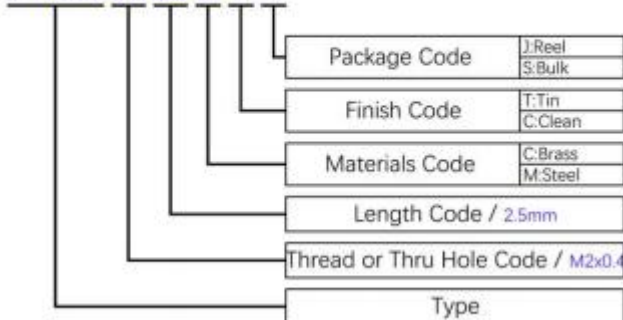

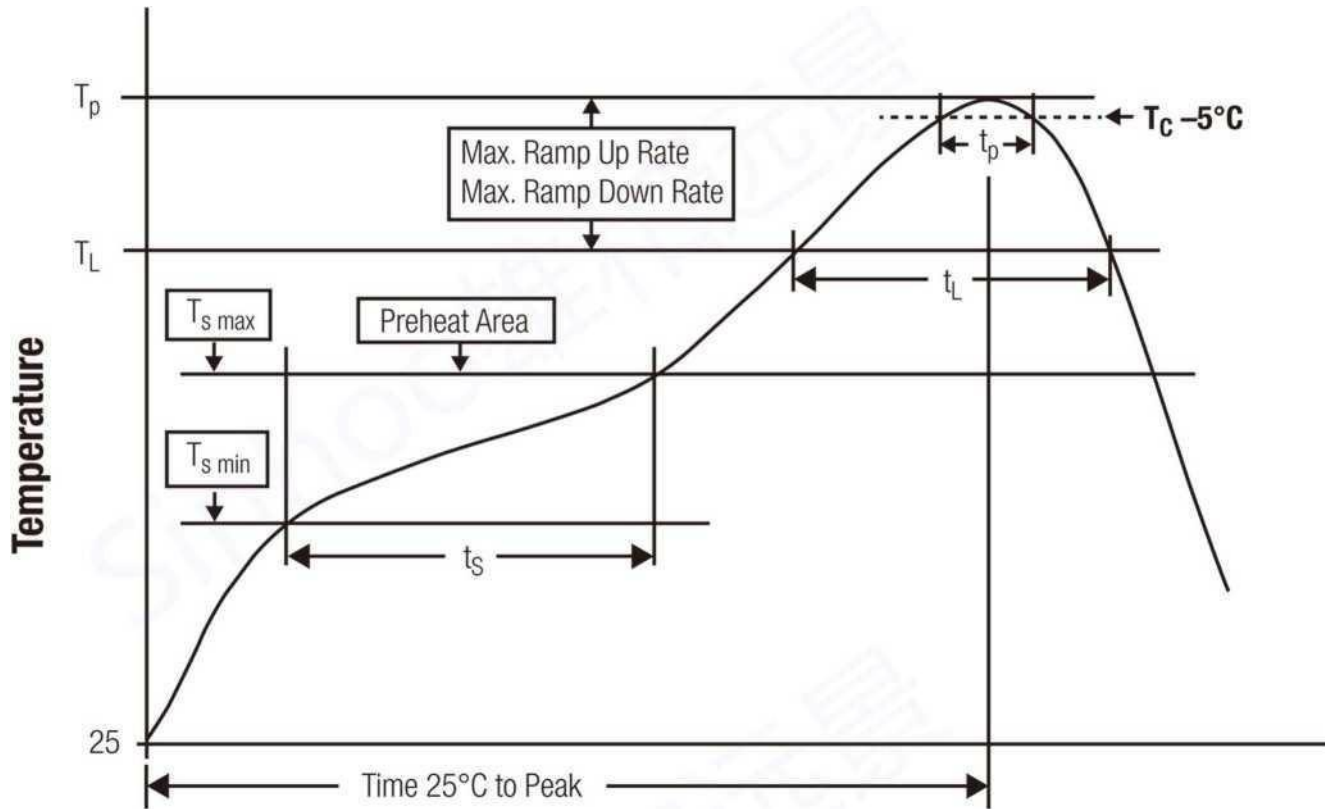

Classification Reflow Profile for SMT components:

Classification Reflow Soldering Profile:

Profile Feature		Value
Preheat Temperature Min ($T_s \text{ min}$)	L_{min}	150°C
Preheat Temperature Max ($T_s \text{ max}$)	$T_s \text{ max}$	200°C
Preheat Time t_s from $T_s \text{ min}$ to $T_s \text{ max}$	t_s	60-120 seconds
Ramp-up Rate (T_L to T_p)		$3^\circ\text{C}/\text{second max.}$
Liquidous Temperature (T_L)	T_L	217°C
Time t_L maintained above T_L	t_L	60-150 seconds
Peak package body temperature		see table
Time within 5°C of actual peak temperature	t_p	20 - 30 seconds
Ramp-down Rate (T_L to T_p)		$6^\circ\text{C}/\text{second max.}$
Time 25°C to peak temperature		8 minutes max.

Package Classification Reflow Temperature: Time

Properties	Volume mm^3 <350	Volume mm^3 350-2000	Volume mm^3 >2000
PB-Free Assembly I Package Thickness < 1.6 mm	260°C	260°C	260°C
PB-Free Assembly I Package Thickness 1.6 mm - 2.5 mm	260°C	250°C	245°C
PB-Free Assembly I Package Thickness > 2.5 mm	250°C	245°C	245°C

X-ON Electronics

Largest Supplier of Electrical and Electronic Components

Click to view similar products for [Standoffs & Spacers](#) category:

Click to view products by [Sinhoo](#) manufacturer:

Other Similar products are found below :

[588-6208-02](#) [M0513-25-N](#) [M0609-5-SS](#) [M0655-5-AL](#) [M0655-5-N](#) [M0659-4-AL](#) [M0660-4-N](#) [M0671-5-N](#) [M0671-5-SS](#) [M0725-6-N](#)
[M0731-4-N](#) [M1273-3005-AL](#) [60187](#) [60202-SP](#) [60273](#) [60335-SP](#) [60348-SP](#) [60419-SP](#) [60425-SP](#) [60473-SP](#) [60475-SP](#) [60477-SP](#) [60489-SP](#)
[60491-SP](#) [60585-SP](#) [60762-SP](#) [60763-SP](#) [60872-SP](#) [M1313-3005-N](#) [M1314-3005-AL](#) [M1314-3005-SS](#) [M1314-3506-N](#) [M1315-4007-N](#)
[M1316-3005-N](#) [M1317-3506-SS](#) [M1318-3005-SS](#) [M1320-3005-AL](#) [M1321-3005-SS](#) [M1322-4007-N](#) [M1326-3005-AL](#) [M1577-B-4007-B](#)
[M2122-2545-SS](#) [M2140-3005-N](#) [M2143-4007-N](#) [M2145-4007-N](#) [M2148-3005-N](#) [M2157-4007-N](#) [M2162-3506-SS](#) [M2162-4007-N](#) [M2162-4007-SS](#)